

# LPM-32 NATURAL GAS TO LP GAS CONVERSION KIT 80% TWO-STAGE FURNACE INSTALLATION INSTRUCTIONS



## WARNING

ONLY PERSONNEL THAT HAVE BEEN TRAINED TO INSTALL, ADJUST, SERVICE, MAINTENANCE OR REPAIR (HEREINAFTER, "SERVICE") THE EQUIPMENT SPECIFIED IN THIS MANUAL SHOULD SERVICE THE EQUIPMENT.

THIS EQUIPMENT IS NOT INTENDED FOR USE BY PERSONS (INCLUDING CHILDREN) WITH REDUCED PHYSICAL, SENSORY OR MENTAL CAPACITIES, OR LACK OF EXPERIENCE AND KNOWLEDGE, UNLESS THEY HAVE BEEN GIVEN SUPERVISION OR INSTRUCTION CONCERNING USE OF THE APPLIANCE BY A PERSON RESPONSIBLE FOR THEIR SAFETY. CHILDREN SHOULD BE SUPERVISED TO ENSURE THAT THEY DO NOT PLAY WITH THE EQUIPMENT.

THE MANUFACTURER WILL NOT BE RESPONSIBLE FOR ANY INJURY OR PROPERTY DAMAGE ARISING FROM IMPROPER SUPERVISION, SERVICE OR SERVICE PROCEDURES. IF YOU SERVICE THIS UNIT, YOU ASSUME RESPONSIBILITY FOR ANY INJURY OR PROPERTY DAMAGE WHICH MAY RESULT. IN ADDITION, IN JURISDICTIONS THAT REQUIRE ONE OR MORE LICENSES TO SERVICE THE EQUIPMENT SPECIFIED IN THIS MANUAL, ONLY LICENSED PERSONNEL SHOULD SERVICE THE EQUIPMENT. IMPROPER SUPERVISION, INSTALLATION, ADJUSTMENT, SERVICING, MAINTENANCE OR REPAIR OF THE EQUIPMENT SPECIFIED IN THIS MANUAL, OR ATTEMPTING TO INSTALL, ADJUST, SERVICE OR REPAIR THE EQUIPMENT SPECIFIED IN THIS MANUAL WITHOUT PROPER SUPERVISION OR TRAINING MAY RESULT IN PRODUCT DAMAGE, PROPERTY DAMAGE, PERSONAL INJURY OR DEATH.



## WARNING

DO NOT BYPASS SAFETY DEVICES.

## ATTENTION INSTALLING PERSONNEL

As a professional installer, you have an obligation to know the product better than the customer. This includes all safety precautions and related items.

Prior to actual installation, thoroughly familiarize yourself with this Instruction Manual. Pay special attention to all safety warnings. Often during installation or repair, it is possible to place yourself in a position which is more hazardous than when the unit is in operation.

Remember, it is your responsibility to install the product safely and to know it well enough to be able to instruct a customer in its safe use.

Safety is a matter of common sense...a matter of thinking before acting. Most dealers have a list of specific good safety practices...follow them.

The precautions listed in this Installation Manual are intended as supplemental to existing practices. However,

if there is a direct conflict between existing practices and the content of this manual, the precautions listed here take precedence.

## DESCRIPTION

This natural gas to L.P. (liquid petroleum) gas conversion kit allows White-Rodgers gas valves 36G54 (0151F00000P) and 36J54 (0151M00027) to be used on L.P. gas applications.

Use the following parts list to ensure that all parts listed below are present and in an undamaged condition. IF ANY DOUBT EXISTS ABOUT THE CONDITIONS OF ANY COMPONENT WITHIN THIS KIT, DO NOT USE THIS KIT AND CONTACT YOUR SUPPLIER FOR A NEW KIT.

## CONTENTS OF KIT

Part Number	Description	Quantity
0163F00000P	White-Rodgers LP Conversion Kit F92-1008	1
B14933151	Conversion Label	1
B4089955	Spud Orifice Assembly	1
IO-735*	Installation Instructions	1
0151K00000S	36G54/36J54 Pressure Check Kit Valve	1
20328701	Gas Pressure Switch	1
M0021305	1/2" x 1/8" Bushing	1
20328801	Two-Stage Harness	1
0259F00077	Long Single-Stage Harness	1
W18210160271045	Long Jumper Wire	1
20346001	LP Low Pressure Kit Label	1
0140F01167	Wiring Diagram	1

### Field Supplied

1	1/2" Tee
1	90 Degree Street Elbow
1	1/2" Pipe (length dependent on model and application)

With the exception of the natural gas burner orifices, all of the fasteners and other components removed to perform this conversion are to be reused. Any component found to be damaged due to this conversion must be replaced with factory authorized replacement parts before this furnace can be put into operation.



This furnace is equipped for two-stage heating operation. The gas valve manifold pressure must be set with first stage operating at 6" +/-0.3" W.C. manifold pressure and the second stage must be set at 10" +/-0.3" W.C. manifold pressure. The accuracy of these pressures must be checked as shown in steps 25 and 26 of these instructions.

The gas valve is equipped with a 3-pin polarized plug which prevents this wiring from being installed incorrectly.

	<b>CAUTION</b>
<p><b>LABEL ALL WIRE PRIOR TO DISCONNECTION WHEN SERVICING CONTROLS. WIRING ERRORS CAN CAUSE IMPROPER AND DANGEROUS OPERATION. VERIFY PROPER OPERATION AFTER SERVICING.</b></p>	

**NOTE: Do NOT use power tools for any adjustments on gas valves.**

**CONTENTS**

<b>IMPORTANT INFORMATION .....</b>	<b>2</b>
<b>WHITE-RODGERS 36G54/36J54 CONVERSION .....</b>	
<b>INSTRUCTIONS .....</b>	<b>3</b>
<b>NOX SCREEN REMOVAL .....</b>	<b>5</b>
<b>NON-CONDENSING FURNACES &amp; PACKAGE .....</b>	
<b>GAS-ELECTRIC.....</b>	<b>5</b>
<b>LP LOW PRESSURE SWITCH INSTALLATION.....</b>	<b>5</b>
<b>FURNACES USING WHITE-RODGERS 36G/36J GAS VALVE.....</b>	<b>5</b>
<b>TROUBLESHOOTING .....</b>	<b>7</b>

The following tools and supplies are required:



- 2 – Pipe wrenches, properly sized to accommodate the gas piping and connectors
- 1 – 7/16" box wrench or socket wrench
- 1 - 5/16" nut driver
- 1 – 3/16" flat blade screwdriver
- 1 – 1/4" flat blade screwdriver
- 1 – 3/16" allen wrench
- 1 – manometer to read inlet and outlet pressure of the gas valve (Minimum range: 0"-20" W.C.)
- Pipe joint compound or pipe thread tape that is approved for use with L.P. gas.
- Gas leak detection solution like a soap and water solution. Always wipe the solution from the joints when testing is completed.



	<b>WARNING</b>
<p><b>NEVER USE AN OPEN FLAME TO CHECK FOR GAS LEAKS.</b></p>	

Prior to performing this conversion, refer to the National Fuel Gas Code (NFPA 54-02) or in Canada, CAN/CSA-B149.2-05 to ensure that the installation is in compliance with those and all local codes.

**IMPORTANT INFORMATION**

	<b>WARNING</b>
<p><b>CARBON MONOXIDE (CO) CAN CAUSE SEVERE PERSONAL INJURY OR DEATH.</b></p>	

	<b>WARNING</b>
<p><b>HIGH VOLTAGE</b>  <b>DISCONNECT ALL POWER BEFORE SERVICING OR INSTALLING THIS UNIT. MULTIPLE POWER SOURCES MAY BE PRESENT. FAILURE TO DO SO MAY CAUSE PROPERTY DAMAGE, PERSONAL INJURY OR DEATH.</b></p>	
	

	<b>DANGER</b> <b>PELIGRO</b>
	
<b>CARBON MONOXIDE POISONING HAZARD</b>	
<p>Special Warning for Installation of Furnace or Air Handling Units in Enclosed Areas such as Garages, Utility Rooms or Parking Areas</p>	
<p>Carbon monoxide producing devices (such as an automobile, space heater, gas water heater, etc.) should not be operated in enclosed areas such as unventilated garages, utility rooms or parking areas because of the danger of carbon monoxide (CO) poisoning resulting from the exhaust emissions. If a furnace or air handler is installed in an enclosed area such as a garage, utility room or parking area and a carbon monoxide producing device is operated therein, there must be adequate, direct outside ventilation.</p> <p>This ventilation is necessary to avoid the danger of CO poisoning which can occur if a carbon monoxide producing device continues to operate in the enclosed area. Carbon monoxide emissions can be (re)circulated throughout the structure if the furnace or air handler is operating in any mode.</p>	
<p>CO can cause serious illness including permanent brain damage or death. <span style="float: right;">B10259-216</span></p>	
<b>RIESGO DE INTOXICACIÓN POR MONÓXIDO DE CARBONO</b>	
<p>Advertencia especial para la instalación de calentadores ó manejadoras de aire en áreas cerradas como estacionamientos ó cuartos de servicio.</p> <p>Los equipos ó aparatos que producen monóxido de carbono (tal como automóvil, calentador de gas, calentador de agua por medio de gas, etc) no deben ser operados en áreas cerradas debido al riesgo de envenenamiento por monóxido de carbono (CO) que resulta de las emisiones de gases de combustión. Si el equipo ó aparato se opera en dichas áreas, debe existir una adecuada ventilación directa al exterior. Esta ventilación es necesaria para evitar el peligro de envenenamiento por CO, que puede ocurrir si un dispositivo que produce monóxido de carbono sigue operando en el lugar cerrado. Las emisiones de monóxido de carbono pueden circular a través del aparato cuando se opera en cualquier modo.</p>	
<p>El monóxido de carbono puede causar enfermedades severas como daño cerebral permanente ó muerte. <span style="float: right;">B10259-216</span></p>	
<b>RISQUE D'EMPOISONNEMENT AU MONOXYDE DE CARBONE</b>	
<p>Avertissement special au sujet de l'installation d'appareils de chauffage ou de traitement d'air dans des endroits clos, tels les garages, les locaux d'entretien et les stationnements.</p> <p>Évitez de mettre en marche les appareils produisant du monoxyde de carbone (tels que les automobile, les appareils de chauffage autonome, etc.) dans des endroits non ventilés tels que les d'empoisonnement au monoxyde de carbone. Si vous devez faire fonctionner ces appareils dans un endroit clos, assurez-vous qu'il y ait une ventilation directe provenant de l'exterieur.</p> <p>Cette ventilation est nécessaire pour éviter le danger d'intoxication au CO pouvant survenir si un appareil produisant du monoxyde de carbone continue de fonctionner au sein de la zone confinée. Les émissions de monoxyde de carbone peuvent étre recirculés dans les endroits clos, si l'appareil de chauffage ou de traitement d'air sont en marche.</p> <p>Le monoxyde de carbone peut causer des maladies graves telles que des dommages permanents au cerveau et meme la mort. <span style="float: right;">B10259-216</span></p>	



## WARNING

THIS L.P. (LIQUID PETROLEUM) CONVERSION KIT MUST BE INSTALLED BY A QUALIFIED SERVICE PERSON OR AGENCY IN ACCORDANCE WITH THE MANUFACTURER'S INSTRUCTIONS AND ALL APPLICABLE CODES AND REQUIREMENTS OF THE AUTHORITY HAVING JURISDICTION. FAILURE TO FOLLOW THESE INSTRUCTIONS EXPLICITLY MAY CAUSE A FIRE, EXPLOSION OR THE PRODUCTION OF CARBON MONOXIDE(CO), WHICH CAN CAUSE PROPERTY DAMAGE, PERSONAL INJURY OR DEATH. THE QUALIFIED PERSON PERFORMING THIS CONVERSION ASSUMES THE RESPONSIBILITY FOR THE PROPER CONVERSION OF THE APPLIANCE.

## WHITE-RODGERS 36G54/36J54 CONVERSION INSTRUCTIONS



## WARNING

**HIGH VOLTAGE**  
DISCONNECT ALL POWER BEFORE SERVICING OR INSTALLING THIS UNIT. MULTIPLE POWER SOURCES MAY BE PRESENT. FAILURE TO DO SO MAY CAUSE PROPERTY DAMAGE, PERSONAL INJURY OR DEATH.



## CAUTION

IF NOX SCREENS ARE PRESENT, REMOVE AS PER INSTRUCTIONS IN SECTION "NOX SCREEN REMOVAL".



## CAUTION

TO PREVENT UNSATISFACTORY FURNACE OPERATION, THE PROPER GAS CONVERSION KIT MUST BE USED FOR THE GAS VALVE. USE THE WHITE-RODGERS SPRING KIT ONLY WITH THE WHITE-RODGERS GAS VALVE.

### NOTE: FOR LOW NOX MODELS, SEE TABLE OF CONTENTS FOR NOX SCREEN SECTION.

1. Turn off the gas supply to the furnace.
2. Turn off the electrical power to the furnace.
3. Remove the furnace control access panel.
4. Check for the presence of NOx screen and remove per NOx instruction.
5. Separate the gas supply union and remove associated downstream piping.
6. Always use a backup wrench when removing or replacing piping to avoid any undue strains or rotation of controls.
7. Remove the wires from the gas valve.
8. Remove the 4 sheet metal screws that fasten the manifold/gas valve assembly to the burner box.
9. Visually inspect orifices for damage and drill size (marked on face with 55) before installation. Using the 7/16" wrench, remove all existing natural gas orifices and replace with the appropriate marked 55 L.P. gas orifices contained in this kit. Tighten the orifices to prevent gas leaks, but do not overtighten. Retain the natural gas orifices for future reconversion.

10. Install water manometer using Valve Pressure Check Kit P/N 0151K00000S included with this kit. Using the included 3/32" hex wrench, rotate outlet pressure tap screw one revolution counterclockwise. Attach the included 5/16" hose to the inlet and outlet pressure boss of the valve. Hose should overlap boss 3/8". Connect 5/16" side of included connector to the hose on the outlet boss. Connect 1/4" side of the connector to the manometer hose. The manometer must have a scale range of at least 0" to 20" of water column.

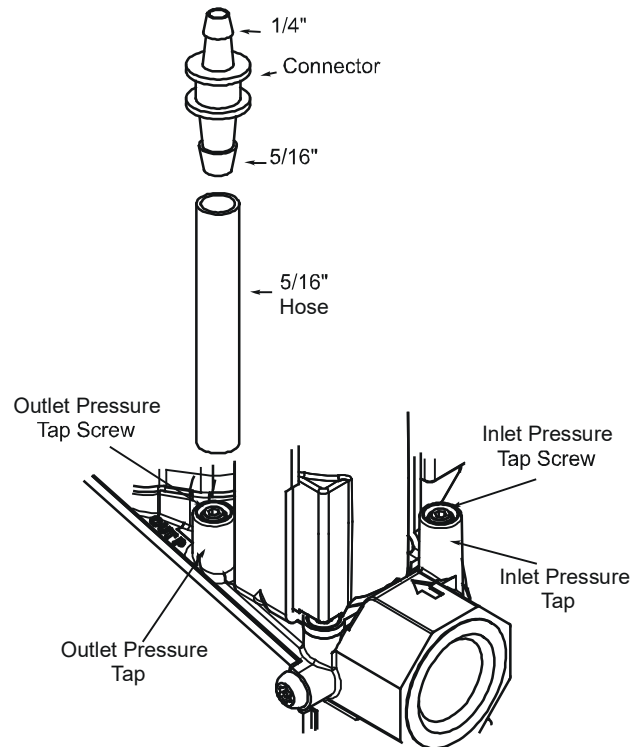

FIGURE 1

11. Remove both regulator cover screws.
12. Using a 1/4" flat blade screwdriver, remove both regulator adjustment screws (beneath the cover screws).
13. Remove both Natural Gas regulator springs (color-coded silver/plain) from regulator sleeves and retain with the Natural Gas orifices for future reconversion.
14. Insert the L.P. regulator springs (provided in the conversion kit and color-coded white) into the regulator sleeves.
15. Replace the High regulator adjustment screw and adjust it clockwise to bottom stop. Follow instructions below beginning in step 26 for checking & adjustment to verify manifold pressure falls into the desired range.
16. Replace the Low regulator adjustment screw and adjust it clockwise to bottom stop. Follow instructions below beginning in step 25 for checking & adjustment to verify manifold pressure falls into the desired range.
17. Reinstall the manifold/gas valve assembly into the appliance. Rewire the gas valve.
18. Apply a liberal amount of pipe joint compound or pipe thread tape to the threads and reassemble the piping previously removed.



## WARNING

TO PREVENT THE POSSIBILITY FOR GAS LEAKS, THE PIPE JOINT COMPOUND OR PIPE THREAD TAPE MUST BE RESISTANT TO L.P. GAS.

19. Turn on the gas supply.
20. Using a soap and water solution, check for leaks around the gas valve/manifold connection.
21. Turn on the electrical supply.
22. Adjust the room thermostat to obtain a first stage (W1 only) burner operation.  
**NOTE:** For hybrid models, the control board dip switches need to be set to 2 stage position to set and verify first stage heat. (See installation instructions supplied with the unit for dip switch settings.)



## WARNING

NEVER USE AN OPEN FLAME TO CHECK FOR GAS LEAKS.

23. Using a soap and water solution, check for leaks around the gas valve/manifold connection and the burner orifices. Repair any leaks before continuing.
24. **NOTE:** Any other gas-fired equipment should be ON before any adjustments are made.  
After the furnace has been in operation for 15 minutes, adjust the gas supply pressure (not manifold pressure) to obtain a range between 11" and 13" W.C. If the gas inlet pressure falls outside of this range, then make necessary L.P. service regulator(s) adjustments; check piping size, etc., and /or consult with L.P. provider.
25. With the furnace operating in its low-fire (W1) condition, the manifold pressure should be 6" W.C.  $\pm$  0.30". If necessary, this pressure can be adjusted using the gas valve low regulator adjustment screw. Turn clockwise to increase pressure and counterclockwise to decrease manifold pressure.
26. Readjust the room thermostat to obtain a second stage call for heat (W2). The manifold pressure for the W2 condition should be 10" W.C.  $\pm$  0.30" W.C. If necessary, this pressure can be adjusted using the gas valve high regulator adjustment screw. Turn clockwise to increase pressure and counterclockwise to decrease manifold pressure.
27. Using the room thermostat to cycle the unit, observe a minimum of three (3) smooth ignition cycles.
28. Turn off gas and electrical supply to the furnace, remove the manometer hose from the pressure tap bosses, and tighten the inlet and outlet pressure tap screws using the 3/32" Allen wrench.
29. Replace both regulator cover screws on the regulator sleeve.



## WARNING

ATTACHED THE WARNING LABEL PROVIDED IN THE KIT TO THE GAS VALVE WHERE IT CAN BE READILY SEEN. ATTACH THE SMALL, ROUND L.P. LABELS TO THE TOP OF THE REGULATOR COVER SCREWS.

30. **IMPORTANT NOTE:** Apply the conversion label (B14933-151) provided with the conversion kit. This label must be attached adjacent to the rating plate.
31. For hybrid models, control board switches may need to be re-set to single stage operation depending on installers preference of operation.
32. Reinstall the access panels.
33. Turn on the gas and electrical supply.
34. Reset all other appliances so they function normally.

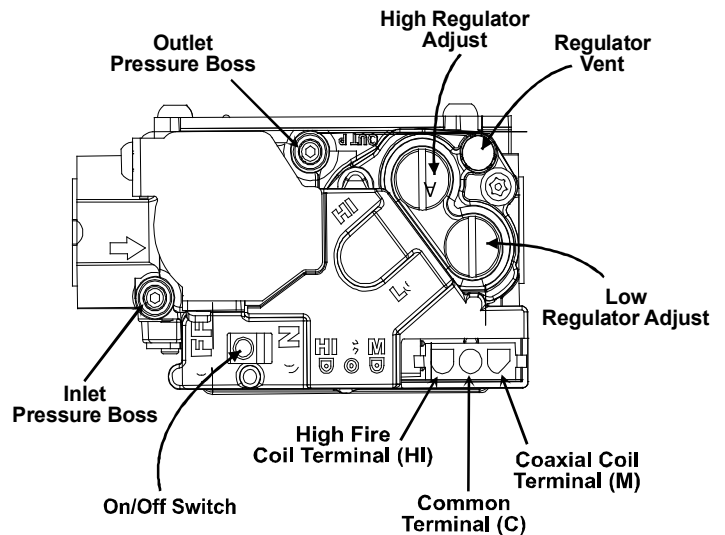

WHITE-RODGERS 36G54/36J54  
FIGURE 2

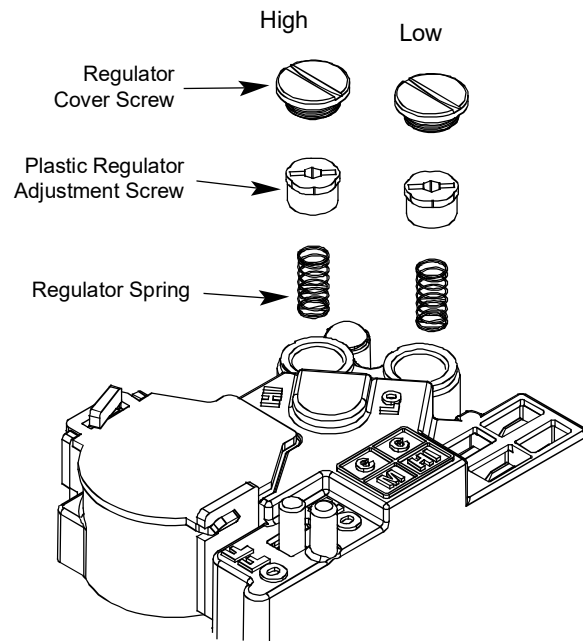

WHITE-RODGERS 36G54/36J54 SPRINGS AND REGULATOR SCREWS  
FIGURE 3



## NOX SCREEN REMOVAL



### WARNING

ALL METAL SCREENS MUST BE PERFORMED FROM THE HEAT EXCHANGER RUBES WHEN USING PROPANE GAS. FAILURE TO COMPLY WITH THIS REQUIREMENTS IS NOT COVERED UNDER THE WARRANTY.

**NOTE: TO PREVENT PREMATURE HEAT EXCHANGER FAILURE, FOLLOW THE INSTRUCTIONS BELOW TO REMOVE ALL METAL SCREEN INSERTS FROM THE ENTRANCE OF HEAT EXCHANGER TUBES DURING PROPANE CONVERSIONS. NOT ALL MODELS WILL HAVE METAL SCREEN INSERTS.**

## NON-CONDENSING FURNACES AND PACKAGE GAS-ELECTRIC

1. Remove the screws securing the burner box to the partition panel. Separate burner box from unit.
2. Remove the screw(s) securing the NOx screen retention plate and remove the plate.
3. Remove and discard NOx screens.
4. Reinstall the NOx screen retention plate and burner box.

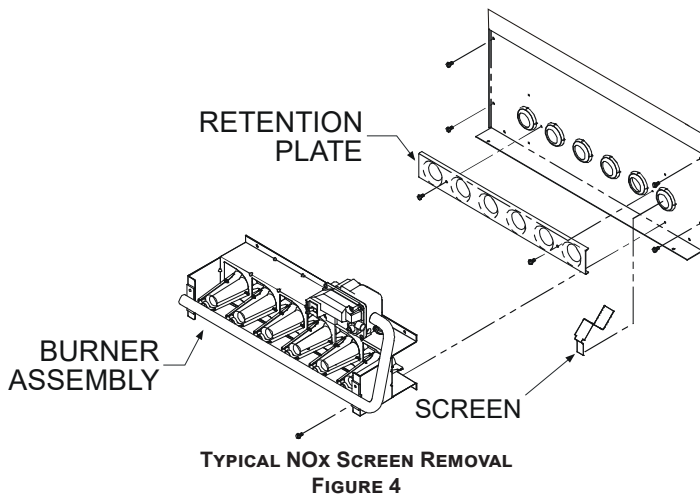

## LP LOW PRESSURE SWITCH INSTALLATION

### IMPORTANT INFORMATION

This kit provides control over the unit gas valve by routing the gas valve wiring through the supplied pressure switch. To enable proper fit-up, the pressure switch kit must be installed before connecting the gas supply line to the gas valve. For new unit installations, the kit hardware may be fitted to the gas valve while the gas manifold is removed for LP gas orifice conversion. For existing installations, the gas valve line must be disconnected from the gas valve to allow fitting of kit hardware. Refer to Figures 5 and 6 for a view of kit hardware as installed in unit. **Before proceeding, shut off gas supply at manual shutoff and turn off power to unit.**

**Contact a local propane gas supplier about installing a gas detecting warning device.**

**NOTE: TO ENSURE PROPER OPERATION, INSTALL, OPERATE AND MAINTAIN THE UNIT IN ACCORDANCE WITH THESE INSTALLATION INSTRUCTIONS, ALL LOCAL BUILDING CODES AND ORDINANCES. IN THEIR ABSENCE, FOLLOW THE LATEST EDITION OF THE NATIONAL FUEL GAS CODE (NFPA 54/ANSI Z223.1), AND/OR CAN/CSA B149.1 INSTALLATION CODES.**

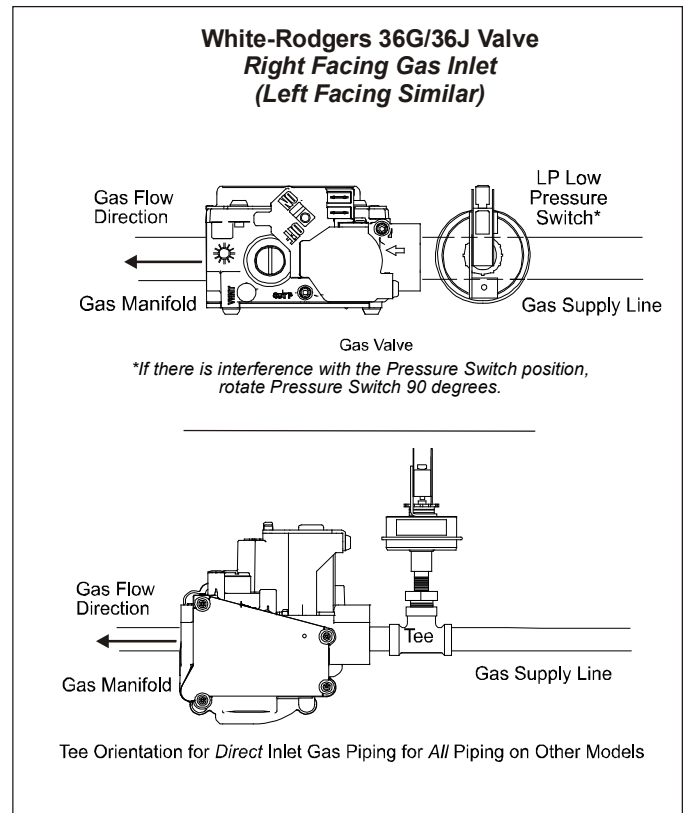

## FURNACES USING WHITE-RODGERS 36G/36J GAS VALVE

**NOTE: ALL THREADED CONNECTIONS MUST BE SEALED WITH TEFLON TAPE OR PIPE DOPE. PIPE SEALANT MUST BE APPROVED FOR USE WITH PROPANE GAS.**



### CAUTION

**TO AVOID THE RISK OF PROPERTY DAMAGE, PERSONAL INJURY OR FIRE, SHUT OFF GAS SUPPLY FIRST, THEN DISCONNECT THE ELECTRICAL SUPPLY BEFORE PROCEEDING WITH CONVERSION.**

1. Install field-supplied 90 degree street elbow into gas valve.
2. Install field-supplied 1/2" x length required to exit wrapper into 90 degree street elbow for left side gas outlet. Install field supplied 1/2" x length required to exit wrapper on the right side of the gas outlet (see Figure 6).

3. Place 1/2" tee on pipe.
4. With gas valve and manifold installed in the unit, connect the gas supply line into 1/2" tee as required (typically opposite of gas valve side).
5. Install 1/2" x 1/8" bushing into 1/2" tee in the remaining opening.
6. Install pressure switch in bushing. Pressure switch will be installed outside of the wrapper (see Figure 6).  
**NOTE:** Ensure that the switch is upright in all applications.
7. Perform installation check out procedure (piping leak check, line pressure measurement, manifold pressure adjustment, etc.) as outlined in the unit installation instructions.
8. Turn OFF gas supply.
9. Turn OFF power to furnace. Connect jumper harness between LPLP switch and gas valve and gas valve wiring as indicated in Figure 7 (two-stage models). Some two-stage models may require the use of long jumper wires to accommodate connection of the switch. (*2nd long jumper wire can be taken from long single stage harness*).  
**NOTE:** Do not run wires through the gas pipe opening if gas piping is present. Pipe could easily cause damage to the wires.
10. Turn ON power to furnace. Verify proper unit operation.
11. Remove backing from kit label. Fold label around jumper harness wire to indicate kit installation.
12. Adhere kit wiring diagram adjacent to existing unit wiring diagram.  
**IMPORTANT NOTE:** Secure all wires to avoid their contact with any hot surfaces or moving parts.

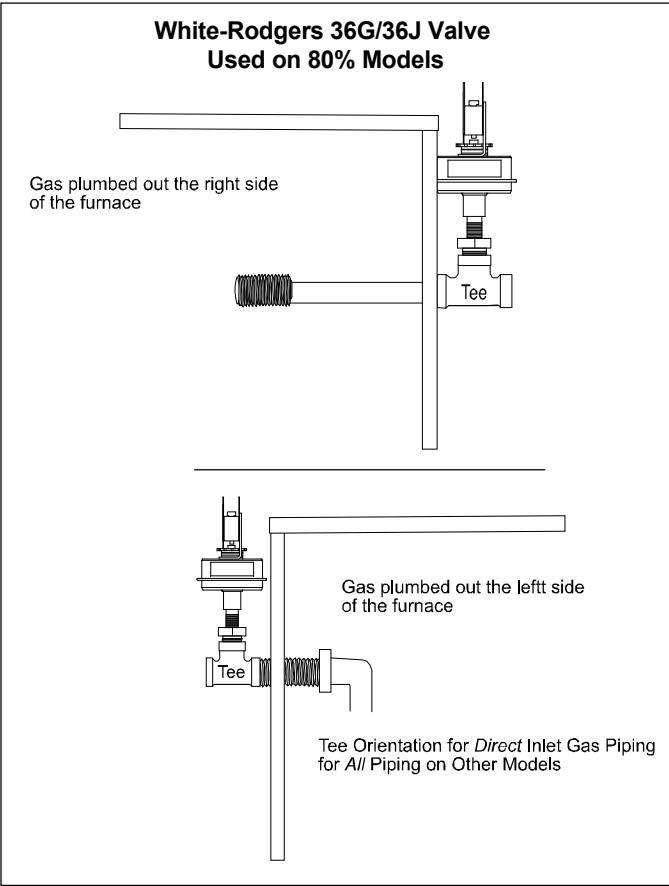

**FIGURE 6**

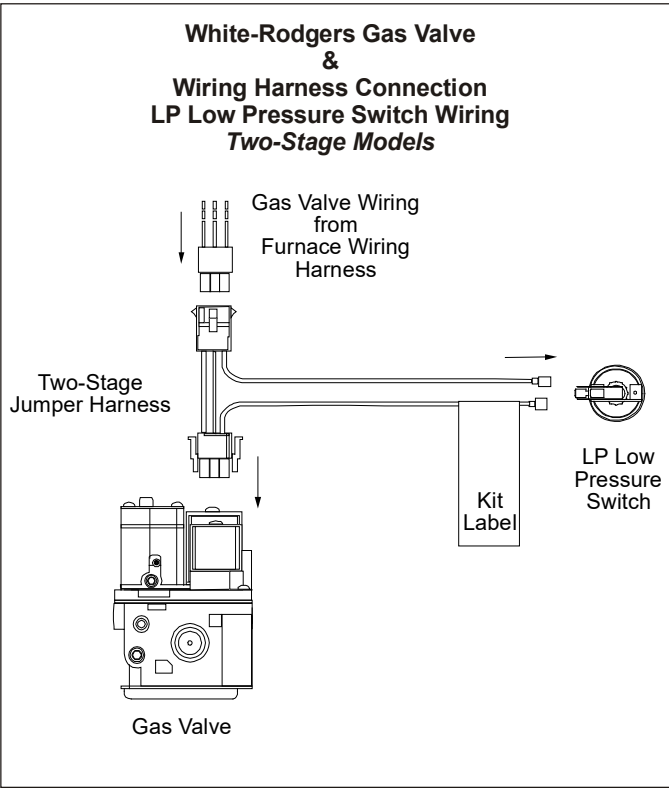

**FIGURE 7**

# TROUBLESHOOTING

If the furnace fails to light after installation of the LP low pressure switch kit, proceed as follows:

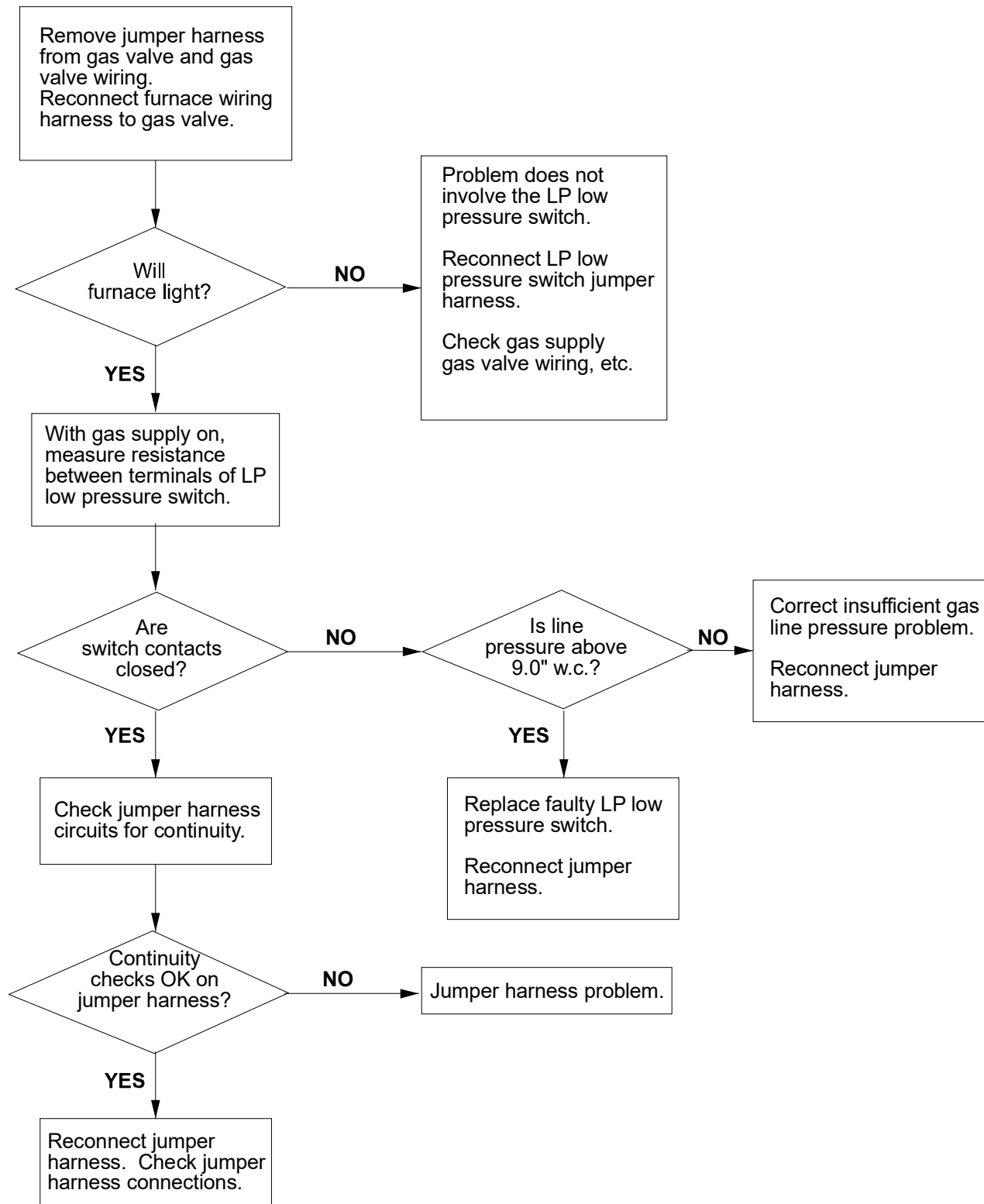

**CUSTOMER FEEDBACK**

We are very interested in all product comments.

Please fill out the feedback form on one of the following links:

Daikin Products: (<https://daikincomfort.com/contact-us>)

Goodman® Brand Products: (<http://www.goodmanmfg.com/about/contact-us>).

Amana® Brand Products: (<http://www.amana-hac.com/about-us/contact-us>).

You can also scan the QR code on the right for the product brand you purchased to be directed to the feedback page.



DAIKIN



GOODMAN® BRAND



AMANA® BRAND

NOTE: SPECIFICATIONS AND PERFORMANCE DATA LISTED HEREIN ARE SUBJECT TO CHANGE WITHOUT NOTICE

Visit our website at [www.daikincomfort.com](http://www.daikincomfort.com), [www.goodmanmfg.com](http://www.goodmanmfg.com) or [www.amana-hac.com](http://www.amana-hac.com) for information on:

- Products
- Parts
- Customer Services
- Warranties
- Financing Options
- Contractor Programs and Training

19001 Kermier Rd., Waller, TX 77484

[www.daikincomfort.com](http://www.daikincomfort.com) • [www.goodmanmfg.com](http://www.goodmanmfg.com) • [www.amana-hac.com](http://www.amana-hac.com)

© 2009-2011, 2013-2015, 2023 Daikin Comfort Technologies Manufacturing, L.P.

**Amana** is a trademark of Maytag Corporation and is used under license. All rights reserved.