



ECONOMIZER 101

Economizers are designed to provide “free” air conditioning when outside conditions are appropriate. When the outside air is cool and dry enough, the economizer automatically opens to introduce the cool air to the interior space, thereby eliminating the need to run the air conditioning compressor.

If the outside air becomes too warm or humid, the economizer automatically closes the fresh air damper and the compressor engages to begin cooling the space mechanically.

If a two stage thermostat is used it is possible to use a combination of economizer and mechanical cooling to condition the space.

The economizer can also be set to allow a minimum amount of fresh air to enter the space when the equipment’s indoor blower is operating.

Economizers are valuable tools to enhance indoor air quality, save energy and prolong the life of the air conditioning equipment.

SEQUENCE OF OPERATION

This sequence assumes employment of a single enthalpy economizer using a two stage thermostat.

1. A call for cooling comes from room thermostat.
2. The enthalpy sensor determines if the atmospheric conditions are conducive for using outside air for cooling. If YES, go to step 3. If NO, or if outdoor air temperature rises above enthalpy setpoint, go to step 4.
3. The outside air dampers open and modulate to maintain a mixed air temperature (outside air + indoor air) of 53 degrees F. If the outdoor air is insufficient to satisfy the thermostat alone and a second stage of cooling is required, the compressor starts and works in conjunction with the economizer to cool the space. In a system with two compressors, if the thermostat is still not satisfied by the economizer and stage 1 compressor, the Jade control will energize the second compressor. (go to step 5.)

4. Outdoor air dampers open to minimum position and the compressor engages to provide mechanical cooling.
5. When the thermostat is satisfied the outside air dampers return to a minimum position.

INSTALLATION

1. Open carton and inspect contents for shortages and damage.
2. Remove filter and upflow access panels from package unit. Keep all screws for re-use.
3. Per Figures 1 & 2, set the economizer into the unit's return cavity, then push economizer flanges up against the unit's flanges, until flush. The economizer has pre-punched holes to align with the upflow access panel holes.
4. Apply provided foam tape to the backside of the mounting flange of Hood Sides 1 & 2. Using retained screws and per Figure 3, screw Hood Side's 1 & 2 subassy's through the top two holes (per side) of the economizer's flange to the unit's existing holes, 4 places.
5. Apply provided foam tape to the backside of the flange of the Hood Divider. Per Figure 4, attach Hood Divider to Hood Sides using 4 provided screws.
6. Apply provided foam tape to the backside of the flange of the Hood Bottom. Using retained screws and per Figure 5, attach Hood Bottom through the bottom hole (per side) of the economizer's flange to the unit's existing holes, 2 places. Attach Hood Bottom to Hood Sides using 4 provided screws.
7. Per Figure 6, attach Baffle Sides to Hood Sides using 6 provided screws. Attach the Hood Baffle Front to the Divider and Baffle sides using 11 provided screws. Slide the Stabilizer Legs into place, block up underneath and bolt the two legs to the channels with provided bolts.
8. Per Figure 7, attach Hood Filter Top Stop to Hood Heel using 5 neoprene washer provided screws. Attach Hood Heel subassy to Hood Sides using 6 screws. Insert 2X Mist Eliminators into the Hood Assy, and retain with Pull-down Clips.
9. Per Figure 8, attach Hood Rain Guard to Hood Heel using 5X neoprene washer provided screws.

This product is warrantied to be free from defects due to workmanship or materials, under normal use, for a period of sixty (60) months from date of installation.

FIGURE 1

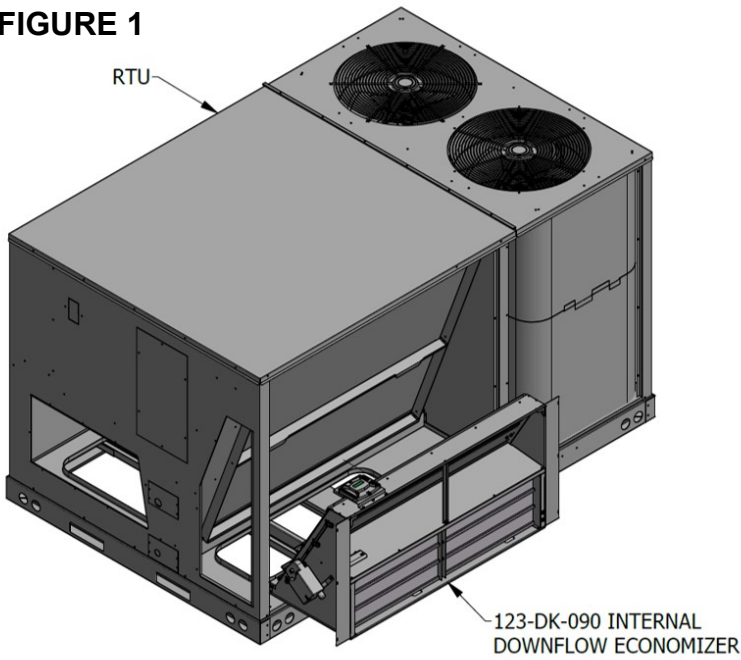
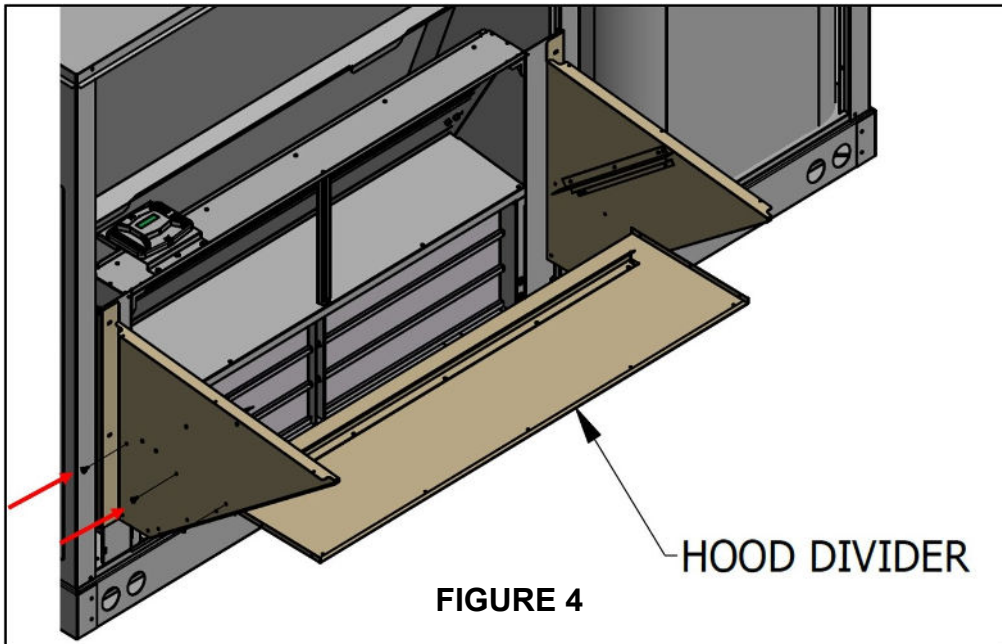
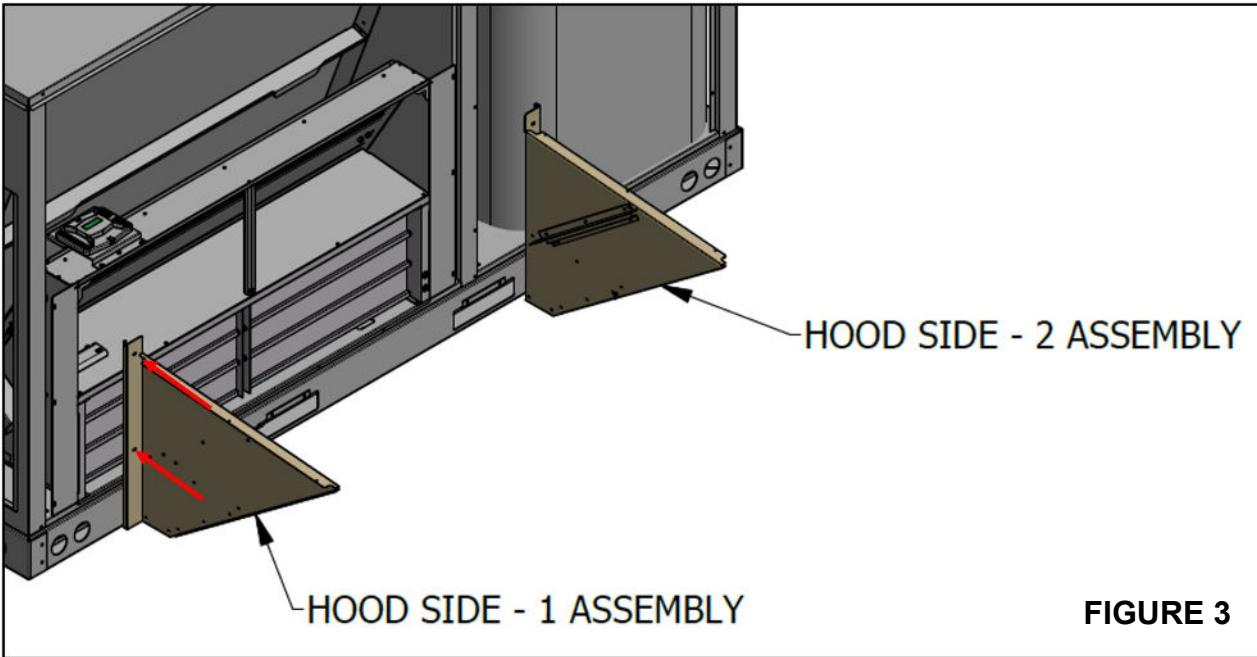
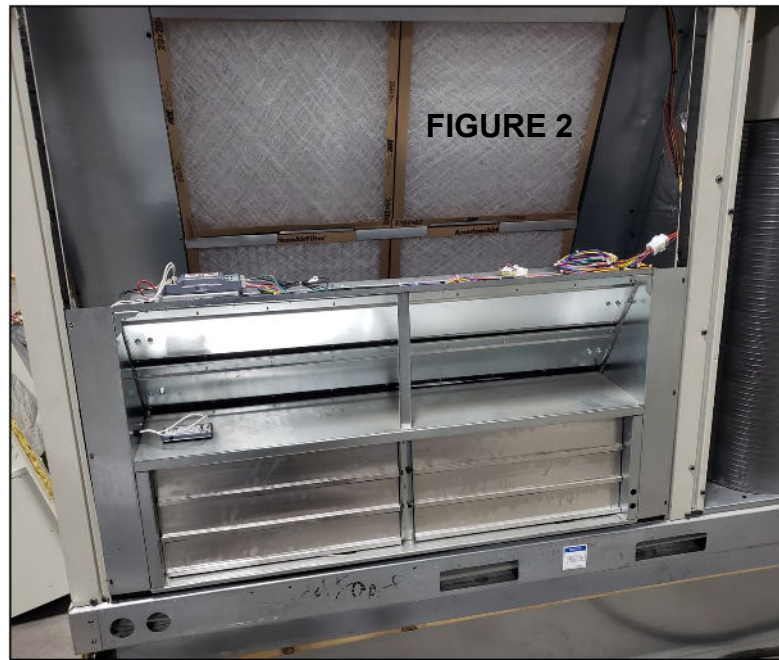
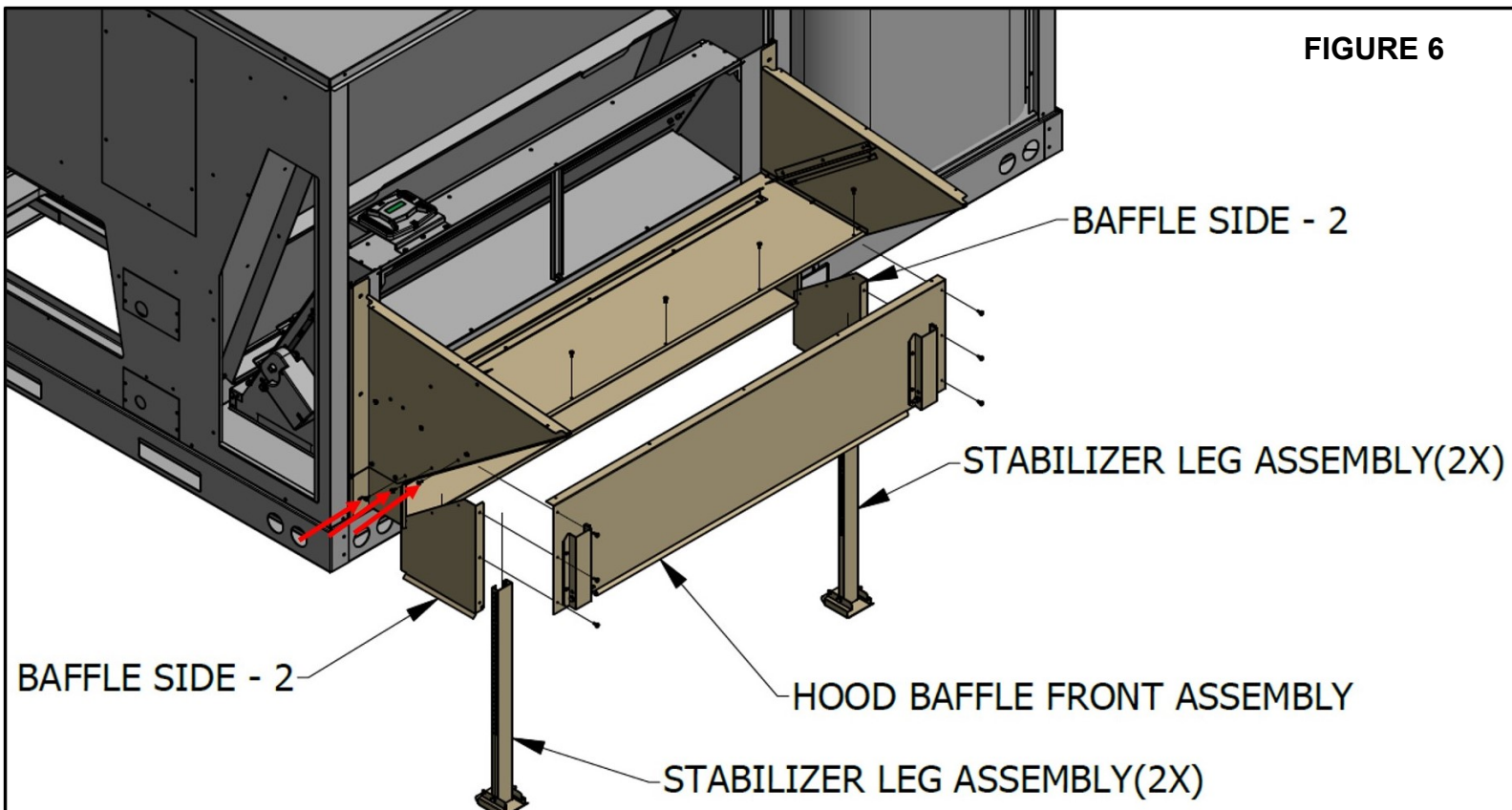
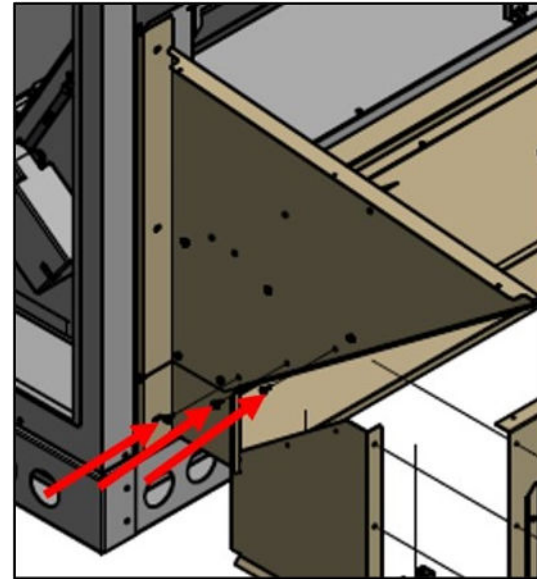
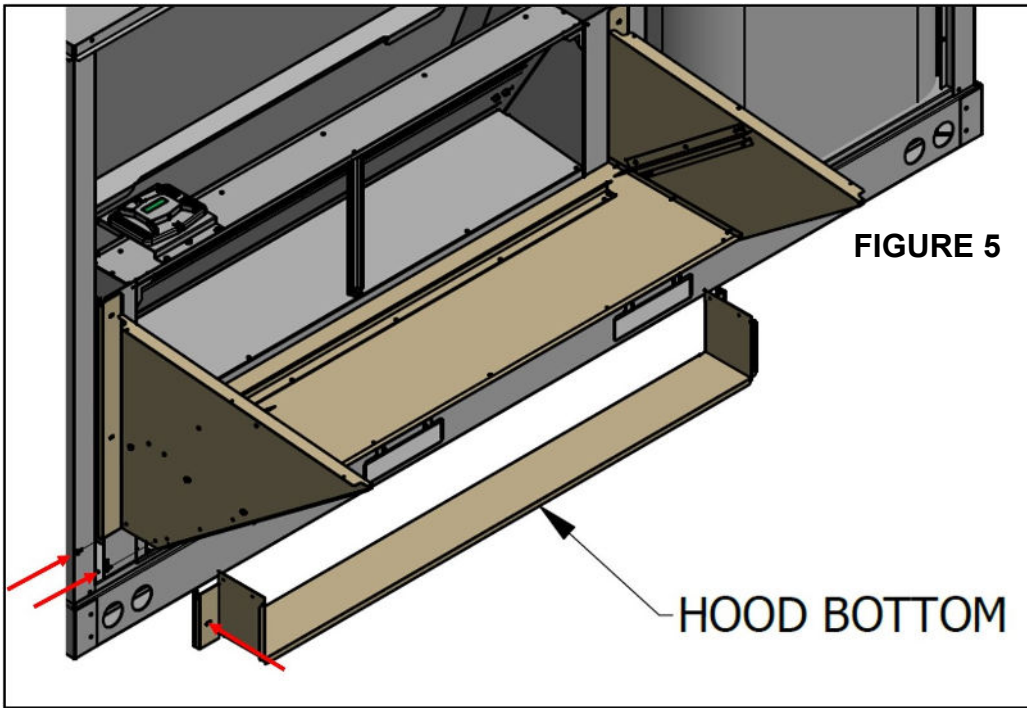
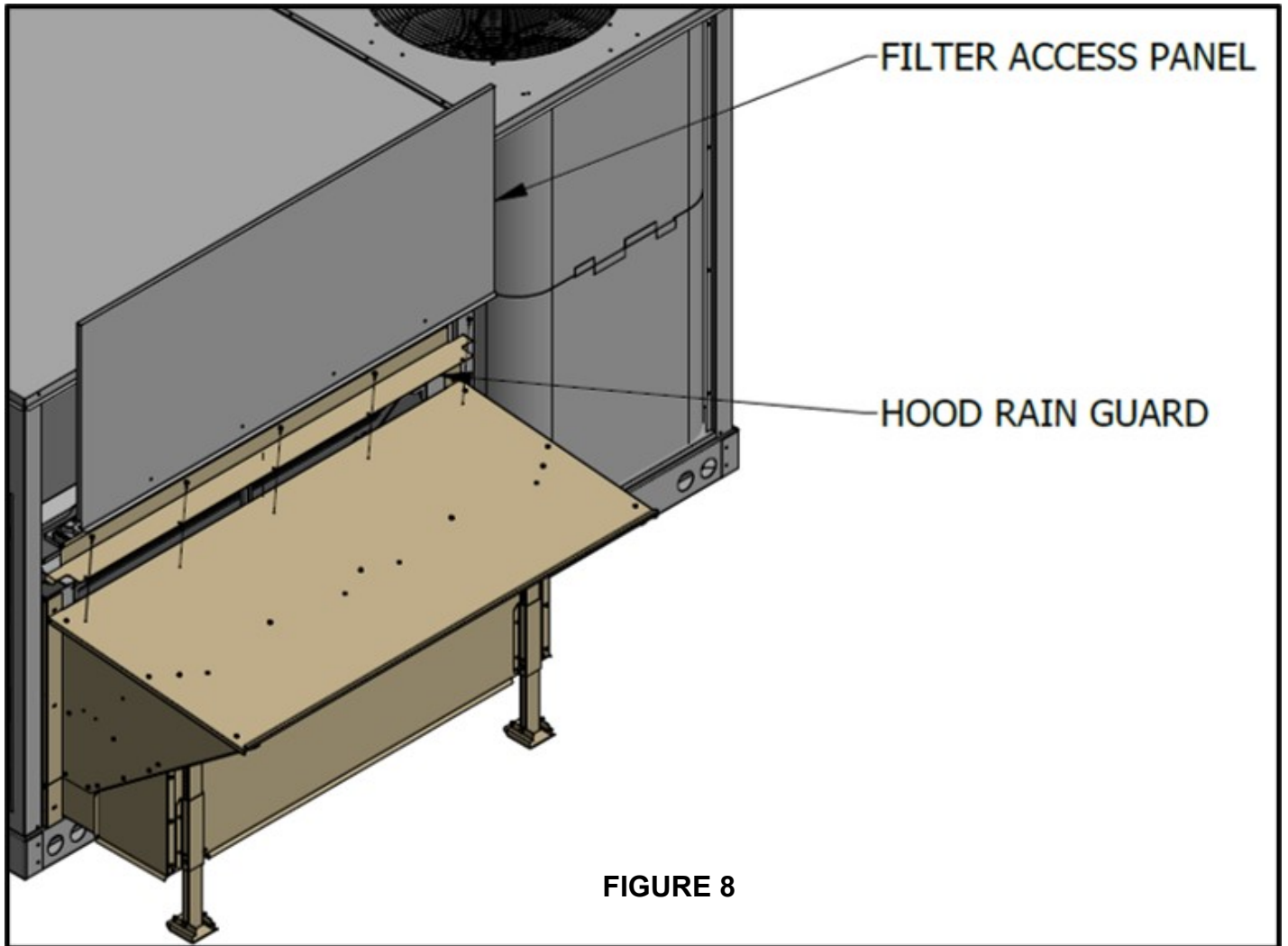
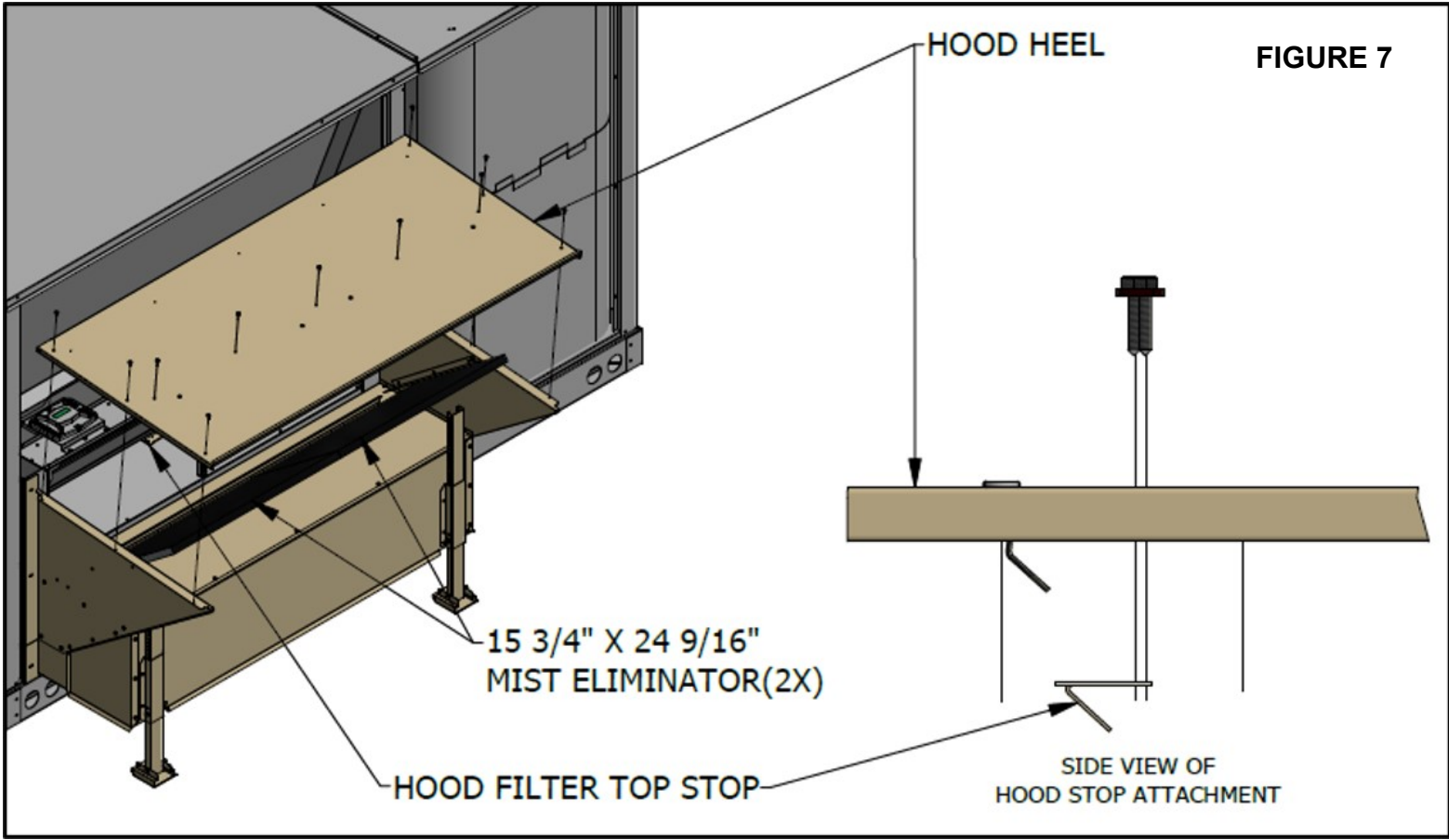

FIGURE 2







- Per Figure 9, remove the unit's jumper plug from its economizer harness located on the right side, and tape the jumper plug to the inside the return cavity, for future use. Route and plug the 12-pin economizer harness into matching 12-pin unit plug.

NOTE

Ensure neither the harness nor the plugs interfere with the movement of the dampers during operation. Tie-wrap harness so air filters can be accessed.

- Remove the blower access panel from the unit and locate the 2-pin MAT Sensor connector. Mount the provided Mixed Air Sensor to the blower housing per Figure 10, and plug the sensor into the 2-pin connector with the 4 ft. mixed air sensor wire harness (see Wire Diagram).
- Re-assemble the blower access panel with its screws.
- Power the unit and use the Honeywell Jade Economizer instructions provided and the 4 button interface on the Jade controller to configure the economizer for your application.
- Replace filter access panel on unit.



FIGURE 9

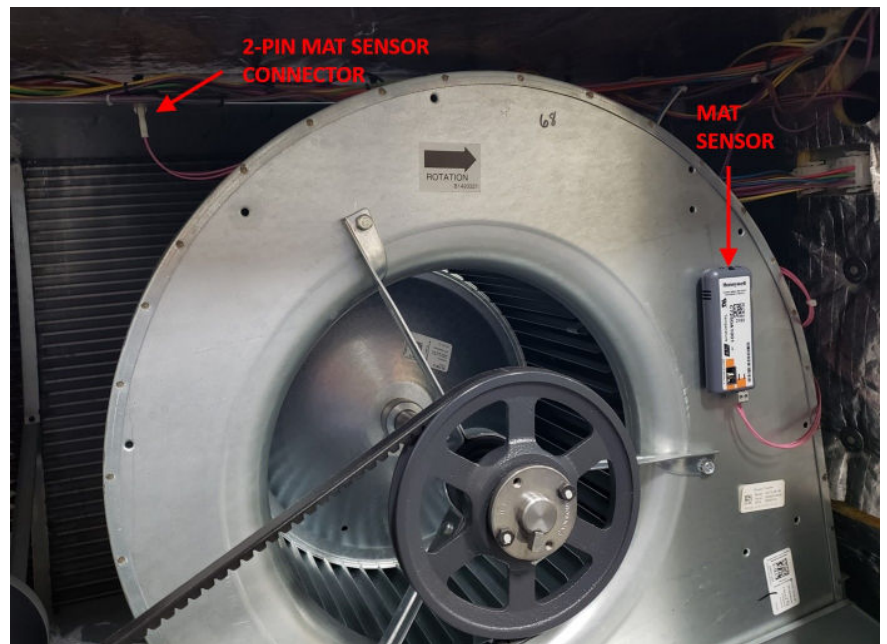

FIGURE 10

ACCESSORIES / CAPABILITIES

Dual Enthalpy - Requires an additional C7400 enthalpy control installed in the return air duct.

Demand Control Ventilation - Requires a CO2 sensor.

Power Exhaust - 144/145/146-DK-036 power exhaust used in applications where barometric relief is not sufficient.

Remote Minimum Positioner - For applications requiring minimum position adjustments inside the conditioned space.

CONTENTS	
QTY	DESCRIPTION
1	DAMPER w/ECONOMIZER CONTROLS
1	HOOD SIDE - 1 ASSEMBLY
1	HOOD SIDE - 2 ASSEMBLY
1	HOOD BOTTOM
1	RAIN GUARD
1	DIVIDER ASSEMBLY
1	HEEL ASSEMBLY
1	HOOD FILTER TOP STOP
1	HOOD BAFFLE SIDE 1
1	HOOD BAFFLE SIDE 2
1	HOOD BAFFLE FRONT
2	HOOD LEG ASSEMBLY
2	MIST ELIMINATOR
1	4 FT. PINK MIXED AIR SENSOR HARNESS
1	9 FT. PINK MIXED AIR SENSOR HARNESS
30	SHEET METAL SCREWS, #10 x 1/2" LG.
10	SCREWS WITH NEOPRENE WASHERS
1	C7250A1001 MIXED AIR SENSOR
2	1/4-20UNC X 2-3/4" LG. HEX HD BOLT
2	1/4-20UNC SELF-LOCKING NUT
1	JADE ECONOMIZER MANUAL
1	INSTALLATION INSTRUCTION

Important Notes

- Please see enclosed brochure for Honeywell component trouble shooting instructions as well as instructions for heat pump set up.
- The fresh air mist eliminator should be flushed periodically with warm soapy water.
- A two stage thermostat is recommended with this accessory.

The equation below may be used to set the minimum position. The mixed air temperature and outside air temperature may be discerned by looking at the status menu on the Jade controller.

MINIMUM SET POINT EQUATION

(To X OA) + (Tr X RA) = Tm
To = Outdoor air temperature
OA= Percent of outdoor air
Tr = Return air temperature
RA= Percent of return air
Tm= Resulting mixed air temperature

Example:
 Fresh air required is 10% outdoor air.
 Outdoor air temperature is 60 degrees F.
 Return air temperature is 75 degrees F.
 $(0.1 \times 60) + (0.9 \times 75) =$
 $6.0 + 67.5 = 73.5$
 Mixed air temperature will be 73.5 degrees F when the OA is 60 degrees F and the RA is 75 degrees F with 10% outdoor air.

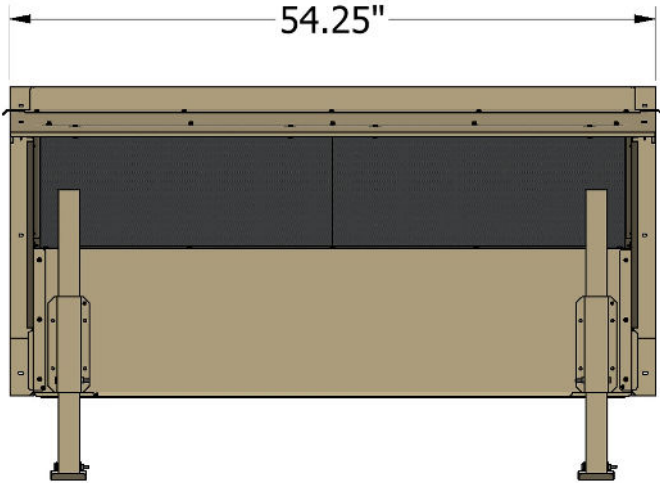
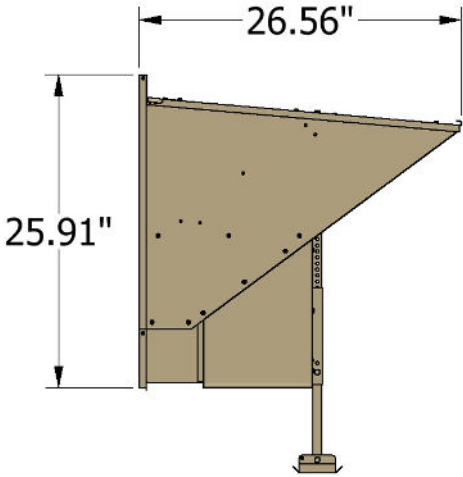

JADE W7220A1000 CONTROLLER - ALL SENSOR OPTIONS, Rev. 3, 04/18/23

(APPLIES TO 122/123/128-DK-036/036DB & 122/123/128-DK-090/090DB)

