



# KT-1700 Ice Kube Machine

KT-1700 ICE KUBE MACHINE

## Models

- KDT-1700A  
  KYT-1700A  
  KDT-1700W  
  KYT-1700W  
 KDT-1700N  
  KYT-1700N



Koolaire KT-1700  
Ice Kube Machine on K970 Bin

Koolaire by Manitowoc ice machines are designed, developed and tested by Manitowoc engineers to provide great ice production, energy efficiency and reliable service at an affordable price.

### Performance/Features/Benefits

- Produces up to 960 lbs (435 kg) of ice per day\*\*
- Performance certified by the Air Conditioning, Heating and Refrigeration Institute (AHRI)
- Energy Efficient models - visit EnergyStar.gov to view all Energy Star qualifying models
- Highly efficient electro-less nickel plated copper evaporators made in Manitowoc WI, USA
- Simple operation - only one control, three positions ON/OFF/CLEAN
- High-Tech exterior with smudge and fingerprint resistant stainless-like finish
- Better for the environment. Uses R410A refrigerant which lowers global warming potential by 48%
- Backed by the industry's best Manitowoc distribution network and service agents

### Built for Easy Sanitation

- Easy access front facing evaporator
- One-touch remedial cleaning; requires minimal interaction; just add chemical and let the machine do the rest. No ice removal from bin needed. (Use Manitowoc De-scaler and Sanitizer only)
- For detail cleaning; all food zone components removable by hand (no tools required). Fast and easy
- All white plastic interior, no exposed tubes or wires, smooth rounded corners for fast easy wipe downs
- The food zone is sealed from above and on the back of the door panel with commercial grade rubber gaskets
- Alpha San anti-microbial agent molded in selected components
- **Available LuminIce II Virus and Bacteria Inhibitor**- Controls viruses, bacteria, mold and yeast within the food zone to keep the machine clean longer (order K00520 for 22" & 30" and K00521 for 48" machines)

\*\*based on 70F air / 50F water

## Ice Machine Electric

203-208V / 60Hz / 1Ph

### Minimum circuit ampacity:

- Air-cooled: 18.1  
 Water-cooled: 16.5  
 Remote Air-cooled: 15.2

### Maximum fuse size:

- Air-cooled: 30 amps  
 Water-cooled: 25 amps  
 Remote Air-cooled: 25 amps

## Specifications

**BTU Per Hour:**  
23,400 (average)  
and 25,200 (peak)

### Refrigerant:

R410A CFC - Free  
Lowers global warming  
by 48%

### Operating Limits:

- Ambient Temperature Range: 40° to 110° F (4.4° to 43.3° C)  
Water Temperature Range: 40° to 90° F (4.4° to 32.2° C)
- Water Pressure Ice Maker Water In:  
Min. 20 psi (137.9 kPa)  
Max. 80 psi (551.1 kPa)

## Ice Shape



**HALF KUBE**  
3/8" x 1 1/8" x 7/8"  
(.95 x 2.86 x 2.22 cm)

❄️ = 100%



**KUBE**  
7/8" x 7/8" x 7/8"  
(2.22 x 2.22 x 2.22 cm)

❄️ = 100%



## KT1700 on K-970 Storage Bin

**Required Clearance:**  
Top/Sides: 8" (20.3 cm)  
Back: 5" (12.7 cm)

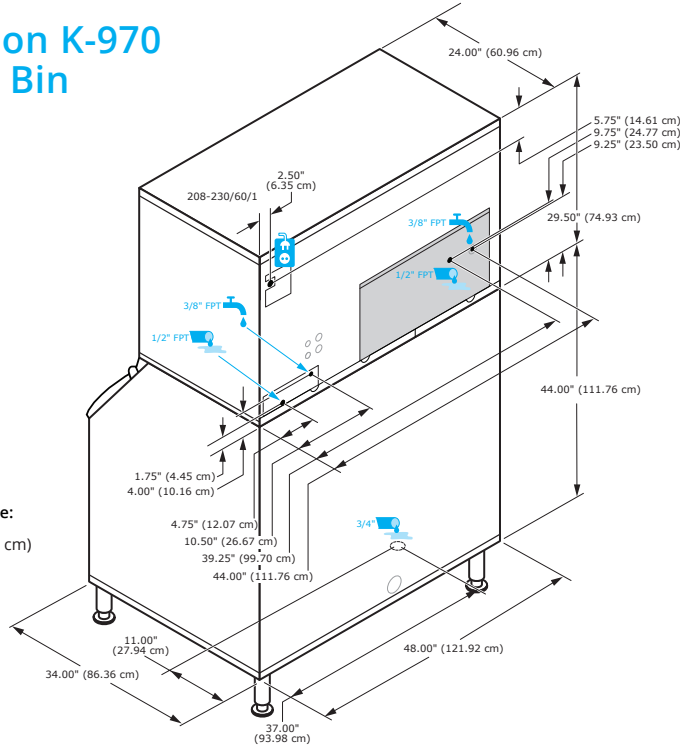

## Space-Saving Design



**KT1700  
K-970**

Height 79.5"  
202.93 cm

Width 48.00"  
121.92 cm

Depth 34.00"  
86.30 cm

Bin 882 lbs.  
Storage 400 kgs.

*Measurements with bin legs at 6.00" (15.24cm).  
Adjustable bin legs 6.00" to 8.00" (15.24cm to 20.32cm). Bin capacity is based on 90% of the volume x 33 lbs/ft<sup>3</sup> average density of ice.*

Water cooled condenser water usage/100 lbs. or 45.5 Kg. of ice: 145 gals. / 549L.

## Specifications

	Model	Ice Shape	Ice Production 24 Hours		Power Usage kWh/100 lbs. @90°Air/70°F	Potable Water Usage/100 lbs. 45.4 kgs. of Ice
			70°/ 50°F 21°/ 10°C	90°/ 70°F 32°/ 21°C		
AIR COOLED	KDT-1700A	kube	1652 lbs.	1326 lbs.	4.70	20 Gal. 75.7 L
		half-kube	749 kgs	601 kgs		
WATER COOLED	KYT-1700A	kube	1652 lbs.	1334 lbs.	4.66	20 Gal. 75.7 L
		half-kube	749 kgs	605 kgs		
REMOTE COOLED	KDT-1700W	kube	1600 lbs.	1400 lbs.	3.61	20 Gal. 75.7 L
		half-kube	726 kgs	635 kgs		
WATER COOLED	KYT-1700W	kube	1555 lbs.	1421 lbs.	3.49	20 Gal. 75.7 L
		half-kube	705 kgs.	645 kgs		
REMOTE COOLED	KDT-1700N	kube	1680 lbs	1380 lbs	4.26	20 Gal. 75.7 L
		half-kube	762 kg	626 kg		
REMOTE COOLED	KYT-1700N	kube	1740 lbs	1477 lbs	4.06 ★	20 Gal. 75.7 L
		half-kube	789 kg	670 kg		

Order ice machine and bin separately.

For "N" models order Manitowoc JCT1500-261 remote condenser.

★ indicates Energy Star 3.0 certified.

### Shipping Weight:

Air-cooled: 333 lbs (151 kg)  
Water-cooled: 337 lbs (153 kg)  
Remote Air-cooled: 311 lbs (141 kg)



## Accessories

**Dispenser Bin Thermostat Kit**  
Reduces condensation when used with dispensers.



**Top Air Discharge Kit**  
Convert air flow to rear in-take / top exhaust.

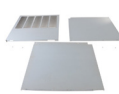

**Arctic Pure® Water Filters**  
Reduces sediment and chlorine odors for better tasting ice.



**Luminice II Virus and Bacteria Inhibitor**  
controls viruses and bacteria inside the ice machine



Welbilt reserves the right to make changes to the design or specifications without prior notice.