



KT-0400 ICE KUBE MACHINE

# KT-0400 Ice Kube Machine

## Models

- KDT-0400A  KYT-0400A  KDT-0400W  KYT-0400W



Koolaire KT-0400  
Ice Kube Machine on K400 Bin

Koolaire by Manitowoc ice machines are designed, developed and tested by Manitowoc engineers to provide great ice production, energy efficiency and reliable service at an affordable price.

### Performance/Features/Benefits

- Produces up to 960 lbs (435 kg) of ice per day\*\*
- Performance certified by the Air Conditioning, Heating and Refrigeration Institute (AHRI)
- Energy Efficient models - visit EnergyStar.gov to view all Energy Star qualifying models
- Highly efficient electro-less nickel plated copper evaporators made in Manitowoc WI, USA
- Simple operation - only one control, three positions ON/OFF/CLEAN
- High-Tech exterior with smudge and fingerprint resistant stainless-like finish
- Better for the environment. Uses R410A refrigerant which lowers global warming potential by 48%
- Backed by the industry's best Manitowoc distribution network and service agents

### Built for Easy Sanitation

- Easy access front facing evaporator
- One-touch remedial cleaning; requires minimal interaction; just add chemical and let the machine do the rest. No ice removal from bin needed. (Use Manitowoc De-scaler and Sanitizer only)
- For detail cleaning; all food zone components removable by hand (no tools required). Fast and easy
- All white plastic interior, no exposed tubes or wires, smooth rounded corners for fast easy wipe downs
- The food zone is sealed from above and on the back of the door panel with commercial grade rubber gaskets
- Alpha San anti-microbial agent molded in selected components
- **Available LuminIce II Virus and Bacteria Inhibitor**- Controls viruses, bacteria, mold and yeast within the food zone to keep the machine clean longer (order K00520 for 22" & 30" and K00521 for 48" machines)

\*\*based on 70F air / 50F water

## Ice Machine Electric

115/60/1 standard  
(air cooled also available in 208-230V)

### Minimum circuit ampacity:

Air-cooled: 12.1 (115V) 6.2 (208-230V)  
Water-cooled: 11.4 (115V)

### Maximum fuse size:

Air Cooled: 20 Amps (115V) 15 Amps (208-230V)  
Water cooled: 20 Amps (115V)

## Specifications

### Operating Limits:

- Ambient Temperature Range: 40° to 110°F (4.4° to 43.3°C)  
Water Temperature Range: 40° to 90°F (4.4° to 32.2°C)
- Water Pressure Ice Maker Water In:  
Min. 20 psi (137.9 kPa)  
Max. 80 psi (551.1 kPa)

**BTU Per Hour:**  
3,800 (average),  
and 6,000 (peak)

**Refrigerant:**  
R410A CFC - Free  
Lowers global warming  
by 48%

## Ice Shape



**HALF KUBE**  
3/8" x 1 1/8" x 7/8"  
(.95 x 2.86 x 2.22 cm)

❄ = 100%



**KUBE**  
7/8" x 7/8" x 7/8"  
(2.22 x 2.22 x 2.22 cm)

❄ = 100%



AutoQuotes



## KT0400 on K-400 Storage Bin

**Required Clearance:**  
Top/Sides: 8" (20.3 cm)  
Back: 5" (12.7 cm)

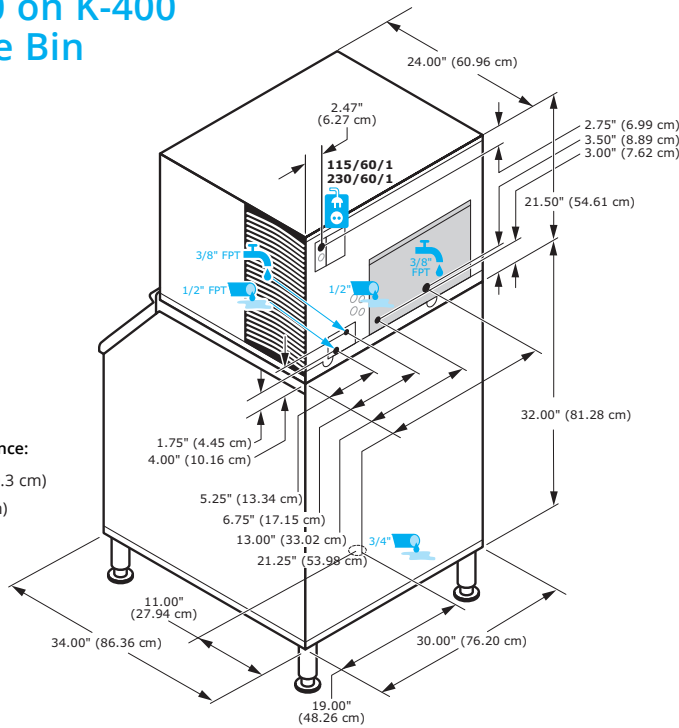

## Space-Saving Design



	<b>KT0400 K-400</b>
Height	59.50" 151.13 cm
Width	30.00" 76.2 cm
Depth	34.00" 86.30 cm
Bin Storage	365 lbs. 165.7 kgs.

Measurements with bin legs at 6.00" (15.24cm).  
Adjustable bin legs 6.00" to 8.00" (15.24cm to 20.32cm). Bin capacity is based on 90% of the volume x 33 lbs/ft<sup>3</sup> average density of ice.

Water cooled condenser water usage/100 lbs. or 45.4 Kg. of ice: 160 gals. / 606L.

## Specifications

	Model	Ice Shape	Ice Production 24 Hours		Power Usage kWh/100 lbs. @90°Air/70°F 1 Ph	Potable Water Usage/100 lbs. 45.4 kgs. of Ice
			70°/ 50°F 21°/ 10°C	90°/ 70°F 32°/ 21°C		
<b>AIR COOLED</b>	KDT-0400A	kube	440 lbs.	345 lbs.	6.1	19 Gal. 71.9 L
			199 kgs	156 kgs		
	KYT-0400A	half-kube	450 lbs.	350 lbs.	5.6 ★	19 Gal. 71.9 L
			204 kgs	159 kgs		
<b>WATER COOLED</b>	KDT-0400W	kube	425 lbs.	360 lbs.	4.6	19 Gal. 71.9 L
			193 kgs	163 kgs		
	KYT-0400W	half-kube	422 lbs.	360 lbs.	4.7	19 Gal. 71.9 L
			191 kgs.	163 kgs		

Order ice machine and bin separately  
★ indicates Energy Star 3.0 certified

### Shipping Weight:

Air-cooled: 155 lbs (71kg)  
Water-cooled: 162 lbs (74 kg)



## Accessories

### Dispenser Bin Thermostat Kit

Reduces condensation when used with dispensers.



### Top Air Discharge Kit

Convert air flow to rear in-take / top exhaust.

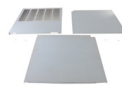

### Arctic Pure Plus® Water Filters

reduce sediments and chlorine contaminants down to .5 microns. Use with a Pre-filter is recommended.



**Luminice II Virus and Bacteria Inhibitor** controls viruses and bacteria inside the ice machine



Welbilt reserves the right to make changes to the design or specifications without prior notice.