

LOW PROFILE UNIT COOLERS

Technical Guide

Models ADT | Air Defrost • LET/LLE | Electric Defrost • HGT | Hot Gas Defrost

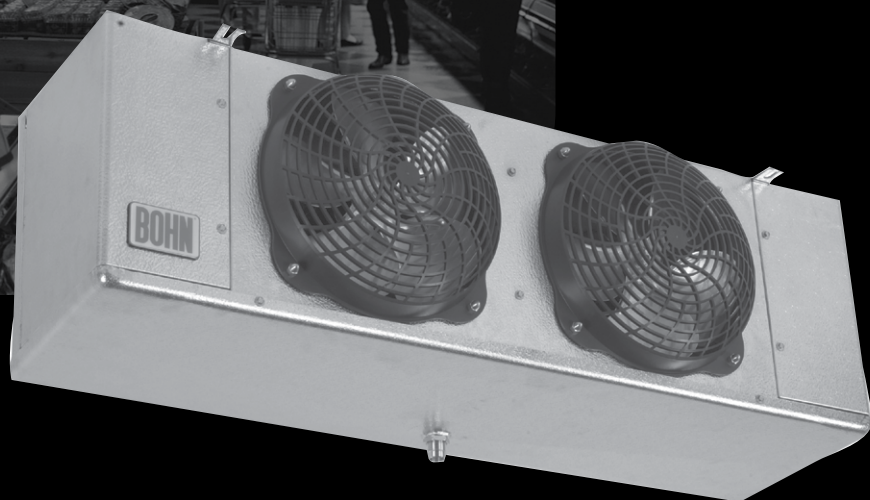

Table of Contents

Nomenclature.....2

Features & Benefits3

Performance Data & Specifications

 Air Defrost4-5

 Electric Defrost6-7

 Hot Gas Defrost.....8-9

Physical Data.....10-11

Dimensional Data.....12

Hot Gas Reverse Cycle Kits.....13-14

3-Pipe Hot Gas Defrost.....15

Replacement Parts by InterLink™16

Standard Nozzle Selection.....17



We have made a commitment to customer needs, innovation and environmental stewardship and have dedicated ourselves to delivering energy-efficient choices. PSC and EC motors will reduce costs, improve the bottom line and enhance equipment performance and service life.

Choose the most energy-efficient motor available for evaporators.



The EC motor is an Energy Solutions® option on new Bohn Low Profile evaporators. Available on all new equipment or as an easy-to-install, drop-in replacement aftermarket part from InterLink™ Commercial Refrigeration Parts. Because they're a drop-in replacement for existing shaded pole and PSC motors, installation is quick and easy. It's a **high impact, quick payback solution** for reducing costs and achieving green initiatives **without replacing the entire system.**

EC motors by InterLink are **up to 75% efficient** - that's a **51-59% increase over shaded pole motors** and a **30-35% increase over permanent-split capacitor (PSC) motors.** With all of this added efficiency, you can count on more **energy savings and lower operational costs** while taking a step in the right direction toward conserving our planet's resources.

To learn more about EC motors, visit www.interlinkparts.com/ec.

Nomenclature

ADT	120	A	K
Model Series	Capacity	Electrical Code	Design Revision
ADT = Air defrost LET = Electric defrost, 6 FPI LLE = Electric defrost, 4 FPI HGT = Hot gas defrost	# x 100 = BTUH	A = 115/1/60 B = 208-230/1/60 C = 208-230/3/60 M = 460/1/60 AH = 115/1/60 (PSC) BH = 208-230/1/60 (PSC) AE = 115/1/60 (EC) BE = 208-230/1/60 (EC) CE = 208-230/3/60 (EC)	

Features & Benefits

Cabinet

- Minimal height of the low profile series makes it ideal for low ceiling coolers
- Cabinet design features front access panels on each side for easy access to electrical and refrigeration components
- All electrical components factory wired to terminal board and identified, making it easy to field wire the unit
- Sweat connections to reduce potential for leaks
- Internal panels are isolated for quiet operation
- Liquid line solenoid wire harness is factory-installed for quick installation
- Pre-drilled holes on the back of the unit for room thermostat

Coil

- Internally enhanced tubing and fin design for higher efficiency
- Coil heater slots have been enlarged for easier installation and replacement
- Reduced heater wattages
- Hot gas loop on bottom of coil for easier access is standard for hot gas defrost models
- Fixed defrost termination for electric, adjustable defrost termination for hot gas

Drain Pan

- Large diameter drain hole (3/4" ID) is located on the back of the unit
- Extended drain pan heaters for more uniform defrost throughout the drain pan and additional heat in end compartments
- On 4-6 fan models, drain pan has a lanyard for easy and safe access

Motors

- Motors plug into wiring harness for easier servicing
- EC motors available factory-installed or as a drop-in replacement through InterLink™ Commercial Refrigeration Parts in 115/1/60, 208-230/1/60 and 208-230/3/60 unit voltages
- PSC and PSC (Totally Enclosed) motors for 115/1/60, 208-230/1/60 and 460/1/60 unit voltages
- PSC motors or EC motors required for 50 Hz operation

Options

- Unit Configurations: mounted components, pre-assembled, pre-charged and Beacon II™
 - Units available with mounted TXV and mounted TXV / solenoid valve
 - Pre-assembled units come with mounted TXV, liquid line solenoid valve and room thermostat. Available in a master liquid line configuration
 - Pre-charged units come with mounted TXV, liquid line solenoid valve, room thermostat and quick connect fittings
 - Various room thermostat variations including rear mount and front access versions
 - Beacon II units come with electronic expansion valves, pressure transducer, temperature sensors and Beacon control board
- Most models available with glycol circuiting (see glycol product brochure)
- Units available with stainless steel housing and drain pan
- Units available with copper fins. Air defrost units also available with polyester coated fins or various coil coatings options
- Units available with insulated drain pan

Performance Data

Model ADT Air Defrost | 60 Hz

Model	Capacity		Fan Data		
	10°F TD 25°F SST	6°C TD -4°C SST	No.	CFM	m ³ H
	BTUH	Watts			
ADT040	4,000	1,170	1	730	1,240
ADT052	5,200	1,520	1	700	1,189
ADT065	6,500	1,900	1	650	1,104
ADT070	7,000	2,050	2	1,460	2,481
ADT090	9,000	2,640	2	1,400	2,379
ADT104	10,400	3,050	2	1,400	2,379
ADT120	12,000	3,500	2	1,300	2,209
ADT130	13,000	3,810	2	1,300	2,209
ADT140	14,000	4,100	3	2,100	3,568
ADT156	15,600	4,570	3	2,100	3,568
ADT180	18,000	5,270	3	1,950	3,313
ADT208	20,800	6,100	4	2,800	4,758
ADT260	26,000	7,620	5	3,250	5,522
ADT312	31,200	9,140	6	3,900	6,627
ADT370	37,000	10,840	6	3,900	6,627

Model ADT Air Defrost | 50 Hz †

Model	Capacity		Fan Data		
	10°F TD 25°F SST	6°C TD -4°C SST	No.	CFM	m ³ H
	BTUH	Watts			
ADT040	3,800	1,112	1	670	1,117
ADT052	4,940	1,445	1	630	1,070
ADT065	6,175	1,807	1	586	995
ADT070	6,650	1,946	2	1,315	2,234
ADT090	8,550	2,502	2	1,260	2,142
ADT104	9,880	2,891	2	1,260	2,142
ADT120	11,400	3,335	2	1,170	1,989
ADT130	12,350	3,613	2	1,170	1,989
ADT140	13,300	3,891	3	1,891	3,213
ADT156	14,820	4,336	3	1,891	3,213
ADT180	17,100	5,003	3	1,756	2,984
ADT208	19,760	5,781	4	2,521	4,284
ADT260	24,700	7,226	5	2,927	4,973
ADT312	29,640	8,672	6	3,512	5,967
ADT370	35,150	10,284	6	3,512	5,967

† For EC motors, use 60 Hz capacity and airflow values (Units with EC motors operating at 50 Hz will not see a reduction in performance due to the electronic control of the motor)

Specifications

Model ADT Air Defrost | 60 Hz

Model	HP	Shaded Pole Motor				PSC, PSC-TE Motor						EC Motor			
		115/1/60		208-230/1/60		115/1/60		208-230/1/60		460/1/60		115/1/60		208-230/1/60	
		Amps	Watts	Amps	Watts	Amps	Watts	Amps	Watts	Amps	Watts	Amps	Watts	Amps	Watts
ADT040	1/15	1.8	116	1.0	122	1.0	82	0.5	91	0.4	117	0.9	57	0.5	59
ADT052	1/15	1.8	116	1.0	122	1.0	82	0.5	91	0.4	117	0.9	57	0.5	59
ADT065	1/15	1.8	116	1.0	122	1.0	82	0.5	91	0.4	117	0.9	57	0.5	59
ADT070	1/15	3.6	232	2.0	244	2.0	164	1.0	182	0.8	234	1.8	114	1.0	118
ADT090	1/15	3.6	232	2.0	244	2.0	164	1.0	182	0.8	234	1.8	114	1.0	118
ADT104	1/15	3.6	232	2.0	244	2.0	164	1.0	182	0.8	234	1.8	114	1.0	118
ADT120	1/15	3.6	232	2.0	244	2.0	164	1.0	182	0.8	234	1.8	114	1.0	118
ADT130	1/15	3.6	232	2.0	244	2.0	164	1.0	182	0.8	234	1.8	114	1.0	118
ADT140	1/15	5.4	348	3.0	366	3.0	246	1.5	273	1.2	351	2.7	171	1.5	177
ADT156	1/15	5.4	348	3.0	366	3.0	246	1.5	273	1.2	351	2.7	171	1.5	177
ADT180	1/15	5.4	348	3.0	366	3.0	246	1.5	273	1.2	351	2.7	171	1.5	177
ADT208	1/15	7.2	464	4.0	488	4.0	328	2.0	364	1.6	468	3.6	228	2.0	236
ADT260	1/15	9.0	580	5.0	610	5.0	410	2.5	455	2.0	585	4.5	285	2.5	295
ADT312	1/15	10.8	696	6.0	732	6.0	492	3.0	546	2.4	702	5.4	342	3.0	354
ADT370	1/15	10.8	696	6.0	732	6.0	492	3.0	546	2.4	702	5.4	342	3.0	354

Model ADT Air Defrost | 50 Hz

Model	HP	PSC Motor						EC Motor			
		110/1/50		220/1/50		380/1/50		110/1/50		220/1/50	
		Amps	Watts	Amps	Watts	Amps	Watts	Amps	Watts	Amps	Watts
ADT040	1/15	1.0	68	0.5	65	0.4	82	0.9	57	0.5	59
ADT052	1/15	1.0	68	0.5	65	0.4	82	0.9	57	0.5	59
ADT065	1/15	1.0	68	0.5	65	0.4	82	0.9	57	0.5	59
ADT070	1/15	2.0	136	1.0	130	0.8	164	1.8	114	1.0	118
ADT090	1/15	2.0	136	1.0	130	0.8	164	1.8	114	1.0	118
ADT104	1/15	2.0	136	1.0	130	0.8	164	1.8	114	1.0	118
ADT120	1/15	2.0	136	1.0	130	0.8	164	1.8	114	1.0	118
ADT130	1/15	2.0	136	1.0	130	0.8	164	1.8	114	1.0	118
ADT140	1/15	3.0	204	1.5	195	1.2	246	2.7	171	1.5	177
ADT156	1/15	3.0	204	1.5	195	1.2	246	2.7	171	1.5	177
ADT180	1/15	3.0	204	1.5	195	1.2	246	2.7	171	1.5	177
ADT208	1/15	4.0	272	2.0	260	1.6	328	3.6	228	2.0	236
ADT260	1/15	5.0	340	2.5	325	2.0	410	4.5	285	2.5	295
ADT312	1/15	6.0	408	3.0	390	2.4	492	5.4	342	3.0	354
ADT370	1/15	6.0	408	3.0	390	2.4	492	5.4	342	3.0	354

Performance Data

Model LET/LE Electric Defrost | 60 Hz

Model	Capacity		Fan Data			
	10°F TD -20°F SST	6°C TD -29°C SST	No.	CFM	m³H	
	BTUH	Watts				
6 Fins Per Inch	LET035	3,500	1,025	1	700	1,189
	LET040	4,000	1,170	1	700	1,189
	LET047	4,700	1,380	1	650	1,104
	LET065	6,500	1,900	2	1,400	2,379
	LET075	7,500	2,200	2	1,300	2,209
	LET090	9,000	2,640	2	1,300	2,209
	LET120	12,000	3,520	3	2,100	3,568
	LET140	14,000	4,100	3	1,950	3,313
	LET160	16,000	4,690	4	2,600	4,418
	LET180	18,000	5,280	4	2,600	4,418
	LET200	20,000	5,860	5	3,250	5,522
	LET240	24,000	7,030	6	3,900	6,627
	LET280	28,000	8,200	6	3,900	6,627
4 Fins Per Inch	LLE041	4,100	1,200	1	690	1,172
	LLE068	6,800	2,000	2	1,380	2,345
	LLE080	8,000	2,340	2	1,380	2,345
	LLE102	10,200	2,990	3	2,170	3,687
	LLE136	13,600	3,990	4	2,760	4,690
	LLE170	17,000	4,980	5	3,450	5,862
	LLE204	20,400	5,980	6	4,140	7,035
	LLE235	23,500	6,880	6	4,140	7,035

Capacity Correction Factors For Electric and Hot Gas Defrost Units

Saturated Suction Temperature °F	+20	-10	-20	-30
Saturated Suction Temperature °C	-7	-23	-29	-34
Multiply Capacity By	1.15	1.04	1.00	0.90

Model LET/LE Electric Defrost | 50 Hz †

Model	Capacity		Fan Data			
	10°F TD -20°F SST	6°C TD -29°C SST	No.	CFM	m³H	
	BTUH	Watts				
6 Fins Per Inch	LET035	3,325	974	1	630	1,070
	LET040	3,800	1,113	1	630	1,070
	LET047	4,465	1,308	1	586	995
	LET065	6,175	1,809	2	1,260	2,142
	LET075	7,125	2,087	2	1,170	1,989
	LET090	8,550	2,504	2	1,170	1,989
	LET120	11,400	3,339	3	1,891	3,213
	LET140	13,300	3,896	3	1,756	2,984
	LET160	15,200	4,452	4	2,341	3,978
	LET180	17,100	5,009	4	2,341	3,978
	LET200	19,000	5,565	5	2,927	4,973
	LET240	22,800	6,678	6	3,512	5,967
	LET280	26,600	7,791	6	3,512	5,967
4 Fins Per Inch	LLE041	3,895	1,141	1	621	1,056
	LLE068	6,460	1,892	2	1,243	2,111
	LLE080	7,600	2,226	2	1,243	2,111
	LLE102	9,690	2,838	3	1,954	3,320
	LLE136	12,920	3,784	4	2,485	4,223
	LLE170	16,150	4,731	5	3,107	5,279
	LLE204	19,380	5,677	6	3,728	6,334
	LLE235	22,325	6,539	6	3,728	6,334

† For EC motors, use 60 Hz capacity and airflow values (Units with EC motors operating at 50 Hz will not see a reduction in performance due to the electronic control of the motor)

Specifications

Model LET/LE Electric Defrost | 60 Hz

Model	HP	Shaded Pole Motor		PSC, PSC-TE Motor				EC Motor		Defrost Heaters				
		208-230/1/60		208-230/1/60		460/1/60		208-230/1/60		Watts	230/1/60	230/3/60	460/1/60	
		Amps	Watts	Amps	Watts	Amps	Watts	Amps	Watts		Total Amps			
6 Fins Per Inch	LET035	1/15	1.0	122	0.5	91	0.4	117	0.5	59	900	3.9	2.3	2.0
	LET040	1/15	1.0	122	0.5	91	0.4	117	0.5	59	900	3.9	2.3	2.0
	LET047	1/15	1.0	122	0.5	91	0.4	117	0.5	59	900	3.9	2.3	2.0
	LET065	1/15	2.0	244	1.0	182	0.8	234	1.0	118	1,800	7.8	4.5	3.9
	LET075	1/15	2.0	244	1.0	182	0.8	234	1.0	118	1,800	7.8	4.5	3.9
	LET090	1/15	2.0	244	1.0	182	0.8	234	1.0	118	1,800	7.8	4.5	3.9
	LET120	1/15	3.0	366	1.5	273	1.2	351	1.5	177	2,700	11.7	6.8	5.9
	LET140	1/15	3.0	366	1.5	273	1.2	351	1.5	177	2,700	11.7	6.8	5.9
	LET160	1/15	4.0	488	2.0	364	1.6	468	2.0	236	3,600	15.7	9.0	7.8
	LET180	1/15	4.0	488	2.0	364	1.6	468	2.0	236	3,600	15.7	9.0	7.8
	LET200	1/15	5.0	610	2.5	455	2.0	585	2.5	295	4,500	19.6	11.3	9.8
	LET240	1/15	6.0	732	3.0	546	2.4	702	3.0	354	5,400	23.5	13.6	11.7
LET280	1/15	6.0	732	3.0	546	2.4	702	3.0	354	5,400	23.5	13.6	11.7	
4 Fins Per Inch	LLE041	1/15	1.0	122	0.5	91	0.4	117	0.5	59	900	3.9	2.3	2.0
	LLE068	1/15	2.0	244	1.0	182	0.8	234	1.0	118	1,800	7.8	4.5	3.9
	LLE080	1/15	2.0	244	1.0	182	0.8	234	1.0	118	1,800	7.8	4.5	3.9
	LLE102	1/15	3.0	366	1.5	273	1.2	351	1.5	177	2,700	11.7	6.8	5.9
	LLE136	1/15	4.0	488	2.0	364	1.6	468	2.0	236	3,600	15.7	9.0	7.8
	LLE170	1/15	5.0	610	2.5	455	2.0	585	2.5	295	4,500	19.6	11.3	9.8
	LLE204	1/15	6.0	732	3.0	546	2.4	702	3.0	354	5,400	23.5	13.6	11.7
	LLE235	1/15	6.0	732	3.0	546	2.4	702	3.0	354	5,400	23.5	13.6	11.7

Model LET/LE Electric Defrost | 50 Hz

Model	HP	PSC Motor				EC Motor		Defrost Heaters				
		220/1/50		380/1/50		220/1/50		Watts	220/1/50	220/3/50	380/1/50	
		Amps	Watts	Amps	Watts	Amps	Watts		Total Amps			
6 Fins Per Inch	LET035	1/15	0.5	65	0.4	82	0.5	59	823	3.7	2.2	1.6
	LET040	1/15	0.5	65	0.4	82	0.5	59	823	3.7	2.2	1.6
	LET047	1/15	0.5	65	0.4	82	0.5	59	823	3.7	2.2	1.6
	LET065	1/15	1.0	130	0.8	164	1.0	118	1,647	7.5	4.3	3.2
	LET075	1/15	1.0	130	0.8	164	1.0	118	1,647	7.5	4.3	3.2
	LET090	1/15	1.0	130	0.8	164	1.0	118	1,647	7.5	4.3	3.2
	LET120	1/15	1.5	195	1.2	246	1.5	177	2,470	11.2	6.5	4.9
	LET140	1/15	1.5	195	1.2	246	1.5	177	2,470	11.2	6.5	4.9
	LET160	1/15	2.0	260	1.6	328	2.0	236	3,294	15.0	8.6	6.5
	LET180	1/15	2.0	260	1.6	328	2.0	236	3,294	15.0	8.6	6.5
	LET200	1/15	2.5	325	2.0	410	2.5	295	4,117	18.7	10.8	8.1
	LET240	1/15	3.0	390	2.4	492	3.0	354	4,941	22.5	13.0	9.7
LET280	1/15	3.0	390	2.4	492	3.0	354	4,941	22.5	13.0	9.7	
4 Fins Per Inch	LLE041	1/15	0.5	65	0.4	82	0.5	59	823	3.7	2.2	1.6
	LLE068	1/15	1.0	130	0.8	164	1.0	118	1,647	7.5	4.3	3.2
	LLE080	1/15	1.0	130	0.8	164	1.0	118	1,647	7.5	4.3	3.2
	LLE102	1/15	1.5	195	1.2	246	1.5	177	2,470	11.2	6.5	4.9
	LLE136	1/15	2.0	260	1.6	328	2.0	236	3,294	15.0	8.6	6.5
	LLE170	1/15	2.5	325	2.0	410	2.5	295	4,117	18.7	10.8	8.1
	LLE204	1/15	3.0	390	2.4	492	3.0	354	4,941	22.5	13.0	9.7
	LLE235	1/15	3.0	390	2.4	492	3.0	354	4,941	22.5	13.0	9.7

Performance Data

Model HGT Hot Gas Defrost | 60 Hz

	Model	Capacity		Fan Data		
		10°F TD -20°F SST	6°C TD -29°C SST	No.	CFM	m³H
		BTUH	Watts			
6 Fins Per Inch	HGT035	3,500	1,025	1	700	1,189
	HGT040	4,000	1,170	1	700	1,189
	HGT047	4,700	1,380	1	650	1,104
	HGT065	6,500	1,900	2	1,400	2,379
	HGT075	7,500	2,200	2	1,300	2,209
	HGT090	9,000	2,640	2	1,300	2,209
	HGT120	12,000	3,520	3	2,100	3,568
	HGT140	14,000	4,100	3	1,950	3,313
	HGT160	16,000	4,690	4	2,600	4,418
	HGT180	18,000	5,280	4	2,600	4,418
	HGT200	20,000	5,860	5	3,250	5,522
	HGT240	24,000	7,030	6	3,900	6,627
HGT280	28,000	8,200	6	3,900	6,627	
4 Fins Per Inch	HGT041	4,100	1,200	1	690	1,172
	HGT068	6,800	2,000	2	1,380	2,345
	HGT080	8,000	2,340	2	1,380	2,345
	HGT102	10,200	2,990	3	2,170	3,687
	HGT136	13,600	3,990	4	2,760	4,690
	HGT170	17,000	4,980	5	3,450	5,862
	HGT204	20,400	5,980	6	4,140	7,035
	HGT235	23,500	6,880	6	4,140	7,035

Capacity Correction Factors For Electric and Hot Gas Defrost Units

Saturated Suction Temperature °F	+20	-10	-20	-30
Saturated Suction Temperature °C	-7	-23	-29	-34
Multiply Capacity By	1.15	1.04	1.00	0.90

NOTE: When using the hot gas units with a hot gas loop drain pan on 0°F applications and below, an insulated drain pan is required.

Model HGT Hot Gas Defrost | 50 Hz †

	Model	Capacity		Fan Data		
		10°F TD -20°F SST	6°C TD -29°C SST	No.	CFM	m³H
		BTUH	Watts			
6 Fins Per Inch	HGT035	3,325	974	1	630	1,070
	HGT040	3,800	1,113	1	630	1,070
	HGT047	4,465	1,308	1	586	995
	HGT065	6,175	1,809	2	1,260	2,142
	HGT075	7,125	2,087	2	1,170	1,989
	HGT090	8,550	2,504	2	1,170	1,989
	HGT120	11,400	3,339	3	1,891	3,213
	HGT140	1,950	3,313	3	1,756	2,984
	HGT160	2,600	4,418	4	2,341	3,978
	HGT180	2,600	4,418	4	2,341	3,978
	HGT200	3,250	5,522	5	2,927	4,973
	HGT240	3,900	6,627	6	3,512	5,967
HGT280	3,900	6,627	6	3,512	5,967	
4 Fins Per Inch	HGT041	690	1,172	1	621	1,056
	HGT068	1,380	2,345	2	1,243	2,111
	HGT080	1,380	2,345	2	1,243	2,111
	HGT102	2,170	3,687	3	1,954	3,320
	HGT136	2,760	4,690	4	2,485	4,223
	HGT170	3,450	5,862	5	3,107	5,279
	HGT204	4,140	7,035	6	3,728	6,334
	HGT235	4,140	7,035	6	3,728	6,334

† For EC motors, use 60 Hz capacity and airflow values (Units with EC motors operating at 50 Hz will not see a reduction in performance due to the electronic control of the motor)

Specifications

Model HGT Hot Gas Defrost | 60 Hz

Model	HP	Shaded Pole Motor				PSC, PSC-TE Motor						EC Motor				Watts	Drain Pan Heaters*			
		115/1/60		208-230/1/60		115/1/60		208-230/1/60		460/1/60		115/1/60		208-230/1/60			115/1/60	230/1/60	460/1/60	
		Amps	Watts	Amps	Watts	Amps	Watts	Amps	Watts	Amps	Watts	Amps	Watts	Amps	Watts		Total Amps			
6 Fins Per Inch	HGT035	1/15	1.8	116	1.0	122	1.0	82	0.5	91	0.4	117	1.1	57	0.6	59	300	2.6	1.3	0.7
	HGT040	1/15	1.8	116	1.0	122	1.0	82	0.5	91	0.4	117	1.1	57	0.6	59	300	2.6	1.3	0.7
	HGT047	1/15	1.8	116	1.0	122	1.0	82	0.5	91	0.4	117	1.1	57	0.6	59	300	2.6	1.3	0.7
	HGT065	1/15	3.6	232	2.0	244	2.0	164	1.0	182	0.8	234	2.0	114	1.1	118	600	5.2	2.6	1.3
	HGT075	1/15	3.6	232	2.0	244	2.0	164	1.0	182	0.8	234	2.0	114	1.1	118	600	5.2	2.6	1.3
	HGT090	1/15	3.6	232	2.0	244	2.0	164	1.0	182	0.8	234	2.0	114	1.1	118	600	5.2	2.6	1.3
	HGT120	1/15	5.4	348	3.0	366	3.0	246	1.5	273	1.2	351	2.9	171	1.6	177	900	7.8	3.9	2.0
	HGT140	1/15	5.4	348	3.0	366	3.0	246	1.5	273	1.2	351	2.9	171	1.6	177	900	7.8	3.9	2.0
	HGT160	1/15	7.2	464	4.0	488	4.0	328	2.0	364	1.6	468	3.8	228	2.1	236	1,200	10.4	5.2	2.6
	HGT180	1/15	7.2	464	4.0	488	4.0	328	2.0	364	1.6	468	3.8	228	2.1	236	1,200	10.4	5.2	2.6
	HGT200	1/15	9.0	580	5.0	610	5.0	410	2.5	455	2.0	585	4.7	285	2.6	295	1,500	13.0	6.5	3.3
	HGT240	1/15	10.8	696	6.0	732	6.0	492	3.0	546	2.4	702	5.6	342	3.1	354	1,800	15.7	7.8	3.9
HGT280	1/15	10.8	696	6.0	732	6.0	492	3.0	546	2.4	702	5.6	342	3.1	354	1,800	15.7	7.8	3.9	
4 Fins Per Inch	HGT041	1/15	1.8	116	1.0	122	1.0	82	0.5	91	0.4	117	1.1	57	0.6	59	300	2.6	1.3	0.7
	HGT068	1/15	3.6	232	2.0	244	2.0	164	1.0	182	0.8	234	2.0	114	1.1	118	600	5.2	2.6	1.3
	HGT080	1/15	3.6	232	2.0	244	2.0	164	1.0	182	0.8	234	2.0	114	1.1	118	600	5.2	2.6	1.3
	HGT102	1/15	5.4	348	3.0	366	3.0	246	1.5	273	1.2	351	2.9	171	1.6	177	900	7.8	3.9	2.0
	HGT136	1/15	7.2	464	4.0	488	4.0	328	2.0	364	1.6	468	3.8	228	2.1	236	1,200	10.4	5.2	2.6
	HGT170	1/15	9.0	580	5.0	610	5.0	410	2.5	455	2.0	585	4.7	285	2.6	295	1,500	13.0	6.5	3.3
	HGT204	1/15	10.8	696	6.0	732	6.0	492	3.0	546	2.4	702	5.6	342	3.1	354	1,800	15.7	7.8	3.9
	HGT235	1/15	10.8	696	6.0	732	6.0	492	3.0	546	2.4	702	5.6	342	3.1	354	1,800	15.7	7.8	3.9

Model HGT Hot Gas Defrost | 50 Hz

Model	HP	PSC Motor						EC Motor				Watts	Drain Pan Heaters*			
		110/1/50		220/1/50		380/1/50		110/1/50		220/1/50			110/1/50	220/3/50	380/1/50	
		Amps	Watts	Amps	Watts	Amps	Watts	Amps	Watts	Amps	Watts		Total Amps			
6 Fins Per Inch	HGT035	1/15	1.0	68	0.5	65	0.4	82	1.1	57	0.6	59	275	2.5	1.3	0.6
	HGT040	1/15	1.0	68	0.5	65	0.4	82	1.1	57	0.6	59	275	2.5	1.3	0.6
	HGT047	1/15	1.0	68	0.5	65	0.4	82	1.1	57	0.6	59	275	2.5	1.3	0.6
	HGT065	1/15	2.0	136	1.0	130	0.8	164	2.0	114	1.1	118	549	5.0	2.5	1.1
	HGT075	1/15	2.0	136	1.0	130	0.8	164	2.0	114	1.1	118	549	5.0	2.5	1.1
	HGT090	1/15	2.0	136	1.0	130	0.8	164	2.0	114	1.1	118	549	5.0	2.5	1.1
	HGT120	1/15	3.0	204	1.5	195	1.2	246	2.9	171	1.6	177	823	7.5	3.7	1.6
	HGT140	1/15	3.0	204	1.5	195	1.2	246	2.9	171	1.6	177	823	7.5	3.7	1.6
	HGT160	1/15	4.0	272	2.0	260	1.6	328	3.8	228	2.1	236	1,098	10.0	5.0	2.2
	HGT180	1/15	4.0	272	2.0	260	1.6	328	3.8	228	2.1	236	1,098	10.0	5.0	2.2
	HGT200	1/15	5.0	340	2.5	325	2.0	410	4.7	285	2.6	295	1,372	12.5	6.2	2.7
	HGT240	1/15	6.0	408	3.0	390	2.4	492	5.6	342	3.1	354	1,649	15.0	7.5	3.2
HGT280	1/15	6.0	408	3.0	390	2.4	492	5.6	342	3.1	354	1,649	15.0	7.5	3.2	
4 Fins Per Inch	HGT041	1/15	1.0	68	0.5	65	0.4	82	1.1	57	0.6	59	275	2.5	1.3	0.6
	HGT068	1/15	2.0	136	1.0	130	0.8	164	2.0	114	1.1	118	549	5.0	2.5	1.1
	HGT080	1/15	2.0	136	1.0	130	0.8	164	2.0	114	1.1	118	549	5.0	2.5	1.1
	HGT102	1/15	3.0	204	1.5	195	1.2	246	2.9	171	1.6	177	823	7.5	3.7	1.6
	HGT136	1/15	4.0	272	2.0	260	1.6	328	3.8	228	2.1	236	1,098	10.0	5.0	2.2
	HGT170	1/15	5.0	340	2.5	325	2.0	410	4.7	285	2.6	295	1,372	12.5	6.2	2.7
	HGT204	1/15	6.0	408	3.0	390	2.4	492	5.6	342	3.1	354	1,649	15.0	7.5	3.2
	HGT235	1/15	6.0	408	3.0	390	2.4	492	5.6	342	3.1	354	1,649	15.0	7.5	3.2

* Optional with electric drain pan

Physical Data

Model ADT Air Defrost

Model	No. of Fans	Connections (in.)				Approx. Net Wt.	
		Coil Inlet OD	Suction ID	External Equalizer OD	Drain MPT	lbs.	kg
ADT040	1	1/2	5/8	1/4	3/4	28	13
ADT052	1	1/2	5/8	1/4	3/4	31	15
ADT065	1	1/2	7/8	1/4	3/4	34	16
ADT070	2	1/2	7/8	1/4	3/4	45	21
ADT090	2	1/2	7/8	1/4	3/4	48	22
ADT104	2	1/2	7/8	1/4	3/4	49	23
ADT120	2	1/2	7/8	1/4	3/4	51	24
ADT130	2	1/2	7/8	1/4	3/4	53	25
ADT140	3	1/2	7/8	1/4	3/4	63	29
ADT156	3	1/2	7/8	1/4	3/4	67	31
ADT180	3	1/2	7/8	1/4	3/4	69	32
ADT208	4	1/2	1-1/8	1/4	3/4	82	38
ADT260	5	1/2	1-1/8	1/4	3/4	103	47
ADT312	6	1/2	1-1/8	1/4	3/4	124	57
ADT370	6	1/2	1-3/8	1/4	3/4	127	58

Model LET/LE Electric Defrost

Model	No. of Fans	Connections (in.)				Approx. Net Wt.		
		Coil Inlet OD	Suction ID	External Equalizer OD	Drain MPT	lbs.	kg	
6 Fins Per Inch	LET035	1	1/2	5/8	1/4	3/4	24	11
	LET040	1	1/2	5/8	1/4	3/4	26	12
	LET047	1	1/2	5/8	1/4	3/4	29	14
	LET065	2	1/2	5/8	1/4	3/4	43	20
	LET075	2	1/2	5/8	1/4	3/4	45	21
	LET090	2	1/2	7/8	1/4	3/4	48	22
	LET120	3	1/2	7/8	1/4	3/4	60	28
	LET140	3	1/2	7/8	1/4	3/4	62	29
	LET160	4	1/2	1-1/8	1/4	3/4	81	37
	LET180	4	1/2	1-1/8	1/4	3/4	84	39
	LET200	5	1/2	1-1/8	1/4	3/4	101	46
	LET240	6	1/2	1-1/8	1/4	3/4	121	55
LET280	6	1/2	1-1/8	1/4	3/4	124	57	
4 Fins Per Inch	LLE041	1	1/2	5/8	1/4	3/4	28	13
	LLE068	2	1/2	7/8	1/4	3/4	44	21
	LLE080	2	1/2	7/8	1/4	3/4	47	22
	LLE102	3	1/2	7/8	1/4	3/4	59	27
	LLE136	4	1/2	1-1/8	1/4	3/4	80	37
	LLE170	5	1/2	1-1/8	1/4	3/4	100	46
	LLE204	6	1/2	1-1/8	1/4	3/4	120	55
	LLE235	6	1/2	1-1/8	1/4	3/4	123	56

Physical Data

Model HGT Hot Gas Defrost

Model	No. of Fans	Connections (in.)						Approx. Net Wt.		
		Coil Inlet ODF	Suction ID	External Equalizer OD	Drain MPT	Side Port OD	Hot Gas Pan Conns. OD	lbs.	kg	
6 Fins Per Inch	HGT035	1	5/8	5/8	1/4	3/4	3/8	5/8	26	12
	HGT040	1	5/8	5/8	1/4	3/4	3/8	5/8	28	13
	HGT047	1	5/8	5/8	1/4	3/4	3/8	5/8	31	15
	HGT065	2	5/8	5/8	1/4	3/4	3/8	5/8	45	21
	HGT075	2	5/8	7/8	1/4	3/4	3/8	5/8	47	22
	HGT090	2	7/8	7/8	1/4	3/4	3/8	5/8	50	23
	HGT120	3	7/8	7/8	1/4	3/4	3/8	5/8	62	29
	HGT140	3	7/8	7/8	1/4	3/4	3/8	5/8	64	30
	HGT160	4	7/8	1-1/8	1/4	3/4	3/8	5/8	83	38
	HGT180	4	1-1/8	1-1/8	1/4	3/4	3/8	5/8	86	40
	HGT200	5	1-1/8	1-1/8	1/4	3/4	3/8	5/8	103	47
	HGT240	6	1-1/8	1-1/8	1/4	3/4	3/8	5/8	123	56
HGT280	6	1-1/8	1-1/8	1/4	3/4	3/8	5/8	126	57	
4 Fins Per Inch	HGT041	1	5/8	5/8	1/4	3/4	3/8	5/8	30	14
	HGT068	2	5/8	7/8	1/4	3/4	3/8	5/8	46	21
	HGT080	2	5/8	7/8	1/4	3/4	3/8	5/8	49	23
	HGT102	3	7/8	7/8	1/4	3/4	3/8	5/8	61	28
	HGT136	4	7/8	1-1/8	1/4	3/4	3/8	5/8	82	38
	HGT170	5	7/8	1-1/8	1/4	3/4	3/8	5/8	102	47
	HGT204	6	7/8	1-1/8	1/4	3/4	3/8	5/8	122	56
HGT235	6	1-1/8	1-1/8	1/4	3/4	3/8	5/8	125	57	

The standard design for the Bohn Low Profile Evaporator incorporates a hot gas loop in the drain pan. Utilizing a hot gas loop is ideal for hot gas defrost applications where high temperature gas can be maintained to defrost both the evaporator drain pan and coil.

For applications where cooler (lower) temperature hot gas is used for defrosting, Bohn offers optional electric heater elements in the drain pan to ensure quick and efficient defrost of the drain pan allowing condensate to drain quickly, saving the hot gas for efficient evaporator coil defrost.

If the optional electric heating element drain pan is preferred, please specify when ordering, there is no additional charge.

Dimensional Data

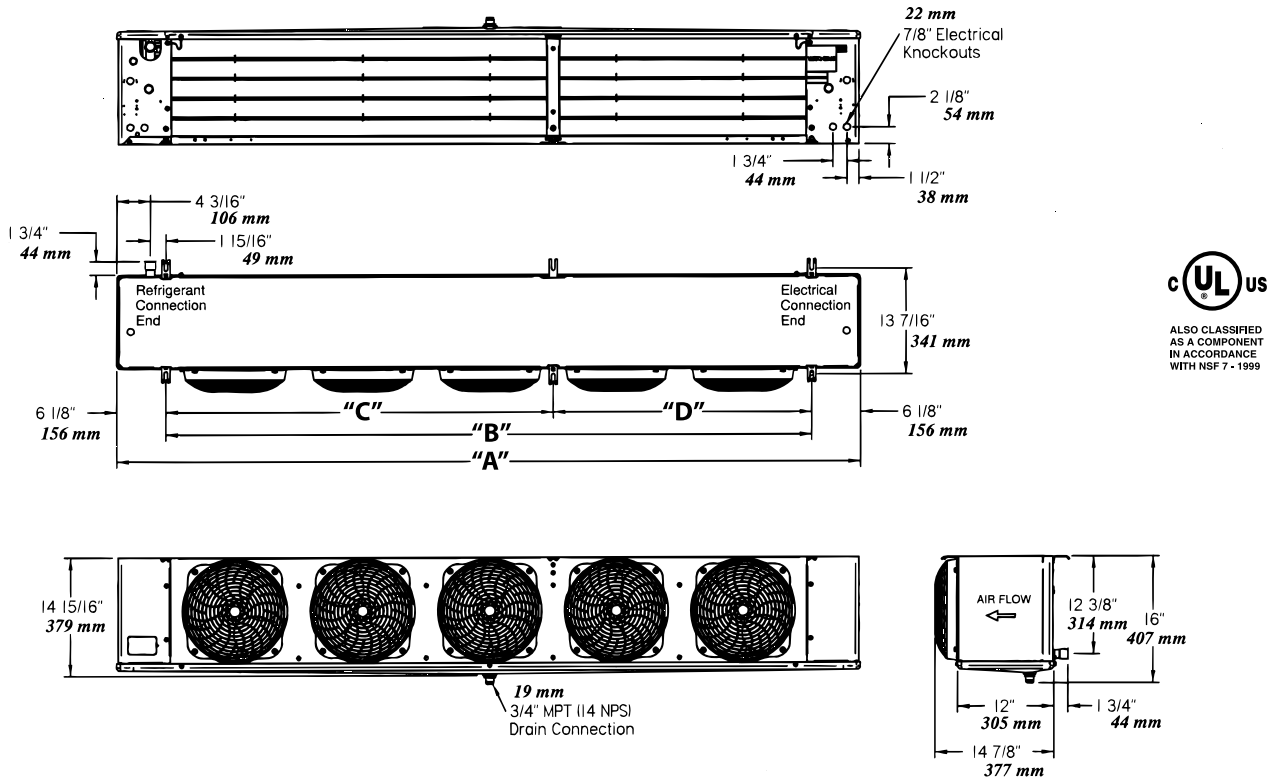

Dimensional Data For All Models

Air Defrost Model	Electric and Hot Gas Defrost Model		No. of Fans	Dimensions							
				A		B		C		D	
				in.	mm	in.	mm	in.	mm	in.	mm
040	035	-	1	29.50	749.3	17.25	438.1	-	-	-	-
052	040	-	1	29.50	749.3	17.25	438.1	-	-	-	-
065	047	041	1	29.50	749.3	17.25	438.1	-	-	-	-
070	-	-	2	45.50	1,155.7	33.25	845	-	-	-	-
090	065	-	2	45.50	1,155.7	33.25	845	-	-	-	-
104	-	-	2	45.50	1,155.7	33.25	845	-	-	-	-
120	075	068	2	45.50	1,155.7	33.25	845	-	-	-	-
130	090	080	2	45.50	1,155.7	33.25	845	-	-	-	-
140	120	102	3	61.50	1,562.1	49.25	1,251	-	-	-	-
156	-	-	3	61.50	1,562.1	49.25	1,251	-	-	-	-
180	140	-	3	61.50	1,562.1	49.25	1,251	-	-	-	-
208	160	-	4	77.50	1,968.5	65.25	1,657	-	-	-	-
-	180	136	4	77.50	1,968.5	65.25	1,657	-	-	-	-
260	200	170	5	93.50	2,374.9	81.25	2,064	48.63	1,235.1	32.63	828.7
312	240	204	6	109.50	2,781.3	97.25	2,470	48.63	1,235.1	48.63	1,235.1
370	280	235	6	109.50	2,781.3	97.25	2,470	48.63	1,235.1	48.63	1,235.1

NOTE: Hanger brackets will accept 3/8" / 9.5 mm hanger rods.

Hot Gas Reverse Cycle Kits

	Shipped-loose			Factory-installed		
	TXV Bypass Assembly Kits			TXV Bypass Assembly Kits		
HGT 6 FPI	SQE/SBF	EG	HFESC	SQE/SBF	EG	HFESC
035-075	50169210	50169213	50169216	52733701	52733704	52733707
090-160	50169211	50169214	50169217	52733702	52733705	52733708
180-280	50169212	50169215	50169218	52733703	52733706	52733709
HGT 4 FPI						
041-080	50169210	50169213	50169216	52733701	52733704	52733707
102-204	50169211	50169214	50169217	52733702	52733705	52733708
235	50169212	50169215	50169218	52733703	52733706	52733709

	Shipped-loose		Factory-installed	
	Drain Pan Loop Check Valve Kit	Suction Line Check Valve Kit	Drain Pan Loop Check Valve Kit	Suction Line Check Valve Kit
HGT 6 FPI				
035-065	50169304	50169604	52733601	52733801
075-140	50169305	50169605	52733602	52733802
160-280	50169306	50169606	52733603	52733803
HGT 4 FPI				
041	50169304	50169604	52733601	52733801
068-102	50169305	50169605	52733602	52733802
136-235	50169306	50169606	52733603	52733803

Recommendation is that both check valve kits are ordered: (For hot gas models with the hot gas loop drain pan ONLY)

NOTE: The drain pan check valve kit can be ordered as an independent item. But the suction line check valve kit must be ordered with the drain pan check valve kit in order to complete the piping.

NOTE: When using the hot gas units with a hot gas loop drain pan on 0°F applications and below, an insulated drain pan is required.

The hot gas unit coolers can be used in reverse cycle hot gas defrost systems using multiple evaporators connected to one condensing unit. Generally, not more than one-third of the system defrosts at one time.

During the reverse cycle defrost, the reversing valve; located in the compressor discharge line, diverts hot gas through the suction line to the evaporator. See piping view in Figure 1. The suction line check valve directs the hot gas through the drain pan loop which prevents condensate in the pan from freezing. The hot gas exits the loop at the pan loop outlet header and enters the evaporator through the check valve assembly. As the hot gas defrosts the coil, heat is removed from the hot gas and eventually it condenses into a liquid and exits the coil at the distributor sideport. The liquid then flows through the check valve of the thermostatic expansion valve bypass assembly, around the thermostatic expansion valve, and into the system liquid line. The liquid refrigerant then feeds other evaporators on the cooling cycle, evaporates, and returns to the compressor through their suction lines.

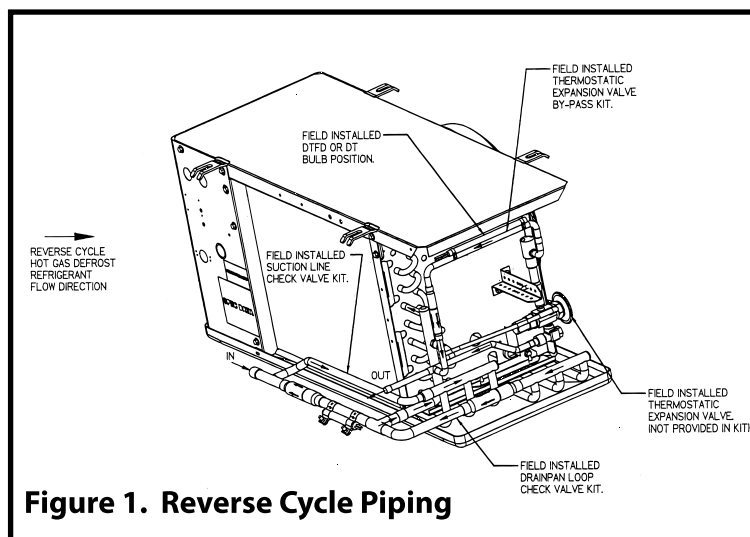

Figure 1. Reverse Cycle Piping

Hot Gas Reverse Cycle Kits (cont.)

In the refrigeration cycle, the thermostatic expansion valve bypass assembly check valve only allows refrigerant flow through the thermostatic expansion valve and into the evaporator coil. As the refrigerant vapor exits the coil at the suction line, the check valve of the drain pan loop check valve assembly prevents the refrigerant vapor flow through the drain pan loop.

Factory engineered assemblies (kits) are available for both shipped-loose and factory-installed at an additional cost to complete the reverse cycle piping and components. The suction line check valve assembly includes the suction line check valve and the piping for both the suction line and the connection to the drain pan loop inlet header. In order for the suction line check valve assembly to be mounted, the drain pan loop check valve assembly must be used. The drain pan loop check valve assembly includes the check valve, suction line tee and a bent pipe. The thermostatic expansion valve bypass assembly option includes the check valve, tee and necessary piping. In order for the thermostatic expansion valve bypass assembly option to be complete, a thermostatic expansion valve must be selected by the sales engineer. The thermostatic expansion valve bypass assembly option is dependent on the body style of the thermostatic expansion valves which includes the Sporlan SQE, SBF, EG and the Alco HFESC body styles. The factory-installed thermostatic expansion valve bypass assembly option must have the thermostatic expansion valve selection included on the order for the hot gas unit cooler.

To increase the efficiency, higher performance and greater system protection, a heat exchanger may be beneficial to the system. In order to use a heat exchanger, the thermostatic expansion valve bypass assembly option must be modified. See the piping view in Figure 2. The modification includes rerouting the pipe from the thermostatic expansion valve bypass check valve to the inlet connection of the liquid line to the heat exchanger. A pipe needs to be routed from the liquid line outlet connection of the heat exchanger to the inlet connection of the thermostatic expansion valve.

The electrical control option includes an adjustable defrost termination and fan delay control (DTFD) which is standard. For an additional cost, an optional (2) control electrical system is available with one adjustable control for defrost termination (DT) and one fixed control for the fan delay (FD). For both the DTFD and DT adjustable controls, the remote bulb position is with the bulb strapped to the piping of the thermostatic expansion valve bypass assembly option between the distributor sideport and the check valve. When the thermostatic expansion valve bypass assembly is shipped-loose, the installer will need to position the remote bulb. When the thermostatic expansion valve bypass assembly is factory-installed, the remote bulb should already be properly installed.

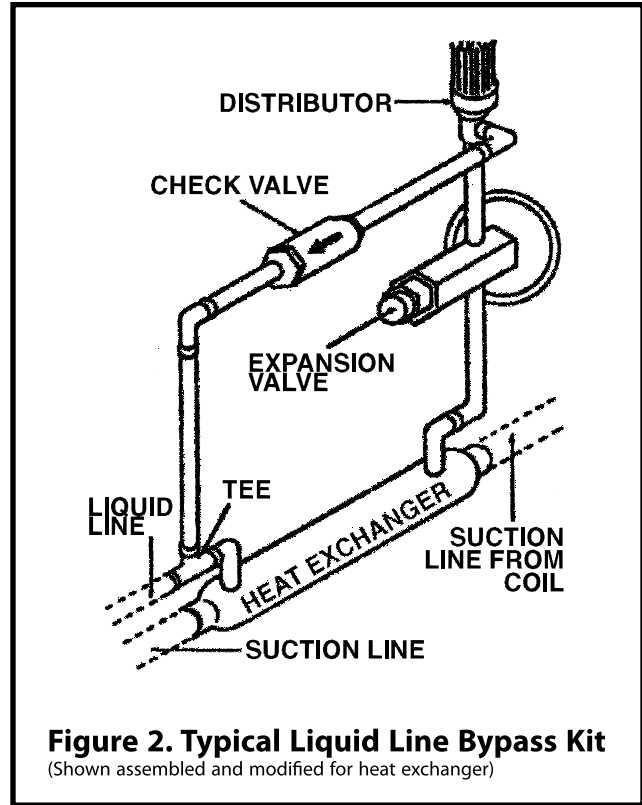

Figure 2. Typical Liquid Line Bypass Kit
(Shown assembled and modified for heat exchanger)

3-Pipe Hot Gas Defrost

The hot gas defrost unit cooler conforms to the standard 3-pipe hot gas system using a check valve assembly, an electrical control to terminate the defrost, and a hot gas solenoid valve. The check valve assembly transports the hot gas between the drain pan loop and the sideport distributor of the coil. The check valve assembly kit is available for shipped-loose or factory-installed for an additional cost.

The electrical control option includes an adjustable defrost termination and fan delay control (DTFD) which is standard. An optional (2) control electrical system is available with one adjustable control for defrost termination (DT) and one fixed control for the fan delay (FD) for an additional cost. For both the DTFD and DT adjustable controls, the remote bulb position is with the bulb strapped to the suction line to insure a complete defrost. The remote bulb is positioned by the installer. The hot gas solenoid valve must be ordered separately and will be shipped-loose. The thermostatic expansion valve could be ordered separately and shipped-loose or the thermostatic expansion valve could be factory-installed with a liquid line for an additional cost.

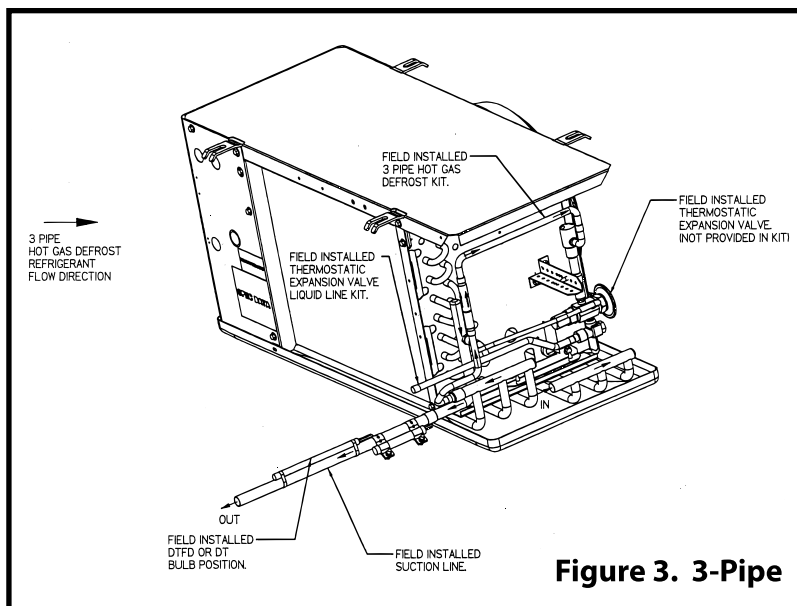

Figure 3. 3-Pipe

The liquid line is designed for the body styles of the Sporlan SQE, SBF, EG and the Alco HFESC thermostatic expansion valves. The thermostatic expansion valve needs to be selected by the sales engineer. In a typical 3-pipe, multiple evaporator system, the compressor discharge defrosts the evaporator. The liquid/vapor mixture of refrigerant after defrost, however, returns to the common suction line of the system. In order to provide sufficient re-evaporation of the liquid vapor mixture and sufficient heat for defrost, no more than one-third of the system should be defrosted at one time. Some means of control in the 3-pipe hot gas system should be supplied to regulate the large amount of liquid returning to the compressor, refrigerant slugging can otherwise damage the compressor.

	Shipped-loose			Factory-installed		
	TXV Liquid Line			TXV Liquid Line		
HGT 6 FPI	SQE/SBF	EG	HFESC	SQE/SBF	EG	HFESC
035-075	50169410	50169413	50169416	52733901	52733904	52733907
090-160	50169411	50169414	50169417	52733902	52733905	52733908
180-280	50169412	50169415	50169418	52733903	52733906	52733909
HGT 4 FPI						
041-080	50169410	50169413	50169416	52733901	52733904	52733907
102-204	50169411	50169414	50169417	52733902	52733905	52733908
235	50169412	50169415	50169418	52733903	52733906	52733909

For hot gas models with the hot gas loop drain pan only

When using the hot gas units with a hot gas loop drain pan on 0°F applications and below, an insulated drain pan is required.

	Shipped-loose	Factory-installed
	Drain Pan Loop Check Valve Kit	Drain Pan Loop Check Valve Kit
HGT 6 FPI		
035-075	50169504	52739601
090-160	50169505	52739602
180-280	50169506	52739603
HGT 4 FPI		
041-080	50169504	52739601
102-204	50169505	52739602
235	50169506	52739603

Replacement Parts



Right source. Right parts. Right now.

InterLink™ is your link to a complete line of dependable and certified commercial refrigeration parts, accessories and innovative electronic controls for all Bohn equipment. At InterLink, we provide our wholesalers with a comprehensive selection of product solutions and innovative technologies for the installed customer base. And every product is built to ensure the same high performance standards with which all Heatcraft Refrigeration Products (HRP) brands are built — backed by a dedicated team to serve every customer need, delivering at the best lead times in the industry.

Dependable. Versatile. Courteous.

Finally, one simple source for all your replacement needs from a name you can trust.

For parts, please contact (800) 686-7278 or visit www.interlinkparts.com.

No. Fans	Air Defrost 6 FPI	Electric & Hot Gas Defrost	
		6 FPI	4 FPI
1	040-065	035-047	041
2	070-130	065-090	068-080
3	140-180	120-140	102
4	208	160-180	136
5	260	200	170
6	312-370	240-280	204-235

Motor/Fan Blade/Fan Guards

Part #	Description	No. Fans
25300101	Motor 115/1/60 Shaded Pole	1 - 6
25300201	Motor 208-230/1/60 Shaded Pole	1 - 6
25309501	Motor 115/1/60/50 Totally Enclosed PSC/PSC	1 - 6
25309601	Motor 208-230/1/60/50 Totally Enclosed PSC	1 - 6
25309701	Motor 460/1/60/50 Totally Enclosed PSC	1 - 6
25309801	Motor 208-230/1/60/50 PSC	1 - 6
25308701	Motor 460/1/60/50 PSC	1 - 6
25317701	Motor 208-230/1/60 EC	1 - 6
25317801	Motor 115/1/60 EC	1 - 6
5140C	Fan Blade	1 - 6
37000701	Fan Guard - Molded	1 - 6
37000601	Fan Guard - Wire	1 - 6
23104901	Motor Mount used with 115 & 230V motors	1 - 6
23103301	Motor Mount used with 460V motors	1 - 6

Cabinet Components

Part #	Description	No. Fans
40480101	Drain Pan Air & Hot Gas Defrost	1
40480201	Drain Pan Air & Hot Gas Defrost	2
40480301	Drain Pan Air & Hot Gas Defrost	3
40480401	Drain Pan Air & Hot Gas Defrost	4
40480501	Drain Pan Air & Hot Gas Defrost	5
40480601	Drain Pan Air & Hot Gas Defrost	6
40480103	Drain Pan Electric Defrost	1
40480205	Drain Pan Electric Defrost	2
40480305	Drain Pan Electric Defrost	3
40480403	Drain Pan Electric Defrost	4
40480503	Drain Pan Electric Defrost	5
40480603	Drain Pan Electric Defrost	6
40880801	Access Panel - Elect.	1 - 6
40880701	Access Panel - Refrig.	1 - 6
40880901	Back Panel - Refrig.	1 - 6
40881001	Back Panel - Elect.	1 - 6
40881201	End Panel - Hot Gas Refrig.	1 - 6

Hot Gas Defrost - Electric Drain Pan Option Drain Pan Heater (1 per unit)

Part #	Description	Voltage	No. Fans
24752101	300 W	115/1/60	1
24752102	600 W	115/1/60	2
24752103	900 W	115/1/60	3
24752104	1200 W	115/1/60	4
24752105	1500 W	115/1/60	5
24752106	1800 W	115/1/60	6
24752201	300 W	208-230/1/60	1
24752202	600 W	208-230/1/60	2
24752203	900 W	208-230/1/60	3
24752204	1200 W	208-230/1/60	4
24752205	1500 W	208-230/1/60	5
24752206	1800 W	208-230/1/60	6
24752301	300 W	460/1/60	1
24752302	600 W	460/1/60	2
24752303	900 W	460/1/60	3
24752304	1200 W	460/1/60	4
24752305	1500 W	460/1/60	5
24752306	1800 W	460/1/60	6

Electric Defrost

Part #	Description	Voltage	No. Fans
Coil Heater			
24752001	300 W	208-230/1/60	1
24752002	600 W	208-230/1/60	2
24752003	900 W	208-230/1/60	3
24752004	1200 W	208-230/1/60	4
24752005	1500 W	208-230/1/60	5
24752006	1800 W	208-230/1/60	6
Bottom Coil Heater			
24752401	150 W	208-230/1/60	1
24752402	300 W	208-230/1/60	2
24752403	450 W	208-230/1/60	3
24752404	600 W	208-230/1/60	4
24752405	750 W	208-230/1/60	5
24752406	900 W	208-230/1/60	6
Drain Pan Heater			
24752501	150 W	208-230/1/60	1
24752502	300 W	208-230/1/60	2
24752503	450 W	208-230/1/60	3
24752504	600 W	208-230/1/60	4
24752505	750 W	208-230/1/60	5
24752506	900 W	208-230/1/60	6

Electrical Components

Part #	Description	No. Fans
22512601	Terminal Strip	1 - 6
5709L	Defrost Termination/Fan Delay — Klixon type	1 - 6
4267W	Defrost Termination/Fan Delay — Adjustable type	1 - 6
2891040	Room Thermostat	1 - 6
5708L	Heater Safety — Klixon type	1 - 6

Drain Fittings

Part #	Description	No. Fans
26925101	Drain Fitting Kit	1 - 6

Standard Nozzle Selection

Model ADT Air Defrost

Model	No. of Fans	Distributor Tube (in.)		No. of Circuits	R-404A	R-22
		OD	Length			
ADT040	1	3/16	15	1	-	-
ADT052	1	3/16	15	1	-	-
ADT065	1	3/16	15	2	L-1/2	L-1/3
ADT070	2	3/16	15	2	L-1/2	L-1/3
ADT090	2	3/16	15	3	L-3/4	L-1/2
ADT104	2	3/16	15	3	L-3/4	L-1/2
ADT120	2	3/16	15	3	L-1	L-3/4
ADT130	2	3/16	15	4	L-1	L-3/4
ADT140	3	3/16	15	4	L-1	L-3/4
ADT156	3	3/16	15	5	L-1-1/2	L-1
ADT180	3	3/16	15	5	L-1-1/2	L-1
ADT208	4	3/16	15	5	L-1-1/2	L-1
ADT260	5	3/16	15	9	L-2	L-1-1/2
ADT312	6	3/16	15	9	L-2-1/2	L-2
ADT370	6	3/16	15	10	L-3	L-2

Model LET/LLE Electric Defrost

Model	No. of Fans	Distributor Tube (in.)		No. of Circuits	Low Temp. -30°F to 0°F SST -34°C to -18°C SST		Medium Temp. 10°F to 25°F SST -12°C to -4°C SST		
		OD	Length		R-404A	R-22	R-404A	R-22	
6 Fins Per Inch	LET035	1	3/16	15	2	L-1/2	L-1/4	L-1/3	L-1/4
	LET040	1	3/16	15	2	L-1/2	L-1/4	L-1/3	L-1/4
	LET047	1	3/16	15	2	L-1/2	L-1/3	L-1/3	L-1/3
	LET065	2	3/16	15	4	L-3/4	L-1/2	L-1/2	L-1/2
	LET075	2	3/16	15	4	L-1	L-3/4	L-3/4	L-1/2
	LET090	2	3/16	15	5	L-1	L-3/4	L-3/4	L-1/2
	LET120	3	3/16	15	5	L-1-1/2	L-1	L-1	L-3/4
	LET140	3	3/16	15	6	L-1-1/2	L-1	L-1-1/2	L-1
	LET160	4	3/16	15	8	L-2	L-1	L-1-1/2	L-1
	LET180	4	3/16	15	10	L-2	L-1-1/2	L-1-1/2	L-1
	LET200	5	3/16	15	9	L-2-1/2	L-1-1/2	L-2	L-1-1/2
LET240	6	3/16	15	9	L-2-1/2	L-2	L-2	L-1-1/2	
LET280	6	3/16	15	10	L-3	L-2	L-2-1/2	L-2	
4 Fins Per Inch	LLE041	1	3/16	15	2	L-1/2	L-1/3	L-1/3	L-1/4
	LLE068	2	3/16	15	4	L-3/4	L-1/2	L-1/2	L-1/3
	LLE080	2	3/16	15	4	L-1	L-3/4	L-3/4	L-1/2
	LLE102	3	3/16	15	5	L-1	L-3/4	L-3/4	L-3/4
	LLE136	4	3/16	15	8	L-1-1/2	L-1	L-1	L-3/4
	LLE170	5	3/16	15	8	L-2	L-1-1/2	L-1-1/2	L-1
	LLE204	6	3/16	15	8	L-2-1/2	L-1-1/2	L-2	L-1-1/2
	LLE235	6	3/16	15	10	L-2-1/2	L-2	L-2	L-1-1/2

Model HGT Hot Gas Defrost

Model	No. of Fans	Distributor Tube (in.)		No. of Circuits	Low Temp. -30°F to 0°F SST -34°C to -18°C SST		Medium Temp. 10°F to 25°F SST -12°C to -4°C SST		
		OD	Length		R-404A	R-22	R-404A	R-22	
6 Fins Per Inch	HGT035	1	1/4	15	2	J-1/2	J-1/4	J-1/3	J-1/4
	HGT040	1	1/4	15	2	J-1/2	J-1/3	J-1/3	J-1/4
	HGT047	1	1/4	15	2	J-3/4	J-1/3	J-1/2	J-1/4
	HGT065	2	1/4	15	4	J-1	J-1/2	J-3/4	J-1/3
	HGT075	2	1/4	15	4	J-1	J-3/4	J-3/4	J-1/2
	HGT090	2	1/4	15	5	G-1-1/2	G-3/4	G-3/4	G-1/2
	HGT120	3	1/4	15	5	G-1-1/2	G-1	G-1	G-3/4
	HGT140	3	1/4	15	6	G-2	G-1	G-1-1/2	G-1
	HGT160	4	1/4	15	8	G-2	G-1-1/2	G-1-1/2	G-1
	HGT180	4	1/4	15	10	E-2-1/2	E-1-1/2	E-1-1/2	E-1
	HGT200	5	1/4	15	9	E-2-1/2	E-2	E-2	E-1-1/2
HGT240	6	1/4	15	9	E-3	E-2	E-2	E-1-1/2	
HGT280	6	1/4	15	10	E-4	E-2-1/2	E-2-1/2	E-2	
4 Fins Per Inch	HGT041	1	1/4	15	2	J-1/2	J-1/3	J-1/3	J-1/4
	HGT068	2	1/4	15	4	J-1	J-1/2	J-3/4	J-1/2
	HGT080	2	1/4	15	4	J-1	J-3/4	J-3/4	J-1/2
	HGT102	3	1/4	15	5	G-1-1/2	G-3/4	G-1	G-3/4
	HGT136	4	1/4	15	8	G-2	G-1	G-1-1/2	G-1
	HGT170	5	1/4	15	8	G-2	G-1-1/2	G-1-1/2	G-1
	HGT204	6	1/4	15	8	G-2-1/2	G-2	G-2	G-1-1/2
	HGT235	6	1/4	15	10	E-3	E-2	E-2	E-1-1/2

Notes

Notes



For more information on Bohn refrigeration products, contact your sales representative or visit us at www.thecoldstandard.com.



A Brand of Heatcraft Refrigeration Products LLC
2175 West Park Place Blvd. • Stone Mountain, GA • 30087
800.537.7775 • FAX 770.465.5990

www.thecoldstandard.com

Since product improvement is a continuing effort, we reserve the right to make changes in specifications without notice.

BN-LOPTB-0408 | Version 000