

McDaniel Metals

281-987-8400 • 281-987-9494 (fax)
1318 Buschong, Houston, TX 77039
www.mcdanielmetals.com

DDNECNJPGMM

DOWNFLOW JADE ECONOMIZER
FITS DAIKIN DPG13M AND DPD13M
SINGLE PHASE MEDIUM CHASSIS



ECONOMIZER 101

Economizers are designed to provide “free” air conditioning when outside conditions are appropriate. When the outside air is cool and dry enough, the economizer automatically opens to introduce the cool air to the interior space, thereby eliminating the need to run the air conditioning compressor.

If the outside air becomes too warm or humid, the economizer automatically closes the fresh air damper and the compressor engages to begin cooling the space mechanically.

If a two stage thermostat is used it is possible to use a combination of economizer and mechanical cooling to condition the space.

The economizer can also be set to allow a minimum amount of fresh air to enter the space when the equipment’s indoor blower is operating.

Economizers are valuable tools to enhance indoor air quality, save energy and prolong the life of the air conditioning equipment.

SEQUENCE OF OPERATION

This sequence assumes employment of a single enthalpy economizer using a two stage thermostat.

1. A call for cooling comes from room thermostat.
2. The enthalpy sensor determines if the atmospheric conditions are conducive for using outside air for cooling. If YES, go to step 3. If NO, or if outdoor air temperature rises above enthalpy set point, go to step 4.
3. The outside air dampers open and modulate to maintain a mixed air temperature (outside air + indoor air) of 53 degrees F. If the outdoor air is insufficient to satisfy the thermostat alone and a second stage of cooling is required, the compressor starts and works in conjunction with the economizer to cool the space. (Go to step 5.)
4. Outdoor air dampers open to minimum position and the compressor engages to provide mechanical cooling.
5. When the thermostat is satisfied the outside air dampers return to a closed position.

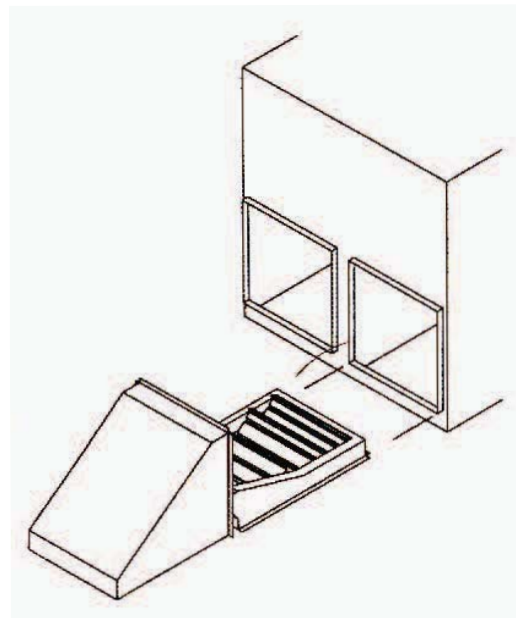

Figure 1

INSTALLATION

1. Open carton and inspect contents for shortages and damage.
2. Remove large blower access panel from package unit.
3. Remove the horizontal duct opening cover.
4. Remove the downflow return air panel inside of the unit.
5. Slide the damper/hood assembly into the horizontal opening until the return air dampers are above the downflow return air opening and the fresh air hood is against the side of the unit. (Figure 1)
6. Attach the hood to the side of the unit using sheet metal screws.

NOTE: Ensure that the wires do not interfere with either the fresh air or return air damper operation. The wires should not be pinched between the fresh air hood and the unit or the return air dampers and the base pan.

7. Disconnect the jumper plug from the unit and attach the male molex plug from the economizer.
8. Feed the pink mixed air sensor wires to the evaporator section of the unit and secure using the bracket provide. Connect the wires to the sensor. (Figure 2)
9. Seal connection between the fresh air hood and unit until water tight.
10. Determine the proper enthalpy setting using enclosed control documentation. Factory setting is ES4.
11. Determine the minimum position setting using the minimum set point equation on page two.
12. Replace the blower access panel.

CONTENTS

1	Damper rack w/ economizer controls
1	Installation guide
1	Honeywell control literature
1	C7400 mixed air sensor and bracket
1	Jumper harness

ACCESSORIES / CAPABILITIES

Dual Enthalpy - Requires an additional C7400 enthalpy control installed in the return air duct.

Demand Control Ventilation - Requires a CO2 sensor.

Remote Minimum Positioner - For applications requiring minimum position adjustments inside the conditioned space.

Important Notes

Please see enclosed brochure for Honeywell component trouble shooting instructions.

A two stage thermostat is recommended with this accessory.

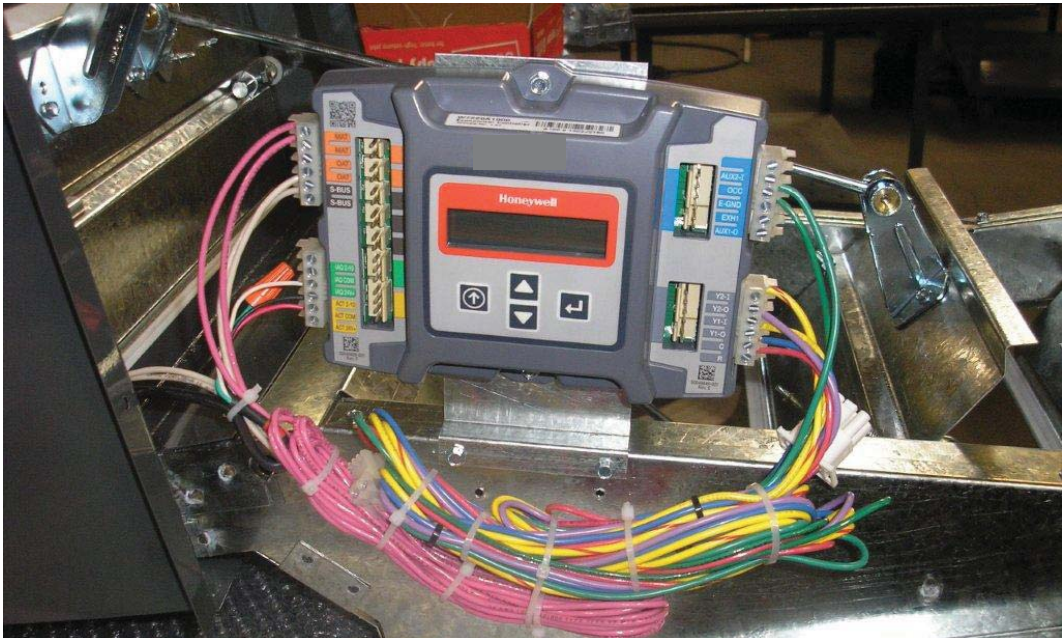

Figure 2

MINIMUM SET POINT EQUATION

(To X OA) + (Tr X RA) = Tm
To = Outdoor air temperature
OA= Percent of outdoor air
Tr = Return air temperature
RA= Percent of return air
Tm= Resulting mixed air temperature

Example:
 Fresh air required is 10% outdoor air.
 Outdoor air temperature is 60 degrees F.
 Return air temperature is 75 degrees F.
 $(0.1 \times 60) + (0.9 \times 75) =$
 $6.0 + 67.5 = 73.5$
 Mixed air temperature will be 73.5 degrees F when the OA is 60 degrees F and the RA is 75 degrees F with 10% outdoor air.



36240/ 3672B ECONOMIZER

3-6 TON

GROUND LUG
GROUND

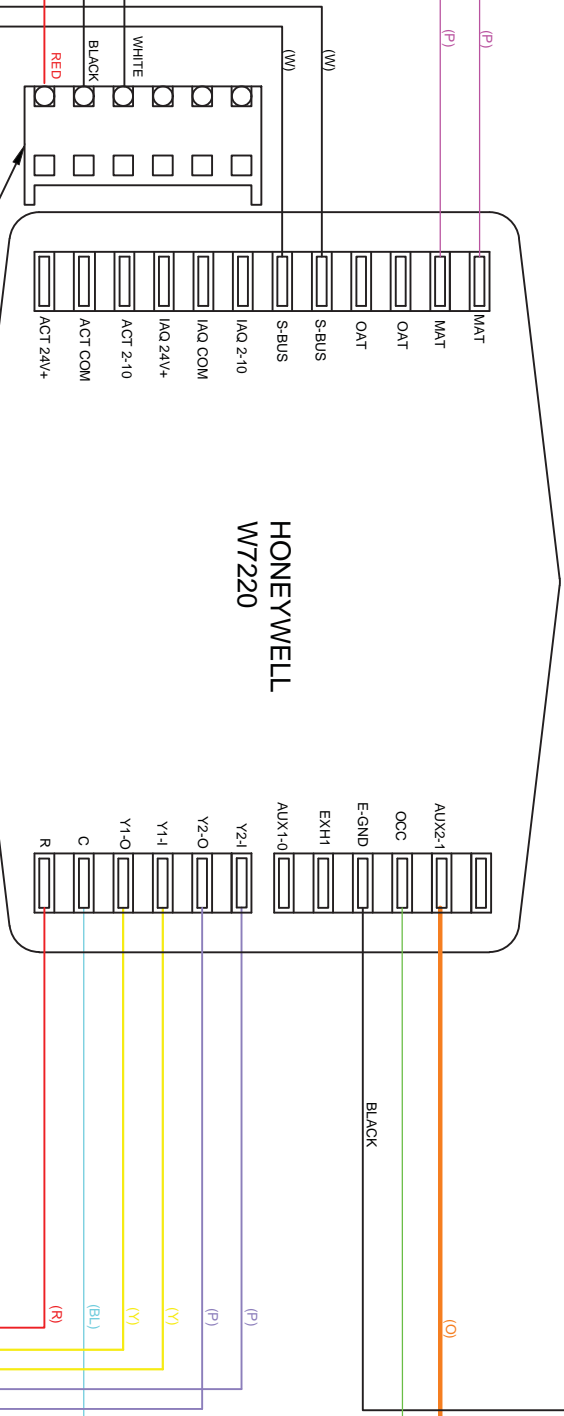
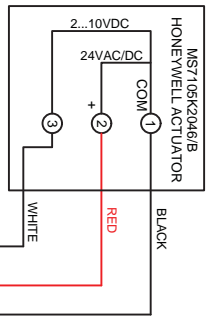

- COLOR CODES FOR 9 PIN PLUG
- 1 (Y) YELLOW
 - 2 (P) PURPLE
 - 3 (P) PURPLE
 - 4 (Y) YELLOW
 - 5 (BL) BLUE
 - 6 (G) GREEN
 - 8 (O) ORANGE
 - 9 (R) RED

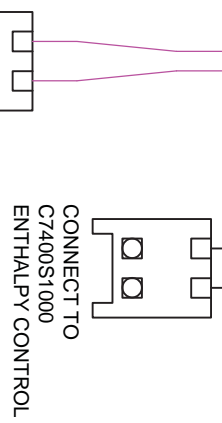
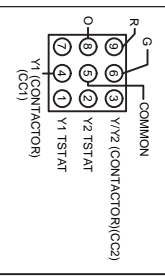

MOLEX 3597706**
50048926-002

