

# Standard Circulating Pumps

Product review: Wilo-Star/Star S

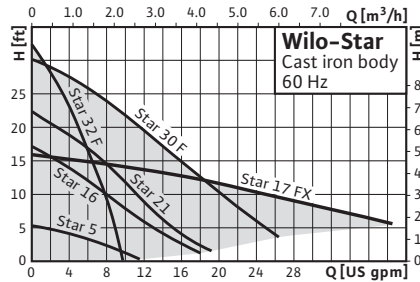

## Range: Wilo-Star



### > Single head pumps:

- Wet rotor circulation pump, with flanged or union connections

### > Applications:

- Cast iron body for hot-water heating systems of all kinds, industrial circulation systems, cold-water systems and air-conditioning systems
- Bronze body for domestic hot water applications

### > Special features/product advantages:

- Suitable for any installation position with horizontal shaft; terminal box in 3-6-9-12 o'clock position

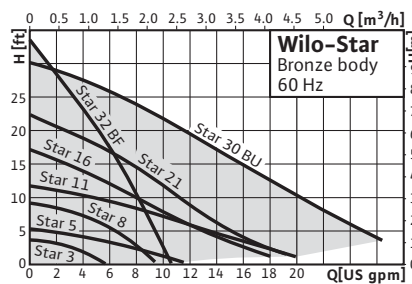

## Range: Wilo-Star S

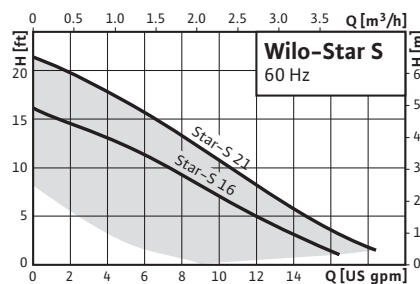

### > Single head pumps:

- Wet rotor circulation pump, with flanged or union connections. Preselectable speeds to adjust the capacity on "S" versions

### > Applications:

- Cast iron body for hot-water heating systems of all kinds, industrial circulation systems, cold-water systems and air-conditioning systems
- Bronze body for domestic hot water applications

### > Special features/product advantages:

- Suitable for any installation position with horizontal shaft; terminal box in 3-6-9-12 o'clock position
- Three pre-selectable speed stages for load adjustment ("S" type only)

# Standard Circulating Pumps

## Product review: Wilo-Star/Star S

### Equipment/function & technical data Wilo-Star (cast iron body)

	Wilo-Star... (cast iron body)							
	5 FX	16 F	16 FX	17 FX	21 F	21 FX	30 F	32 F
<b>Approved fluids</b> (other fluids on request)								
Heating water	•	•	•	•	•	•	•	•
Water/glycol mixtures (max. 1:1; mixtures with more than 20 % glycol require reassessment of the hydraulic criteria)	•	•	•	•	•	•	•	•
Domestic hot water	–	–	–	–	–	–	–	–
<b>Performance</b>								
Max. delivery head [ft]	5.5	16	16	17	21	21	30	33
Max. delivery head [m]	1.7	4.9	4.9	5.2	6.4	6.4	9.1	10.1
Max. volume rate of flow [USGPM]	12	16.5	16.5	50	19	19	26	10.5
Max. volume rate of flow [m <sup>3</sup> /h]	2.7	3.7	3.7	11.4	4.3	4.3	5.9	2.4
<b>Acceptable field of application</b>								
Temperature range for application in heating and cooling installations	14 °F (-10 °C) up to 230 °F (+110 °C)							
Temperature range in domestic hot water system	–	–	–	–	–	–	–	–
Ambient temperature range	104 °F (+40 °C)							
Max. working pressure p <sub>max</sub> [psi]	140	140	140	140	140	140	140	140
<b>Pipe connections</b>								
Flange	–	•	–	–	•	–	•	•
Flange rotated 90°	•	–	•	•	–	•	–	–
Union connection	–	–	–	–	–	–	–	–
Internal sweat	–	–	–	–	–	–	–	–
<b>Electrical connections</b>								
Power supply 1~ [V]	115	115	115	115	115	115	115	115
Power frequency [Hz]	60	60	60	60	60	60	60	60
Quick connection with spring clips	•	•	•	•	•	•	•	•
<b>Motor/Electronics</b>								
Number of speed steps	1	1	1	1	1	1	1	1
Impedance protected motor (motor protection not required)	•	•	•	•	•	•	•	•
Cable entry on both sides of terminal box	•	•	•	•	•	•	•	•
Protection class	F	F	F	F	F	F	F	F

• = available, – = not available

# Standard Circulating Pumps

Product review: Wilo-Star/Star S



## Equipment/function & technical data Wilo-Star (cast iron body)

	Wilo-Star... (cast iron body)							
	5 FX	16 F	16 FX	17 FX	21 F	21 FX	30 F	32 F
<b>Materials</b>								
Pump housing – cast iron	•	•	•	•	•	•	•	•
Pump housing – bronze	–	–	–	–	–	–	–	–
Impeller	Engineered Composite (PP – 40 % GF)							
Shaft	Stainless steel (X40 Cr13)							
Bearing	Metal impregnated carbon							
<b>Scope of delivery</b>								
Pump	•	•	•	•	•	•	•	•
Flange gaskets	•	•	•	•	•	•	•	•
Installation and operating instructions	•	•	•	•	•	•	•	•
<b>Minimal static inlet pressure at pump suction port [psi] to avoid cavitation at fluid temperatures</b>								
122 °F (50 °C)	0.7	0.7	0.7	0.7	0.7	0.7	0.7	0.7
203 °F (95 °C)	4.4	4.4	4.4	4.4	4.4	4.4	4.4	4.4
230 °F (110 °C)	14.5	14.5	14.5	14.5	14.5	14.5	14.5	14.5

• = available, – = not available

# Standard Circulating Pumps

## Product review: Wilo-Star/Star S

### Equipment/function & technical data Wilo-Star S (cast iron body)

	Wilo-Star S... (cast iron body)			
	S 16 F	S 16 FX	S 21 F	S 21 FX
<b>Approved fluids</b> (other fluids on request)				
Heating water	•	•	•	•
Water/glycol mixtures (max. 1:1; mixtures with more than 20 % glycol require reassessment of the hydraulic criteria)	•	•	•	•
Domestic hot water	–	–	–	–
<b>Performance</b>				
Max. delivery head [ft]	16	16	21	21
Max. delivery head [m]	4.9	4.9	6.4	6.4
Max. volume rate of flow [USGPM]	16.5	16.5	19	19
Max. volume rate of flow [m <sup>3</sup> /h]	3.7	3.7	4.3	4.3
<b>Acceptable field of application</b>				
Temperature range for application in heating and cooling installations	14 °F (-10 °C) up to 230 °F (+110 °C)			
Temperature range in domestic hot water system	–	–	–	–
Ambient temperature range	104 °F (+40 °C)	104 °F (+40 °C)	104 °F (+40 °C)	104 °F (+40 °C)
Max. working pressure p <sub>max</sub> [psi]	140	140	140	140
<b>Pipe connections</b>				
Flange	•	–	•	–
Flange rotated 90°	–	•	–	•
Union connection	–	–	–	–
Internal sweat	–	–	–	–
<b>Electrical connections</b>				
Power supply 1~ [V]	115	115	115	115
Power frequency [Hz]	60	60	60	60
Quick connection with spring clips	•	•	•	•
<b>Motor/Electronics</b>				
Number of speed steps	3	3	3	3
Impedance protected motor (motor protection not required)	•	•	•	•
Cable entry on both sides of terminal box	•	•	•	•
Protection class	F	F	F	F

• = available, – = not available

# Standard Circulating Pumps

Product review: Wilo-Star/Star S



## Equipment/function & technical data Wilo-Star S (cast iron body)

	Wilo-Star S... (cast iron body)			
	S 16 F	S 16 FX	S 21 F	S 21 FX
<b>Materials</b>				
Pump housing – cast iron	•	•	•	•
Pump housing – bronze	–	–	–	–
Impeller	Engineered Composite (PP – 40 % GF)			
Shaft	Stainless steel (X40 Cr13)			
Bearing	Metal impregnated carbon			
<b>Scope of delivery</b>				
Pump	•	•	•	•
Flange gaskets	•	•	•	•
Installation and operating instructions	•	•	•	•
<b>Minimal static inlet pressure at pump suction port [psi] to avoid cavitation at fluid temperatures</b>				
122 °F (50 °C)	0.7	0.7	0.7	0.7
203 °F (95 °C)	4.4	4.4	4.4	4.4
230 °F (110 °C)	14.5	14.5	14.5	14.5

• = available, – = not available

# Standard Circulating Pumps

Product review: Wilo-Star/Star S

## Equipment/function & technical data Wilo-Star (bronze body)

	Wilo-Star... (bronze body)								
	3 BS	5 BU	5 BFX	8 BS	11 BU	16 BFX	21 BFX	30 BU	32 BF
<b>Approved fluids</b> (other fluids on request)									
Heating water	•	•	•	•	•	•	•	•	•
Water/glycol mixtures (max. 1:1; mixtures with more than 20 % glycol require reassessment of the hydraulic criteria)	•	•	•	•	•	•	•	•	•
Domestic hot water	•	•	•	•	•	•	•	•	•
<b>Performance</b>									
Max. delivery head [ft]	3.5	6.5	6.5	9	11.5	16	21	30	33
Max. delivery head [m]	1.1	2.0	2.0	2.7	3.5	4.9	6.4	9.1	10.1
Max. volume rate of flow [USGPM]	5.5	12	12	9	19.5	16.5	19	26	10.5
Max. volume rate of flow [m <sup>3</sup> /h]	1.2	2.7	2.7	2.0	4.4	3.7	4.3	5.9	2.4
<b>Acceptable field of application</b>									
Temperature range for application in heating and cooling installations	14 °F (-10 °C) up to 230 °F (+110 °C)								
Temperature range in domestic hot water system	< 140 °F (+60 °C)								
Ambient temperature range	104 °F (+40 °C)								
Max. working pressure p <sub>max</sub> [psi]	140	140	140	140	140	140	140	140	140
<b>Pipe connections</b>									
Flange	–	–	–	–	–	–	–	–	•
Flange rotated 90°	–	–	•	–	–	•	•	–	–
Union connection	–	•	–	–	•	–	–	•	–
Internal sweat	•	–	–	•	–	–	–	–	–
<b>Electrical connections</b>									
Power supply 1~ [V]	115	115	115	115	115	115	115	115	115
Power frequency [Hz]	60	60	60	60	60	60	60	60	60
Quick connection with spring clips	•	•	•	•	•	•	•	•	•
<b>Motor/Electronics</b>									
Number of speed steps	1	1	1	1	1	1	1	1	1
Impedance protected motor (motor protection not required)	•	•	•	•	•	•	•	•	•
Cable entry on both sides of terminal box	•	•	•	•	•	•	•	•	•
Protection class	F	F	F	F	F	F	F	F	F

• = available, – = not available

# Standard Circulating Pumps

Product review: Wilo-Star/Star S



## Equipment/function & technical data Wilo-Star (bronze body)

	Wilo-Star... (bronze body)								
	3 BS	5 BU	5 BFX	8 BS	11 BU	16 BFX	21 BFX	30 BU	32 BF
<b>Materials</b>									
Pump housing – cast iron	–	–	–	–	–	–	–	–	–
Pump housing – bronze	•	•	•	•	•	•	•	•	•
Impeller	Engineered Composite (PP – 40 % GF)								
Shaft	Stainless steel (X40 Cr13)								
Bearing	Metal impregnated carbon								
<b>Scope of delivery</b>									
Pump	•	•	•	•	•	•	•	•	•
Flange gaskets	–	–	•	–	–	•	•	–	•
Installation and operating instructions	•	•	•	•	•	•	•	•	•
<b>Minimal static inlet pressure at pump suction port [psi] to avoid cavitation at fluid temperatures</b>									
122 °F (50 °C)	0.7	0.7	0.7	0.7	0.7	0.7	0.7	0.7	0.7
203 °F (95 °C)	4.4	4.4	4.4	4.4	4.4	4.4	4.4	4.4	4.4
230 °F (110 °C)	14.5	14.5	14.5	14.5	14.5	14.5	14.5	14.5	14.5

• = available, – = not available

# Standard Circulating Pumps

## Product review: Wilo-Star/Star S

### Equipment/function & technical data Wilo-Star S (bronze body)

	Wilo-Star S... (bronze body)	
	S 16 BFX	S 21 BFX
<b>Approved fluids</b> (other fluids on request)		
Heating water	•	•
Water/glycol mixtures (max. 1:1; mixtures with more than 20 % glycol require reassessment of the hydraulic criteria)	•	•
Domestic hot water	•	•
<b>Performance</b>		
Max. delivery head [ft]	16	21
Max. delivery head [m]	4.9	6.4
Max. volume rate of flow [USGPM]	16.5	19
Max. volume rate of flow [m <sup>3</sup> /h]	3.7	4.3
<b>Acceptable field of application</b>		
Temperature range for application in heating and cooling installations	14 °F (-10 °C) up to 230 °F (+110 °C)	
Temperature range in domestic hot water system	–	–
Ambient temperature range	104 °F (+40 °C)	104 °F (+40 °C)
Max. working pressure p <sub>max</sub> [psi]	140	140
<b>Pipe connections</b>		
Flange	–	–
Flange rotated 90°	•	•
Union connection	–	–
Internal sweat	–	–
<b>Electrical connections</b>		
Power supply 1~ [V]	115	115
Power frequency [Hz]	60	60
Quick connection with spring clips	•	•
<b>Motor/Electronics</b>		
Number of speed steps	3	3
Impedance protected motor (motor protection not required)	•	•
Cable entry on both sides of terminal box	•	•
Protection class	F	F

• = available, – = not available



# Standard Circulating Pumps

Product review: Wilo-Star/Star S



## Equipment/function & technical data Wilo-Star S (bronze body)

	Wilo-Star S... (bronze body)	
	S 16 BFX	S 21 BFX
<b>Materials</b>		
Pump housing - cast iron	–	–
Pump housing - bronze	•	•
Impeller	Engineered Composite (PP – 40 % GF)	
Shaft	Stainless steel (X40 Cr13)	
Bearing	Metal impregnated carbon	
<b>Scope of delivery</b>		
Pump	•	•
Flange gaskets	•	•
Installation and operating instructions	•	•
<b>Minimal static inlet pressure at pump suction port [psi] to avoid cavitation at fluid temperatures</b>		
122 °F (50 °C)	0.7	0.7
203 °F (95 °C)	4.4	4.4
230 °F (110 °C)	14.5	14.5

• = available, – = not available

# Standard Circulating Pumps

## Wilco-Star/Star S

### Pump curves Wilco-Star

**Wilco-Star 3 BS**

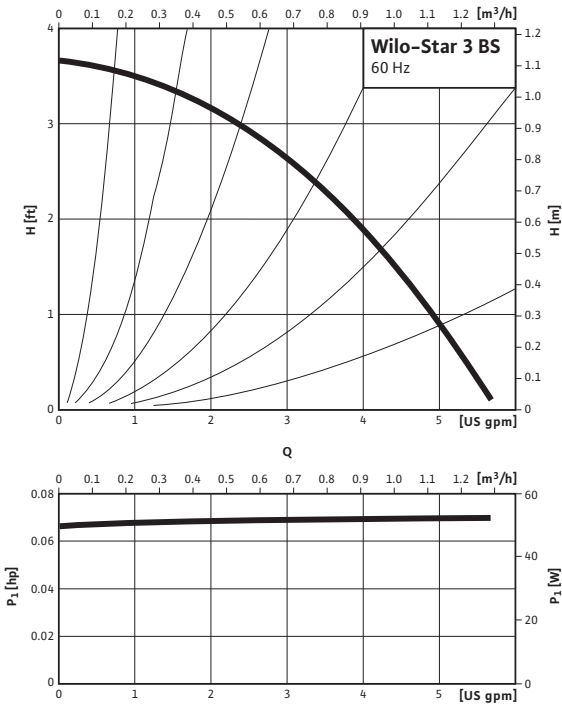

**Wilco-Star 5 FX, BU, BFX**

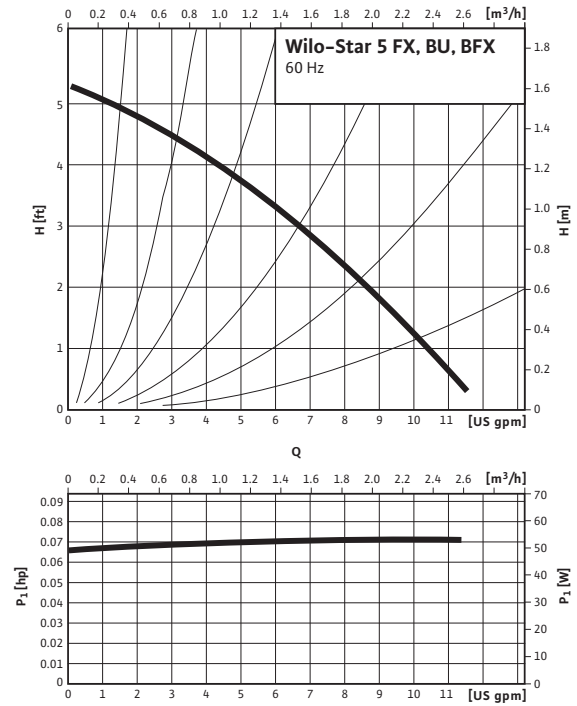

**Wilco-Star 8 BS**

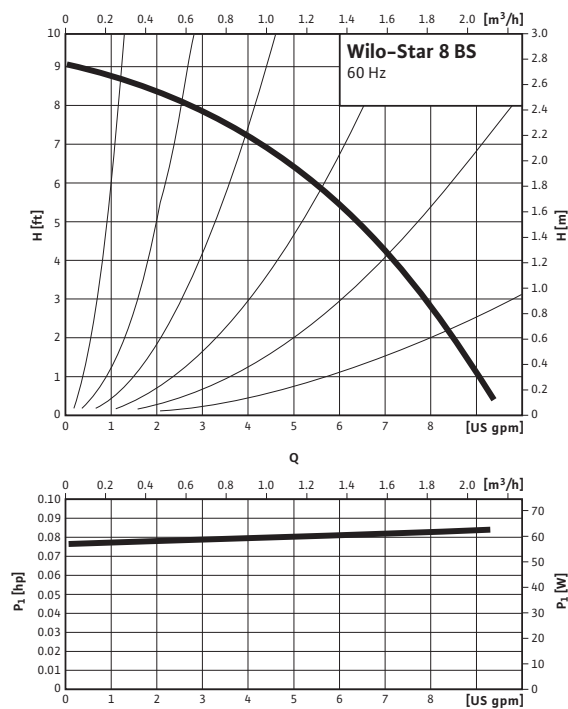

**Wilco-Star 11 BU**

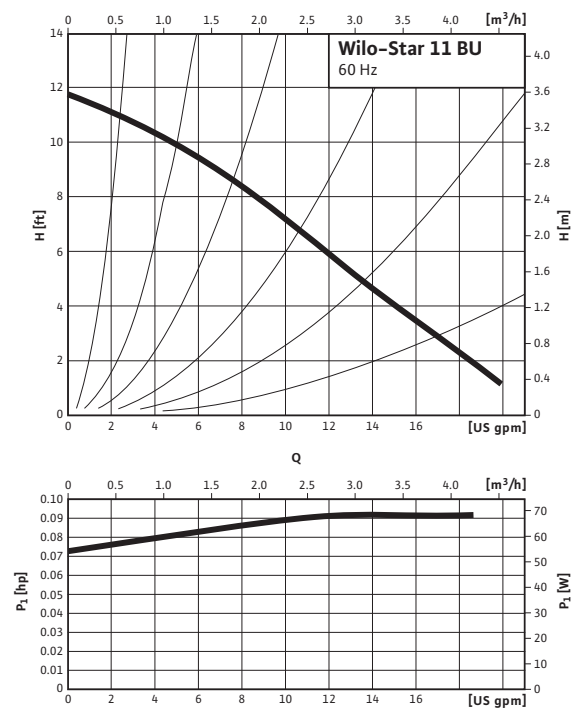

# Standard Circulating Pumps

Wilo-Star/Star S



## Pump curves Wilo-Star

Wilo-Star 16 F, FX, BFX

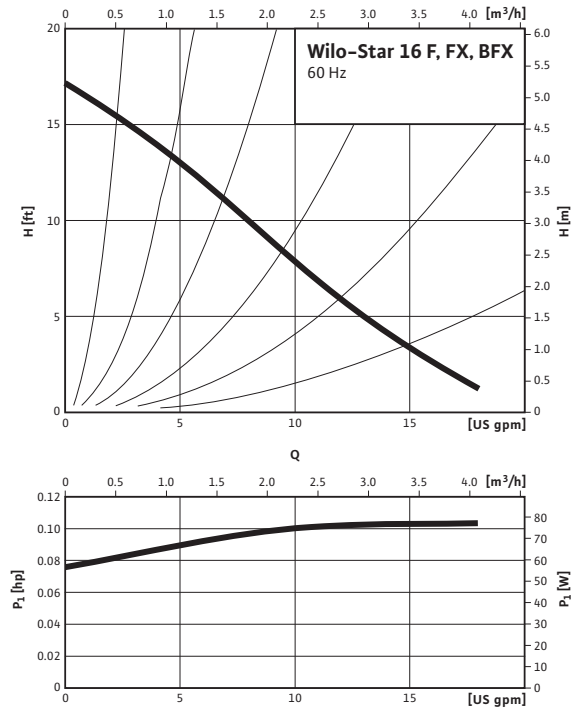

Wilo-Star 17 FX

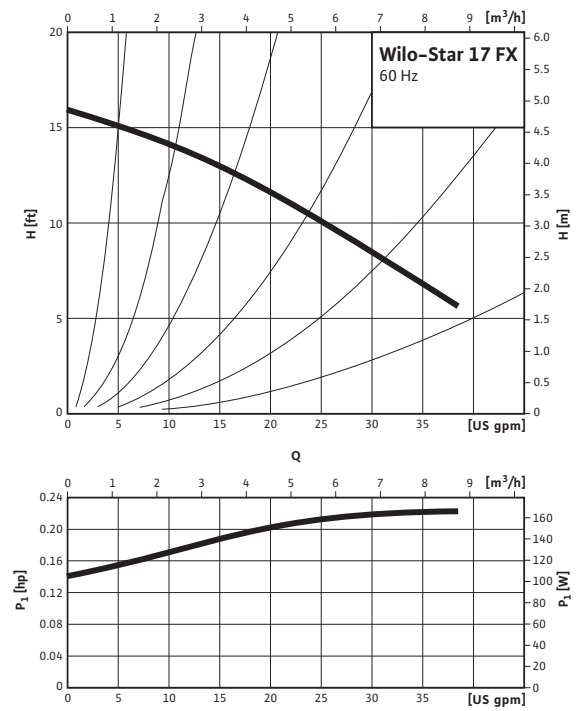

Wilo-Star 21 F, FX, BFX

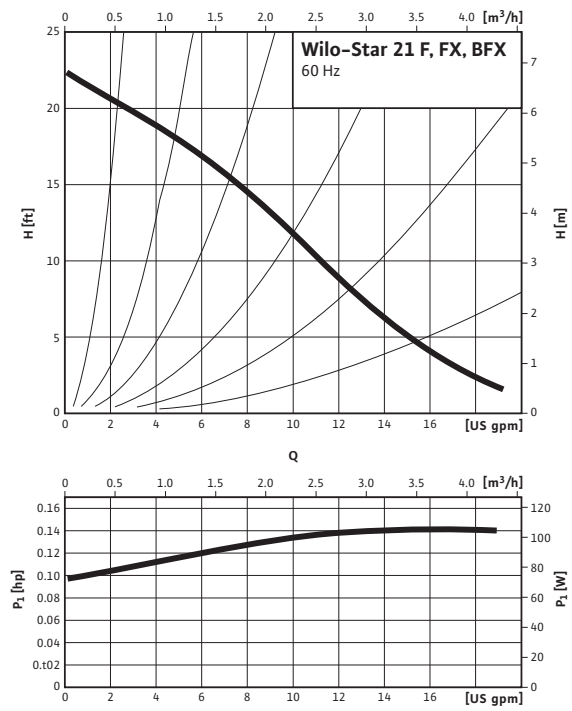

Wilo-Star 30 F, BU

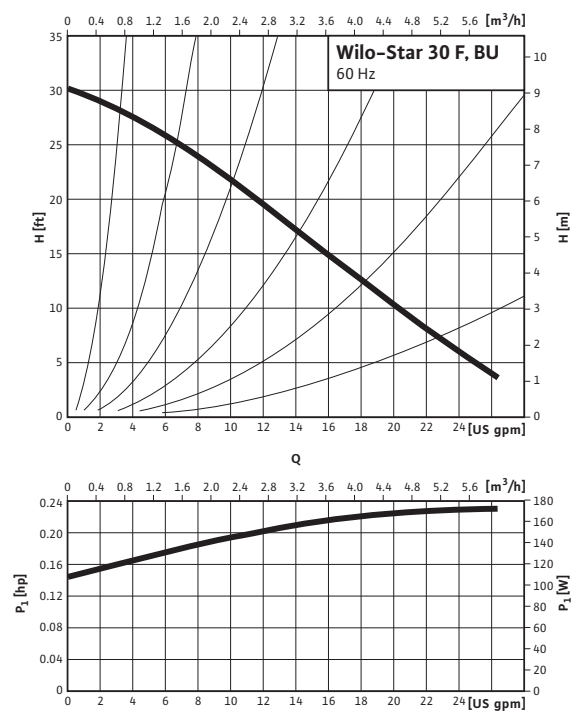

# Standard Circulating Pumps

Wilco-Star/Star S

## Pump curves Wilco-Star

Wilco-Star 32 F

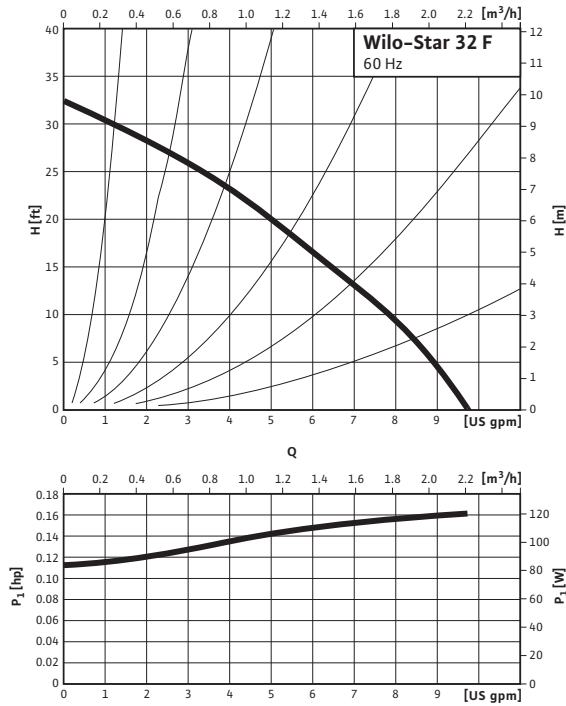

Wilco-Star 32 BF

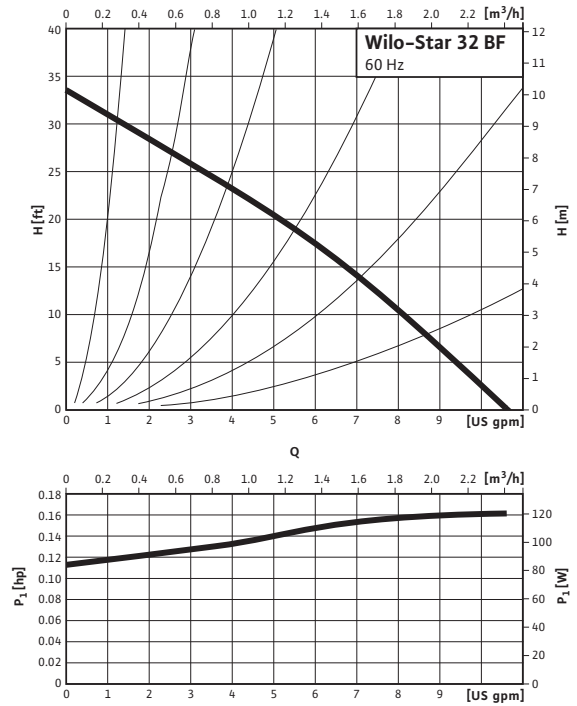

# Standard Circulating Pumps

Wilo-Star/Star S



## Pump curves Wilo-Star S

Wilo-Star S 16 F, FX, BFX

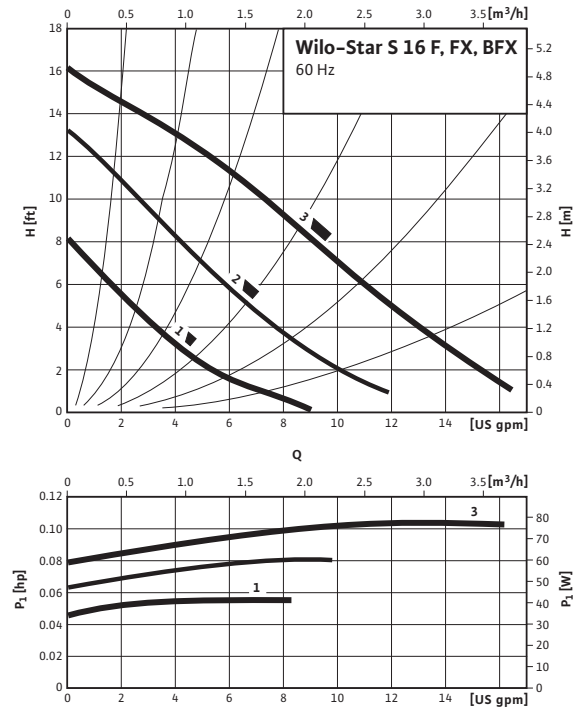

Wilo-Star S 21 F, FX, BFX

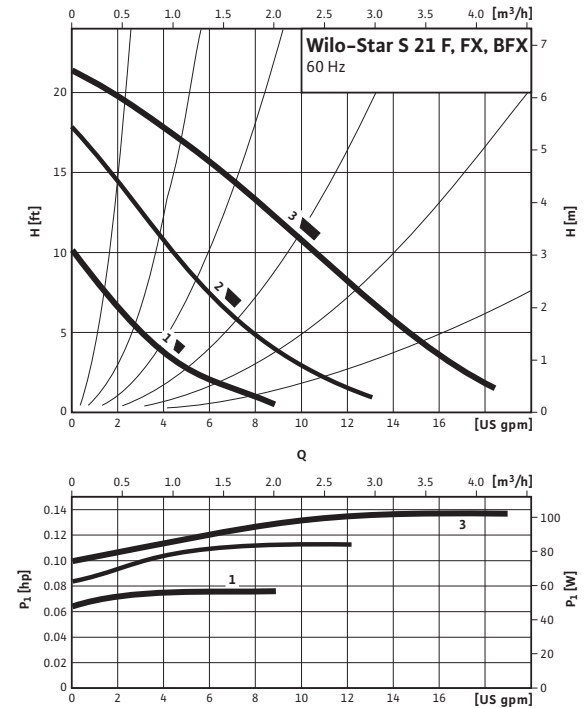

# Standard Circulating Pumps

Wilo-Star/Star S

## Wiring diagrams, motor data

### Wiring diagram

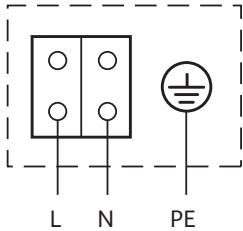

Single phase motor 2-pole, 1~115 V/60 Hz  
with integrated capacitor

### Motor data Wilo-Star

Wilo-Star...	Rated Power		Speed	Power consumption		Current 1~115 V, 60 Hz	Motor protection	Capacitor
	P <sub>2</sub>		n	P <sub>1</sub>		I	-	-
	[hp]	[W]	[rpm]	[hp]	[W]	[A]	-	[μF]
Star 3...	0.03	20	3400	0.07	50	0.49	not necessary (blocking- current-proof)	7
Star 5...	0.03	20	2700	0.07	50	0.49		7
Star 8...	0.03	20	3000	0.09	64	0.58		7
Star 11...	0.03	20	3000	0.09	64	0.58		7
Star 16...	0.05	35	2700	0.11	80	0.66		7
Star 17...	0.10	70	3000	0.24	166	1.45		12
Star 21...	0.05	40	2700	0.15	110	0.92		9
Star 30...	0.10	70	2700	0.24	173	1.50		12

### Motor data Wilo-Star S...

Wilo-Star S...	Rated Power		Speed	Power consumption		Current 1~115 V, 60 Hz	Motor protection	Capacitor
	P <sub>2</sub>		n	P <sub>1</sub>		I	-	-
	[hp]	[W]	[rpm]	[hp]	[W]	[A]	-	[μF]
Star S 16...	0.05	35	max. 2700	0.10	80	0.66	not necessary (blocking- current-proof)	7
			2200	0.08	60	0.55		
			min. 1600	0.05	41	0.38		
Star S 21...	0.05	40	max. 2700	0.13	110	0.92		9
			2100	0.10	83	0.75		
			min. 1300	0.07	56	0.52		

# Standard Circulating Pumps

Wilo-Star/Star S



## Dimensions, weights

Wilo-Star, Drawing no.: 1

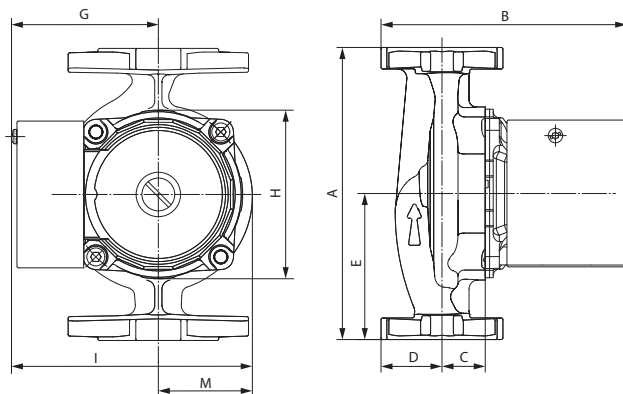

Wilo-Star, Drawing no.: 2

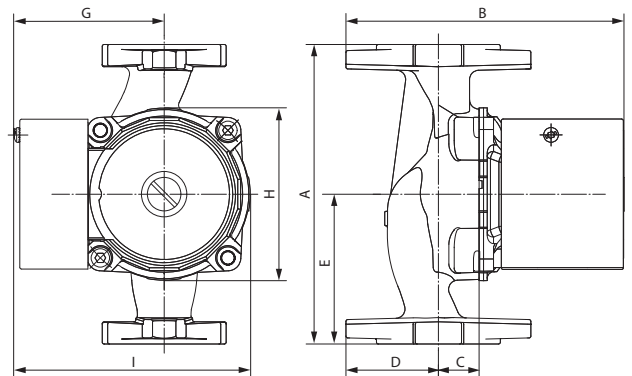

Wilo-Star, Drawing no.: 3

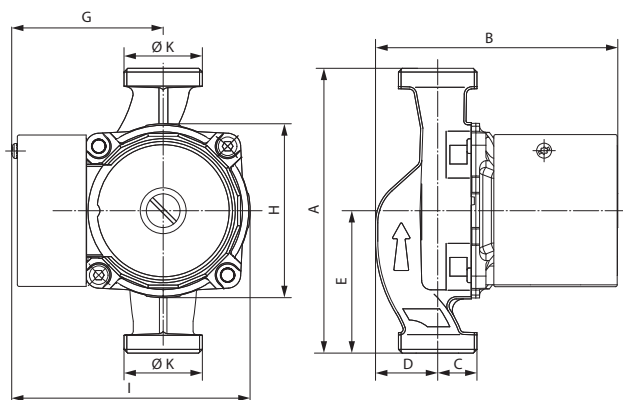

Wilo-Star, Drawing no.: 4

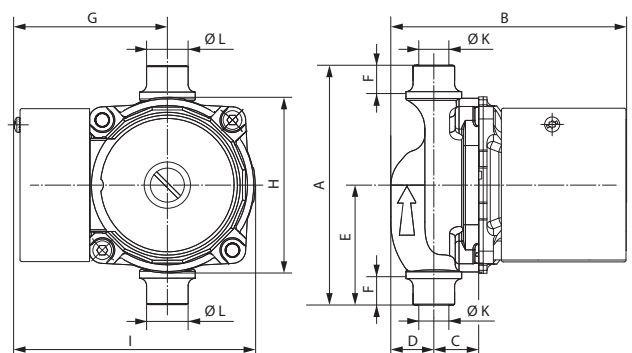

Wilo-Star S, Drawing no.: 5

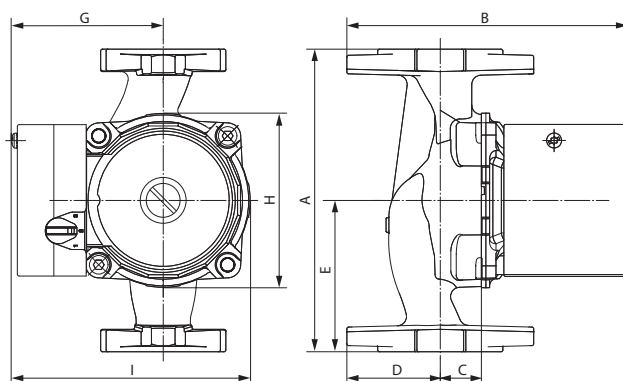

# Standard Circulating Pumps

Wilo-Star/Star S

## Dimensions, weights

inch

Wilo-Star...	A	B	C	D	E	F	G	H	I	Ø K	Ø L	M	Weight approx. [lbs]	Drawing No.
	[in]	[in]	[in]	[in]	[in]	[in]	[in]	[in]	[in]	[in]	[in]	[in]		
Star 3 BS 5	5	4 15/16	15/16	7/8	2 4/8	9/16	3 3/16	3 11/16	5 1/16	5/8	7/8	–	6.5	4
Star 3 BS 7	5	4 15/16	15/16	7/8	2 4/8	9/16	3 3/16	3 11/16	5 1/16	7/8	1 1/8	–	5.3	4
Star 5 BU	6	5 3/8	11/16	1 5/16	3	–	3 3/16	3 11/16	5 1/16	1 1/4 NPSM	–	–	6.5	3
Star 5 BFX	6 3/8	5 15/16	7/8	2	3 3/16	–	3 3/16	3 11/16	5 1/16	–	–	–	7.2	2
Star 5 FX	6 3/8	5 15/16	7/8	2	3 3/16	–	3 3/16	3 11/16	5 1/16	–	–	–	6.5	2
Star 8 BS 5	5	4 15/16	15/16	7/8	2 4/8	9/16	3 3/16	3 11/16	5 1/16	5/8	7/8	–	6.5	4
Star 8 BS 7	5	4 15/16	15/16	7/8	2 4/8	9/16	3 3/16	3 11/16	5 1/16	7/8	1 1/8	–	5.3	4
Star 11 BU	6	5 3/8	11/16	1 5/16	3	–	3 3/16	3 11/16	5 1/16	1 1/4 NPSM	–	–	6.5	3
Star 16 F	6 3/8	5 1/4	7/8	1 5/16	3 3/16	–	3 1/4	3 11/16	5 3/16	5 3/16	–	–	6.5	1
Star 16 FX	6 3/8	5 15/16	7/8	2	3 3/16	–	3 3/16	3 11/16	5 1/16	–	–	–	6.5	2
Star 16 BFX	6 3/8	5 15/16	7/8	2	3 3/16	–	3 3/16	3 11/16	5 1/16	–	–	–	7.2	2
Star 17 FX	8 1/2	7	1 2/7	2 3/16	4 1/4	–	3 2/9	3 7/9	5 1/8	–	–	–	10.8	2
Star 21 F	6 3/8	5 1/4	7/8	1 5/16	3 3/16	–	3 1/4	3 11/16	5 3/16	–	–	–	6.5	1
Star 21 FX	6 3/8	5 15/16	7/8	2	3 3/16	–	3 3/16	3 11/16	5 1/16	–	–	–	6.5	2
Star 21 BFX	6 3/8	5 15/16	7/8	2	3 3/16	–	3 3/16	3 11/16	5 1/16	–	–	–	7.1	2
Star 30 BU	6	6 1/8	1 1/4	1 3/8	3	–	3 1/4	3 3/4	5 1/8	–	–	–	7.7	3
Star 30 F	6 1/2	6	1 1/4	1 5/16	3 1/4	–	3 1/4	3 3/4	5 3/16	–	–	1 15/16	8.0	1
Star 32 BF	6 3/8	5 3/8	1/16	1 5/16	3 3/16	–	3 3/16	3 11/16	5 1/16	–	–	2 1/16	7.7	1
Star 32 F	6 3/8	5 3/8	15/16	1 5/16	3 3/16	–	3 3/16	3 11/16	5 1/16	–	–	2 1/16	6.7	1
Star S 16 F	6 3/8	6 3/8	7/8	2	3 3/16	–	3 3/16	3 11/16	5 1/16	–	–	–	6.5	5
Star S 16 FX	6 3/8	6 3/8	7/8	2	3 3/16	–	3 3/16	3 11/16	5 1/16	–	–	–	6.5	5
Star S 16 BFX	6 3/8	6 3/8	7/8	2	3 3/16	–	3 3/16	3 11/16	5 1/16	–	–	–	7.0	5
Star S 21 F	6 3/8	6 3/8	7/8	2	3 3/16	–	3 3/16	3 11/16	5 1/16	–	–	–	6.5	5
Star S 21 FX	6 3/8	6 3/8	7/8	2	3 3/16	–	3 3/16	3 11/16	5 1/16	–	–	–	6.5	5
Star S 21 BFX	6 3/8	6 3/8	7/8	2	3 3/16	–	3 3/16	3 11/16	5 1/16	–	–	–	7.1	5



# Standard Circulating Pumps

Wilo-Star/Star S



## Dimensions, weights

metric														
Wilo-Star...	A	B	C	D	E	F	G	H	I	Ø K	Ø L	M	Weight approx.	Draw- ing No.
	[mm]	[mm]	[mm]	[mm]	[mm]	[mm]	[mm]	[mm]	[mm]	[mm]	[mm]	[mm]	[kg]	
Star 3 BS 5	127	125	24	23	64	15	81	93.5	128	16	22	–	3.0	4
Star 3 BS 7	127	125	24	23	64	15	81	93.5	128	22	28	–	2.4	4
Star 5 BU	152	130	18	33	76	–	81	93.5	128	–	–	–	3.0	3
Star 5 BFX	162	150	22	50	81	–	81	93.5	128	–	–	–	3.3	2
Star 5 FX	162	150	22	50	81	–	81	93.5	128	–	–	–	3.0	2
Star 8 BS 5	127	125	24	23	64	15	81	93.5	128	16	22	–	3.0	4
Star 8 BS 7	127	125	24	23	64	15	81	93.5	128	22	28	–	2.4	4
Star 11 BU	152	130	18	33	76	–	81	93.5	128	–	–	–	3.0	3
Star 16 F	162	134	22	34	81	–	82	93.5	132	–	–	–	3.0	1
Star 16 FX	162	150	22	50	81	–	81	93.5	128	–	–	–	3.0	2
Star 16 BFX	162	150	22	50	81	–	81	93.5	128	–	–	–	3.3	2
Star 17 FX	216	176	33	55	108	–	82	96.0	130	–	–	–	4.9	2
Star 21 F	162	134	22	34	81	–	82	93.5	132	–	–	–	3.0	1
Star 21 FX	162	150	22	50	81	–	81	93.5	128	–	–	–	3.0	2
Star 21 BFX	162	150	22	50	81	–	81	93.5	128	–	–	–	3.2	2
Star 30 BU	152	155	32	35	76	–	82	96	130	–	–	–	3.5	3
Star 30 F	165	153	31	34	83	–	82	96.0	132	–	–	50	3.7	1
Star 32 BF	162	136	24	34	81	–	81	93.5	128	–	–	52	3.5	1
Star 32 F	162	136	24	34	81	–	81	93.5	128	–	–	52	3.1	1
Star S 16 F	162	154	22	50	81	–	81	93.5	128	–	–	–	3.0	5
Star S 16 FX	162	154	22	50	81	–	81	93.5	128	–	–	–	3.0	5
Star S 16 BFX	162	154	22	50	81	–	81	93.5	128	–	–	–	3.2	5
Star S 21 F	162	154	22	50	81	–	81	93.5	128	–	–	–	3.0	5
Star S 21 FX	162	154	22	50	81	–	81	93.5	128	–	–	–	3.0	5
Star S 21 BFX	162	154	22	50	81	–	81	93.5	128	–	–	–	3.3	5

# Standard Circulating Pumps

Wilo-Star/Star S

## Dimensions, weights