

# C7400S Enthalpy Sylk Bus Sensor

## INSTALLATION INSTRUCTIONS



## PRODUCT DESCRIPTION

The C7400S Sylk Bus sensor is a combination temperature and humidity sensor, which is intended to be used in commercial roof top units for sensing air. The sensor is powered by and communicates on the Sylk Bus. The C7400S communicates temperature and humidity separately digitally on the Sylk Bus Communication Protocol.

A separate controller such as the JADE™ Economizer System (Model W7220) provides power and communications on the Sylk Bus for the C7400S Sylk Bus sensor.

## SPECIFICATIONS

### Electrical

**Supply Voltage:** 7 to 21 Vdc

**Power Consumption:** 5 mA

**Output Rating:** 75 ohm load switched at 9600 Baud

**Wiring:** Sylk Bus: 2-wire (18 to 22 AWG)

### Environmental

**Operating Temperature range:** -40 to 150 °F (-40 to 65 °C)

**Storage Temperature range:** -40 to 150 °F (-40 to 65 °C)

**Shipping Temperature range:** -40 to 150 °F (-40 to 65 °C)

**Operating Relative Humidity range:** 5% to 95% RH non-condensing

### Temperature and Humidity, C7400S:

Temperature sensing range: -40 to 150 °F (-40 to 65 °C)  
Humidity sensing range: 0 to 100% RH with 5% accuracy.

### Dimensions (See Fig. 1):

Height: 0.8 inches (20.5 mm)

Width: 2.17 inches (55 mm)

Length: 4.25 inches (108 mm)

**Weight:** 0.58 lb. (0.265 kg)

### Listing Agency Approvals:

EN61000-6-3, EN61000-3-2, EN61000-3-3, EN61000-6-1;

EN60730-1 Annex H.23 (emissions)

Annex H.26 (immunity)

CE Mark FOR EU

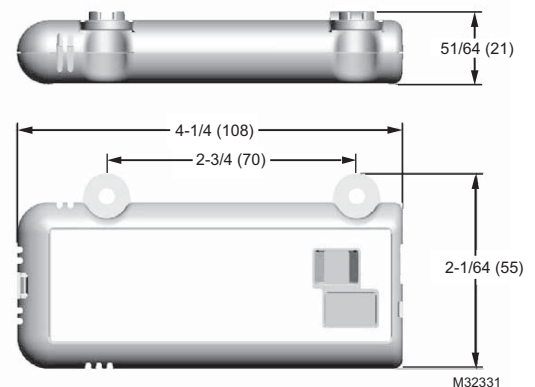

Fig. 1. Dimensions in inches and (mm) showing mounting holes.

## BEFORE INSTALLATION

Review the “Specifications” on page 1 before installing the sensor.

### When Installing This Product

1. Read these instructions carefully. Failure to follow them could damage the product or cause a hazardous condition.
2. Check ratings given in instructions and on the product to ensure the product is suitable for your application.
3. Installer must be a trained, experienced service technician.

## INSTALLATION AND SETUP

The following installation procedures should be performed in the order listed:

1. Mounting — see “Mounting” on this page.
2. Wiring — see “Wiring” on page 3.
3. Checkout — see “Checkout” on page 3.

## MOUNTING

### IMPORTANT

*Avoid mounting in areas where acid fumes or other deteriorating vapors can attack the metal parts of the sensor, or in areas where escaping gas or other explosive vapors are present.*

### IMPORTANT

*The sensor must be mounted in a position that allows clearance for wiring, servicing, and removal.*

The sensor is mounted directly to the sheet metal using self tapping sheet metal screws or in the air stream using the duct mounting kit. Use #6 or #8 screws (screws are not provided and must be obtained separately).

**NOTE:** Maximum torque of the mounting screws is 17.7 lb-in (2 Nm).

Use the dimensions in Fig. 1 on page 1 as a guide.

The sensor must be mounted to allow air flow through the sensor housing vent slots on the end or side.

The Sylk Bus sensor communicates with a controller (such as the JADE™ Economizer Model W7220) on the two-wire communication bus and can either be wired using a two pin header or using a side connector. The unit pack Sylk Bus sensor includes a two pin Euro connector with the packaging. The SKU number of the Sylk Bus sensor is C7400S. All OAT (Outdoor Air Temperature), RAT (Return Air Temperature) and DAT (Discharge Air Temperature) sensors are the same SKU number. The sensor is set for the appropriate type of sensing using the three position DIP switch located on the sensor. OAT position is OFF, OFF, OFF; RAT is ON, OFF, OFF and DAT is OFF, ON, OFF. During installation the sensors are set for the appropriate usage. See “Syilk Bus Sensor Wiring” on page 3 for DIP switch details.

Once installed, a sensor can be changed to a different application by simply changing the DIP switch setting.

### Sensor Mounting

The sensor can be mounted directly on to the sheet metal of the unit or can be mounted in the air stream using the duct mounting kit.

The duct mounting kit contains a rod to hold the sensor in the duct, a flange to secure the sensor rod to the duct wall and to fill the hole, and a gasket to prevent air from leaking through the duct wall. See Fig. 2.

The rod has slots for threading the wire to prevent loose or hanging wire in the duct and can be adjusted for 6 or 12 inch length. The flange has extended relief for ease of mounting. See Fig. 3.

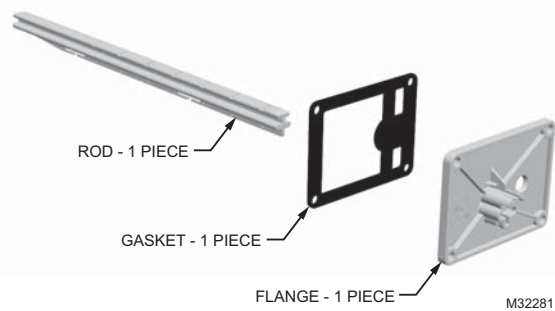

**Fig. 2. Duct Mounting Kit (Part # 50053060-001).**

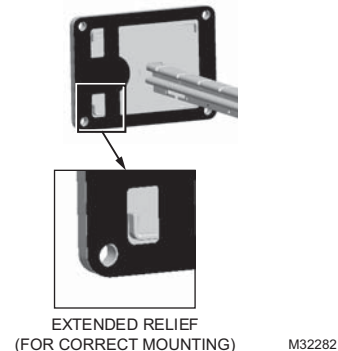
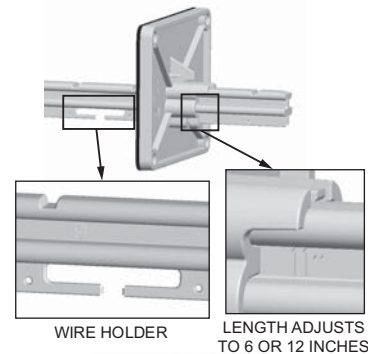

**Fig. 3. Duct Mounting Adjustments.**

## WIRING

All wiring must comply with applicable electrical codes and ordinances, or as specified on installation wiring diagrams.



### WARNING

**Electrical Shock Hazard.**  
Can cause severe injury, death or property damage.

Disconnect power supply before beginning wiring, or making wiring connections, to prevent electrical shock or equipment damage.



### CAUTION

**Equipment Damage Hazard.**  
Electrostatic discharge can short equipment circuitry.

Ensure that you are properly grounded before handling the sensor.

Prepare wiring as follows:

1. Strip 1/2 in. (13 mm) insulation from the conductor.
2. Cut a single wire to 3/16 in. (5 mm). Insert the wire in the required terminal location and tighten the screw.
3. Pull on each wire in all terminals to check for good mechanical connection.

### Sylk Bus Sensor Wiring

Use Fig. 4 and Table 1 to locate the wiring terminals for each Sylk Bus sensor.

Use Fig. 4 and Table 2 to set the DIP switches for the desired use of the sensor.

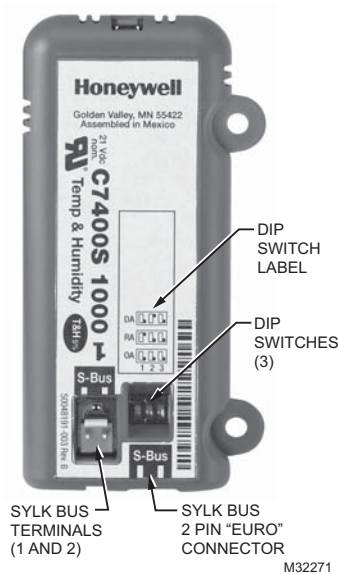

Fig. 4. Sylk Bus sensor DIP switches.

Table 1. SYLK Bus Sensor Wiring Terminations<sup>a</sup>.

Terminal		Type	Description
Nbr	Label		
1	S-BUS	SYLK Bus	Sylk Bus Communications (Sensor Bus)
2	S-BUS	SYLK Bus	Sylk Bus Communications (Sensor Bus)

<sup>a</sup> Terminals are polarity insensitive.

Table 2. SYLK Bus Sensor DIP Switch Settings.

Use	DIP Switch Positions for Switches 1, 2, & 3		
	1	2	3
DA <sup>a</sup>	OFF	ON	OFF
RA <sup>b</sup>	ON	OFF	OFF
OA <sup>c</sup>	OFF	OFF	OFF

<sup>a</sup> DA = Discharge Air

<sup>b</sup> RA = Return Air

<sup>c</sup> OA = Outside Air

## CHECKOUT

Refer to the *JADE™ Economizer Module (Model W7220)* Installation Instructions (Honeywell form 62-0331).

## TROUBLESHOOTING

Refer to the *JADE™ Economizer Module (Model W7220)* Installation Instructions (Honeywell form 62-0331).

*JADE™ is a trademark of Honeywell, Inc.*

By using this Honeywell literature, you agree that Honeywell will have no liability for any damages arising out of your use or modification to, the literature. You will defend and indemnify Honeywell, its affiliates and subsidiaries, from and against any liability, cost, or damages, including attorneys' fees, arising out of, or resulting from, any modification to the literature by you.

**Automation and Control Solutions**

Honeywell International Inc.  
1985 Douglas Drive North  
Golden Valley, MN 55422  
customer.honeywell.com

© U.S. Registered Trademark  
© 2012 Honeywell International Inc.  
62-0332—05 M.S. Rev. 08-12  
Printed in United States

**Honeywell**