

### APPLICATION

R8229A Switching Relay and R8246A Contactor provide switching for resistance electric heating loads. The relay and contactor have dpst switching and 24 Vac coils with constant 0.23 A current draw. The contacts are rated to allow a fan motor and 1 or 2 heating elements to be controlled by the same pole. They are designed for use only on Sears electric heat furnaces.

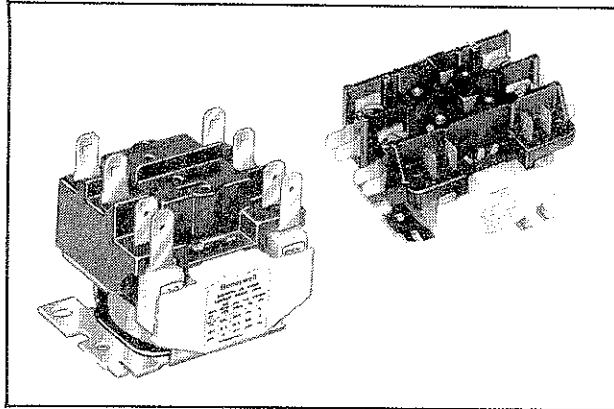

Fig. 1—R8229A Switching Relay and R8246A Contactor.

### INSTALLATION

#### SAFETY RULES

##### WHEN INSTALLING THIS PRODUCT . . .

1. Read these instructions carefully. Failure to follow them could damage the product or cause a hazardous condition.
2. Check the ratings given in the instructions to make sure the product is suitable for your application.
3. Make sure you know how to use the tools required in the installation and that you understand the potential hazards, or arrange for professional installation.
4. After installation is complete, check out product operation as provided in these instructions.

#### CAUTION

Disconnect electric power supply to avoid electrical shock and equipment damage.

#### LOCATION AND MOUNTING

The design of the furnace and the location of the original controls will guide the relay or contactor location. Make sure that the ambient temperature in the

selected area is within the 165 F [74 C] device rating. The control may be mounted in any position inside the furnace enclosure. It CANNOT be mounted on the outside.

1. Refer to the furnace wiring instructions.
2. Remove existing controls in the heating element circuits. DO NOT REMOVE—
  - fan speed changeover relay.
  - fuse blocks and terminal strips.
  - 24 V transformer.
  - limits and cutouts on the heaters.
3. Remove all the wiring from the switching relay or contactor to be replaced.
4. Seal all old screw holes with screws or duct tape.
5. Mount the relay or contactor with 2 screws through holes or slots in the mounting base.

NOTE: Use nuts and bolts when mounting on a surface where mounting hardware is exposed to the outside of the furnace.

#### WIRING

Disconnect electric power supply before connecting wiring to avoid electrical shock or equipment damage.

All wiring must comply with local codes and ordinances. The relays have molded terminal numbers and circuit diagrams, and the contactors have printed terminal designations for easy identification when wiring. Fig. 2 shows the internal circuits and typical hookups.

Do not exceed contact and coil ratings when wiring into system.

Replace the female quick-connects with new crimp type female quick-connect terminals. Follow the schematic for the system being serviced.

- a. Reconnect the low voltage thermostat, relay and contactor coil(s) and changeover relay wires.
- b. Reconnect the line voltage fan circuit wires. Be sure the fan lead wires are the same as the original to ensure proper fusing. The fan must be controlled by the relay or contactor that is connected to the thermostat.
- c. Reconnect the heater elements one at a time. Each of the line voltage wires ( $L_1$  and  $L_2$ ) must be wired to the element(s) with a fuse of equal rating. There should be no more than two 5 kW elements (2 elements and fan in combination-rated circuits) per fuse pair or contactor pole; one 5 kW element per relay pole.
- d. All pilot duty limits must be in the coil circuit of ALL relays and contactors, or a line voltage limit must remain wired with each heating element.

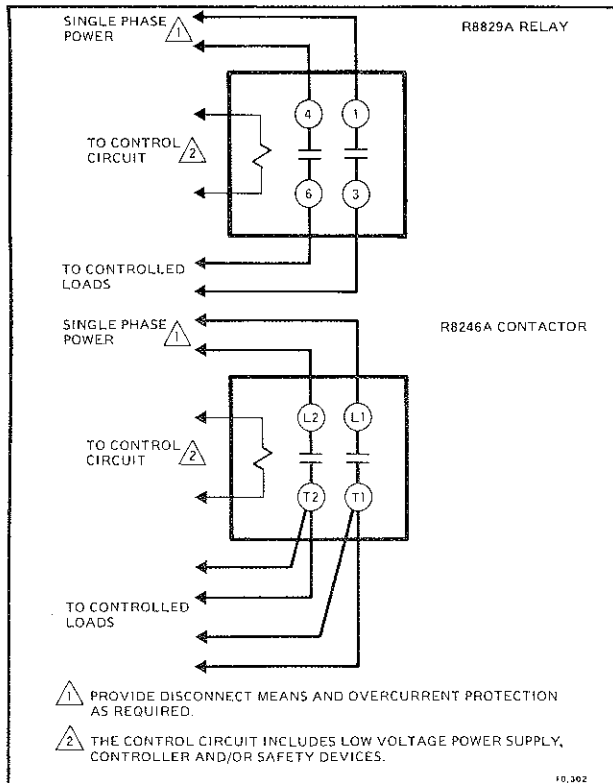

Fig. 2—Internal schematic for R8229A Relay and R8246A Contactor.

## CHECKOUT AND SERVICE

### CAUTION

The fan must be on whenever any heating elements are on.

### CHECKOUT

Set the system thermostat to call for heat. Make sure that all elements turn on and off properly and that the fan starts and stops with the elements. In pilot duty limit systems, relay(s), and contactor(s) should drop out when control circuit is de-energized by the pilot duty limit. Perform system checkout procedure in TROUBLESHOOTING section.

### SERVICE

The R8229A and R8246A are not field repairable. If any component fails, the entire control must be replaced. No adjustment or periodic maintenance is required on these controls.

## TROUBLESHOOTING

### CAUTION

The R8229A and R8246A contacts carry line voltage. Disconnect electric power supply before working with or checking wiring.

### PRELIMINARY CHECKOUT FOR SYSTEM WITH LINE VOLTAGE LIMITS

1. Check system wiring for any loose or broken connections.

2. With electric power off, disconnect the fan at the relay or contactor. Turn electric power on and set thermostat to call for heat. When heaters come on check the limit controls on the heaters for proper

operation. Replace any limit that does not de-energize its element.

Turn the thermostat to its lowest setting and turn the electric power off. Reconnect the fan and turn the electric power back on. Turn the furnace on and off to be sure that all of the heating elements operate properly.

### PRELIMINARY CHECKOUT FOR SYSTEM WITH PILOT DUTY LIMIT

1. Check system wiring for any loose or broken connections.

2. With electric power off, disconnect the fan at the relay or contactor. Turn electric power on and set thermostat to call for heat. When furnace temperature rises to limit set point, the pilot duty limit should open the control circuit to de-energize the relay or contactor(s). All elements must turn off. Replace limits which are not working properly.

Turn the thermostat to the lowest setting and turn the power off. Reconnect the fan and restore the electric power. Turn the furnace on and off to be sure that the fan and all of the heating elements are operating correctly.

### R8229A AND R8246A SYSTEM CHECKOUT

Refer to applicable wiring diagrams. Note that if several relays and/or contactors are used in combination, the troubleshooting procedure must be adapted for the individual system.

1. Move the thermostat set point above the room temperature so the thermostat calls for heat—

—If system does not start, proceed to step 2.

—If fan and/or some heating elements come on (but not all), proceed to step 3.

—If fan and all heating elements come on properly, proceed to step 4.

2. Jumper Rh to W1 at the thermostat—

—If fan and heating elements now begin operating, check thermostat and wiring and replace thermostat if necessary. Proceed to step 4.

—If neither fan nor heating elements operate (and system wiring was checked), replace the relay or contactor.

NOTE: See Preliminary Checkout for system with Pilot Duty Limit before replacing relay or contactor.

### CAUTION

The R8229A and R8246A contacts carry line voltage.

3. Jumper across the relay or contactor terminals controlling the inoperative fan or heating element. If the fan or element starts, the contacts are not conducting. Replace the relay or contactor.

NOTE: If element is not energized, check to see that the second stage of the thermostat is operating (or that R to W2 is jumpered for single stage thermostats). In hookups with more than one relay or contactor, check to see that control circuit wiring is as specified by the appropriate schematic.

4. When all elements and fan are on, break electric power supply to relay and/or contactor by lowering the thermostat set point so that the switch breaks. Check to make sure that all heating stages turn off. The fan should turn off when the elements go off unless the fan is wired for delayed off.