

# BASSET PRODUCTS

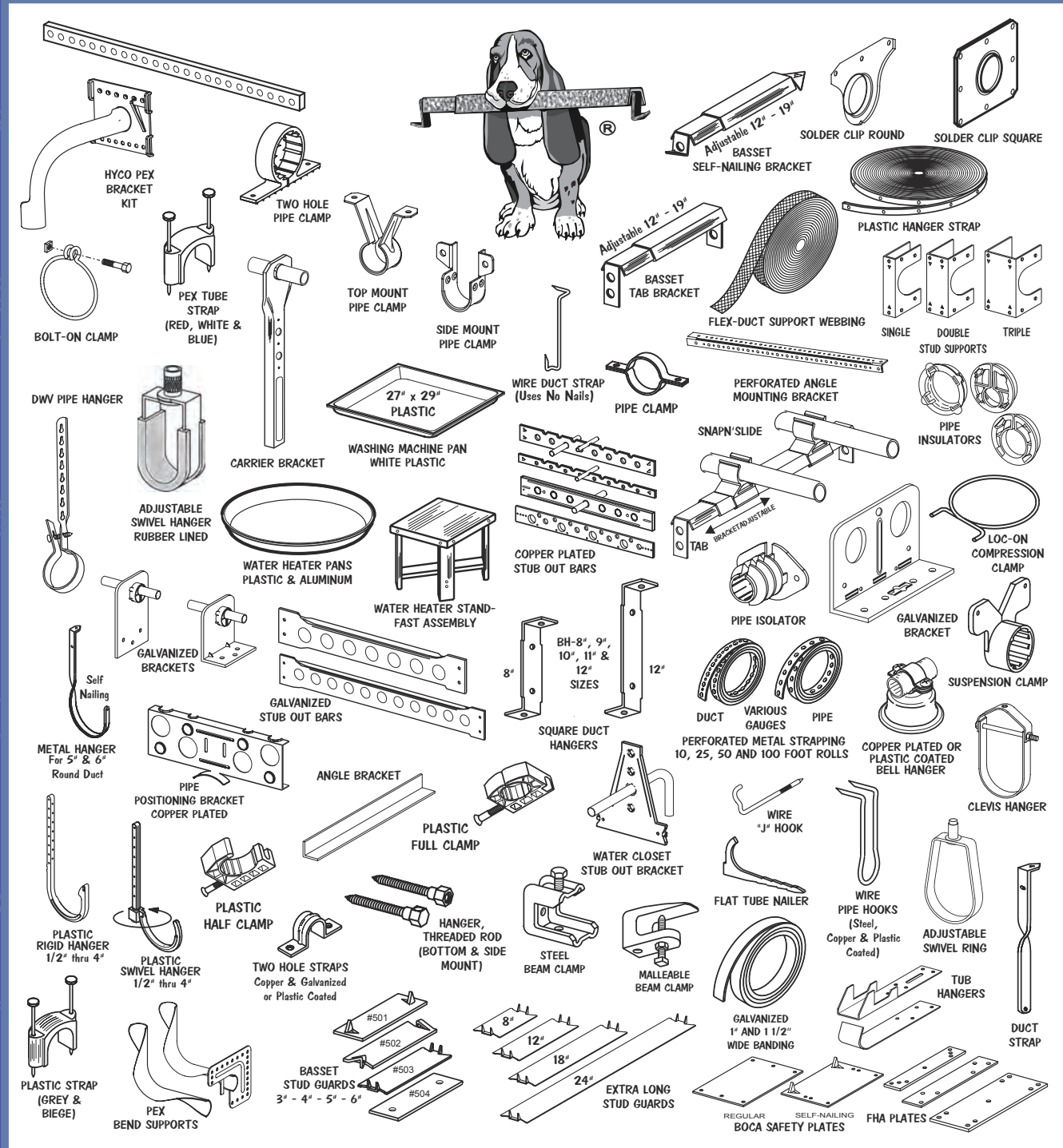

## 2013 FULL LINE CATALOG



### C & S MANUFACTURING CORPORATION

P.O. BOX 736 • 1052 S. NEENAH AVENUE • STURGEON BAY, WI 54235

Phone: 800-959-0374 • Fax: 920-743-7432 • E-mail: [info@BassetProducts.com](mailto:info@BassetProducts.com) • Website: [www.bassetproducts.com](http://www.bassetproducts.com)





## C & S Manufacturing Corporation

C&S Manufacturing Corporation was founded more than 50 years ago in May of 1962 by John D. Collins who worked many previous years as a Heating Contractor in the family heating business. After obtaining a patent on his unique "Basset Bracket" the company was dedicated to the manufacturing and selling of time and labor saving products initially for the HVAC industry. As business grew and new labor saving ideas were developed, the company expanded into the plumbing industry with similar labor saving and code required products. The Basset Product Line of C&S manufacturing is well known in these industries and is now stocked by over 2,500 Plumbing and HVAC wholesalers throughout the country. Basset Products are known for their quality. C&S Manufacturing is committed to the "On Time" shipment of products through the wholesale distribution channel to be available to the contractor when needed.

### Officers and Staff

#### President

James D. Collins

#### General Manager

Steven Ash

#### Sales & Marketing

Luke Collins

#### Office Manager

Terry Bailey

#### Administrative Assistants

Jeannine Courchaine

Jody Wessel

#### Office, Staff & Plant Personnel

C&S Manufacturing employs over 50 people in its Sturgeon Bay facility with an average tenure of nearly a decade.

## C & S Manufacturing Corporation

P.O. Box 736 • Sturgeon Bay, WI 54235 • Phone: 800-959-0374 • Fax: 920-743-7432  
e-mail: [info@BassetProducts.com](mailto:info@BassetProducts.com) • Website: [www.bassetproducts.com](http://www.bassetproducts.com)

# BASSET PRODUCTS ALPHABETICAL INDEX

Banding, Steel, 1" and 1 1/2" wide	200-05	Kit, Tubing, Snap N' Slide	400-01
Bar, Stub-out, HYCO	300-01	Kit, Bracket, Mounting, HYCO, PEX	400-02
Bar, Stub-out, HYCO Supports	300-01	Nail Plates, FHA-28, FHA-40 & FHA-52, Extra Long	200-03
Bar, Stub-out, IS-18, IS-26 & IS-20	300-02	Nail Plate, FHA-100, 1-1/2" wide	200-02
Bar, Stub-out, PS-1, PS-2, MS & MS-500	300-01	Nail Plate, FHA-200, 1-1/2" wide	200-02
Bar, Stub-out, PS-10120 & PS-10126	300-02	Nail Plate, FHA-300, 3" wide, FHA-312, 3-1/2" wide	200-02
Bar, Stub-out, PS-10120-R	300-02	Nail Plate, FHA-400, 1-1/2" wide	200-02
Bar, Stub-out, PS-10720 & PS-10726	300-02	Nail Plate, FHA-500, 5" wide	200-03
Basset, Bracket Self-Nailing	100-01	Nut, Hex, Plain, 3/8"	300-11
Basset, Bracket Tab	100-01	Nut, Hex, Zinc Coated, 3/8"	300-11
Basset, Bracket Tab, Pre-loaded w/screw	100-01	Pan, Washing Machine, Plastic	300-19
Bracket, Adjustable, Self-nailing, PEX	400-01	Pan, Water Heater, Aluminum	300-19
Bracket, Angle	100-01	Pan, Water Heater, Plastic	300-19
Bracket, Angle & Flat, Galvanized	300-04	PEX Sidewinder, w/mounting plate	400-02
Bracket, Carrier	300-03	Pipe Strap, Plastic, w/Preloaded Nails	300-07
Bracket, HYCO PEX	400-02	Plate, BOCA Safety	200-03
Bracket, Perforated, Angle, Mounting	300-05	Plate, Re-enforcing, Stud Support & Mounting Screw	200-03
Bracket, Pipe Positioning, w/Steel Clamp	300-03	Punch, Metal Stud	300-05
Bracket, Slider, Tab, Non-Perforated	200-05	Ring, Extension, Water Closet, Tapered & Flush	300-19
Bracket, Water Closet, Copper Plated	300-03	Ring, Lock, Stainless Steel	300-05
Bracket, Water Closet, Galvanized	300-04	Safety Plates, 1-1/2" Wide	200-01
Clamp, Beam, Malleable Iron	300-10	Stand, Water Heater, Enclosed	300-18
Clamp, Beam, Steel, w/Captive Screw	300-10	Stand, Water Heater, Fast Assembly	300-17
Clamp, Duct, Bolt-on	300-19	Stand, Water Heater, Overhead Support	300-17
Clamp, Duct, Compression, Loc-on	300-19	Stand, Water Heater, Standard	300-18
Clamp, Hose, Worm Gear	300-19	Strapping, Perforated Pipe and Duct	200-04
Clamp, Pipe, Drive Hook, w/Preloaded Nail	300-06	Strap, Tubing, PEX	400-01
Clamp, Pipe, Full Plastic, w/Preloaded Nail	300-06	Strap, Two-Hole	300-07
Clamp, Pipe, Half Plastic, w/Preloaded Nail	300-06	Strap, Water Heater, Quake Resistant	300-18
Clamp, Pipe, Isolator	300-10	Stud Guards, 2" & 3" Wide	200-01
Clamp, Pipe, Plastic, w/Preloaded Nail	300-06	Stud Guards, Extra Long, 1-1/2" wide	200-01
Clamp, Pipe, Riser	300-08	Support, PEX, 90 degree bend	400-02
Clamp, Pipe, Side Mount	300-08	Support, Stud	200-03
Clamp, Pipe, Standard	300-08	Support, Webbing, Flex-Duct	200-05
Clamp, Pipe, Suspension	300-06	Tape, Isolation, Vibration & Sound	100-01
Clamp, Pipe, Top & Side Mount	300-08	Washer, Flat, Plain, 3/8"	300-11
Clamp, Pipe, Two-Hole	300-06	Washer, Flat, Zinc Coated, 3/8"	300-11
Clamp, Tube, Flat Tube Nailer	300-06		
Clamp, Tube, Wire "J" Hook	300-06		
Clamp, Universal Pipe Positioning	200-05		
Clip, Mesh, PEX	400-01		
Clip, Seismic Restraint, Water Heater Stand	300-18		
Clips, Pipe, Solder	300-05		
Coupler, Threaded Rod	300-11		
Hanger, Adjustable, Swivel Ring	300-08		
Hanger, Adjustable, Swivel Ring, Rubber Lined	300-09		
Hanger, Adjustable, Swivel Ring, Felt Lined	300-09		
Hanger, Anchor, Threaded, 90 degree, Wood	300-11		
Hanger, Anchor, Threaded, Straight, Wood	300-11		
Hanger, Bell	300-12		
Hanger, Clevis, Lightweight	300-08		
Hanger, Duct Strap	100-02		
Hanger, DWV (Drain Waste Vent)	300-12		
Hanger, Flex-Duct Saddle	100-02		
Hanger, Plastic Strap	200-05		
Hanger, Rigid	300-13		
Hanger, Round Duct	100-02		
Hanger, Rubber Lined, Sound Isolation	300-09		
Hanger, Square Duct	100-02		
Hanger, Swivel	300-13		
Hanger, Threaded Rod	300-11		
Hanger, Threaded Rod, Extended Length	300-11		
Hanger, Tub, TH-1	300-10		
Hanger, Tub, TH-2	300-10		
Hanger, Wire Duct Strap	100-02		
Hooks, Wire Pipe, 4" & 6" x 9 Ga	300-14		
Hooks, Wire Pipe, 8" x 9 Ga. & 4" x 11 Ga.	300-15		
Hooks, Wire Pipe, 6" x 11 Ga. & 2 1/2" x 11 Ga.	300-16		
Insulators, Pipe, Copper - Plastic -CPVC	300-04		

## BASSET BRACKET, SELF NAILING

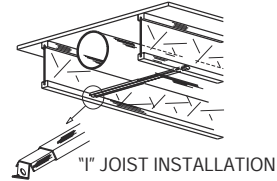
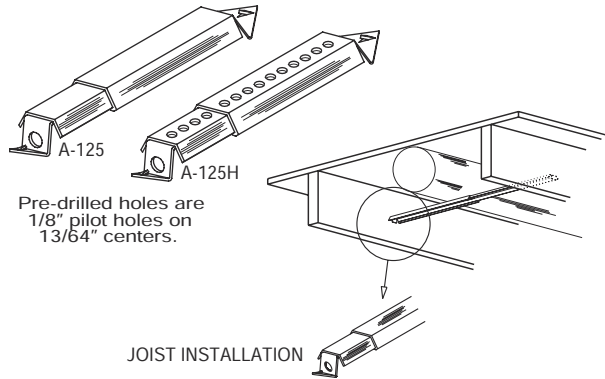

PART NO.	TYPE	LENGTH ADJUST.	MATERIAL	CARTON QUANTITY	WT./CTN. (Lbs.)	LIST PRICE
A-125	Regular	12" to 19"	Galv.	25	5	\$0.7285
A-125H	Regular-Holes	12" to 19"	Galv.	25	5	\$1.0191
A-150	Regular	12" to 19"	Galv.	50	10	\$0.7102
C-125	Regular	12" to 19"	Cu. Plated	25	5	\$1.3172
C-125H	Regular-Holes	12" to 19"	Cu. Plated	25	5	\$1.8444
E-125C	Extra Long	19" to 26"	Cu. Plated	25	9	\$1.6256
E-125G	Extra Long	19" to 26"	Galv.	25	9	\$0.9068

## BASSET BRACKET, TAB

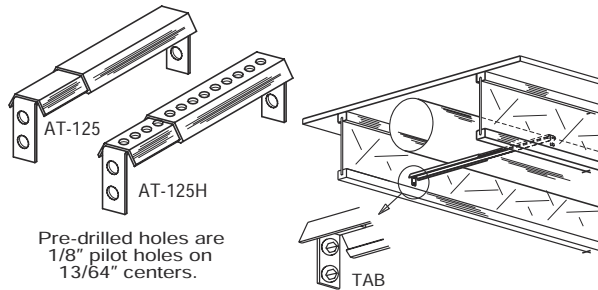

For use where a screw tab is preferred to self-nailing.

PART NO.	TYPE	LENGTH ADJUST.	MATERIAL	CARTON QUANTITY	WT./CTN. (Lbs.)	LIST PRICE
AT-125	Regular	12" to 19"	Galv.	25	5	\$0.7642
AT-125H	Regular-Holes	12" to 19"	Galv.	25	5	\$1.0698
AT-150	Regular	12" to 19"	Galv.	50	10	\$0.7469
CT-125	Regular	12" to 19"	Cu. Plated	25	5	\$1.3308
CT-125H	Regular-Holes	12" to 19"	Cu. Plated	25	5	\$1.8633
ET-125C	Extra Long	19" to 26"	Cu. Plated	25	8	\$1.6272
ET-125G	Extra Long	19" to 26"	Galv.	25	8	\$0.9358

## BASSET BRACKET, TAB, W/ PRE-LOADED SCREWS

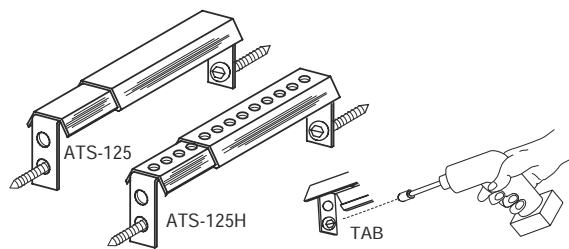

Tab with pre-loaded model allows for easy installation into center section of "1" joist

PART NO.	TYPE	LENGTH ADJUST.	MATERIAL	CARTON QUANTITY	WT./CTN. (Lbs.)	LIST PRICE
ATS-125	Regular	12" to 19"	Galv.	25	5	\$0.8551
ATS-125H	Regular-Holes	12" to 19"	Galv.	25	5	\$1.1974
ATS-150	Regular	12" to 19"	Galv.	50	10	\$0.8551
CTS-125	Regular	12" to 19"	Cu. Plated	25	5	\$1.4220
CTS-125H	Regular-Holes	12" to 19"	Cu. Plated	25	5	\$1.9810
ETS-125C	Extra Long	19" to 26"	Cu. Plated	25	8	\$1.7181
ETS-125G	Extra Long	19" to 26"	Galv.	25	8	\$1.0269

## BRACKET, ANGLE

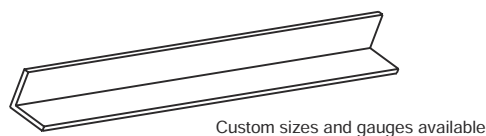

PART NUMBER	MATERIAL	GAUGE	WIDTH/LENGTH	CARTON QUANTITY	WT./CTN. (Lbs.)	LIST PRICE
AB-218	Galv. Steel	22	1-1/2" x 1-1/2" x 18"	50	26	\$0.7514
AB-222	Galv. Steel	24	1-1/2" x 1-1/2" x 18"	50	22	\$0.8585
AB-318	Galv. Steel	24	1" x 3" x 18"	50	29	\$0.9015

# HANGERS

## HANGER, SQUARE DUCT



Available in 8", 9", 10", 11" & 12" lengths.

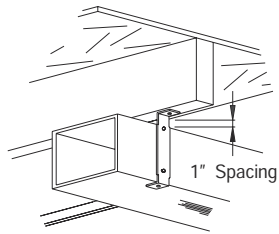

8" to 12" Hanger for standard or larger supply and return runs.  
Used on both Hot Air Supply and Cold Air Return ducts.

PART NUMBER:	BH-8	BH-9	BH-10	BH-11	BH-12
LENGTH:	8"	9"	10"	11"	12"
MATERIAL:	Galv. Steel	Galv. Steel	Galv. Steel	Galv. Steel	Galv. Steel
GAUGE:	18	18	18	18	18
QUANTITY PER CARTON:	100	100	100	100	100
WT. PER CARTON (Lbs.)	10	12	14	15	16
LIST PRICE:	\$0.2984	\$0.3305	\$0.4077	\$0.4510	\$0.4939

## HANGER, ROUND DUCT



Self Nailing

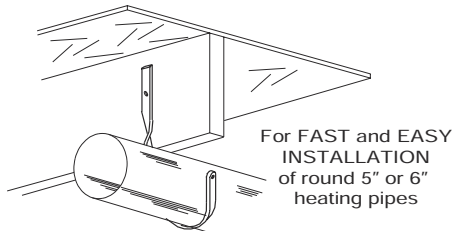

PART NUMBER:	BH-2
DIAMETER:	5" or 6"
MATERIAL:	Galv. Steel
GAUGE:	18
QUANTITY PER CARTON:	50
WT. PER CARTON (Lbs.)	5
LIST PRICE:	\$0.4334

## HANGER, WIRE DUCT STRAP

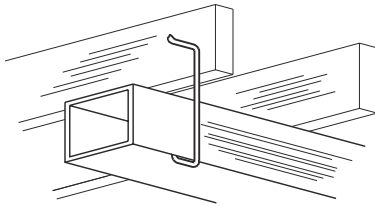

Used for suspending square duct without the use of nails, rivets or screws.

PART NUMBER:	GWS-49	GWS-412
LENGTH:	9"	12"
MATERIAL:	Galv. Steel	Galv. Steel
GAUGE:	9	9
QUANTITY PER CARTON:	100	100
WT. PER CARTON (Lbs.)	6	8
LIST PRICE:	\$0.2253	\$0.2406

## HANGER, DUCT STRAP

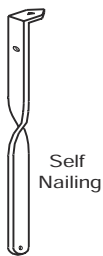

Self Nailing

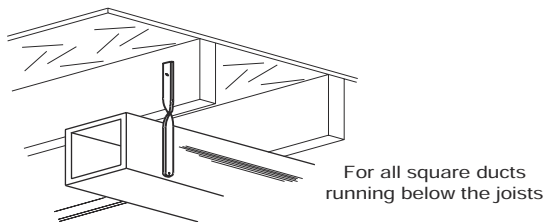

PART NUMBER:	DS-3
MATERIAL:	Galv. Steel
GAUGE:	18
QUANTITY PER CARTON:	100
WT. PER CARTON (Lbs.)	5
LIST PRICE:	\$0.1894

## HANGER, FLEX-DUCT SADDLE

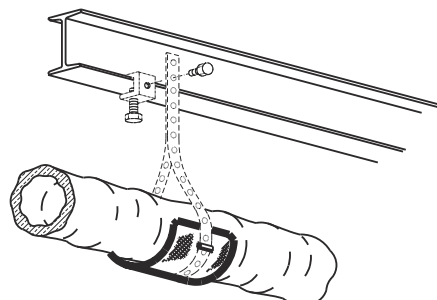
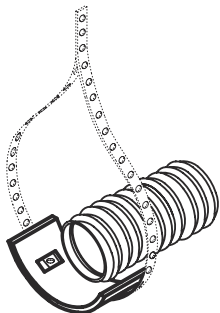

For use in supporting flexible duct work where a metal support is preferred or required over plastic or mesh.

Designed to be used with Basset 3/4" wide strapping. Strapping not included. (See page 200-04)

PART NUMBER:	FDS-9	FDS-12
SIZE:	9" x 4"	12" x 4"
MATERIAL:	Galv. Steel	Galv. Steel
GAUGE:	30	30
QUANTITY PER CARTON:	25	25
WT. PER CARTON (Lbs.)	4	6
LIST PRICE:	\$0.7256	\$0.8775



## STUD GUARDS, 1-1/2" WIDE

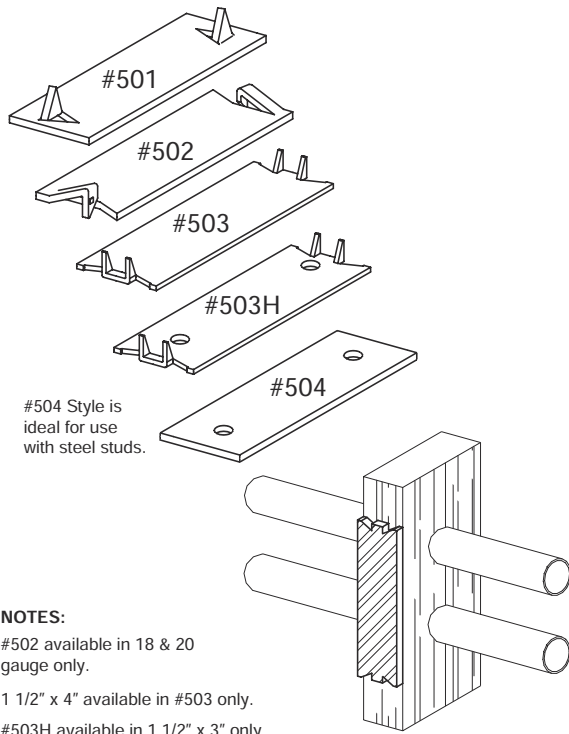

**NOTES:**

#502 available in 18 & 20 gauge only.

1 1/2" x 4" available in #503 only.

#503H available in 1 1/2" x 3" only.

PART NUMBER	GAUGE	WIDTH/LENGTH	CARTON QUANTITY	WT./CTN. (Lbs.)	LIST PRICE
316-501 316-503 316-503H 316-504	16	1-1/2" x 3"	100	8	\$0.1099 \$0.1099 \$0.1099 \$0.1099
318-501 318-502 318-503 318-503H 318-504	18	1-1/2" x 3"	100	6	\$0.0963 \$0.0963 \$0.0963 \$0.0963 \$0.0963
320-501 320-502 320-503 320-503H 320-504	20	1-1/2" x 3"	100	5	\$0.0847 \$0.0847 \$0.0847 \$0.0847 \$0.0847
416-503	16	1-1/2" x 4"	100	10	\$0.1589
418-503	18	1-1/2" x 4"	100	8	\$0.1237
420-503	20	1-1/2" x 4"	100	6	\$0.1021
516-501 516-503 516-504	16	1-1/2" x 5"	100	13	\$0.1695 \$0.1695 \$0.1695
518-501 518-502 518-503 518-504	18	1-1/2" x 5"	100	10	\$0.1322 \$0.1322 \$0.1322 \$0.1322
520-501 520-502 520-503 520-504	20	1-1/2" x 5"	100	8	\$0.1125 \$0.1125 \$0.1125 \$0.1125
616-501 616-503 616-504	16	1-1/2" x 6"	100	16	\$0.1965 \$0.1965 \$0.1965
618-501 618-502 618-503 618-504	18	1-1/2" x 6"	100	10	\$0.1536 \$0.1536 \$0.1536 \$0.1536
620-501 620-502 620-503 620-504	20	1-1/2" x 6"	100	9	\$0.1353 \$0.1353 \$0.1353 \$0.1353

## STUD GUARDS, 2" & 3" WIDE

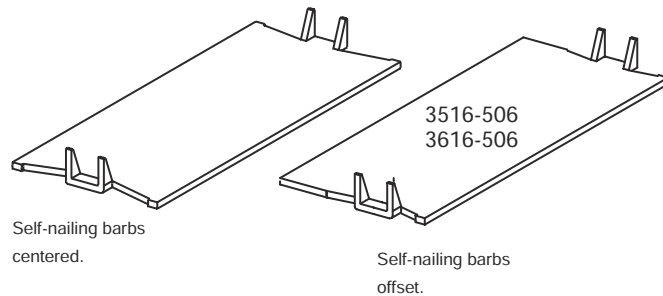

PART NUMBER	GAUGE	WIDTH/LENGTH	CARTON QUANTITY	WT./CTN. (Lbs.)	LIST PRICE
2516-503	16	2" x 5"	100	17	\$0.2114
2518-503	18	2" x 5"	100	14	\$0.1718
2616-503	16	2" x 6"	100	20	\$0.2456
2618-503	18	2" x 6"	100	17	\$0.1920
3316-503	16	3" x 3"	100	16	\$0.2123
3318-503	18	3" x 3"	100	12	\$0.1763
3516-503	16	3" x 5"	100	24	\$0.3176
3518-503	18	3" x 5"	100	20	\$0.2551
3616-503	16	3" x 6"	100	32	\$0.3750
3618-503	18	3" x 6"	100	25	\$0.2791
3516-506	16	3" x 5"	100	24	\$0.3176
3616-506	16	3" x 6"	100	32	\$0.3750

## STUD GUARDS, EXTRA LONG, 1-1/2" WIDE

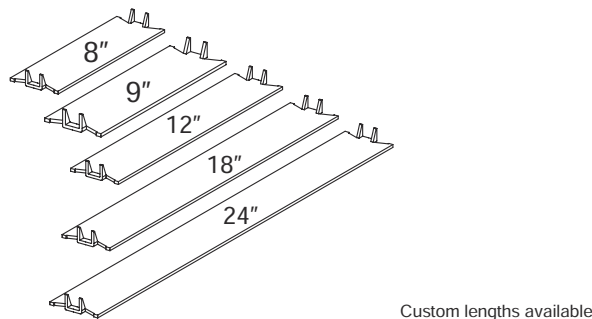

PART NUMBER	GAUGE	WIDTH/LENGTH	CARTON QUANTITY	WT./CTN. (Lbs.)	LIST PRICE
816-503	16	1-1/2" x 8"	50	11	\$0.3924
916-503	16	1-1/2" x 9"	50	12	\$0.4415
1216-503	16	1-1/2" x 12"	50	16	\$0.5076
1816-503	16	1-1/2" x 18"	50	23	\$0.6577
2416-503	16	1-1/2" x 24"	50	32	\$0.9002
818-503	18	1-1/2" x 8"	50	9	\$0.2817
1218-503	18	1-1/2" x 12"	50	13	\$0.3278
1818-503	18	1-1/2" x 18"	50	19	\$0.4614
2418-503	18	1-1/2" x 24"	50	25	\$0.5771
820-503	20	1-1/2" x 8"	50	7	\$0.2076
1220-503	20	1-1/2" x 12"	50	9	\$0.2768
1820-503	20	1-1/2" x 18"	50	14	\$0.4153
2420-503	20	1-1/2" x 24"	50	13	\$0.5538

# SAFETY PLATES

## NAIL PLATE, FHA-100, 1 1/2" WIDE

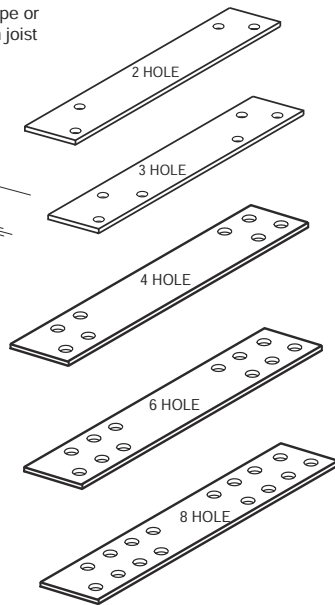
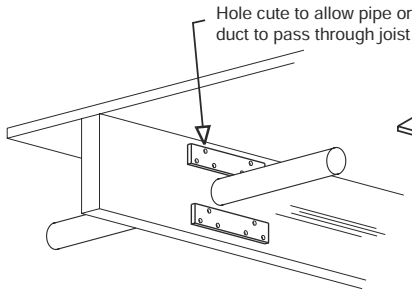

### CEILING OR FLOOR JOIST

- Four reinforcement plates (2 each side of joist) are required for maximum strength.
- 6" FHA plates have only 2 holes on each end.
- 9" FHA plates have 6 and 8 hole configurations stacked vertically.
- "3, 4, 6 or 8 HOLE" noted on plates indicates number of hole each end of plate.
- Include desired number of holes per side at end of part number.
- If number of holes are not specified, 3 holes per side will be shipped.

PART NUMBER	GAUGE	WIDTH/LENGTH	CTY. QTY.	WT./CTN. (Lbs.)	LIST PRICE
FHA-100-612	12	1-1/2" x 6"	50	15	\$0.3283
FHA-100-912	12	1-1/2" x 9"	50	20	\$0.4581
FHA-100-1212	12	1-1/2" x 12"	50	27	\$0.5572
FHA-100-1812	12	1-1/2" x 18"	50	41	\$0.8004
FHA-100-2412	12	1-1/2" x 24"	50	54	\$1.0366
FHA-100-614	14	1-1/2" x 6"	50	10	\$0.2656
FHA-100-914	14	1-1/2" x 9"	50	14	\$0.3683
FHA-100-1214	14	1-1/2" x 12"	50	19	\$0.4412
FHA-100-1814	14	1-1/2" x 18"	50	28	\$0.6119
FHA-100-2414	14	1-1/2" x 24"	50	38	\$0.8004
FHA-100-616	16	1-1/2" x 6"	50	8	\$0.2339
FHA-100-916	16	1-1/2" x 9"	50	12	\$0.3305
FHA-100-1216	16	1-1/2" x 12"	50	15	\$0.4015
FHA-100-1816	16	1-1/2" x 18"	50	23	\$0.5410
FHA-100-2416	16	1-1/2" x 24"	50	30	\$0.6967
FHA-100-2816	16	1-1/2" x 28"	50	35	\$0.8045
FHA-100-618	18	1-1/2" x 6"	50	7	\$0.1982
FHA-100-918	18	1-1/2" x 9"	50	10	\$0.2538
FHA-100-1218	18	1-1/2" x 12"	50	13	\$0.3068
FHA-100-1618	18	1-1/2" x 16"	50	17	\$0.4454
FHA-100-1818	18	1-1/2" x 18"	50	19	\$0.4628
FHA-100-2418	18	1-1/2" x 24"	50	26	\$0.5667
FHA-100-3218	18	1-1/2" x 32"	50	34	\$0.9339

## NAIL PLATE, FHA-200, 1 1/2" WIDE

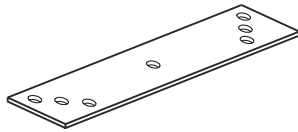

PART NUMBER	GAUGE	WIDTH/LENGTH	CTN. QTY.	WT./CTN. (Lbs.)	LIST PRICE
FHA-200	18	1-1/2" x 18"	50	19	\$0.4628

## NAIL PLATE, FHA-300, 3" WIDE, FHA-312, 3 1/2" WIDE

FHA-300-1216  
FHA-300-1218  
FHA-300-1816  
FHA-300-1818

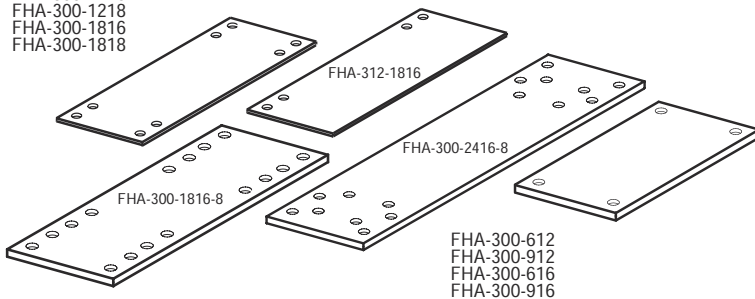

PART NUMBER	GAUGE	WIDTH/LENGTH	CTN. QTY.	WT./CTN. (Lbs.)	LIST PRICE
FHA-300-612	12	3" x 6"	25	13	\$0.5903
FHA-300-912	12	3" x 9"	25	20	\$0.8029
FHA-300-616	16	3" x 6"	25	8	\$0.4650
FHA-300-916	16	3" x 9"	25	12	\$0.6113
FHA-300-1216	16	3" x 12"	25	15	\$0.9522
FHA-300-1816	16	3" x 18"	25	23	\$1.0818
FHA-300-1816-8	16	3" x 18"	25	23	\$1.0818
FHA-312-1816	16	3-1/2" x 18"	25	26	\$1.8032
FHA-300-2416-8	16	3" x 24"	25	30	\$2.1251
FHA-300-1218	18	3" x 12"	25	13	\$0.9015
FHA-300-1818	18	3" x 18"	25	19	\$1.0366

## NAIL PLATE, FHA-400, 1 1/2" WIDE

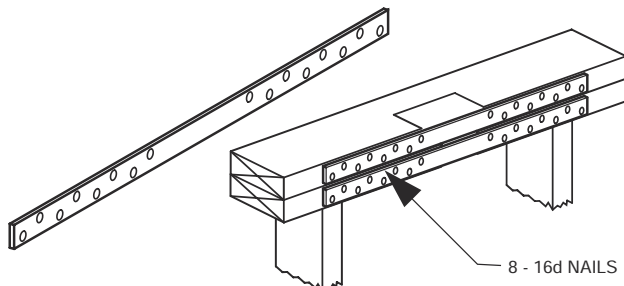

MATERIAL: 16 GA. GALVANIZED STEEL.

### PLUMBING

Available in 18" lengths to reinforce etop plate when notched for vertical DWV installation.

### HEATING

Available in 24" lengths to reinforce top plate when notched for vertical air duct installations.

- Complies with international residential code R602.6.1 "drilling or notching of top plate".
- 8 hole pattern positioned on each end of FHA plate asr equired by code.

PART NUMBER	GAUGE	WIDTH/LENGTH	MAX. NOTCH WIDTH	CTN. QTY.	WT./CTN. (Lbs.)	LIST PRICE
FHA-400-1816	16	1-1/2" x 18"	5-1/2"	50	23	\$0.8029
FHA-400-2416	16	1-1/2" x 24"	11"	50	30	\$1.0626

# SAFETY PLATES, STUD SUPPORTS

## NAIL PLATE, FHA-500, 5" WIDE

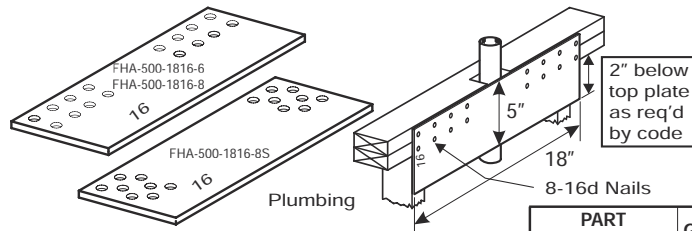

### PLUMBING

- Available in 18" lengths to reinforce top plate when notched for vertical DWV installation.

### HEATING

- Available in 18" lengths to reinforce top plate when notched for vertical air duct installations.
- Complies with International Residential Code R602.6.1, "Drilling or Notching of Top Plate".
- 8 hole pattern positioned on each end of FHA plate as required by codes.
- State or Local code may require all nail holes to be filled.
- All plates stamped with a "16" as required by code.

Meets Boca Code 309.2  
Meets Int'l Code 305.8

MATERIAL: 16 GA. STEEL.

PART NUMBER	GAUGE	WIDTH/LENGTH	HOLES PER SIDE	MAX. NOTCH WIDTH	CARTON QUANTITY	WT./CTN. (Lbs.)	LIST PRICE
FHA-500-1816-6	16	5" x 18"	6	11"	25	37	\$1.9320
FHA-500-1816-8	16	5" x 18"	8	11"	25	37	\$1.9320
FHA-500-1816-8S	16	5" x 18"	8	12"	25	37	\$1.9320

## NAIL PLATE, FHA-28, FHA-40 & FHA-52, EXTRA LONG

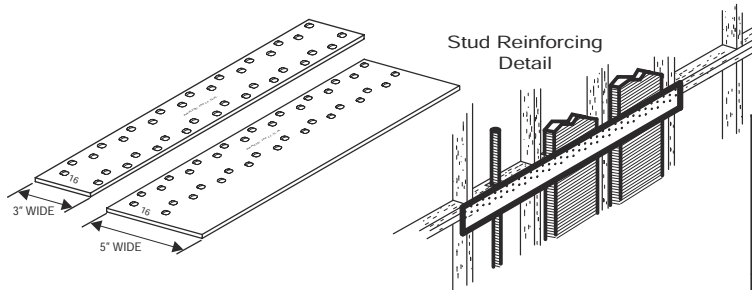

- Mend single, double or triple stud cavities with one plate.
- Custom nail hole pattern available on request.

PART NUMBER	GAUGE	WIDTH/LENGTH	CARTON QUANTITY	WT./CTN. (Lbs.)	LIST PRICE
FHA-28-30	16	3" x 28"	20	29	\$2.9107
FHA-28-50	16	5" x 28"	10	24	\$4.6026
FHA-40-30	16	3" x 40"	15	31	\$4.8027
FHA-40-50	16	5" x 40"	10	34	\$6.8038
FHA-52-30	16	3" x 52"	10	27	\$8.1866
FHA-52-50	16	5" x 52"	5	22	\$9.7146

## PLATE, BOCA SAFETY

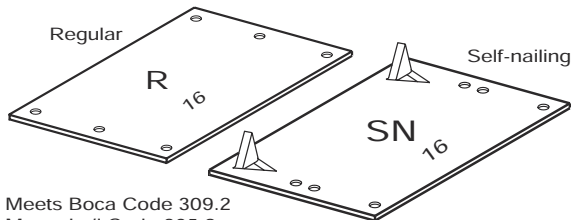

Meets Boca Code 309.2  
Meets Int'l Code 305.8

PART NUMBER	GAUGE	WIDTH/LENGTH	CARTON QUANTITY	WT./CTN. (Lbs.)	LIST PRICE
P58-16-R	16	5" x 8"	50	34	\$0.9660
P58-16SN	16	5" x 8"	50	34	\$0.9660
P66-16-R	16	6" x 6"	50	30	\$1.0304
P68-16SN	16	6" x 8"	50	40	\$1.1806
P68-16-R	16	6" x 8"	50	40	\$1.1806
P3125-16SN	16	3-1/2" x 5"	50	16	\$0.5368
P3126-16SN	16	3-1/2" x 6"	50	17	\$0.6441
P3126-16-R	16	3-1/2" x 6"	50	21	\$0.6441
P3128-16SN	16	3-1/2" x 8"	50	23	\$0.8156
P812-16-R	16	8" x 12"	25	40	\$1.7828

## PLATE, RE-INFORCING, STUD SUPPORT & MOUNTING SCREW

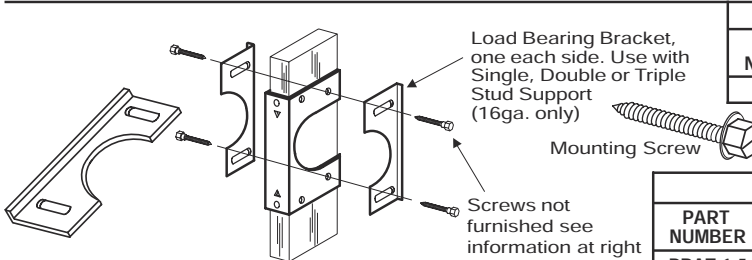

RE-INFORCING PLATE					
PART NUMBER	MATERIAL	GAUGE	CARTON QUANTITY	WT./CTN. (Lbs.)	LIST PRICE
SSRP	Galv.	16	24	2	\$0.3728

MOUNTING SCREW						
PART NUMBER	MATERIAL	SIZE	LENGTH	CARTON QUANTITY	WT./CTN. (Lbs.)	LIST PRICE
PBAT-1-5	Zinc	10-12	3/4"	100	1	\$0.0474

## PLATE, STUD

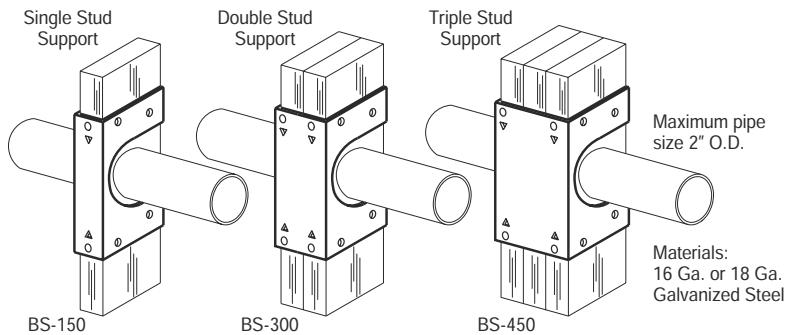

- One hammer blow will sink the two barbs to hold the support for nailing.
- Use anywhere pipe runs through a stud.
- Recommended fasteners:  
10d x 1 1/2" for BS-150 and BS-300;  
10d x 3" for BS-450.

PART NUMBER	SIZE WIDTH	GA.	CARTON QUANTITY	WT./CTN. (Lbs.)	LIST PRICE
BS-150-16	1.51"	16	25	14	\$1.1117
BS-300-16	3.1"	16	25	18	\$1.3308
BS-450-16	4.6"	16	10	11	\$1.8463
BS-150-18	1.51"	18	25	10	\$0.9962
BS-300-18	3.1"	18	25	14	\$1.1871
BS-450-18	4.6"	18	10	8	\$1.6617



# STRAPPING

## STRAPPING, PERFORATED PIPE AND DUCT

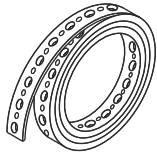

Ductstrap  
(1/4" & 9/64" Holes)

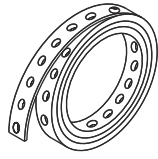

Pipestrap  
(1/4" Holes)

### Basset 3/4" Perforated Strap

- Custom lengths and gauges available.
- Virtually burr free with no sharp edges, the best hanger strap in the industry.

**Note:** All weights approximate due to varying thickness of material.

3/4" x 10" Rolls	10 ROLLS/CARTON	20 GA. BLACK	22 GA. BLACK	24 GA. BLACK	20 GA. GALV.	24 GA. GALV.	28 GA. GALV.	24 GA. COPPER PLATED
	PIPE STRAP PART#	PS10-10-20B	PS10-10-22B	PS10-10-24B	PS10-10-20G	PS10-10-24G	PS10-10-28G	PS10-10-24C
	DUCT STRAP PART#	DS10-10-20B	DS10-10-22B	DS10-10-24B	DS10-10-20G	DS10-10-24G	DS10-10-28G	DS10-10-24C
	WEIGHT/CTN. (Lbs.)	9	7	6	8	5	4	6
	LIST PRICE:	\$1.1570	\$0.9515	\$0.9187	\$1.3426	\$1.0716	\$0.9732	\$2.1431

3/4" x 25" Rolls	6 ROLLS/CARTON	20 GA. BLACK	22 GA. BLACK	24 GA. BLACK	20 GA. GALV.	24 GA. GALV.	28 GA. GALV.	24 GA. COPPER PLATED
	PIPE STRAP PART#	PS25-6-20B	PS25-6-22B	PS25-6-24B	PS25-6-20G	PS25-6-24G	PS25-6-28G	PS25-6-24C
	DUCT STRAP PART#	DS25-6-20B	DS25-6-22B	DS25-6-24B	DS25-6-20G	DS25-6-24G	DS25-6-28G	DS25-6-24C
	WEIGHT/CTN. (Lbs.)	12	11	9	13	8	6	9
	LIST PRICE:	\$2.6014	\$2.5620	\$2.2983	\$2.8259	\$2.6863	\$2.5864	\$5.0998

3/4" x 50" Rolls	1 ROLL/CARTON	20 GA. BLACK	22 GA. BLACK	24 GA. BLACK	20 GA. GALV.	24 GA. GALV.	28 GA. GALV.	24 GA. COPPER PLATED
	PIPE STRAP PART#	PS50-1-20B	PS50-1-22B	PS50-1-24B	PS50-1-20G	PS50-1-24G	PS50-1-28G	PS50-1-24C
	DUCT STRAP PART#	DS50-1-20B	DS50-1-22B	DS50-1-24B	DS50-1-20G	DS50-1-24G	DS50-1-28G	DS50-1-24C
	WEIGHT/CTN. (Lbs.)	4	4	3	5	3	2	3
	LIST PRICE:	\$5.6214	\$4.7846	\$4.5479	\$6.4400	\$5.9489	\$5.4941	\$10.8970

3/4" x 100" Rolls	1 ROLL/CARTON	20 GA. BLACK	22 GA. BLACK	24 GA. BLACK	20 GA. GALV.	24 GA. GALV.	28 GA. GALV.	24 GA. COPPER PLATED
	PIPE STRAP PART#	PS100-1-20B	PS100-1-22B	PS100-1-24B	PS100-1-20G	PS100-1-24G	PS100-1-28G	PS100-1-24C
	DUCT STRAP PART#	DS100-1-20B	DS100-1-22B	DS100-1-24B	DS100-1-20G	DS100-1-24G	DS100-1-28G	DS100-1-24C
	WEIGHT/CTN. (Lbs.)	8	7	5	9	6	5	6
	LIST PRICE:	\$11.5522	\$9.5145	\$9.1325	\$13.3894	\$10.6060	\$9.7692	\$22.5217
3/4" x 100" Bulkpak	5 ROLLS/CARTON	20 GA. BLACK	22 GA. BLACK	24 GA. BLACK	20 GA. GALV.	24 GA. GALV.	28 GA. GALV.	24 GA. COPPER PLATED
	PIPE STRAP PART#	PS100-5-20B	PS100-5-22B	PS100-5-24B	PS100-5-20G	PS100-5-24G	PS100-5-28G	PS100-5-24C
	DUCT STRAP PART#	DS100-5-20B	DS100-5-22B	DS100-5-24B	DS100-5-20G	DS100-5-24G	DS100-5-28G	DS100-5-24C
	WEIGHT/CTN. (Lbs.)	40	35	25	45	30	25	30
	LIST PRICE:	\$11.3628	\$9.3254	\$9.0015	\$13.2038	\$10.5224	\$9.5253	\$22.3544

3/4" x 10" Bulkpak	100 ROLLS/CARTON	20 GA. BLACK	22 GA. BLACK	24 GA. BLACK	20 GA. GALV.	24 GA. GALV.	28 GA. GALV.	24 GA. COPPER PLATED
	PIPE STRAP PART#	PS10-100-20B	PS10-100-22B	PS10-100-24B	PS10-100-20G	PS10-100-24G	PS10-100-28G	PS10-100-24C
	DUCT STRAP PART#	DS10-100-20B	DS10-100-22B	DS10-100-24B	DS10-100-20G	DS10-100-24G	DS10-100-28G	DS10-100-24C
	WEIGHT/CTN. (Lbs.)	76	70	60	76	62	40	57
	LIST PRICE:	\$1.0626	\$0.9134	\$0.8230	\$1.2413	\$1.0005	\$0.9496	\$2.0129

## STRAPPING, PREFORATED DUCT, TRIPLE 'B'

### Basset 5/8" Perforated Triple 'B' Duct Strap

- Light duty, economical duct strap - The Triple 'B'
- 5/8" wide, available in 10', 25', 50' and 100' lengths.
- No need for tin snips to cut to length. Just crease the Triple 'B' at desired separation point, bend back and forth and break.

5/8" x 10' ROLLS

10 ROLLS/CARTON	28 GA. GALV
TRIPLE "B" PART#	DS10-10-28G-58
WEIGHT/CTN. (Lbs.)	3.5
LIST PRICE:	\$0.9002

5/8" x 100' ROLLS

1 ROLL/CARTON	28 GA. GALV
TRIPLE "B" PART#	DS100-1-28G-58
WEIGHT/CTN. (Lbs.)	3.5
LIST PRICE:	\$8.9849

5/8" x 25' ROLLS

6 ROLLS/CARTON	28 GA. GALV
TRIPLE "B" PART#	DS25-6-28G-58
WEIGHT/CTN. (Lbs.)	5
LIST PRICE:	\$2.3982

5/8" x 100' ROLLS

5 ROLLS/CARTON	28 GA. GALV
TRIPLE "B" PART#	DS100-5-28G-58
WEIGHT/CTN. (Lbs.)	20
LIST PRICE:	\$8.5789

5/8" x 50' ROLLS

1 ROLL/CARTON	28 GA. GALV
TRIPLE "B" PART#	DS50-1-28G-58
WEIGHT/CTN. (Lbs.)	1.7
LIST PRICE:	\$5.1550

5/8" x 10' BULKPAK

100 ROLLS/CARTON	28 GA. GALV
TRIPLE "B" PART#	DS10-100-28G-58
WEIGHT/CTN. (Lbs.)	34
LIST PRICE:	\$0.8861

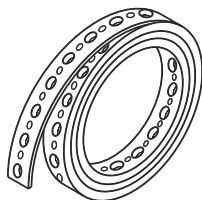

Hanger Strap  
(1/4" & 3/16" Holes)

## BANDING, STEEL, 1" AND 1 1/2" WIDE

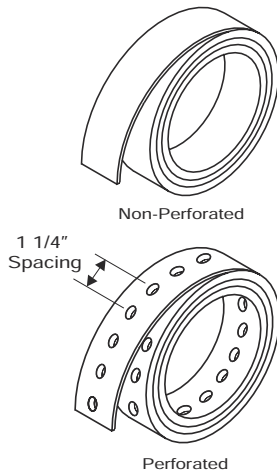

Custom lengths and gauges available.

- \* Available with or without 1/4" bolt holes.
- \* Add (H) at end of part number if bolt holes are required.

1" x 10' ROLLS			ROLLS *		1-1/2" x 80'		1-1/2" x 100'	
<b>PART NUMBER:</b>	<b>BD10-10-30B</b>	<b>BD10-10-30G</b>	<b>PART NUMBER:</b>	<b>BD1-80-26G-112</b>	<b>BD1-100-26G-112</b>			
<b>TYPE:</b>	Non-Perforated	Non-Perforated	<b>TYPE:</b>	w/-w.o. 1/4" Bolt Holes	w/-w.o. 1/4" Bolt Holes			
<b>FINISH:</b>	Black	Galv.	<b>FINISH:</b>	Galv.	Galv.			
<b>GAUGE:</b>	30	30	<b>GAUGE:</b>	26	26			
<b>CARTON QUANTITY:</b>	10 Rolls	10 Rolls	<b>CARTON QUANTITY:</b>	1 Roll	1 Roll			
<b>LENGTH:</b>	10'	10'	<b>LENGTH:</b>	80'	100'			
<b>WEIGHT/CTN (Lbs.)</b>	6	6	<b>WEIGHT/CTN (Lbs.)</b>	8	10			
<b>LIST PRICE:</b>	\$0.9660	\$1.0514	<b>LIST PRICE:</b>	\$16.0856	\$17.7135			
1" x 100' ROLLS			ROLLS *		1-1/2" x 80'		1-1/2" x 100'	
<b>PART NUMBER:</b>	<b>BD1-100-30B</b>	<b>BD1-100-30G</b>	<b>PART NUMBER:</b>	<b>BD1-80-28G-112</b>	<b>BD1-100-28G-112</b>			
<b>TYPE:</b>	Non-Perforated	Non-Perforated	<b>TYPE:</b>	w/-w.o. 1/4" Bolt Holes	w/-w.o. 1/4" Bolt Holes			
<b>FINISH:</b>	Black	Galv.	<b>FINISH:</b>	Galv.	Galv.			
<b>GAUGE:</b>	30	30	<b>GAUGE:</b>	28	28			
<b>CARTON QUANTITY:</b>	1 Roll	1 Roll	<b>CARTON QUANTITY:</b>	1 Roll	1 Roll			
<b>LENGTH:</b>	100'	100'	<b>LENGTH:</b>	80'	100'			
<b>WEIGHT/CTN (Lbs.)</b>	6	6	<b>WEIGHT/CTN (Lbs.)</b>	6	8			
<b>LIST PRICE:</b>	\$9.2961	\$10.4787	<b>LIST PRICE:</b>	\$16.0856	\$17.7135			

## BASSET SLIDER BRACKET, TAB

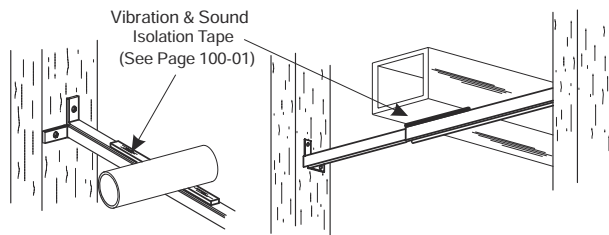

- Adjustable duct and pipe support bracket.
- Supports round and square HVAC ducting, drain pipe and water lines.
- Slides to fit almost any opening.
- Screw tab design enables installation in both steel and wood studs.

PART NUMBER	MATERIAL	LENGTH ADJUSTABLE	CARTON QUANTITY	WT./CTN. (Lbs.)	LIST PRICE
SBT-125	Galv.	14" to 26"	25	8	\$0.9962

## CLAMP, UNIVERSAL PIPE POSITIONING

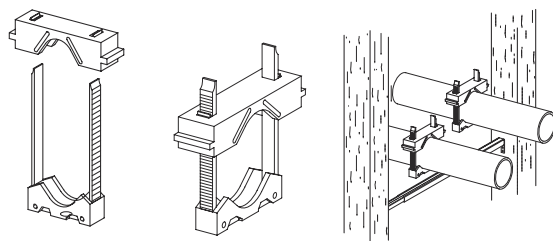

- Clamps fasten any pipe from 1/4" O.D. to 1-1/8" O.D.

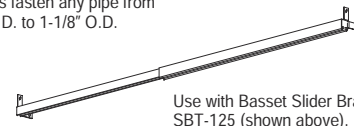

PART NUMBER	DESCRIPTION	WT./CTN. (Lbs.)	CARTON QUANTITY	LIST PRICE
UC-100-5	1-BRIDGE, 1 BASE AND 1-BASE INSERT PER BAG	4	100	\$0.7372

## HANGER, PLASTIC STRAP

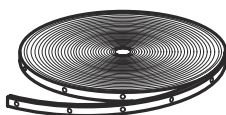

- 3/4" wide x .050" thick, load tested to 125 lbs.
- Flexible, non-conductive, non-abrasive.
- ASTM-A307-77.
- 1/8" holes - 3/4" spacing.
- Supplied in handy dispenser bag.
- Uses: pipe hanger, duct hanger tubing strap, utility strap, etc.
- Cut to length with scissors or utility knife.

3/4" x 100' ROLLS		
<b>PART NUMBER:</b>	<b>PHS-1-5</b>	<b>PHS-20-5</b>
<b>TYPE:</b>	Polyethylene	Polyethylene
<b>THICKNESS:</b>	.050"	.050"
<b>CARTON QUANTITY:</b>	1	20
<b>LENGTH:</b>	100'	100'
<b>WEIGHT/CTN (Lbs.)</b>	2	40
<b>LIST PRICE:</b>	\$7.8663	\$7.8663

## SUPPORT, WEBBING, FLEX-DUCT

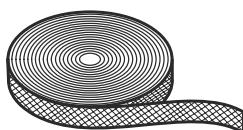

- Polypropylene support webbing for hanging Flex-Duct.
- Lower installation costs reduces time.
- Cut with scissors or utility knife.
- Chemical, electrical and moisture resistant.
- Meets Flame Retardant Standards UL 723 and ASTM E84.
- Tensile Strength: 1 3/4" - 440 lbs. average; 3" - 640 lbs. average.

PART NUMBER:	FSW-1-5	FSW-3-5
<b>TYPE:</b>	Polypropylene	Polypropylene
<b>WIDTH:</b>	1-3/4"	3"
<b>LENGTH:</b>	300'	300'
<b>COLOR:</b>	Black	Black
<b>TENSILE STRENGTH (Lbs.):</b>	440	640
<b>CARTON QUANTITY:</b>	24	8
<b>WEIGHT/CTN (Lbs.)</b>	38	23
<b>LIST PRICE:</b>	\$5.5740	\$11.8440

# STUB-OUT BARS

## PIPE SUPPORTS

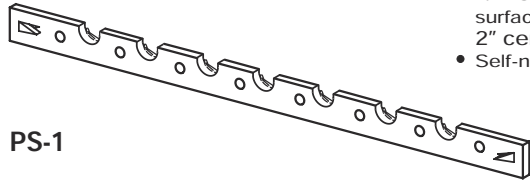

- 1/2" Snap in feature w/extruded surface holds 1/2" tubing on 2" centers.
- Self-nailing, no nails required.

PS-1

PART NUMBER	GA.	LENGTH	FINISH	CARTON QUANTITY	WT./CTN. (Lbs.)	LIST PRICE
PS-1	18	18"	Cu. Plated	50	16	\$1.7152

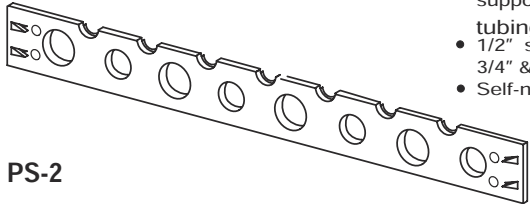

- Snap in & multi-holed support for 1/2", 3/4" & 1" tubing.
- 1/2" snap in on 2" centers, 3/4" & 1" holes on 4" centers.
- Self-nailing, no nails required.

PS-2

PART NUMBER	GA.	LENGTH	FINISH	CARTON QUANTITY	WT./CTN. (Lbs.)	LIST PRICE
PS-2	18	18"	Cu. Plated	50	24	\$1.9836

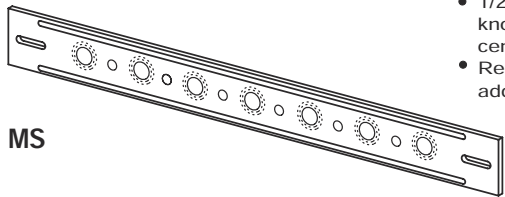

- Multi-size Fits 1/2", 3/4" & 1" tubing.
- 1/2" hole with 3/4" & 1" knockout holes on 2" centers.
- Re-inforcing ribs for additional strength.

MS

PART NUMBER:	MS-18	MS-20	MS-26
LENGTH:	18"	20"	26"
GAUGE:	18	18	18
FINISH:	Cu. Plated	Cu. Plated	Cu. Plated
CARTON QUANTITY:	50	50	50
WT. PER CARTON (Lbs.)	18	23	29
LIST PRICE:	\$1.7152	\$1.8066	\$2.3141

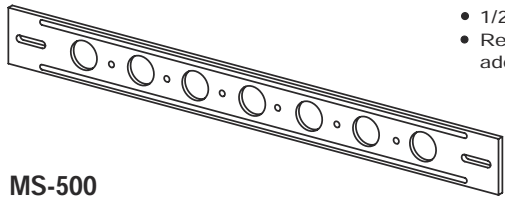

- 1/2" holes on 2" centers.
- Re-inforcing ribs for additional strength.

MS-500

PART NUMBER:	MS-500-18	MS-500-20	MS-500-26
LENGTH:	18"	20"	26"
GAUGE:	18	18	18
FINISH:	Cu. Plated	Cu. Plated	Cu. Plated
CARTON QUANTITY:	50	50	50
WT. PER CARTON (Lbs.)	18	23	29
LIST PRICE:	\$1.6175	\$1.8891	\$2.2669

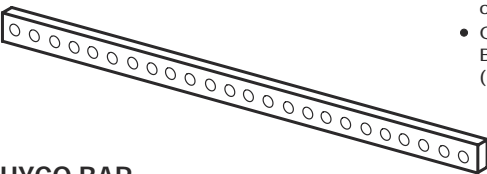

- 3/16" holes on 3/4" centers.
- Can be used with HYCO Bar supports. (See below)

HYCO BAR

PART NUMBER:	HY-118	HY-120	HY-126
LENGTH:	18"	20"	26"
GAUGE:	14	14	14
FINISH:	Galv.	Galv.	Galv.
CARTON QUANTITY:	100	100	100
WT. PER CARTON (Lbs.)	24	28	34
LIST PRICE:	\$0.4003	\$0.4540	\$0.5348

## HYCO BAR SUPPORTS

- Use supports with HYCO bar for copper, PEX or CPVC tubing.

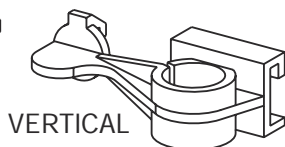
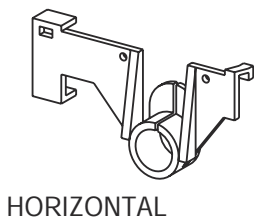

PART NUMBER	DESCRIPTION	CARTON QUANTITY	WT./CTN. (Lbs.)	LIST PRICE
HY12H-5	Insulator, Horizontal, 1/2"	50	1	\$0.3407
HY34H-5	Insulator, Horizontal, 3/4"	50	1	\$0.4025
HY12V-5	Insulator, Vertical, 1/2"	50	1	\$0.3407
HY34V-5	Insulator, Vertical, 3/4"	50	1	\$0.4025
HY12H-CPVC-5	Insulator, Horizontal, 1/2", CPVC	50	1	\$0.4520
HY34H-CPVC-5	Insulator, Horizontal, 3/4", CPVC	50	1	\$0.5452

## PIPE SUPPORTS

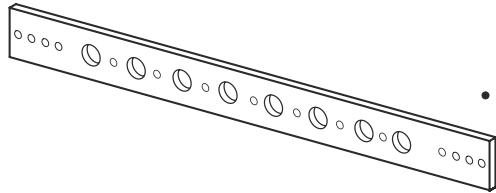

- 1/2" holes on 2" centers.

PS-10120  
PS-10126

PART NUMBER:	PS-10120	PS-10126
LENGTH:	20"	26"
GAUGE:	16	16
FINISH:	Cu. Plated	Cu. Plated
CARTON QUANTITY:	50	50
WT. PER CARTON (Lbs.)	18	28
LIST PRICE:	\$1.8193	\$2.4895

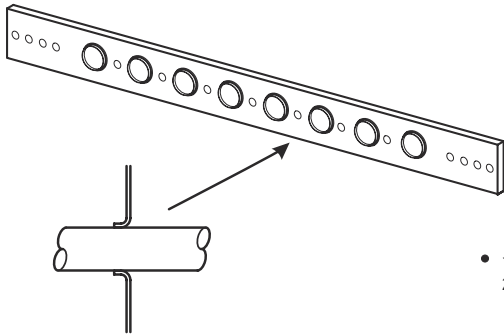

- 1/2" extruded holes on 2" centers.

PS-10120-R

PART NUMBER:	PS-10120-R
LENGTH:	20"
GAUGE:	16
FINISH:	Cu. Plated
CARTON QUANTITY:	25
WT. PER CARTON (Lbs.)	10
LIST PRICE:	\$1.8193

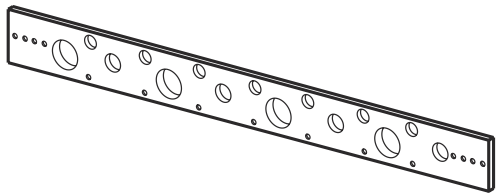

- 1/2" holes on 2" centers.
- 3/4" holes on 4" centers.
- 1" holes on 4" centers.

PS-10720  
PS-10726

PART NUMBER:	PS-10720	PS-10726
LENGTH:	20"	26"
GAUGE:	16	16
FINISH:	Cu. Plated	Cu. Plated
CARTON QUANTITY:	50	50
WT. PER CARTON (Lbs.)	21	26
LIST PRICE:	\$1.9953	\$2.4895

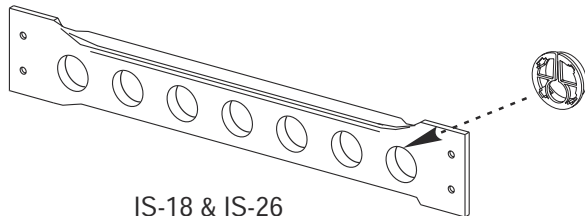

IS-18 & IS-26

- Accepts plastic inserts 1/2", 3/4" & 1".
- Hole size 1-11/32" on 2" centers.

IS-20



1/2" 3/4"  
For CPVC Pipes



1/2" 3/4" 1"  
For Copper and Poly Pipes

### AVAILABLE INSERTS

See Page 300-04 for plastic insert ordering information.

PART NUMBER:	IS-18	IS-20	IS-26
LENGTH:	18"	20"	26"
GAUGE:	20	14	20
FINISH:	Galv.	Galv.	Galv.
CARTON QUANTITY:	50	50	50
WT. PER CARTON (Lbs.)	20	30	32
LIST PRICE:	\$1.4642	\$1.8483	\$1.7238

# BRACKETS

## BRACKET, CARRIER

2 MODELS AVAILABLE

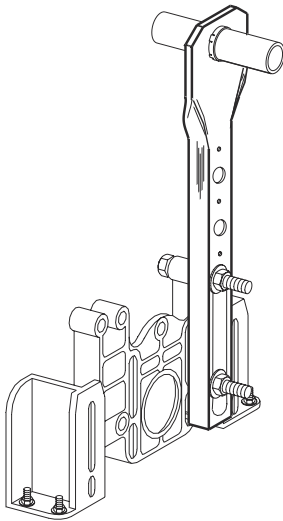

Properly positions water pipe for flush valve, 26 1/2" above floor and 4 1/2" offset from center of carrier.

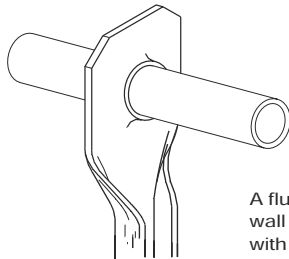

**BCB-C**  
Copper plated bracket with extruded hole for direct soldering of 1" copper pipe.

A flush valve positioning bracket for wall hung closets. Bracket attaches with closet carrier bolts.

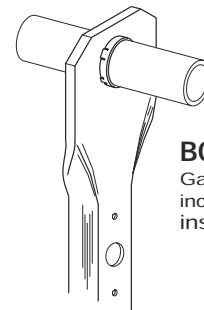

**BCB-G**  
Galvanized bracket includes 1" plastic insert.

PART NUMBER:	BCB-C	BCB-G
MATERIAL:	Steel	Steel
FINISH:	Cu. Plated	Galvanized
GAUGE:	16	16
CARTON QUANTITY:	10	10
WT. PER CARTON (Lbs.)	10	10
LIST PRICE:	\$6.8694	\$6.4400

## BRACKET, PIPE POSITIONING, W/ STEEL CLAMP

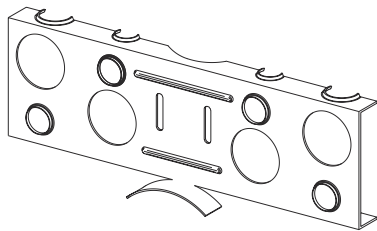

This copper plated bracket attaches to the vertical or horizontal waste or vent pipe. Provides both snap-in or extruded holes for both 1/2" or 3/4" copper supply pipes on 4" & 8" centers. Bracket also provides 1-11/32" holes to accommodate plastic inserts for 1/2", 3/4" & 1" pipes on 4" & 8" centers.

Bracket fits nicely within 4" partitioned walls to position water supply lines for lavatories, sinks and other fixtures.

PART NUMBER:	PPB
MATERIAL:	Steel
FINISH:	Cu. Plated
GAUGE:	16
CARTON QUANTITY:	25
WT. PER CARTON (Lbs.)	16
LIST PRICE:	\$4.4653

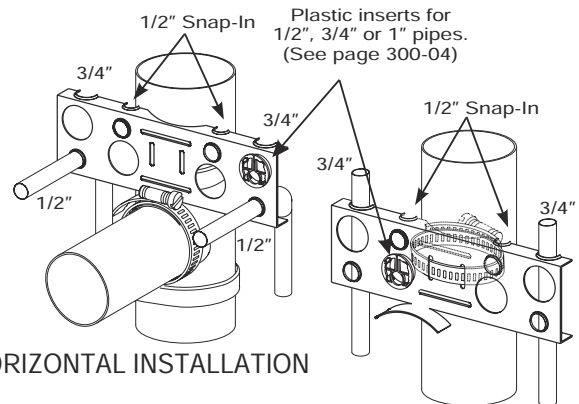

HORIZONTAL INSTALLATION

VERTICAL INSTALLATION

Steel clamp provided with bracket

## BRACKET, COPPER PLATED, WATER CLOSET

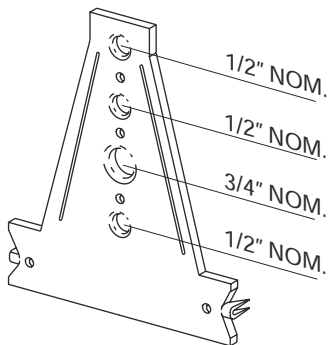

Positions both 1/2" & 3/4" tubing at just the right height above the floor while also functioning as a nail plate. All holes are extruded for maximum soldering surface.

Water Closet bracket, WCB-M, provided without self-nailer for use on metal studs.

Bracket also functions as nail plate

Basset Water Closet brackets are ideal when stubbing out service lines for both regular and low boy toilets or hose bibbs.

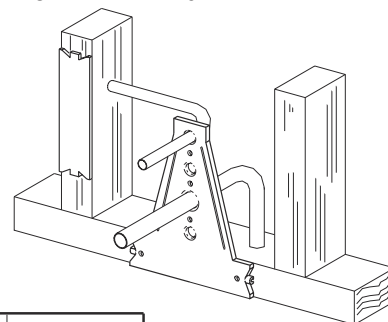

PART NUMBER	GA.	DESCRIPTION	MATERIAL	CARTON QUANTITY	WT./CTN. (Lbs.)	LIST PRICE
WCB	16	Water Closet Bracket, Self-Nailer	Cu. Plated Steel	25	8	\$2.4199
WCB-M	16	Water Closet Bracket, Holes only	Cu. Plated Steel	25	8	\$2.4199



# BRACKETS, INSULATORS

## BRACKET, GALVANIZED, WATER CLOSET

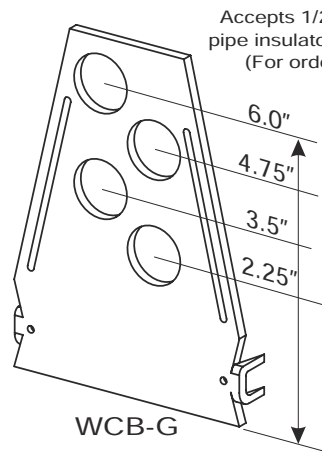

Accepts 1/2", 3/4" & 1" plastic pipe insulators for 1-11/32" hole.  
(For ordering information, see below)

For Copper and Poly Pipes

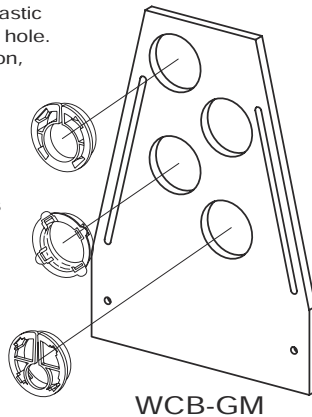

2.25", 3.5", 4.75" & 6.0" hole center lines accommodate low boy toilet, hose bibb and standard toilet supply lines.

16 gauge with built in stud guard.

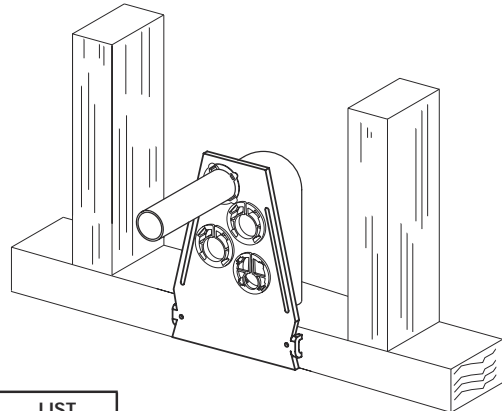

Water Closet bracket, WCB-GM, provided without self-nailer for use on metal studs.

Use pipe insulators shown below

PART NUMBER	GA.	DESCRIPTION	MATERIAL	CARTON QUANTITY	WT./CTN. (Lbs.)	LIST PRICE
WCB-G	16	Water Closet Bracket, Self-nailer	Galv.	25	8	\$0.8823
WCB-GM	16	Water Closet Bracket, Self-nailer	Galv.	25	8	\$0.8823

## BRACKET, GALVANIZED, ANGLE & FLAT

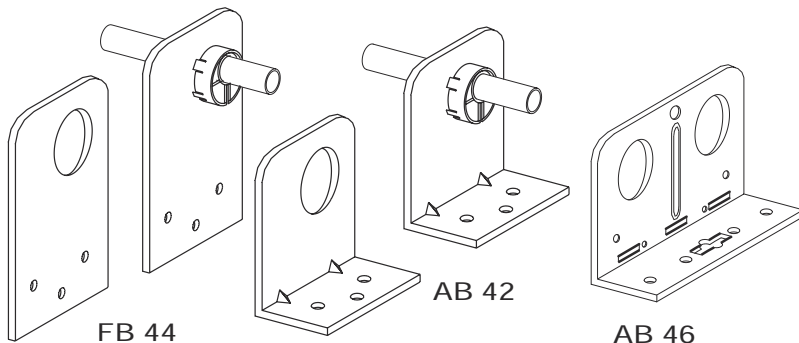

AB 46 provides multiple mounting holes and slots for installation flexibility.

AB 46 supports dual lines of copper, PEX and CPVC tubing.

All models accept 1/2", 3/4" & 1" plastic pipe insulators for 1-11/32" hole. (For ordering information, see below)

PART NUMBER:	AB 42	AB 46	FB 44
TYPE:	Angle	Angle	Flat
HOLE SIZE:	1-11/32"	1-11/32"	1-11/32"
MATERIAL:	Steel	Steel	Steel
FINISH:	Galv.	Galv.	Galv.
GAUGE:	21	21	21
CARTON QUANTITY:	100	25	100
WT. PER CARTON (Lbs.)	8	5	8
LIST PRICE:	\$0.3650	\$0.6912	\$0.3220

Use pipe insulators shown below

## INSULATORS, PIPE - COPPER - POLY - CPVC

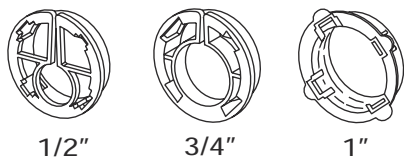

1/2" 3/4" 1"

For Copper and Poly Pipes

Flame Retardant Insulators Available By Special Order

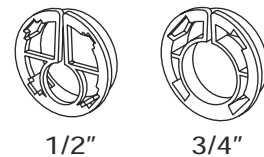
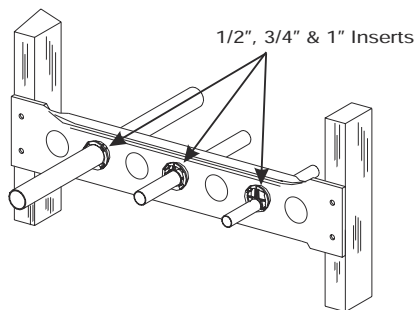

1/2" 3/4"

For CPVC Pipes

Glueable Inserts, CPVC Compatible

PART NUMBER	SIZE	HOLE SIZE	CARTON QUANTITY	WT./CTN. (Lbs.)	LIST PRICE
PI500-5	1/2"	1-11/32"	100	1	\$0.1573
PI750-5	3/4"	1-11/32"	100	1	\$0.1573
PI1000-5	1"	1-11/32"	100	1	\$0.1573

PART NUMBER	SIZE	HOLE SIZE	CARTON QUANTITY	WT./CTN. (Lbs.)	LIST PRICE
PI12CPVC-5	1/2"	1-11/32"	100	1	\$0.1748
PI34CPVC-5	3/4"	1-11/32"	100	1	\$0.1865

# BRACKETS, CLIPS

## PUNCH, METAL STUD

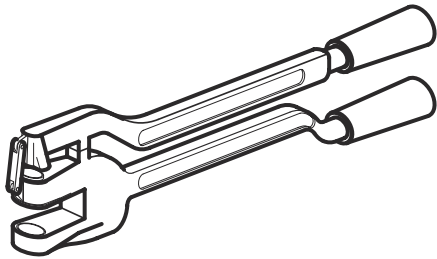

- Cuts 20 GA. steel , 1 - 11/32" hole size.
- Heavy duty with extended throat.
- One year warranty against defects or breakage.

PART NUMBER	HOLE SIZE	UNITS/ CTN.	WT./ EACH	LIST PRICE
ETSP-5	1-11/32"	1	6Lbs.	\$258.46

## BRACKET, PERFORATED, ANGLE, MOUNTING

1/2" x 1/2" x 16" Long

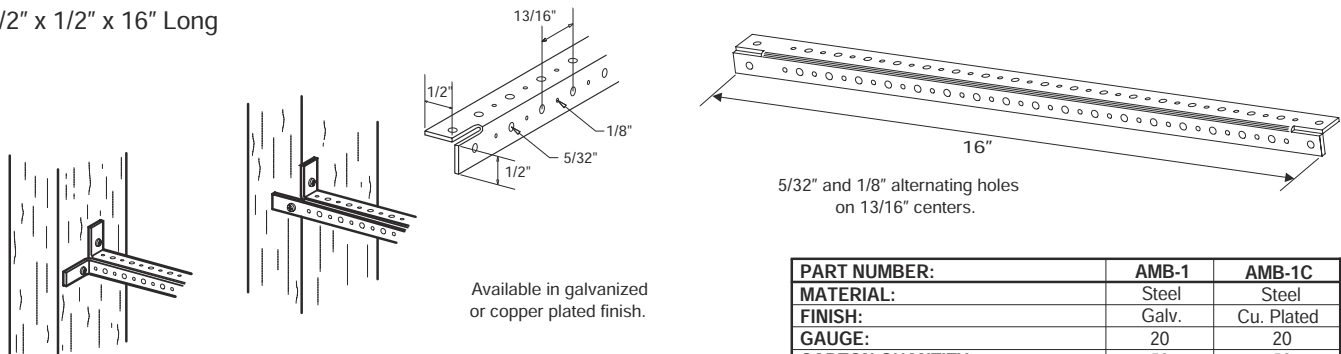

Available in galvanized or copper plated finish.

PART NUMBER:	AMB-1	AMB-1C
MATERIAL:	Steel	Steel
FINISH:	Galv.	Cu. Plated
GAUGE:	20	20
CARTON QUANTITY:	50	50
WT. PER CARTON (Lbs.)	16	16
LIST PRICE:	\$0.7943	\$1.7874

## CLIPS, PIPE, SOLDER

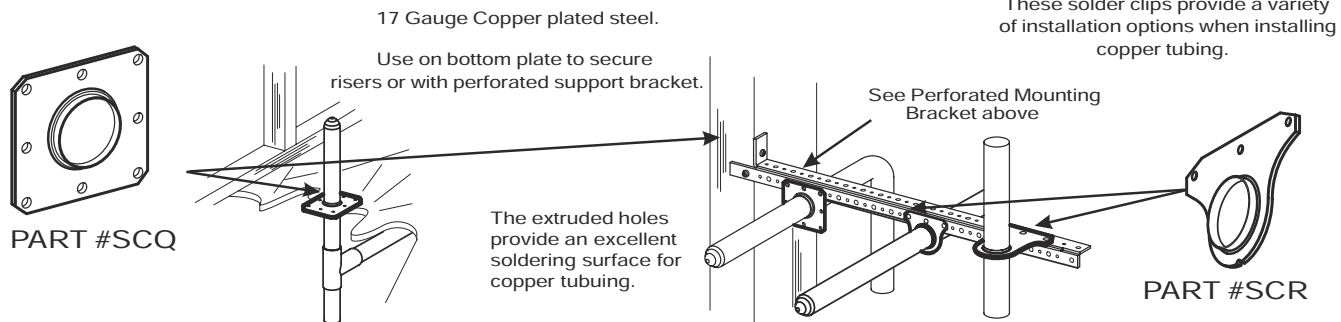

PART NUMBER	SIZE	MATERIAL	CARTON QUANTITY	WT./CTN. (Lbs.)	LIST PRICE
SCQ-12	1/2"	Cu. Plated	100	5	\$0.3821
SCQ-34	3/4"	Cu. Plated	100	5	\$0.5216
SCQ-100	1"	Cu. Plated	100	4	\$0.5365

PART NUMBER	SIZE	MATERIAL	CARTON QUANTITY	WT./CTN. (Lbs.)	LIST PRICE
SCR-12	1/2"	Cu. Plated	100	3	\$0.3434
SCR-34	3/4"	Cu. Plated	100	3	\$0.4830

## RING, LOCK, STAINLESS STEEL

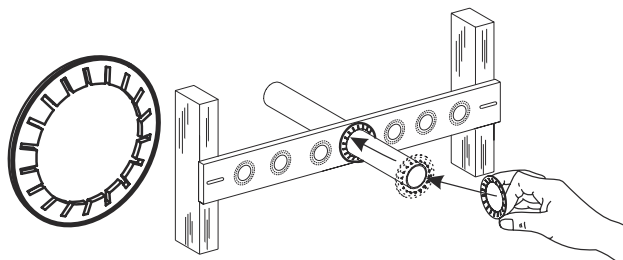

- Slides over and secures copper tubing into place.
- Prevents movement of tubing in backward direction.
- Fits 1/2" copper tubing.

PART NUMBER	SIZE	MATERIAL	CARTON QUANTITY	WT./CTN. (Lbs.)	LIST PRICE
SSLR	1/2"	Stainless Steel	100	1	\$0.1073

## PIPE CLAMP, DRIVE HOOK W/ PRE-LOADED NAIL



- Pre-loaded ringed shank nail.
- Affixes 1/2", 5/8" & 3/4" CTS nominal tube and 1/2" Schedule 40 IPS pipe.
- Ideal for flexible gas tube.

PART NUMBER	DESCRIPTION	SIZE	CARTON QUANTITY	WT./CTN. (Lbs.)	LIST PRICE
DH12-34-5	1/2" & 3/4" Drive hook w/ nail holds 1/2" & 3/4" tubing	1/2" & 3/4"	100	2	\$0.1124

## PIPE CLAMP, FULL PLASTIC, W/ PRE-LOADED NAIL

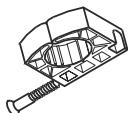

- Pre-loaded ringed shank nail.
- Provides 1/2" stand-off.

PART NUMBER	DESCRIPTION	SIZE	CARTON QUANTITY	WT./CTN. (Lbs.)	LIST PRICE
BSC-1P-5	1/2" Plastic full clamp w/ nail	1/2"	100	2	\$0.1169
BSC-2P-5	3/4" Plastic full clamp w/ nail	3/4"	50	2	\$0.1528
BSC-3P-5	1" Plastic full clamp w/ nail	1"	25	1	\$0.4315

## PIPE CLAMP, HALF PLASTIC, W/ PRE-LOADED NAIL

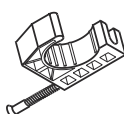

- Pre-loaded ringed shank nail.
- Install clamps in alternating directions to insure secure piping installation

PART NUMBER	DESCRIPTION	SIZE	CARTON QUANTITY	WT./CTN. (Lbs.)	LIST PRICE
BHS-1P-5	1/2" Plastic half clamp w/ nail	1/2"	100	1	\$0.0674
BHS-2P-5	3/4" Plastic half clamp w/ nail	3/4"	100	2	\$0.1016
BHS-3P-5	1" Plastic half clamp w/ nail	1"	50	1	\$0.2877

## PIPE CLAMP, PLASTIC, W/ PRE-LOADED NAIL



- Pre-loaded ringed shank nail.
- Nail lock tube into hanger.

PART NUMBER	DESCRIPTION	SIZE	CARTON QUANTITY	WT./CTN. (Lbs.)	LIST PRICE
TS-12-5	1/2" Plastic tube strap w/ nail	1/2"	100	2	\$0.1438
TS-34-5	3/4" Plastic tube strap w/ nail	3/4"	50	2	\$0.2427

## PIPE CLAMP, SUSPENSION

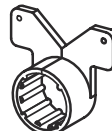

- A versatile clamp made of durable, non-corrosive polypropylene.
- Split design snaps over copper, CPVC, PEX or polybutene isolating it from mounting surface.
- Use on top or under joist or rafter
- For both wood or metal framework
- Eliminates noise

PART NUMBER	SIZE	MATERIAL	CARTON QUANTITY	WT./CTN. (Lbs.)	LIST PRICE
SC-1P-5	1/2"	Plastic	100	1	\$0.1573
SC-2P-5	3/4"	Plastic	50	1	\$0.1798
SC-3P-5	1"	Plastic	50	1	\$0.2248

## PIPE CLAMP, TWO-HOLE

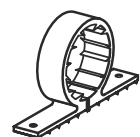

- Plastic 2-Hole clamp secures copper, CPVC and PEX to both wood and metal framework.
- Split design for maximum flexibility.
- Made of durable non-corrosive polypropylene.
- Eliminate snoise.

PART NUMBER	SIZE	MATERIAL	CARTON QUANTITY	WT./CTN. (Lbs.)	LIST PRICE
TPC-1P-5	1/2"	Plastic	100	1	\$0.1686
TPC-2P-5	3/4"	Plastic	50	1	\$0.1910
TPC-3P-5	1"	Plastic	50	1	\$0.2360

## TUBE CLAMP, FLAT TUBE NAILER

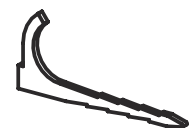

- FTNC, FTNZ & FTNPC fits both 1/2" & 3/4" copper, steel or plastic tubing.
- FTNC1, FTNZ1 & FTNPC1 fit 1" copper, steel or plastic tubing.

PART NUMBER	MATERIAL	CARTON QUANTITY	WT./CTN. (Lbs.)	LIST PRICE
FTNC	Cu. Plated	100	2	\$0.1030
FTNC1	Cu. Plated	100	2	\$0.0966
FTNZ	Zinc Plated	100	2	\$0.2104
FTNZ1	Zinc Plated	100	3	\$0.2258
FTNPC	Plastic Coated	100	3	\$0.2477
FTNPC1	Plastic Coated	100	3	\$0.3467

## TUBE CLAMP, WIRE "J" HOOK



- 8 Gauge Wire
- 1/2" & 3/4" copper or zinc plated or plastic coated.

PART NUMBER	SIZE	MATERIAL	CARTON QUANTITY	WT./CTN. (Lbs.)	LIST PRICE
12CJH	1/2"	Cu. Plated	100	2	\$0.1135
34CJH	3/4"	Cu. Plated	100	2	\$0.1146
12ZJH	1/2"	Zinc Plated	100	2	\$0.1135
34ZJH	3/4"	Zinc Plated	100	2	\$0.1146
12PCJH	1/2"	Plastic Coated	100	2	\$0.2037
34PCJH	3/4"	Plastic Coated	100	2	\$0.2046

# STRAPS

## STRAP, TWO-HOLE

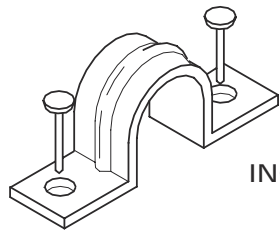

NAILS INCLUDED

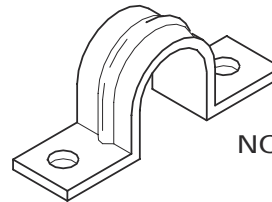

NAILS NOT INCLUDED

Galvanized Finish

PART NUMBER	PIPE SIZE	WT./CTN. (Lbs.)	CARTON QUANTITY	LIST PRICE	PART NUMBER	PIPE SIZE	WT./CTN. (Lbs.)	CARTON QUANTITY	LIST PRICE
14THS-GWN	1/4"	2	100	\$0.0445	14THS-GNN	1/4"	1	100	\$0.0357
38THS-GWN	3/8"	2	100	\$0.0481	38THS-GNN	3/8"	1	100	\$0.0373
12THS-GWN	1/2"	2	100	\$0.0610	12THS-GNN	1/2"	2	100	\$0.0503
34THS-GWN	3/4"	4	100	\$0.0761	34THS-GNN	3/4"	3	100	\$0.0619
1THS-GWN	1"	5	100	\$0.1607	1THS-GNN	1"	4	100	\$0.1467
114THS-GWN	1-1/4"	4	50	\$0.2114	114THS-GNN	1-1/4"	3	50	\$0.2008
112THS-GWN	1-1/2"	4	50	\$0.2313	112THS-GNN	1-1/2"	4	50	\$0.2203
2THS-GWN	2"	5	50	\$0.2429	2THS-GNN	2"	4	50	\$0.2321
212THS-GWN	2-1/2"	4	25	\$0.5185	212THS-GNN	2-1/2"	4	25	\$0.5078
3THS-GWN	3"	5	25	\$0.6628	3THS-GNN	3"	5	25	\$0.6522
4THS-GWN	4"	6	25	\$1.1361	4THS-GNN	4"	6	25	\$1.1256

Copper Plated Finish

PART NUMBER	COPPER TUBING SIZE	WT./CTN. (Lbs.)	CARTON QUANTITY	LIST PRICE	PART NUMBER	COPPER TUBING SIZE	WT./CTN. (Lbs.)	CARTON QUANTITY	LIST PRICE
14THS-CWN	1/4"	1	100	\$0.0795	14THS-CNN	1/4"	1	100	\$0.0687
38THS-CWN	3/8"	2	100	\$0.0754	38THS-CNN	3/8"	1	100	\$0.0644
12THS-CWN	1/2"	2	100	\$0.1326	12THS-CNN	1/2"	1	100	\$0.1217
34THS-CWN	3/4"	2	100	\$0.1364	34THS-CNN	3/4"	2	100	\$0.1254
1THS-CWN	1"	4	100	\$0.1862	1THS-CNN	1"	3	100	\$0.1715
114THS-CWN	1-1/4"	4	100	\$0.2526	114THS-CNN	1-1/4"	4	100	\$0.2381
112THS-CWN	1-1/2"	4	50	\$0.3377	112THS-CNN	1-1/2"	3	50	\$0.3232
2THS-CWN	2"	5	50	\$0.4314	2THS-CNN	2"	5	50	\$0.4169

Plastic Coated Finish

PART NUMBER	PIPE SIZE	WT./CTN. (Lbs.)	CARTON QUANTITY	LIST PRICE	PART NUMBER	PIPE SIZE	WT./CTN. (Lbs.)	CARTON QUANTITY	LIST PRICE
14THS-PCWN	1/4"	2	100	\$0.1734	14THS-PCNN	1/4"	1	100	\$0.1646
38THS-PCWN	3/8"	2	100	\$0.1768	38THS-PCNN	3/8"	1	100	\$0.1662
12THS-PCWN	1/2"	3	100	\$0.1900	12THS-PCNN	1/2"	1	100	\$0.1791
34THS-PCWN	3/4"	4	100	\$0.2047	34THS-PCNN	3/4"	3	100	\$0.1908
1THS-PCWN	1"	5	100	\$0.2429	1THS-PCNN	1"	4	100	\$0.2285
114THS-PCWN	1-1/4"	6	50	\$0.4302	114THS-PCNN	1-1/4"	7	50	\$0.4193
112THS-PCWN	1-1/2"	5	50	\$0.4341	112THS-PCNN	1-1/2"	4	50	\$0.4231
2THS-PCWN	2"	6	50	\$0.4678	2THS-PCNN	2"	5	50	\$0.4573
212THS-PCWN	2-1/2"	5	25	\$0.6903	212THS-PCNN	2-1/2"	5	25	\$0.6796
3THS-PCWN	3"	6	25	\$0.8345	3THS-PCNN	3"	6	25	\$0.8240
4THS-PCWN	4"	7	25	\$1.3079	4THS-PCNN	4"	7	25	\$1.2971

## PIPE STRAP, PLASTIC, W/ PRE-LOADED NAILS

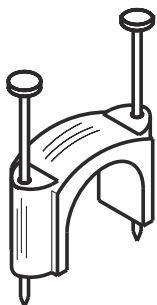

PIPE/TUBING SIZES:

1/2" - Plastic Water Pipe and Copper Tubing: 0.625" Dia.

3/4" - Plastic Water Pipe and Copper Tubing: 0.880" Dia.

1" - Plastic Water Pipe and Copper Tubing: 1.16" Dia.

PART NUMBER	SIZE	COLOR	CARTON QUANTITY	WT./CTN. (Lbs.)	LIST PRICE
P-500-5	1/2"	Tan	100	2	\$0.0809
P-750-5	3/4"	Tan	50	2	\$0.1349
P-1000-5	1"	Grey	25	1	\$0.1865

## CLAMP, PIPE, TOP MOUNT & SIDE MOUNT

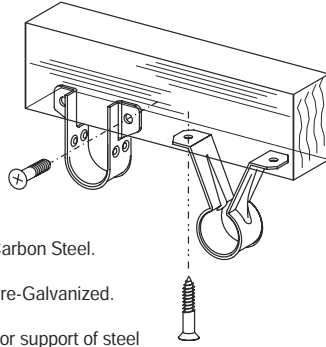
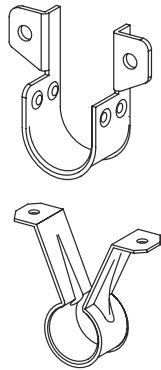

MATERIAL: Carbon Steel.  
 FINISH: Pre-Galvanized.  
 APPLICATION: For support of steel pipe, cast iron pipe and conduit risers.

PART NO.	PIPE SIZE (I.P.S.)	MAX. SPACING	CARTON QUANTITY	WT./CTN. (Lbs.)	LIST PRICE
SIDE MOUNT BRACKET					
SMS-34-5	3/4"	5-1/2'	100	9	\$0.4495
SMS-1-5	1"	6'	100	10	\$0.4720
SMS-114-5	1-1/4"	61/2'	100	11	\$0.5169
SMS-112-5	1-1/2"	7'	100	12	\$0.5844
SMS-2-5	2"	8'	100	13	\$0.6068
TOP MOUNT BRACKET					
SOS-34-5	3/4"	5-1/2'	100	10	\$0.4720
SOS-1-5	1"	6'	100	12	\$0.4945
SOS-114-5	1-1/4"	61/2'	100	14	\$0.5844
SOS-112-5	1-1/2"	7'	100	16	\$0.5844
SOS-2-5	2"	8'	100	18	\$0.6068

## CLAMP, RISER



MATERIAL: Carbon Steel.  
 FINISH: Black or Zinc plated.  
 APPLICATION: For support of steel pipe, cast iron pipe conduit risers.

PART NO. ZINC	PART NO. BLACK	PIPE SIZE	MAX. LOAD (Lbs.)	CARTON QUANTITY	WT./CTN. (Lbs.)	ZINC LIST PRICE	BLACK PRICE
RCGS-1-5	RCHS-1-5	1"	255	25	24	\$3.3263	\$2.7644
RCGS-114-5	RCHS-114-5	1-1/4"	255	25	25	\$3.3263	\$2.7644
RCGS-112-5	RCHS-112-5	1-1/2"	255	25	26	\$3.3937	\$2.8543
RCGS-2-5	RCHS-2-5	2"	255	25	28	\$5.1018	\$2.8543
RCGS-212-5	RCHS-212-5	2-1/2"	390	25	26	\$5.0344	\$4.1579
RCGS-3-5	RCHS-3-5	3"	530	20	35	\$5.9109	\$3.9556
RCGS-4-5	RCHS-4-5	4"	810	15	33	\$6.4953	\$6.4953
RCGS-6-5	RCHS-6-5	6"	1570	10	33	\$10.4953	\$8.0461

## CLAMP, PIPE, STANDARD

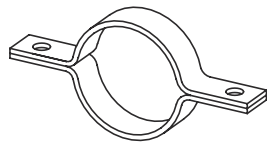

MATERIAL: Carbon steel.  
 FINISH: Black.  
 APPLICATION: Support of non-insulated pipe lines.

PART NO. BLACK	PIPE SIZE	MAX. LOAD (Lbs.)	CARTON QUANTITY	WT./CTN. (Lbs.)	LIST PRICE
PCS-1-5	1"	255	25	9	\$2.4273
PCS-114-5	1-1/4"	255	25	10	\$2.5172
PCS-112-5	1-1/2"	255	25	10	\$2.5846
PCS-2-5	2"	390	25	28	\$4.2703
PCS-212-5	2-1/2"	390	15	19	\$4.5400
PCS-3-5	3"	530	15	21	\$4.9220
PCS-4-5	4"	810	15	34	\$7.2594
PCS-6-5	6"	1570	10	54	\$14.8785

## HANGER, CLEVIS, LIGHTWEIGHT

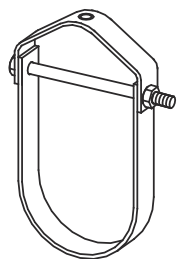

MATERIAL: Carbon steel.  
 FINISH: Black or Zinc plated. Also available with plastic coated lower saddle.  
 APPLICATION: Suspending non-insulated pipe lines.

PART NO. ZINC	PART NO. BLACK	PIPE SIZE	ROD DIA.	MAX. LOAD (Lbs.)	CARTON QUANTITY	WT./CTN. (Lbs.)	ZINC LIST PRICE	BLACK LIST PRICE
CHLG-12-5	CHLS-12-5	1/2"	3/8"	150	50	5	\$1.0114	\$0.4270
CHLG-34-5	CHLS-34-5	3/4"	3/8"	250	50	6	\$1.0339	\$0.6743
CHLG-1-5	CHLS-1-5	1"	3/8"	250	50	8	\$1.1013	\$1.1238
CHLG-114-5	CHLS-114-5	1-1/4"	3/8"	250	50	10	\$1.2361	\$1.1013
CHLG-112-5	CHLS-112-5	1-1/2"	3/8"	250	50	11	\$1.3485	\$1.5283
CHLG-2-5	CHLS-2-5	2"	3/8"	250	50	12	\$1.5508	\$1.2811
CHLG-212-5	CHLS-212-5	2-1/2"	1/2"	350	25	10	\$2.8768	\$2.2026
CHLG-3-5	CHLS-3-5	3"	1/2"	350	25	11	\$3.0566	\$2.5622
CHLG-4-5	CHLS-4-5	4"	5/8"	400	20	12	\$4.6748	\$3.9331

## HANGER, ADJUSTABLE SWIVEL RING

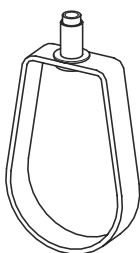

MATERIAL: Carbon steel.  
 FINISH: Zinc plated.  
 APPLICATION: Designed for suspending insulated pipe (with lining) or non-insulated pipe allowing for vertical adjustment.

PART NO. ZINC	PIPE OR TUBING SIZE	ROD DIA.	MAX. LOAD (Lbs.)	CARTON QUANTITY	WT./CTN. (Lbs.)	LIST PRICE
SRS-12-5	1/2"	3/8"	400	100	10	\$0.4270
SRS-34-5	3/4"	3/8"	400	100	11	\$0.4270
SRS-1-5	1"	3/8"	400	100	11	\$0.4046
SRS-114-5	1-1/4"	3/8"	400	100	12	\$0.5169
SRS-112-5	1-1/2"	3/8"	400	100	12	\$0.5169
SRS-2-5	2"	3/8"	400	100	12	\$0.5619
SRS-212-5	2-1/2"	3/8"	600	50	8	\$1.0563
SRS-3-5	3"	3/8"	600	50	13	\$1.0788
SRS-4-5	4"	3/8"	1000	20	5	\$1.1687



# HANGERS

## HANGER, ADJUSTABLE SWIVEL RING, RUBBER LINED

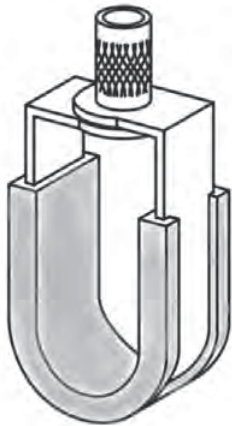

- Rubber lined for copper pipe.
- Corrosion resistant.
- Provides sound and vibration isolation.
- Mounts on 3/8" threaded rod.
- 360 degree movement allows for mounting from wall, ceiling or floor.
- Height adjustable.
- Fast & Easy installation.
- Temperature rating -50 F to + 220 F.
- Moisture proof.

MATERIAL: Carbon steel

FINISH: Zinc Plated

APPLICATION: Suspending non-insulated copper tubing or pipe.

PART NO. GALV.	PIPE CPS	ROD	MAX. LOAD (Lbs.)	CARTON QUANTITY	WT./CTN. (Lbs.)	LIST PRICE
SRR-12-5	1/2"	3/8"	400	100	10	\$0.6068
SRR-34-5	3/4"	3/8"	400	100	10	\$0.6068
SRR-100-5	1"	3/8"	400	100	13	\$0.6518
SRR-114-5	1-1/4"	3/8"	400	100	14	\$0.7192
SRR-112-5	1-1/2"	3/8"	400	100	15	\$0.7417
SRR-200-5	2"	3/8"	400	100	17	\$0.8765
SRR-212-5	2-1/2"	3/8"	600	50	9	\$1.7531
SRR-300-5	3"	3/8"	600	50	9	\$1.8205
SRR-400-5	4"	3/8"	1000	20	6	\$2.0452

## HANGER, ADJUSTABLE SWIVEL RING, FELT LINED



- Felt lined for copper pipe.
- Corrosion resistant.
- Provides sound and vibration isolation.
- Mounts on 3/8" threaded rod.
- 360 degree movement allows for mounting from wall, ceiling or floor.
- Height adjustable.
- Fast & Easy installation.

MATERIAL: Carbon steel.

FINISH: Zinc plated.

APPLICATION: Suspending non-insulated copper tubing or pipe.

PART NO. GALV.	PIPE CPS	ROD	MAX. LOAD (Lbs.)	CARTON QUANTITY	WT./CTN. (Lbs.)	LIST PRICE
SRF-12-5	1/2"	3/8"	400	100	10	\$0.6068
SRF-34-5	3/4"	3/8"	400	100	10	\$0.6068
SRF-100-5	1"	3/8"	400	100	13	\$0.6518
SRF-114-5	1-1/4"	3/8"	400	100	14	\$0.7192
SRF-112-5	1-1/2"	3/8"	400	100	15	\$0.7417
SRF-200-5	2"	3/8"	400	100	17	\$0.8091
SRF-212-5	2-1/2"	3/8"	600	50	9	\$1.5283
SRF-300-5	3"	3/8"	600	50	9	\$1.6182
SRF-400-R	4"	3/8"	1000	20	6	\$1.8654

## HANGER, RUBBER LINED, SOUND ISOLATION

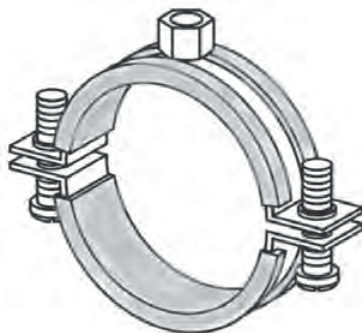

- Provides superior noise reduction and reduced pipe vibration.
- Mounts on 3/8" threaded rod.
- 360 degree movement allows for mounting from wall, ceiling or floor.
- Captive rubber lining prevents slipping.
- Adjustable to accommodate varying pipe sizes.
- Eliminates metal to metal contact.

MATERIAL: Carbon steel.

FINISH: Zinc plated.

APPLICATION: Designed for suspending insulated pipe (with lining) or non-insulated pipe allowing for vertical adjustment.

PART NO. GALV.	PIPE IPS	PIPE CPS	ROD	MAX. LOAD (Lbs.)	CARTON QUANTITY	WT./CTN. (Lbs.)	LIST PRICE
SC-100A-5	1/4"	3/8"	3/8"-16	337	100	16	\$1.0339
SC-101A-5	3/8"	1/2"	3/8"-16	337	100	16	\$1.0339
SC-102A-5	1/2"	3/4"	3/8"-16	337	100	17	\$1.0788
SC-103A-5	3/4"	1"	3/8"-16	337	100	18	\$1.1013
SC-104A-5	1"	1-1/4"	3/8"-16	337	100	20	\$1.2361
SC-105A-5	1-1/4"	1-1/2"	3/8"-16	337	100	24	\$1.3036
SC-106A-5	1-1/2"	2"	3/8"-16	337	100	24	\$1.6632
SC-107A-5	1 3/4"	-----	3/8"-16	337	100	24	\$1.9104
SC-108A-5	2"	2-1/2"	3/8"-16	337	100	28	\$1.9329
SC-109A-5	2-1/2"	3"	3/8"-16	337	50	23	\$2.3374
SC-110A-5	3"	-----	3/8"-16	711	50	27	\$2.5397
SC-111A-5	-----	4"	3/8"-16	711	50	34	\$3.0566
SC-112A-5	4"	-----	3/8"-16	711	20	27	\$3.3937

# CLAMPS, HANGERS, SUPPORTS

## FASTNER, STRUT LOCKING SLIDE BOLT

**STEP ONE - INSERT**  
Insert Slide Bolt retainer tab into strut channel end as shown and slide to desired location.

**STEP TWO - SLIDE**  
Slide Bolt retainer tab to desired location on strut.

**STEP THREE - ROTATE**  
Rotate Slide Bolt retainer tab 1/4 turn to align tab across the inside width of the strut.

**STEP FOUR - LOCK**  
When Slide Bolt is properly positioned, hand tighten upper nut to lock in place. Then tighten with wrench or channel locks.

**STRUT LOCKING SLIDE BOLT**

- Pre-assembled (3/8" threaded stud, U-shaped washer, hex nut, sliding nut with spring)
- No parts to assemble or lose
- Fits all conventional support strut
- Bolts made of zinc-plated steel
- Simply insert and twist...tighten nut and you're done.

PART NUMBER	DESCRIPTION	MATERIAL	CTN. QTY.	WT./CTN. (Lbs.)	LIST PRICE
LSB-1US-5	Strut Locking Slide Bolt, 3/8" x 1" Long	Zinc Plated	25	5	\$0.7642

See page 300-11 for Threaded Rod Hanger and Threaded Rod Coupler accessories.

## HANGER, TUB

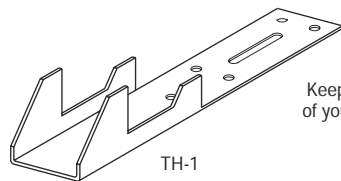

20 GA. GALVANIZED STEEL

Keeps the rear corner of your bath tub in line.

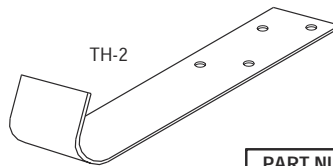

12 GA. GALVANIZED STEEL

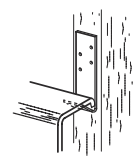

PART NUMBER	TH-1	TH-2
CARTON QUANTITY	100	100
WT. PER CARTON (lbs.)	16	22
LIST PRICE	\$1.0304	\$0.4176

## CLAMP, BEAM

### MALLEABLE IRON - W/ LOCK NUT

MATERIAL: Malleable iron.  
FINISH: Plain.

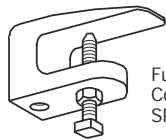

Furnished with hardened steel cup point set screw with locknut. Complies with Fed. Spec. WW-H-H-171 (Type 19) and MSS SP-69 (Type 19).

PART NUMBER	CARTON QUANTITY	WT./CTN. (Lbs.)	LIST PRICE
380-5 (3/8")	100	33	\$1.1013
500-5 (1/2")	100	34	\$1.7980

### STEEL - W/ CAPTIVE SCREW

MATERIAL: Brite Zinc Plated Steel.  
LOAD LIMIT: 100Lbs.

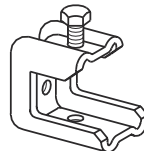

Furnished with 1/4"-20 x 1" Hex Screw Assures the most dependable universal support for heavy piping, conduit, hanger rods, etc. Has 1/4" holes for threaded rod on top, rear and bottom.

PART NUMBER	CARTON QUANTITY	WT./CTN. (Lbs.)	LIST PRICE
BBC-5	50	7	\$1.3935

## CLAMP, PIPE ISOLATOR

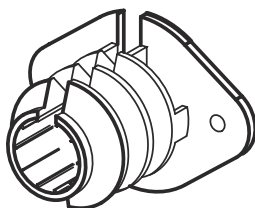

- Reduces water line noise and vibration.
- Split desing allows for use after piping run.
- Designed to work in both 1-3/8" or 1-11/32" holes for wood or metal studs

PART NUMBER	DESCRIPTION	SIZE	CARTON QUANTITY	WT./CTN. (Lbs.)	LIST PRICE
IPC-12-5	1/2" Isolator Pipe Clamp	1/2"	50	1.2	\$0.2023
IPC-34-5	3/4" Isolator Pipe Clamp	3/4"	50	1.1	\$0.2248
IPC-100-5	1" Isolator Pipe Clamp	1"	50	0.9	\$0.2472

# HANGER MOUNTING HARDWARE

## HANGER, THREADED ROD, BOTTOM MOUNT, WOOD



• Self drilling & threading into wood.

MATERIAL: Commercial grade carbon steel.  
FINISH: Electro-galvanized zinc.

PART NUMBER	ROD SIZE	SHANK DIA.	SHANK LENGTH	EMBEDDING DEPTH	MAX. PIPE SIZE	MAX LOAD (Lbs.)	CARTON QUANTITY	WT./CTN. (Lbs.)	LIST PRICE
RF-BM138-5	3/8"-16	1/4"	1"	1"	3"	1050	100	2	\$0.4495
RF-BM238-5	3/8"-16	1/4"	2"	2"	3"	1050	100	2	\$0.4495
RF-BM21238-5	3/8"-16	5/16"	2 1/2"	2 1/2"	4"	1050	100	3	\$1.5733

## HANGER, THREADED ROD, SIDE MOUNT, WOOD

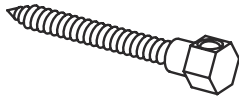

• Self-drilling & threading into wood.

MATERIAL: Commercial grade carbon steel.  
FINISH: Electro-galvanized zinc.

PART NUMBER	ROD SIZE	SHANK DIA.	SHANK LENGTH	EMBEDDING DEPTH	MAX. PIPE SIZE	MAX LOAD (Lbs.)	CARTON QUANTITY	WT./CTN. (Lbs.)	LIST PRICE
RF-SM238-5	3/8"-16	1/4"	2"	2"	3"	1050	25	2	\$0.5619

## HANGER, THREADED ROD

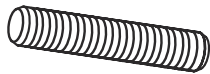

MATERIAL: Low carbon steel.  
FINISH: Electro-galvanized.

PART NUMBER	THREADED STUD SIZE	CARTON QUANTITY	WT./CTN. (Lbs.)	LIST PRICE
TS-238-5	3/8"-16 x 2"	100	5	\$0.1349
TS-338-5	3/8"-16 x 3"	100	7	\$0.1798
TS-438-5	3/8"-16 x 4"	100	10	\$0.2248
TS-638-5	3/8"-16 x 6"	100	14	\$0.4046
TS-1238-5	3/8"-16 x 12"	100	28	\$0.7192

## HANGER, THREADED ROD, EXTENDED LENGTH

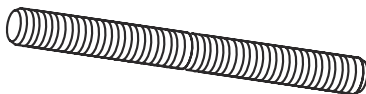

MATERIAL: Low carbon steel.  
FINISH: Plain or Zinc coated.

PART NUMBER	THREADED STUD SIZE	CARTON QUANTITY	WT./CTN. (Lbs.)	LIST PRICE
TRP-5	3/8"-16 x 6'	25	44	\$2.5812
TRZ-5	3/8"-16 x 6'	25	44	\$3.1134

## COUPLER, THREADED ROD

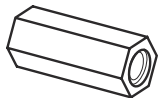

• Provides a means of joining two lengths of threaded rod.

FINISH: Electro-galvanized.

PART NUMBER	ROD SIZE	CARTON QUANTITY	WT./CTN. (Lbs.)	LIST PRICE
TRC-38118-5	3/8"-16	25	1	\$0.1573

## HARDWARE, HANGER MOUNTING SYSTEM

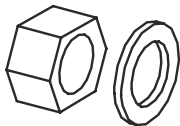

• FINISH: Zinc Coated or Plain.

PART NUMBER	DESCRIPTION	FINISH	CARTON QUANTITY	WT./CTN. (Lbs.)	LIST PRICE
HP-5	3/8"-16 HEX, NUT, GRADE 2	PLAIN	100	1.6	\$0.0597
HZ-5	3/8"-16 HEX, NUT, GRADE 2	ZINC COATED	100	1.6	\$0.0674
WP-5	3/8"-16 WASHER, FLAT, USS	PLAIN	100	1.5	\$0.0661
WZ-5	3/8"-16 WASHER, FLAT, USS	ZINC COATED	100	1.5	\$0.0629

## HANGER MOUNTING SYSTEM

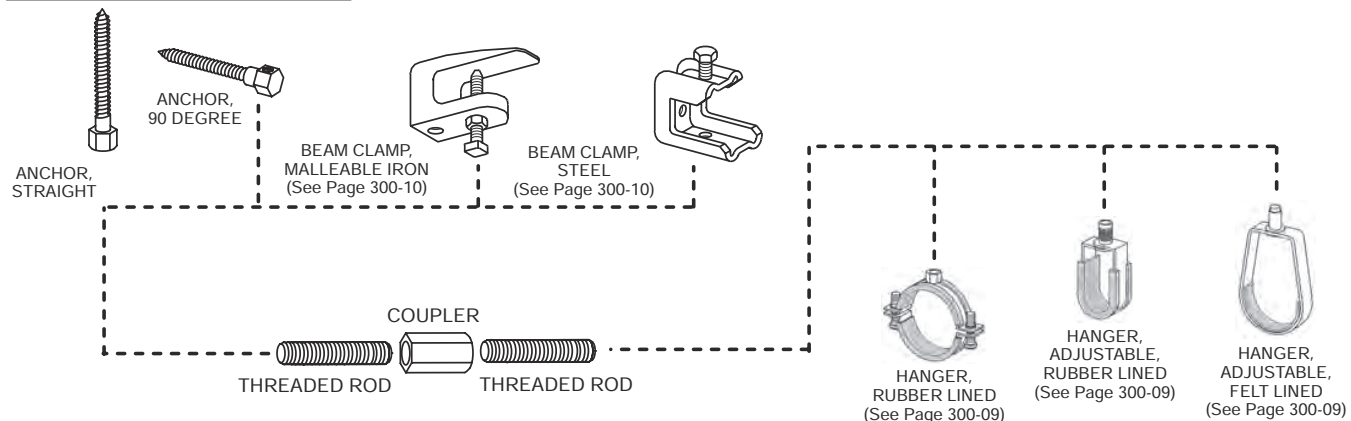

## HANGER, BELL

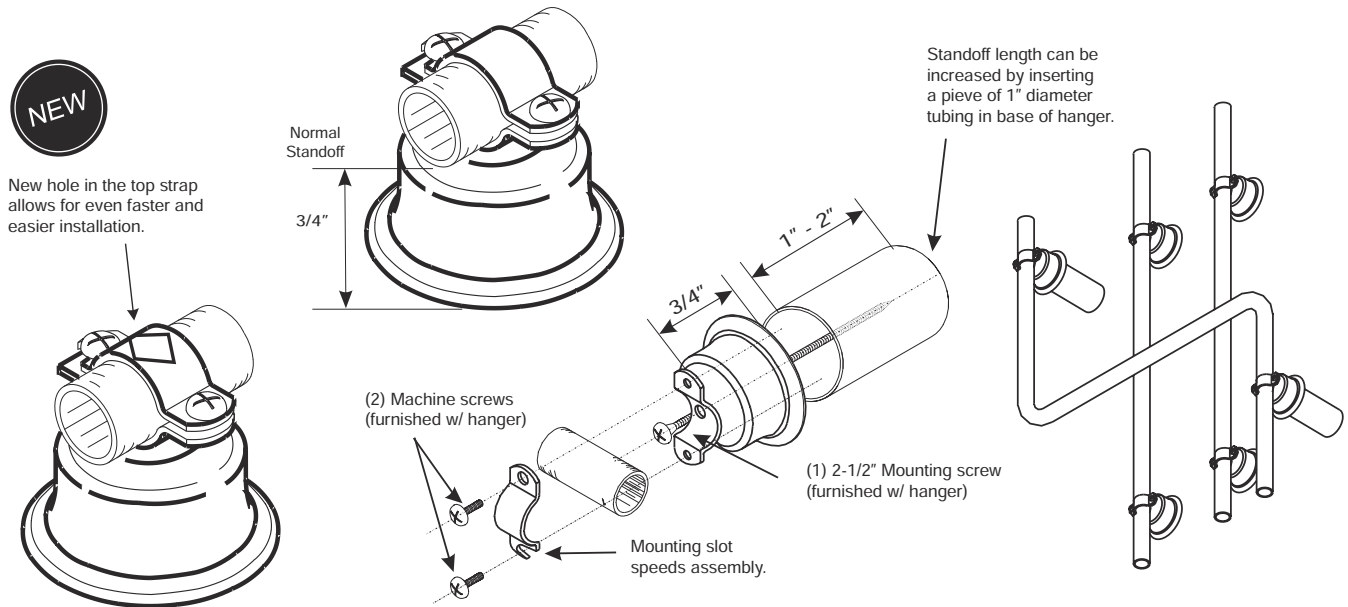

- Also available with plastic coated finish.
- Hangers for 1/2", 3/4" & 1" tube sizes.
- All Bell Hangers come furnished with one 2-1/2" mounting screw.

PART NO. COPPER	PART NO. PLASTIC	PART NO. COPPER W/ HOLE	PIPE SIZE	DIA.	CARTON QUANTITY	WT./CTN. (Lbs.)	COPPER LIST PRICE	PLASTIC LIST PRICE	COPPER LIST PRICE W/ HOLE
BBH-500	BBH-500-P	BBH-500-D	1/2"	0.632"	25	2	\$0.8501	\$1.1722	\$0.8501
BBH-750	BBH-750-P	BBH-750-D	3/4"	0.882"	25	2	\$0.8585	\$1.1806	\$0.8585
BBH-1000	BBH-1000-P	BBH-1000-D	1"	1.130"	25	2	\$0.8845	\$1.2064	\$0.8845

## HANGER, UNIVERSAL PIPE

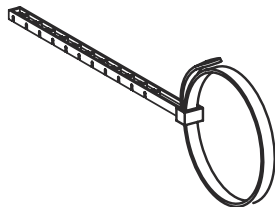

- Fits Pipe 7/8" O.D. to 6-7/8" O.D.
- ABS shank, nylon 66 strap.
- Snap off sections.
- Includes two, pre-loaded nails.
- Releasable locking mechanism.
- Can also be used to support flexible ducting.

PART NUMBER	DESCRIPTION	CARTON QUANTITY	WT./CTN. (Lbs.)	LIST PRICE
UPH-10W-5	10" Universal Pipe Hanger, White	25	5	\$1.9868
UPH-14W-5	14" Universal Pipe Hanger, White	25	5	\$2.4093
UPH-26W-5	26" Universal Pipe Hanger, White	25	8	\$3.7488

## HANGER, DWV (DRAIN WASTE VENT)

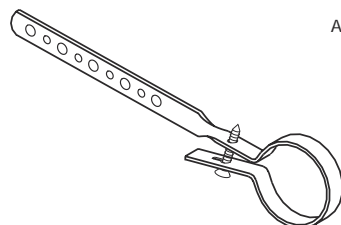

**MATERIAL:** 18 ga. Galvanized steel.  
Also available with plastic coated loop.

**DIMENSIONS:** 3/4" wide x 12" long excluding loop.

**APPLICATION:** Designed for rapid installation of both ABS and PVC plastic DWV piping systems. Slotted holes accept screws or nails.

**LOAD RATING:** 150 lbs. maximum.

PART NO. GALVANIZED	PART NO. PLASTIC COATED	PIPE SIZE	CARTON QUANTITY	WT./CTN. (Lbs.)	GALVANIZED LIST PRICE	PLASTIC COATED LIST PRICE
DWV-112-5	DWV-112-P-5	1-1/2"	25	5	\$0.8765	\$1.0940
DWV-2-5	DWV-2-P-5	2"	25	7	\$0.9889	\$1.2064
DWV-3-5	DWV-3-P-5	3"	25	8	\$1.1125	\$1.3300
DWV-4-5	DWV-4-P-5	4"	25	10	\$1.3036	\$1.5211

# HANGERS

## HANGER, RIGID

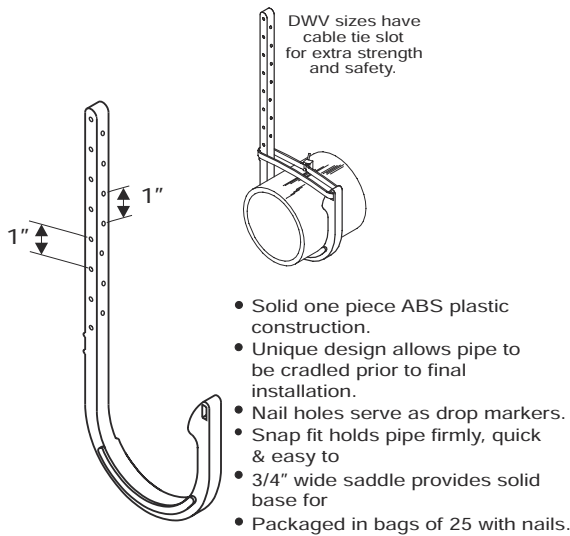

Suitable for plumbing supply lines. Hydronic Heat Piping, DWV lines & Furnace vent lines.

PART NUMBER	PIPE SIZE	MAX. LOAD (Lbs.)	QUANTITY/ BAG	BAG WEIGHT (Lbs.)	LIST PRICE
<b>Copper Tube Size(CTS)</b>					
BRH-12	1/2"	70	25	1	\$0.5294
BRH-34	3/4"	70	25	1	\$0.5647
BRH-1	1"	60	25	1	\$0.5817
<b>Drain Waste Vent Sizes (DWV)</b>					
BRH-112	1-1/2"	45	25	2	\$0.6706
BRH-2	2"	40	25	2	\$0.6959
BRH-3	3"	35	25	3	\$0.7567
BRH-4	4"	35	25	3	\$0.8179

## HANGER, SWIVEL

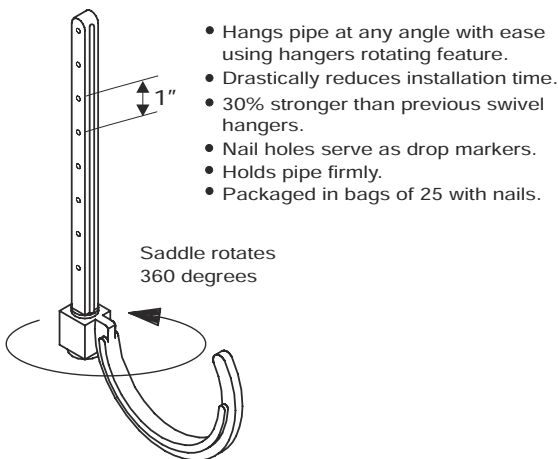

Swivel saddle holds PVC, Copper, Polybutylene and CPVC pipe securely, yet allows for expansion and contraction

Made of white ABS plastic.

PART NUMBER	PIPE SIZE	MAX. LOAD (Lbs.)	QUANTITY/ BAG	BAG WEIGHT (Lbs.)	LIST PRICE
<b>Copper Tube Size(CTS)</b>					
SH-12	1/2"	55	25	2	\$0.6706
SH-34	3/4"	40	25	2	\$0.6987
SH-1	1"	40	25	2	\$0.7268
SH-114	1-1/4"	30	25	2	\$0.7557
<b>Drain Waste Vent Sizes (DWV)</b>					
SH-112	1-1/2"	30	25	3	\$0.7762
SH-2	2"	25	25	3	\$0.7802
SH-3	3"	20	25	3	\$0.8269
SH-4	4"	20	25	4	\$0.8888

## TECHNICAL DATA

PIPE CAPACITIES AND WEIGHTS					
SIZE	WEIGHT PER FOOT(Lbs.)		SECTION LENGTH	WEIGHT PIPE SECTIONS (Lbs.)	
	EMPTY	FULL OF WATER		EMPTY	FULL OF WATER
<b>Copper Tube Size (CTS)</b>					
1/2"	.28	.365	SIX FOOT SECTION	1.7	2.2
3/4"	.45	.64		2.7	3.9
1"	.66	1.00		4.0	6.0
1-1/4"	.88	1.41		5.3	8.5
<b>Drain Waste Vent Sizes (DWV)</b>					
1-1/2"	.36	1.4	FOUR FOOT SECTION	1.44	5.6
2"	.48	2.1		1.92	8.4
3"	1.00	4.6		4.0	18.4
4"	1.42	7.5		5.68	30.0

PIPE HANGER SPACING	
NOMINAL TUBING SIZE	MAXIMUM SPAN
1/2"	5'
3/4"	5'
1"	6'
1-1/4"	7'
1-1/2"	8'
2"	8'
2-1/2"	9'
3"	10'
3-1/2"	11'
4"	12'



## WIRE PIPE

Be sure to specify 9 or 11 gauge when ordering Pipe Hooks.

When gauge is not specified, 9 gauge will be shipped.

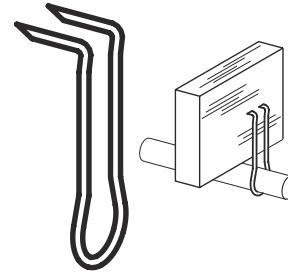

## 4" X 9 GA. WIRE PIPE HOOKS

### PLAIN STEEL - PWS 4" X 9 GA.

QUANTITY: 50 TO THE CARTON	1/2"x4"	3/4"x4"	1"x4"	1-1/4"x4"	1-1/2"x4"
PART NUMBER	12X4-9PWS	34X4-9PWS	1X4-9PWS	114X4-9PWS	112X4-9PWS
WT. PER CARTON	3 Lbs.	3 Lbs.	3 Lbs.	3 Lbs.	3 Lbs.
LIST PRICE:	\$0.1494	\$0.1534	\$0.1559	\$0.1598	\$0.1640

### COPPER PLATED - PWC 4" X 9 GA.

QUANTITY: 50 TO THE CARTON	1/2"x4"	3/4"x4"	1"x4"	1-1/4"x4"	1-1/2"x4"
PART NUMBER	12X4-9PWC	34X4-9PWC	1X4-9PWC	114X4-9PWC	112X4-9PWC
WT. PER CARTON	3 Lbs.	3 Lbs.	3 Lbs.	3 Lbs.	3 Lbs.
LIST PRICE:	\$0.1692	\$0.1718	\$0.1768	\$0.1929	\$0.2018

### PLASTIC COATED - PWP 4" X 9 GA.

QUANTITY: 50 TO THE CARTON	1/2"x4"	3/4"x4"	1"x4"	1-1/4"x4"	1-1/2"x4"
PART NUMBER	12X4-9PWP	34X4-9PWP	1X4-9PWP	114X4-9PWP	112X4-9PWP
WT. PER CARTON	4 Lbs.	4 Lbs.	4 Lbs.	4 Lbs.	4 Lbs.
LIST PRICE:	\$0.3640	\$0.3682	\$0.3705	\$0.3744	\$0.3786

## 6" x 9 GA. WIRE PIPE HOOKS

### PLAIN STEEL - PWS 6" X 9 GA.

QUANTITY: 50 TO THE CARTON	1/2"x6"	3/4"x6"	1"x6"	1-1/4"x6"	1-1/2"x6"
PART NUMBER	12X6-9PWS	34X6-9PWS	1X6-9PWS	114X6-9PWS	112X6-9PWS
WT. PER CARTON	4 Lbs.	4 Lbs.	4 Lbs.	4 Lbs.	4 Lbs.
LIST PRICE:	\$0.1743	\$0.1782	\$0.1859	\$0.1901	\$0.1972

### COPPER PLATED - PWC 6" X 9 GA.

QUANTITY: 50 TO THE CARTON	1/2"x6"	3/4"x6"	1"x6"	1-1/4"x6"	1-1/2"x6"
PART NUMBER	12X6-9PWC	34X6-9PWC	1X6-9PWC	114X6-9PWC	112X6-9PWC
WT. PER CARTON	4 Lbs.	4 Lbs.	4 Lbs.	4 Lbs.	4 Lbs.
LIST PRICE:	\$0.2000	\$0.2076	\$0.2182	\$0.2220	\$0.2310

### PLASTIC COATED- PWP 6" X 9 GA.

QUANTITY: 50 TO THE CARTON	1/2"x6"	3/4"x6"	1"x6"	1-1/4"x6"	1-1/2"x6"
PART NUMBER	12X6-9PWP	34X6-9PWP	1X6-9PWP	114X6-9PWP	112X6-9PWP
WT. PER CARTON	5 Lbs.	5 Lbs.	5 Lbs.	5 Lbs.	5 Lbs.
LIST PRICE:	\$0.3890	\$0.3928	\$0.4005	\$0.4048	\$0.4117

# HOOKS

## WIRE PIPE

Be sure to specify 9 or 11 gauge when ordering Pipe Hooks.

When gauge is not specified, 9 gauge will be shipped.

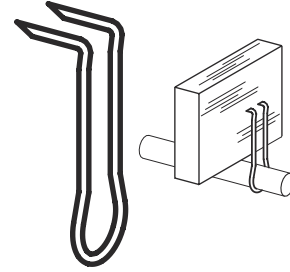

### 8" X 9 GA. WIRE PIPE HOOKS

#### PLAIN STEEL - PWS 8" X 9 GA.

QUANTITY: 50 TO THE CARTON	1/2"x8"	3/4"x8"	1"x8"	1-1/4"x8"	1-1/2"x8"
PART NUMBER	12X8-9PWS	34X8-9PWS	1X8-9PWS	114X8-9PWS	112X8-9PWS
WT. PER CARTON	5 Lbs.	5 Lbs.	5 Lbs.	6 Lbs.	6 Lbs.
LIST PRICE:	\$0.2027	\$0.2143	\$0.2203	\$0.2266	\$0.2323

#### COPPER PLATED - PWC 8" X 9 GA.

QUANTITY: 50 TO THE CARTON	1/2"x8"	3/4"x8"	1"x8"	1-1/4"x8"	1-1/2"x8"
PART NUMBER	12X8-9PWC	34X8-9PWC	1X8-9PWC	114X8-9PWC	112X8-9PWC
WT. PER CARTON	5 Lbs.	5 Lbs.	5 Lbs.	6 Lbs.	6 Lbs.
LIST PRICE:	\$0.2374	\$0.2526	\$0.2609	\$0.2658	\$0.2739

#### PLASTIC COATED - PWP 8" X 9 GA.

QUANTITY: 50 TO THE CARTON	1/2"x8"	3/4"x8"	1"x8"	1-1/4"x8"	1-1/2"x8"
PART NUMBER	12X8-9PWP	34X8-9PWP	1X8-9PWP	114X8-9PWP	112X8-9PWP
WT. PER CARTON	6 Lbs.	6 Lbs.	6 Lbs.	7 Lbs.	7 Lbs.
LIST PRICE:	\$0.4173	\$0.4291	\$0.4350	\$0.4414	\$0.4469

### 4" x 11 GA. WIRE PIPE HOOKS

#### PLAIN STEEL - PWS 4" X 11 GA.

QUANTITY: 50 TO THE CARTON	1/2"x4"	3/4"x4"	1"x4"	1-1/4"x4"	1-1/2"x4"
PART NUMBER	12X4-11PWS	34X4-11PWS	1X4-11PWS	114X4-11WS	112X4-11PWS
WT. PER CARTON	2 Lbs.	2 Lbs.	2 Lbs.	2 Lbs.	2 Lbs.
LIST PRICE:	\$0.1338	\$0.1366	\$0.1386	\$0.1412	\$0.1430

#### COPPER PLATED - PWC 4" X 11 GA.

QUANTITY: 50 TO THE CARTON	1/2"x4"	3/4"x4"	1"x4"	1-1/4"x4"	1-1/2"x4"
PART NUMBER	12X4-11PWC	34X4-11PWC	1X4-11PWC	114X4-11PWC	112X4-11PWC
WT. PER CARTON	2 Lbs.	2 Lbs.	2 Lbs.	2 Lbs.	2 Lbs.
LIST PRICE:	\$0.1482	\$0.1517	\$0.1550	\$0.1594	\$0.1607

#### COPPER PLATED - PWC 4" X 11 GA.

QUANTITY: 50 TO THE CARTON	1/2"x4"	3/4"x4"	1"x4"	1-1/4"x4"	1-1/2"x4"
PART NUMBER	12X4-11PWP	34X4-11PWP	1X4-11PWP	114X4-11PWP	112X4-11PWP
WT. PER CARTON	3 Lbs.	3 Lbs.	3 Lbs.	3 Lbs.	3 Lbs.
LIST PRICE:	\$0.3486	\$0.3510	\$0.3534	\$0.3558	\$0.3577

## WIRE PIPE

Be sure to specify 9 or 11 gauge when ordering Pipe Hooks.

When gauge is not specified, 9 gauge will be shipped.

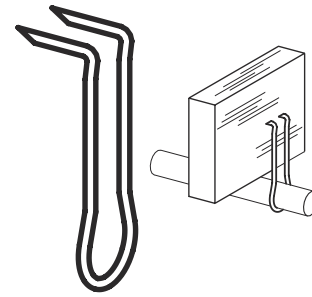

### 6" X 11 GA. WIRE PIPE HOOKS

#### PLAIN STEEL - PWS 6" X 11 GA.

QUANTITY: 50 TO THE CARTON	1/2"x6"	3/4"x6"	1"x6"	1-1/4"x6"	1-1/2"x6"
PART NUMBER	12X6-11PWS	34X6-11PWS	1X6-11PWS	114X6-11PWS	112X6-11PWS
WT. PER CARTON	3 Lbs.	3 Lbs.	3 Lbs.	3Lbs.	3 Lbs.
LIST PRICE:	\$0.1366	\$0.1386	\$0.1418	\$0.1438	\$0.1457

#### COPPER PLATED - PWC 6" X 11 GA.

QUANTITY: 50 TO THE CARTON	1/2"x6"	3/4"x6"	1"x6"	1-1/4"x6"	1-1/2"x6"
PART NUMBER	12X6-11PWC	34X6-11PWC	1X6-11PWC	114X6-11PWC	112X6-11PWC
WT. PER CARTON	3 Lbs.	3 Lbs.	3 Lbs.	3 Lbs.	3 Lbs.
LIST PRICE:	\$0.1607	\$0.1646	\$0.1668	\$0.1692	\$0.1720

#### PLASTIC COATED - PWP 6" X 11 GA.

QUANTITY: 50 TO THE CARTON	1/2"x6"	3/4"x6"	1"x6"	1-1/4"x6"	1-1/2"x6"
PART NUMBER	12X6-11PWP	34X6-11PWP	1X6-11PWP	114X6-11PWP	112X6-11PWP
WT. PER CARTON	4 Lbs.	4 Lbs.	4 Lbs.	4 Lbs.	4 Lbs.
LIST PRICE:	\$0.3510	\$0.3534	\$0.3566	\$0.3586	\$0.3605

### 2 1/2" X 11 GA. WIRE PIPE HOOKS

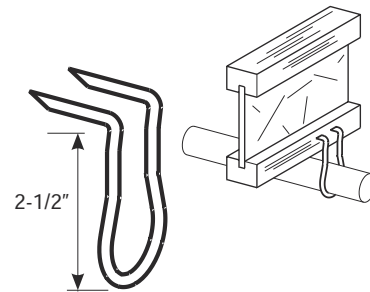

#### PLAIN STEEL - PWS 2 1/2" X 11 GA.

QUANTITY: 100 TO THE CARTON	1/2"x2-1/2"	3/4"x2-1/2"	1"x2-1/2"
PART NUMBER	12X212-11PWS	34X212-11PWS	1X212-11PWS
WT. PER CARTON	2 Lbs.	2 Lbs.	2 Lbs.
LIST PRICE:	\$0.0674	\$0.0687	\$0.0795

#### COPPER PLATED - PWC 2 1/2" X 11 GA.

QUANTITY: 100 TO THE CARTON	1/2"x2-1/2"	3/4"x2-1/2"	1"x2-1/2"
PART NUMBER	12X212-11PWC	34X212-11PWC	1X212-11PWC
WT. PER CARTON	2 Lbs.	2 Lbs.	2 Lbs.
LIST PRICE:	\$0.0735	\$0.0748	\$0.0857

# SUPPORTS, STANDS

## STAND, WATER HEATER, STANDARD

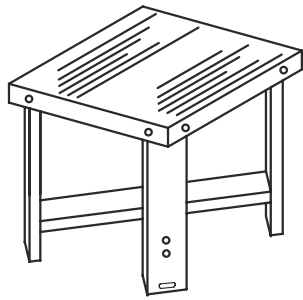

Durable 18 GA.  
Galvanized Steel Stands

- WHS-1 recommended for 30-50 gallon capacity gas water heaters. 650 lb. safe working load.
- WHS-2 1300 Lb. safe working load.
- Legs are cross braced to prevent tipping.
- Both WHS-1 and WHS-2 models safely support water heater 18" above the floor as required by the National Fuel Gas Code and Uniform Plumbing Code.
- Stands shipped unassembled for ease in handling.

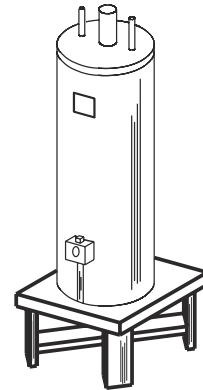

See page 300-18 for Seismic Restraint Clip ordering information

PART NUMBER	WIDTH	DEPTH	HT.	GA.	MAX. LOAD (Lbs.)	UNITS/CTN.	WT./CTN. (Lbs.)	LIST PRICE
WHS-1	21"	21"	18"	18	650	1	15	\$30.07
WHS-2	24"	24"	18"	16	1300	1	22	\$79.43

## STAND, WATER HEATER, FAST ASSEMBLY

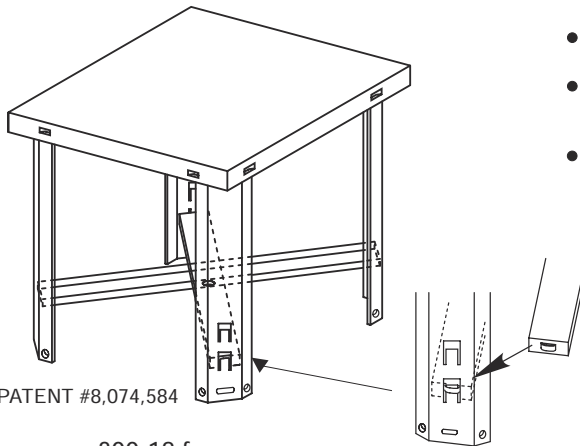

PATENT #8,074,584

- **LESS ASSEMBLY TIME REQUIRED.**  
Stand assembles in 80% less time than our standard model.
- **FEWER PARTS.**  
Innovative locking tab design for legs, tabletop and cross bracing attachment.
- **COMPACT SHIPPING.**  
Water heater stand is shipped unassembled in box protecting the stand from factory to job site. No need to haul a cumbersome assembled stand around.
  - Legs are cross braced to prevent tipping.
  - Two (2) seismic restraint hardware mounting holes bottom of each leg. (Hardware furnished by others.)
  - Holds up to 50 gallon water heater 18" above the floor as required by the National Fuel Gas Code and Uniform Plumbing Code.

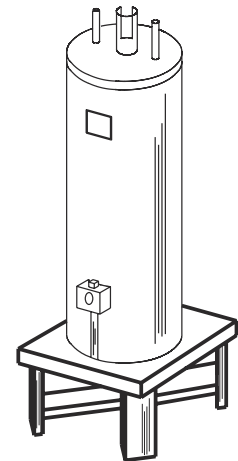

See page 300-18 for Seismic Restraint Clip ordering information

PART NUMBER	WIDTH	DEPTH	HT.	GA.	MAX. LOAD (LBS.)	UNITS/CTN.	WT./CTN. (Lbs.)	LIST PRICE
WHS-1FA	21"	21"	18"	18	650	1	15	\$30.07

Durable 18 GA.  
Galvanized Steel Stands

## STAND, WATER HEATER, OVERHEAD SUPPORT

Adequately support water heater from the overhead in accordance with good engineering practice.

- Wide platform allows water heaters up to 21-1/4" diameter.
- Static load rating of 375 pounds, depending on structural attachment.
- Galvanized steel construction.
- Strong four corner braces accept 3/8" or 1/2" threaded rod.

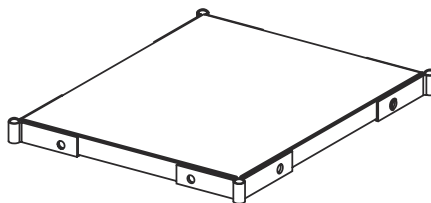

Material:  
Pan: 18 gauge, CRS, galvanized.  
Corners: 16 gauge, CRS, galvanized.

Contractor furnished 3/8" or 1/2" threaded support rods. (Typical four corners). (For ordering information see Page 300-11)

20-gallon water heater (maximum 375 lb. load)

Water heater pan. (See page 300-19 for ordering)

Contractor furnished 3/8" or 1/2" locknuts and washers. (Typical four corners)

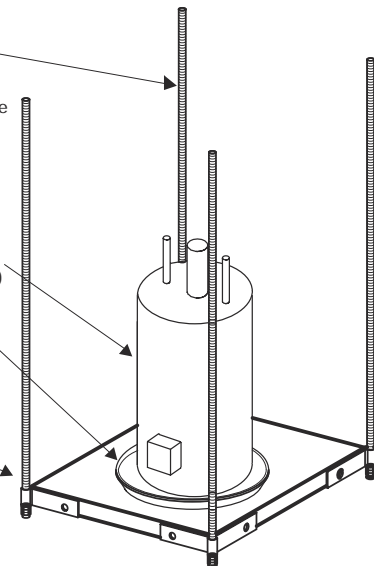

PART NUMBER	WIDTH	DEPTH	GA.	MAX. LOAD (LBS.)	UNITS/CTN.	WT./CTN. (Lbs.)	LIST PRICE
WHS-1SP	21-1/4"	21-1/4"	18	375	1	8	\$37.51

## CLIP, SEISMIC RESTRAINT, WATER HEATER STAND

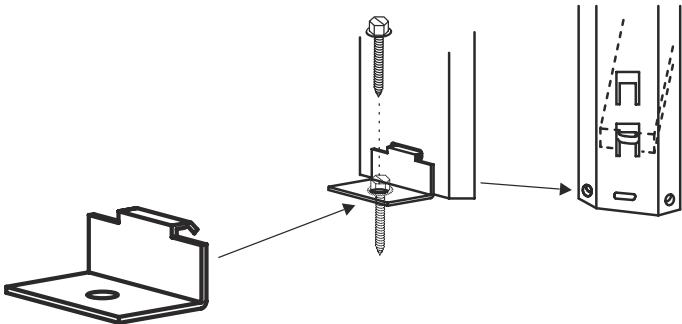

- Seismic restraint clip anchors water heater stand leg to floor.
- Can be used on Models WHS-1, WHS-1EN, WHS-1FA and WHS-1FAEN.

PART NUMBER	MATERIAL	GA.	UNITS/CTN.	WT./CTN. (Lbs.)	LIST PRICE
SRC	GALV. STEEL	16	24	1	\$0.5585

## STAND, WATER HEATER, ENCLOSED

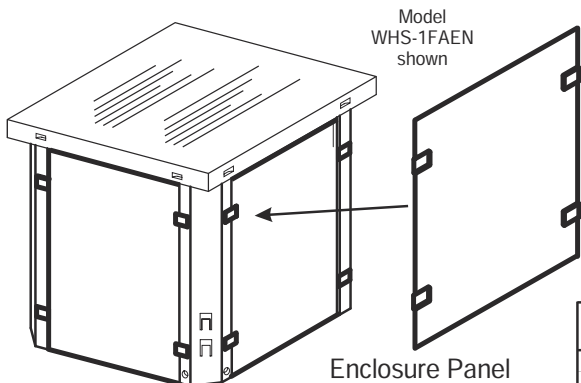

- Same stand as Models WHS-1 and WHS-1FA, but includes four (4) 26 ga. side panels. 650 lb. safe working load.
- Water heater stand is fully enclosed on four sides to prevent storage of flammable liquids.
- Ideal for use in food processing areas.
- Stands shipped unassembled for ease in handling.
- Side panels easily slide into position once stand is assembled.
- Model WHS-1EN utilizes standard nut/bolt assembly. Model WHS-1FAEN utilizes fast assemble slip joints.

PART NUMBER	WIDTH	DEPTH	HT.	GA. (STAND)	GA. (SIDES)	MAX. LOAD (Lbs.)	UNITS/CTN.	WT./CTN. (Lbs.)	LIST PRICE
WHS-1EN	21"	21"	18"	18	26	650	1	22	\$38.68
WHS-1FAEN	21"	21"	18"	18	26	650	1	22	\$38.68

## STAND, WATER HEATER, QUAKE RESISTANT

QSK-1

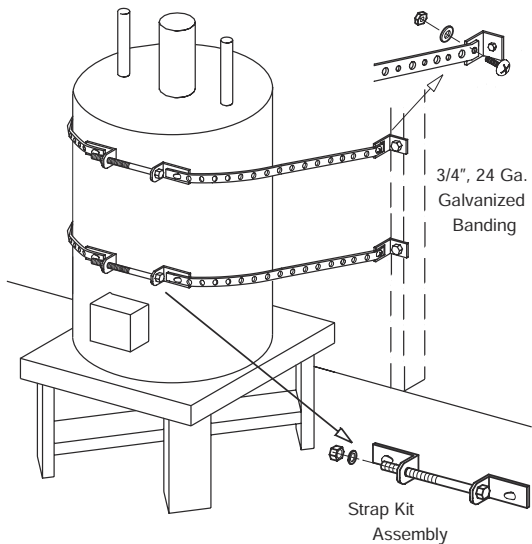

QSK-150

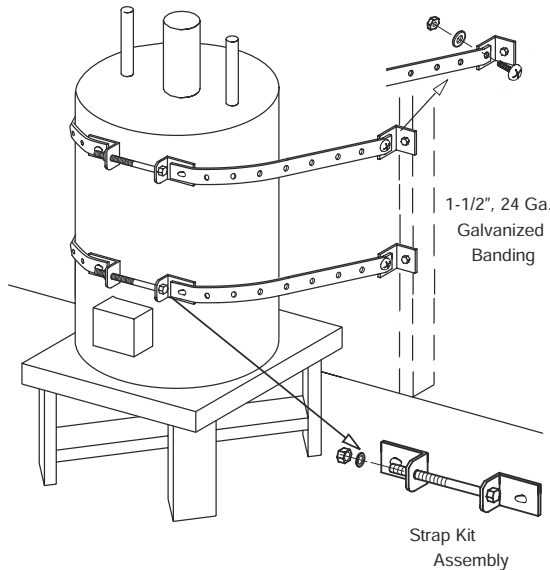

A complete kit for securing water heaters to an adjacent wall. Kit assembles quickly and easily and contains all necessary bolts, screws, washers, nuts, brackets and heavy duty 3/4" or 1-1/2" wide, 24 GA. galvanized strapping to complete the installation.

Contents of kit are shown in each illustration.

PART NUMBER	STRAP WIDTH	STRAP GA.	UNITS/CTN.	WT./CTN. (Lbs.)	LIST PRICE
QSK-1	3/4"	24	1	3	\$12.28
QSK-150	1-1/2"	24	1	5	\$17.86



# MISCELLANEOUS

## PAN, WATER HEATER, ALUMINUM

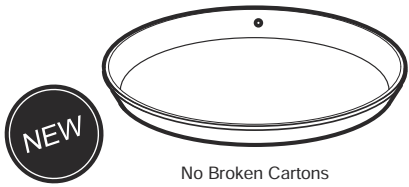

No Broken Cartons

- Protect floors and ceilings from water damage.
- Round shaped aluminum pan.
- Pre-drilled for 1" CPVC or PVC drain (included).
- Complies with SBCCI Code Section 1213.7.

CPVC PART NUMBER	PVC PART NUMBER	BOTTOM I.D.	TOP MAX. I.D.	CARTON QUANTITY	WT./CTN. (Lbs.)	CPVC PART LIST PRICE	PVC PART LIST PRICE
AWHPC-20-5	AWHP-20-5	20"	22"	10	16	\$17.41	\$17.42
AWHPC-22-5	AWHP-22-5	22"	24"	10	20	\$19.88	\$19.89
AWHPC-24-5	AWHP-24-5	24"	26"	10	23	\$22.04	\$22.05
AWHPC-26-5	AWHP-26-5	26"	28"	10	26	\$24.40	\$24.41
AWHPC-30-5	AWHP-30-5	30"	32"	5	15	\$31.54	\$33.48

## PAN, WATER HEATER, PLASTIC

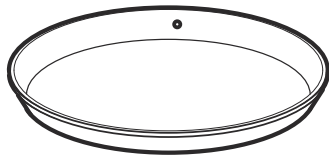

No Broken Cartons

- Protect floors and ceilings from water damage.
- Round shaped black plastic pan.
- Pre-drilled for 1" drain (included).
- Complies with SBCCI Code Section 1213.7.

PART NUMBER	BOTTOM I.D.	TOP MAX. I.D.	DRAIN MATL.	CARTON QUANTITY	WT./CTN. (Lbs.)	LIST PRICE
WHP-24-5	24"	26"	PVC	20	28	\$7.21
WHP-26-5	26"	28"	PVC	10	17	\$9.46
WHP-30-5	30"	32"	PVC	5	11	\$11.60
WHPC-20-5	20"	22"	CPVC	10	16	\$9.28
WHPC-22-5	22"	24"	CPVC	10	20	\$9.62
WHPC-24-5	24"	26"	CPVC	10	23	\$10.11
WHPC-26-5	26"	28"	CPVC	10	25	\$12.47
WHPC-30-5	30"	32"	CPVC	5	17	\$16.81

## PAN, WASHING MACHINE, PLASTIC

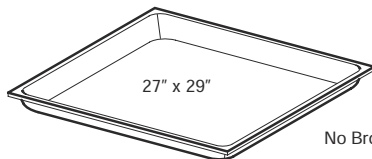

27" x 29"

No Broken Cartons

- Protect floors and ceilings from water damage.
- Rectangular shaped white plastic pan.
- 1" drain fitting (included).
- Pan NOT drilled.

PART NUMBER	BOTTOM DIM.	TOP MAX. DIM.	CARTON QUANTITY	WT./CTN. (Lbs.)	LIST PRICE
WMP-1-5	27"x29"	281/2"x301/2"	5	15	\$19.67

## CLAMP, DUCT, BOLT-ON & COMPRESSION, LOC-ON

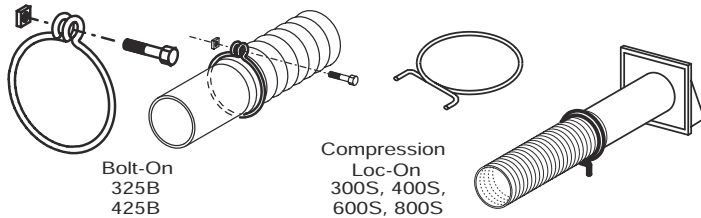

Bolt-On  
325B  
425B

Compression  
Loc-On  
300S, 400S,  
600S, 800S

- Bolt-On model accommodates semi rigid aluminum duct.
- Compression, Loc-On is ideal for clothes dryer vent attachment and other flexible duct installations.

PART NUMBER	DIAMETER	CARTON QUANTITY	WT./CTN. (Lbs.)	LIST PRICE
300S	3"	1000	56	\$0.6003
400S	4"	500	32	\$0.6367
600S	6"	50	7	\$1.4555
800S	8"	50	7.5	\$2.0011
325B	3"	1000	51	\$1.0188
425B	4"	1000	60	\$1.0914

## CLAMP, HOSE, WORM GEAR



5" Standard Stainless  
Steel Clamp

- 5" max. diameter, 1/4" min. diameter.
- Multi-use clamp with wide diameter range.

PART NUMBER	MATERIAL	SIZE	CARTON QUANTITY	WT./CTN. (Lbs.)	LIST PRICE
SSC-5	Stainless Steel	5"	25	2	\$1.5912

## RING, EXTENSION, WATER CLOSET, TAPERED & FLUSH MOUNT

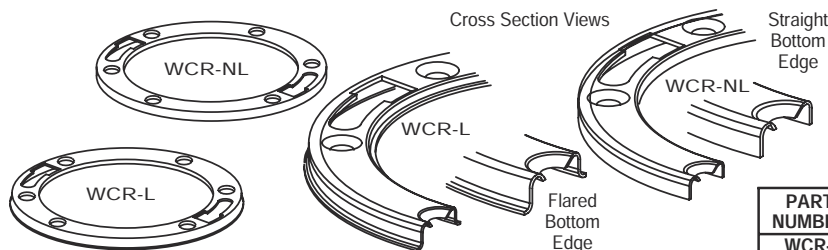

Cross Section Views

Straight Bottom Edge

Flared Bottom Edge

- WCR-L flared bottom edge suitable for reconstructing damaged existing installations.
- Corrosion resistant.
- Fits securely over damaged flange.
- Available with tapered (flared) (WCR-L) or flush (WCR-NL) edge.

PART NUMBER	MATERIAL	CARTON QUANTITY	WT./CTN. (Lbs.)	LIST PRICE
WCR-L	Stainless Steel	20	8	\$4.17
WCR-NL	Stainless Steel	20	7	\$4.09

# BRACKETS, CLIPS, STRAPS

## BRACKET, ADJUSTABLE, SELF-NAILING, PEX

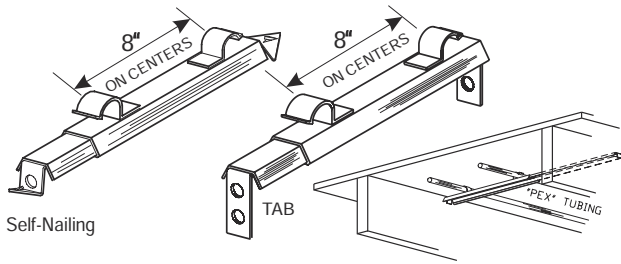

"PEX" TUBING SNAPS EASILY INTO "PEX" CLIPS

- Extra long model has "PEX" clips 12" on centers.
- Clips for 3/8" available by special order.

PART NO.	TYPE	LENGTH ADJUST	MATERIAL	CARTON QUANTITY	WT./CTN. (Lbs.)	LIST PRICE
A-125-P	Self Nailing, Regular	12" to 19"	Galv.	25	5	\$1.1577
AT-125-P	Tab, Regular	12" to 19"	Galv.	25	5	\$1.1935
E-125-P	Self Nailing, Extra Long	19" to 26"	Galv.	25	8	\$1.3353
ET-125-P	Tab, Extra Long	19" to 26"	Galv.	25	8	\$1.3653

## KIT, TUBING, SNAP N' SLIDE



Snap clamps on to bracket, then slide to proper position.

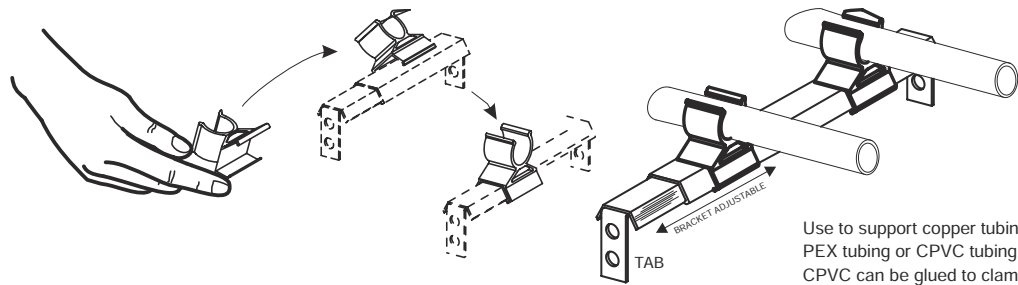

Use to support copper tubing, PEX tubing or CPVC tubing. CPVC can be glued to clamp.

The Basset "Snap N' Slide" tubing clamp, when used with a Basset Telescoping Bracket, is ideal for supporting PEX, CPVC or copper tubing for radiant heat as well as for stubbing out copper tubing or CPVC supply lines.

PART NUMBER	DESCRIPTION	CARTON QUANTITY	WT./CTN. (Lbs.)	LIST PRICE
SSA1-12	1-Self nailing bracket w/2 1/2" clamps	25	6	\$1.4707
SSA1-34	1-Self nailing bracket w/2 3/4" clamps	25	6	\$1.4707
SSAT-12	1-Tab bracket w/2 1/2" clamps	25	6	\$1.5064
SSAT-34	1-Tab bracket w/2 3/4" clamps	25	6	\$1.5064
SSC-12	1/2" Snap N' Slide clamp only	50	1	\$0.3711
SSC-34	3/4" Snap N' Slide clamp only	50	1	\$0.3711

## CLIP, MESH, "PEX"

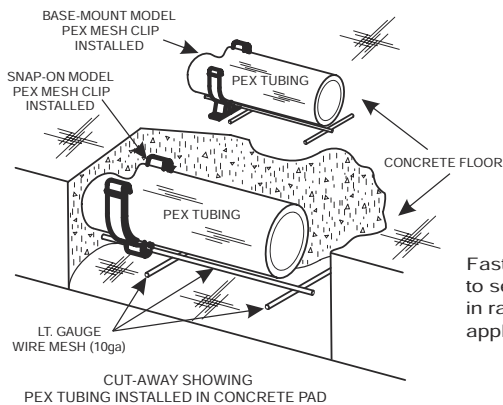

Fast, economical way to secure PEX tubing in radiant concrete slab applications.

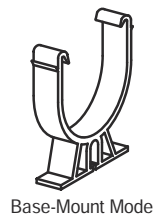

Base-Mount Model

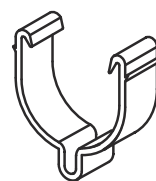

Snap-On Model

PART NUMBER	DESCRIPTION	CARTON QUANTITY	WT./CTN. (Lbs.)	LIST PRICE
PMC-SO12-5	Snap-On 1/2"	250	3	\$0.1236
PMC-SO34-5	Snap-On 3/4"	250	4	\$0.1461
PMC-BM12-5	Base Mount 1/2"	250	6	\$0.1686

## STRAP, MESH, "PEX"

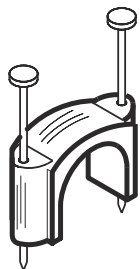

- Available in both "RED" for "Hot Water" and "BLUE" for "Cold Water" PEX supply lines.
- Makes a PEX potable water installation look even more professional.

PART NUMBER	SIZE CTS	COLOR	CARTON QUANTITY	WT./CTN. (Lbs.)	LIST PRICE
PTS-500R-5	1/2"	Red	100	2	\$0.0809
PTS-750R-5	3/4"	Red	50	2	\$0.1349
PTS-1000R-5	1"	Red	25	1	\$0.1865
PTS-500B-5	1/2"	Blue	100	2	\$0.0809
PTS-750B-5	3/4"	Blue	50	2	\$0.1349
PTS-1000B-5	1"	Blue	25	1	\$0.1865
PTS-500W-5	1/2"	White	100	2	\$0.0809
PTS-750W-5	3/4"	White	50	2	\$0.1349
PTS-1000W-5	1"	White	25	1	\$0.1865

# BRACKETS, SUPPORTS

## KIT, BRACKET, MOUNTING, HYCO, PEX

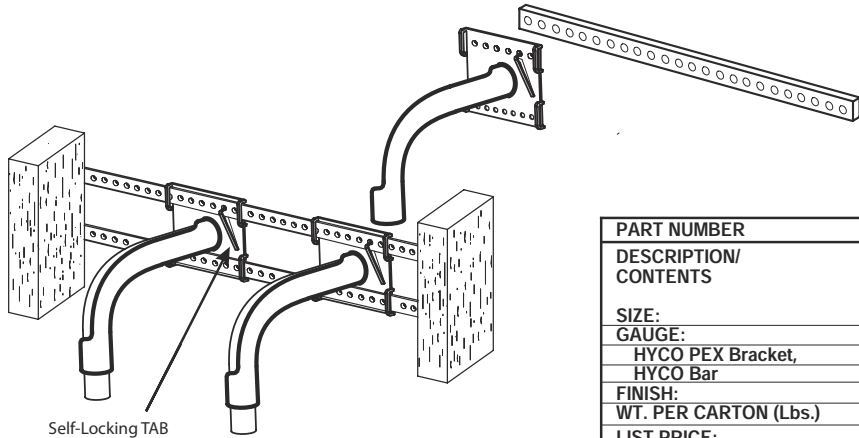

- Eliminate in-wall fittings & joints.
- Fast and economical method of stubbing-out PEX tubing.
- Self locking tab must be compressed tightly to bracket with pliers.

PART NUMBER	HPA-500	HPA-750
DESCRIPTION/ CONTENTS	(25) 1/2" Hyco PEX Brackets & (50) 18" Hyco bars	(25) 3/4" Hyco PEX Brackets & (50) 18" Hyco bars
SIZE:		
GUAGE:		
HYCO PEX Bracket,	18 ga.	18 ga.
HYCO Bar	14 ga.	14 ga.
FINISH:	Galvanized	Galvanized
WT. PER CARTON (Lbs.)	17	20
LIST PRICE:	\$64.14	\$90.52

## HYCO PEX BRACKET

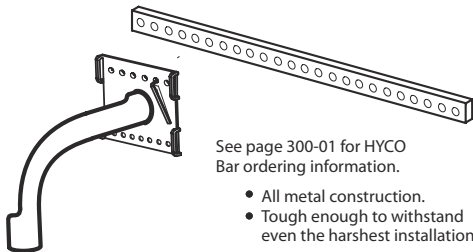

See page 300-01 for HYCO Bar ordering information.

- All metal construction.
- Tough enough to withstand even the harshest installations.

- Fast and economical method of stubbing-out PEX tubing.
- Self locking tab must be compressed tightly to bracket with pliers.

PART NUMBER	HP-500	HP-750
SIZE:	1/2"	3/4"
GUAGE:	18 ga.	18 ga.
FINISH:	Galvanized	Galvanized
CARTON QUANTITY:	25	25
WT. PER CARTON (Lbs.)	5	8
LIST PRICE:	\$1.7645	\$2.8198

## PEX SIDEWINDER W/ MOUNTING PLATE

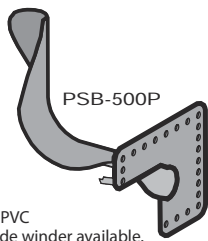

PSB-500P

- Optional PVC coated Side winder available.
- Durability of metal base material combined with PVC coating eliminates PEX tube contact with metal bend support.

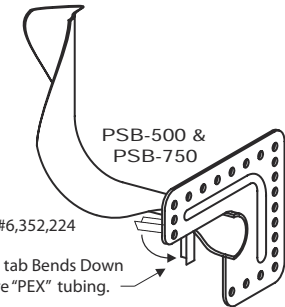

Patent #6,352,224

Locking tab Bends Down to secure "PEX" tubing.

- Unique open corner on mounting plate allows bracket to be added anytime along "PEX" tubing.
- Connection free stub out for PEX tubing.

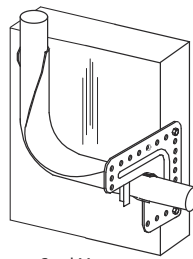

Stud Mount

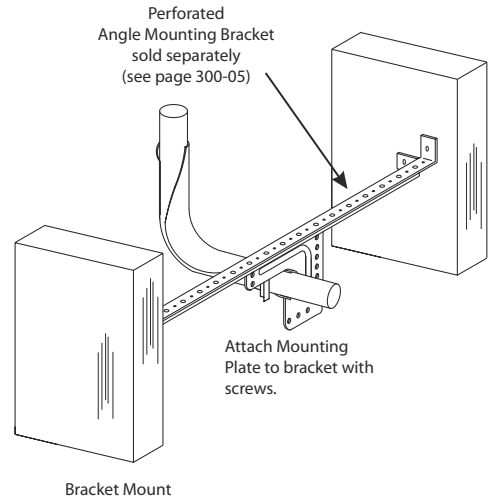

Bracket Mount

PART NUMBER	PSB-500	PSB-750	PSB-500P
NAIL PLATE GAUGE:	20	18	20
BEND GAUGE:	18	17	18
FINISH:	Galv. Steel	Galv. Steel	PVC
SIZE:	3/8" & 1/2"	3/4"	3/8" & 1/2"
CARTON QUANTITY:	25	25	25
WT. PER CARTON (Lbs.)	5	7	6
LIST PRICE:	\$2.5188	\$3.4565	\$2.7098

## PEX SUPPORT, 90 DEGREE BEND

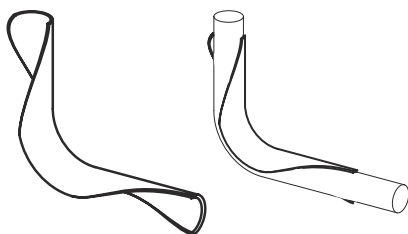

- For 3/8", 1/2", 3/4", and 1" PEX tubing.
- Holds "PEX" tubing firmly to prevent kinking.

- Form slight radius 90 degree bends in PEX tubing.
- Bend support edges are burr free. No sharp edges for PEX to rub against.

PART NUMBER	BS-1-500	BS-1-750-5	BS-1-1000-5
SIZE:	1/2"	3/4"	1"
GUAGE:	18	18	18
FINISH:	Galv. Steel	Galv. Steel	Galv. Steel
CARTON QUANTITY:	50	50	50
WT. PER CARTON (Lbs.)	5	11	14
LIST PRICE:	\$1.4168	\$1.3935	\$2.2210

# LABOR COST SAVINGS TABLE

## C&S MANUFACTURING CORPORATION

1052 S. Neenah Avenue • P.O. Box 736 • Sturgeon Bay, WI 54235

Phone: 920-743-6941 • Fax: 920-743-7432

E-mail: info@bassetproducts.com

Website: www.bassetproducts.com



## BASSET PRODUCTS - DON'T COST, THEY PAY.

### Compare Labor Costs

Use this handy labor graph to determine your actual labor cost. Find the intersection of the time spent and total cost per hour.

Time \$	1 Min.	1 1/2 Min.	2 Min.	2 1/2 Min.	3 Min.	4 Min.	5 Min.	6 Min.	7 Min.	8 Min.	9 Min.	10 Min.
8.00	.13	.20	.27	.33	.40	.53	.67	.80	.93	1.06	1.20	1.33
10.00	.17	.25	.33	.42	.50	.67	.83	1.00	1.16	1.33	1.50	1.67
12.00	.20	.30	.40	.50	.60	.80	1.00	1.20	1.40	1.60	1.80	2.00
14.00	.23	.35	.47	.58	.70	.93	1.17	1.40	1.63	1.87	2.10	2.33
16.00	.27	.40	.53	.67	.80	1.06	1.33	1.60	1.87	2.13	2.40	2.66
18.00	.30	.45	.60	.75	.90	1.20	1.50	1.80	2.10	2.40	2.70	3.00
20.00	.33	.50	.67	.83	1.00	1.33	1.67	2.00	2.33	2.67	3.00	3.33
22.00	.37	.55	.73	.92	1.10	1.47	1.83	2.20	2.57	2.93	3.30	3.67
24.00	.40	.60	.80	1.00	1.20	1.60	2.00	2.40	2.80	3.20	3.60	4.00
26.00	.43	.65	.87	1.08	1.30	1.73	2.17	2.60	3.03	3.46	3.90	4.33
28.00	.47	.70	.93	1.17	1.40	1.87	2.34	2.80	3.27	3.74	4.20	4.67
30.00	.50	.75	1.00	1.25	1.50	2.00	2.50	3.00	3.50	4.00	4.50	5.00
32.00	.53	.80	1.07	1.33	1.60	2.13	2.67	3.20	3.73	4.26	4.80	5.33
34.00	.57	.85	1.13	1.42	1.70	2.27	2.84	3.40	3.97	4.54	5.10	5.67

## LABOR DOES COST YOU

**LABOR IS YOUR MOST EXPENSIVE COST.** Contractors and their employees who spend time looking for scrap pieces to use instead of using proper Basset Hanger, Bracket, Strap or Bar are actually wasting money in time lost. Usually the proper Basset products is less expensive than the cost of the time lost.

# ORDER FORM

## C&S MANUFACTURING CORPORATION

1052 S. Neenah Avenue • P.O. Box 736 • Sturgeon Bay, WI 54235  
Phone: 920-743-6941 • Fax: 920-743-7432  
E-mail: [info@bassetproducts.com](mailto:info@bassetproducts.com)  
Website: [www.bassetproducts.com](http://www.bassetproducts.com)



Date: \_\_\_\_\_

**Bill To:**

Company Name \_\_\_\_\_

Address \_\_\_\_\_

City, State, Zip \_\_\_\_\_

Phone \_\_\_\_\_

**Ship To:**

Company Name \_\_\_\_\_

Address \_\_\_\_\_

City, State, Zip \_\_\_\_\_

Phone \_\_\_\_\_

Item Number	Quantity	Description	List Price (Each)	Total Price

**If you would like samples of any of our products, mark "Samples" in the price box**  
Please Fax to 920-743-7432 or e-mail to [info@bassetproducts.com](mailto:info@bassetproducts.com)



# TERMS & CONDITIONS

The following terms and conditions pertain to qualified customers only. C&S Manufacturing Corporation, at its sole discretion, may qualify or disqualify any customer.

**(01) Credit Terms:**

Cash: Net, thirty (30) days;  
Credit: Discounts shown in Item (02) below will be allowed on bills dated 1st to 15th if paid by the 25th. Bills dated the 16th to the last day of the month if paid by the 10th of the following month.

Past Due: Accounts past due over sixty (60) days will be subject to a late charge of 1 1/2 % per month. Accounts that regularly pay beyond policy terms will be denied open account status.

**(02) Order Discounts:**

The following discounts shall apply:  
No discount on orders below \$1,200.00;  
\$1,200 - \$2,000 - 2% discount 10 days, Net 30;  
\$2,001 - \$3,000 - 3% discount 10 days, Net 30;  
\$3,001 - \$4,000 - 4% discount 10 days, Net 30

**(03) Prices:**

All prices are subject to change without notice.

**(04) Minimum Orders:**

All orders are minimum \$50.00.

**(05) Broken Carton Policy:**

C&S Manufacturing Corporation will add 5% to the total invoiced price for broken carton shipments.

**(06) Full Freight Allowance Policy:**

C&S Manufacturing Corporation will pay full freight on our selected carrier to a single destination within the 48 contiguous states on orders totaling \$1200.00 net or 1000 lbs. C&S Manufacturing Corporation allowance policy applies only on freight shipped from the factory.

**(07) Weights:**

All weights are approximate due to varying thicknesses of steel. C&S Manufacturing Corporation weight measurements or calculations shall be deemed final.

**(08) Shipping Errors:**

C&S Manufacturing Corporation will not be responsible for shipping errors reported ten (10) business days after receipt of product. If a customer receives the wrong merchandise due to an error in order processing or shipping, C&S Manufacturing Corporation will issue an RGA before the merchandise can be returned, unless other arrangements are made. C&S Manufacturing Corporation will be responsible for return freight.

**(09) Shipping Shortages:**

C&S Manufacturing Corporation will not be responsible for shipment shortages that are signed as cleared.

**(10) Order(s) Additions and Changes:**

While we make every effort to ship our product according to your specific instructions, additions or changes to your orders may reach us too late to be implemented. We ship most orders within one working day.

**(11) Returned Goods Authorization (RGA):**

In order to return products or receive warranty service, customers must obtain a Return Goods Authorization (RGA) number. An RGA can be obtained by contacting C&S Manufacturing Corporation by:

**MAIL:** C&S Manufacturing Corporation, Customer Service Department, P.O. Box 736,

Sturgeon Bay, WI 54235;

**PHONE:** 920-743-6941;

**FAX:** 920-743-7432, or;

**EMAIL:** [info@BassetProducts.com](mailto:info@BassetProducts.com)

C&S Manufacturing Corporation will not receive product(s) without a C&S issued RGA number.

In order to be processed, all RGA requests must reference our order number, our invoice number and the customers purchase order number, which must be less than **twelve (12) months old.**

In order to be accepted, all returned material must be in multiples of the stated catalog minimum order quantity and in original condition.

Specials or custom-made product(s) are not considered normal stock and therefore cannot be returned, except in case of manufacturer's defect.

Customers will be charged 10% of invoice price for product(s) restocking. An RGA is invalid if referenced product(s) is not received within ninety (90) days of an RGA issue date. Issuance of the RGA does not authorize the customer to deduct the value of the return once product is received by C&S Manufacturing Corporation and found to be in acceptable condition. C&S Manufacturing Corporation will issue a credit memo for returned product and related expenses (i.e. shipping) when applicable. C&S Manufacturing Corporation reserves the right to deny, nullify or cancel an RGA at its discretion.

**(12) Rust, Corrosion or Ultra-violet degradation exception:**

C&S Manufacturing Corporation will not accept for return, nor issue an RGA for, any product(s) that exhibit the presence of rust, corrosion or tarnishing or material degradation caused by ultra violet light exposure or any other external or internal signs of deterioration of product due to inadequate, careless or improper care, storage, sheltering or protection from the weather and environment.

**(13) Obsolete, Old Design, Unsalable and Damaged exception:**

All returns must be returned prepaid and subject to inspection for damage or misuse prior to issuance of credit. No credit will be allowed for material determined to be over one (1) year old, of obsolete or old design, in unsalable condition or not in standard quantities.

**(14) Standard(s) and Code(s) Conformances:**

C&S Manufacturing Corporation makes no assurances as to code or standards conformance of our product other than that which is printed in this catalog, on original C&S Manufacturing Corporation literature or website, in C&S Manufacturing Corporation paid advertising or identified directly on the product itself. Check with your local C&S Manufacturing Corporation sales representative, code official or call the factory for current code and standards conformance information on our products.

## LIMITED WARRANTY

C&S Manufacturing Corporation warrants that product(s) manufactured by us will be free from defects in material and workmanship for one (1) year from date of shipment and when installed in accordance with good building practices and meeting the detailed requirements of all applicable Federal, State and Local laws, rules, regulations, building standards and codes.

C&S Manufacturing Corporation will, at its option, repair, replace or supply credit to any purchaser of any product(s) that appears, to the Company's satisfaction, to have been defective in material and/or workmanship and is covered by the Company's warranty.

**This warranty shall be effective only if the product:**

**(01)** was installed in accordance with supplied instructions (if any), common installation or use practices and existing federal, state and local building, HVAC and plumbing rules, regulations or codes;

**(02)** has not been subjected to misuse or abuse; **(3)** was properly cared for and stored in a dry location prior to use and does not exhibit any signs of rust, corrosion, tarnishing, ultra-violet light degradation, etc., internal or external, which would degrade the integrity of the product(s)

**(03)** was at all times used in a manner consistent with its intended use;

**(04)** was never modified, altered, or repaired by anyone other than C&S Manufacturing Corporation;

**(05)** was properly subjected to and passed applicable testing methods immediately after the products installation;

**(06)** was not damaged by freezing, corrosion or ultra-violet light (U.V.) degradation and;

**(07)** was never damaged or materially changed by an uncontrollable, outside influenced or natural phenomenon. This warranty excludes all costs arising from routine maintenance, including the replacement of any parts required by such maintenance and the replacement of parts required by normal wear and tear. This warranty does not obligate C&S Manufacturing Corporation to bear any transportation, removal or installation charges in connection with the inspection, repair or replacement of defective parts, other than the cost or cost-equivalent of the defective C&S Manufacturing Corporation manufactured product. C&S Manufacturing Corporation also reserves the right to modify, alter or improve their product(s), or part(s) thereof, at any time without incurring an obligation to notify or modify, alter, improve or replace any product, or parts thereof, previously sold. This warranty is the purchasers exclusive remedy.

**THE WARRANTY PRINTED ABOVE IS THE ONLY WARRANTY APPLICABLE TO THIS PURCHASE.**

**IT IS UNDERSTOOD AND AGREED THAT SELLER'S LIABILITY AND PURCHASER'S SOLE REMEDY, SHALL NOT EXCEED THE RETURN OF THE AMOUNT OF THE PURCHASE PRICE PAID BY THE PURCHASER, AND UNDER NO CIRCUMSTANCES SHALL SELLER BE LIABLE FOR ANY AND ALL SPECIAL, INCIDENTAL OR CONSEQUENTIAL DAMAGES.**

**SELLER WILL NOT BE LIABLE FOR ANY DAMAGES, LOSSES OR EXPENSES AS A RESULT OF PURCHASER'S NEGLIGENCE, WHETHER DEEMED ACTIVE OR PASSIVE, AND WHETHER OR NOT ANY SUCH NEGLIGENCE IS THE SOLE CAUSE OF ANY SUCH DAMAGE, LOSS OR EXPENSE.**

# SALES REP MAP

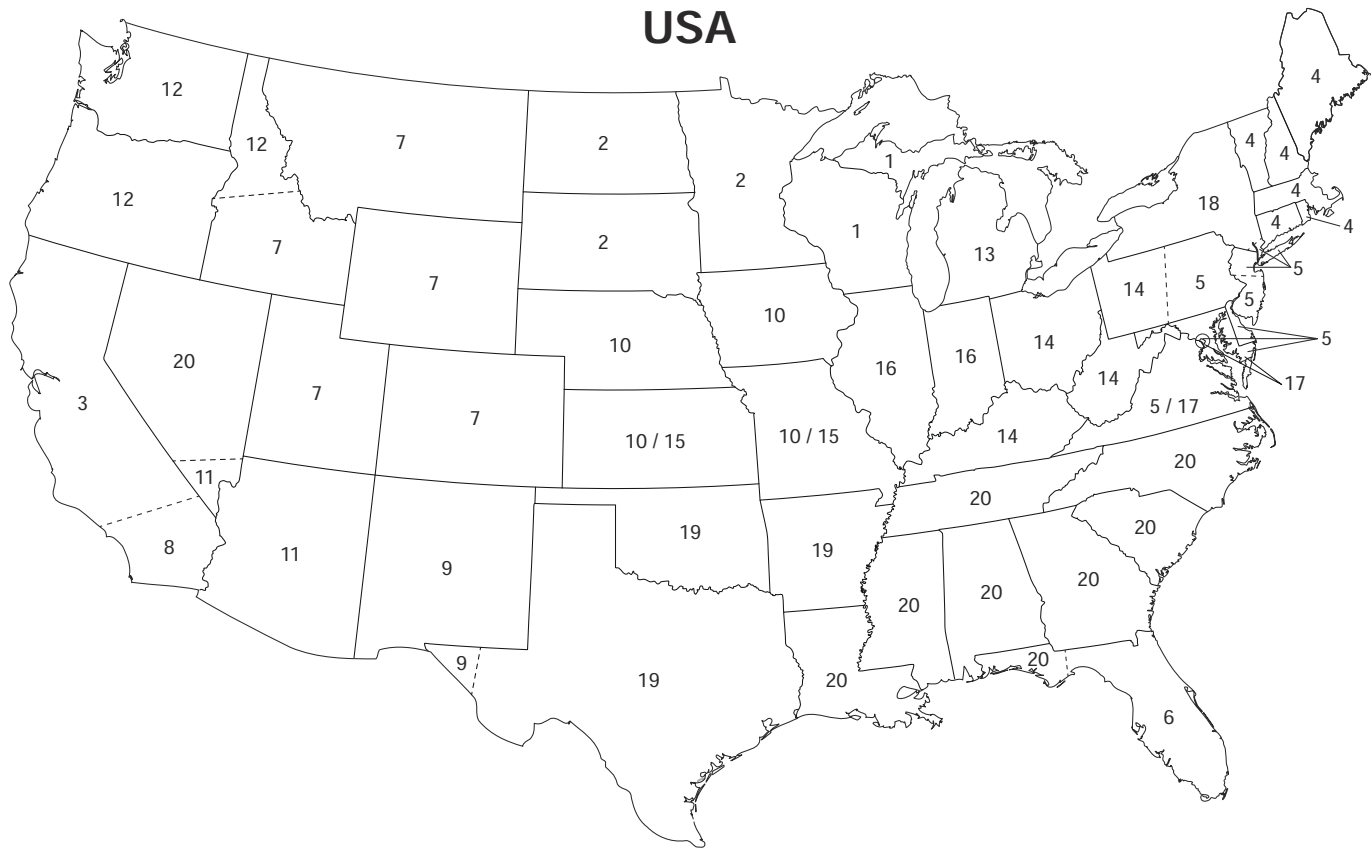

## BASSET PRODUCTS SALES REPS

	Company Name	Area Represented	Phone
1.	BBW Sales Inc	WI, MI (Upper0)	262-783-6223
2.	Bennerotte Marketing Agency	MN, ND, SD	763-544-8611
3.	Capri Sales	CA (North)	916-640-0252
4.	Fourms LLC	MA, CT, RI, VT, NH, ME	860-365-9709
5.	T&S Industries	PA (East), DE, DC, N.J. (South), MD (Plumbing), VA (Plumbing) NYC (Long Island), N.J. (North)	609-314-0862
6.	Jack Murray & Assoc.	FL (No Panhandle)	727-724-1715
7.	Jensen Sales & Mktg	CO, ID (South), MT, UT, WY	801-746-4476
8.	LSP Industries	CA (South)	805-706-0391
9.	M&M Sales Inc.	NM, TX (El Paso region )	505-884-1733
10.	Mack McClain & Assoc.	IA, NE, KS (Plumbing), MO (Plumbing)	913-339-6677
11.	New Horizons	AZ, NV (South)	602-437-4795
12.	Norpac Inc.	OR, WA, AK, ID (North)	253-850-8800
13.	Pro Sales	MI (Lower)	866-649-8430
14.	RA Benedict Sales Co.	KY, OH, WV, PA (West)	724-836-0278
15.	Repko Sales	KS (Heating), MO (Heating)	913-831-9743
16.	Richard Specialty	IL, IN	773-725-2907
17.	Richmond Marketing Inc. (RMI)	MD, DC, VA (Plumbing)	804-643-7355
18.	TIA Sales	NY (no NYC & Long Island)	716-652-8520
19.	Westway Sales Inc.	TX (no El Paso), AR, OK	800-822-9514
20.	Contact C&S Manufacturing directly.		800-959-0374

## C&S MANUFACTURING CORPORATION

---

1052 S. Neenah Avenue • P.O. Box 736 • Sturgeon Bay, WI 54235  
Phone: 920-743-6941 • Fax: 920-743-7432  
E-mail: [info@bassetproducts.com](mailto:info@bassetproducts.com)  
Website: [www.bassetproducts.com](http://www.bassetproducts.com)



**C&S Manufacturing also produces custom orders. Our capabilities include:**

---

### STEEL SLITTING

---

A complete custom steel slitting facility is in house and available to you. We can also provide Round Edging, Blanking and Cut-to-Length services.

---

### PRESSES

---

Our large bed presses are capable of single piece stamping or progressive step stamping for maximum production at minimum cost.

---

### PLASTIC INJECTION MACHINE

---

C&S Manufacturing Corporation has Plastic Injection Molding equipment to satisfy all your custom molding

Our experienced veteran work force, averaging nearly 10 years of service, along with our wide range of capabilities for high-speed presses to four-slide and multi-side machines, welding, finishing, to maintenance and warehousing can assure satisfaction to our OEM customers on their long and short run needs as well as "Just In Time" delivery with confidence.

Among the many fine stampings C&S has produced are motor starting capacitor cases and covers, conduit boxes and covers, clamps, component mounting clamps, centrifugal switch guards, fan guards, motor

**Inquire at [info@bassetproducts.com](mailto:info@bassetproducts.com) or call 1-800-959-0374 for a quote.**

# PRODUCTS NUMBER INDEX

112THS-CNN.....	300-07	14THS-CNN.....	300-07	34THS-GNN.....	300-07
112THS-CWN.....	300-07	14THS-CWN.....	300-07	34THS-GWN.....	300-07
112THS-GNN.....	300-07	14THS-GNN.....	300-07	34THS-PCNN.....	300-07
112THS-GWN.....	300-07	14THS-GWN.....	300-07	34THS-PCWN.....	300-07
112THS-PCNN.....	300-07	14THS-PCNN.....	300-07	34X212-11PWC.....	300-16
112THS-PCWN.....	300-07	14THS-PCWN.....	300-07	34X212-11PWS.....	300-16
112X4-11PWC.....	300-15	1816-503.....	200-01	34X4-11PWC.....	300-15
112X4-11PWP.....	300-15	1818-503.....	200-01	34X4-11PWP.....	300-15
112X4-11PWS.....	300-15	1820-503.....	200-01	34X4-11PWS.....	300-15
112X4-9PWC.....	300-14	1THS-CNN.....	300-07	34X4-9PWC.....	300-14
112X4-9PWP.....	300-14	1THS-CWN.....	300-07	34X4-9PWP.....	300-14
112X4-9PWS.....	300-14	1THS-GNN.....	300-07	34X4-9PWS.....	300-14
112X6-11PWC.....	300-16	1THS-GWN.....	300-07	34X6-11PWC.....	300-16
112X6-11PWP.....	300-16	1THS-PCNN.....	300-07	34X6-11PWP.....	300-16
112X6-11PWS.....	300-16	1THS-PCWN.....	300-07	34X6-11PWS.....	300-16
112X6-9PWC.....	300-14	1X212-11PWC.....	300-16	34X6-9PWC.....	300-14
112X6-9PWP.....	300-14	1X212-11PWS.....	300-16	34X6-9PWP.....	300-14
112X6-9PWS.....	300-14	1X4-11PWC.....	300-15	34X6-9PWS.....	300-14
112X8-9PWC.....	300-15	1X4-11PWP.....	300-15	34X8-9PWC.....	300-15
112X8-9PWP.....	300-15	1X4-11PWS.....	300-15	34X8-9PWP.....	300-15
112X8-9PWS.....	300-15	1X4-9PWC.....	300-14	34X8-9PWS.....	300-15
114THS-CNN.....	300-07	1X4-9PWP.....	300-14	34ZJH.....	300-06
114THS-CWN.....	300-07	1X4-9PWS.....	300-14	3516-503.....	200-01
114THS-GNN.....	300-07	1X6-11PWC.....	300-16	3516-506.....	200-01
114THS-GWN.....	300-07	1X6-11PWP.....	300-16	3518-503.....	200-01
114THS-PCNN.....	300-07	1X6-11PWS.....	300-16	3616-503.....	200-01
114THS-PCWN.....	300-07	1X6-9PWC.....	300-14	3616-506.....	200-01
114X4-11PWC.....	300-15	1X6-9PWP.....	300-14	3618-503.....	200-01
114X4-11PWP.....	300-15	1X6-9PWS.....	300-14	380-5.....	300-10
114X4-11PWS.....	300-15	1X8-9PWC.....	300-15	38THS-CNN.....	300-07
114X4-9PWC.....	300-14	1X8-9PWP.....	300-15	38THS-CWN.....	300-07
114X4-9PWP.....	300-14	1X8-9PWS.....	300-15	38THS-GNN.....	300-07
114X4-9PWS.....	300-14	212THS-GNN.....	300-07	38THS-GWN.....	300-07
114X6-11PWC.....	300-16	212THS-GWN.....	300-07	38THS-PCNN.....	300-07
114X6-11PWP.....	300-16	212THS-PCNN.....	300-07	38THS-PCWN.....	300-07
114X6-11PWS.....	300-16	212THS-PCWN.....	300-07	3THS-GNN.....	300-07
114X6-9PWC.....	300-14	2416-503.....	200-01	3THS-GWN.....	300-07
114X6-9PWP.....	300-14	2418-503.....	200-01	3THS-PCNN.....	300-07
114X6-9PWS.....	300-14	2420-503.....	200-01	3THS-PCWN.....	300-07
114X8-9PWC.....	300-15	2516-503.....	200-01	400S.....	300-19
114X8-9PWP.....	300-15	2518-503.....	200-01	416-503.....	200-01
114X8-9PWS.....	300-15	2616-503.....	200-01	418-503.....	200-01
1216-503.....	200-01	2618-503.....	200-01	420-503.....	200-01
1218-503.....	200-01	2THS-CNN.....	300-07	425B.....	300-19
1220-503.....	200-01	2THS-CWN.....	300-07	4THS-GNN.....	300-07
12CJH.....	300-06	2THS-GNN.....	300-07	4THS-GWN.....	300-07
12PCJH.....	300-06	2THS-GWN.....	300-07	4THS-PCNN.....	300-07
12THS-CNN.....	300-07	2THS-PCNN.....	300-07	4THS-PCWN.....	300-07
12THS-CWN.....	300-07	2THS-PCWN.....	300-07	500-5.....	300-10
12THS-GNN.....	300-07	300S.....	300-19	516-501.....	200-01
12THS-GWN.....	300-07	316-501.....	200-01	516-503.....	200-01
12THS-PCNN.....	300-07	316-503.....	200-01	516-504.....	200-01
12THS-PCWN.....	300-07	316-503H.....	200-01	518-501.....	200-01
12X212-11PWC.....	300-16	316-504.....	200-01	518-502.....	200-01
12X212-11PWS.....	300-16	318-501.....	200-01	518-503.....	200-01
12X4-11PWC.....	300-15	318-502.....	200-01	518-504.....	200-01
12X4-11PWP.....	300-15	318-503.....	200-01	520-501.....	200-01
12X4-11PWS.....	300-15	318-503H.....	200-01	520-502.....	200-01
12X4-9PWC.....	300-14	318-504.....	200-01	520-503.....	200-01
12X4-9PWP.....	300-14	320-501.....	200-01	520-504.....	200-01
12X4-9PWS.....	300-14	320-502.....	200-01	600S.....	300-19
12X6-11PWC.....	300-16	320-503.....	200-01	616-501.....	200-01
12X6-11PWP.....	300-16	320-503H.....	200-01	616-503.....	200-01
12X6-11PWS.....	300-16	320-504.....	200-01	616-504.....	200-01
12X6-9PWC.....	300-14	325B.....	300-19	618-501.....	200-01
12X6-9PWP.....	300-14	3316-503.....	200-01	618-502.....	200-01
12X6-9PWS.....	300-14	3318-503.....	200-01	618-503.....	200-01
12X8-9PWC.....	300-15	34CJH.....	300-06	618-504.....	200-01
12X8-9PWP.....	300-15	34PCJH.....	300-06	620-501.....	200-01
12X8-9PWS.....	300-15	34THS-CNN.....	300-07	620-502.....	200-01
12ZJH.....	300-06	34THS-CWN.....	300-07	620-503.....	200-01

# PRODUCTS NUMBER INDEX

620-504 .....	200-01	BRH-3 .....	300-13	DS10-10-28G-58 .....	200-04
800S .....	300-19	BRH-34 .....	300-13	DS25-6-20B .....	200-04
816-503 .....	200-01	BRH-4 .....	300-13	DS25-6-20G .....	200-04
818-503 .....	200-01	BS-1-1000-5 .....	400-02	DS25-6-22B .....	200-04
820-503 .....	200-01	BS-1-500 .....	400-02	DS25-6-24B .....	200-04
916-503 .....	200-01	BS-150-16 .....	200-03	DS25-6-24C .....	200-04
A-125 .....	100-01	BS-150-18 .....	200-03	DS25-6-24G .....	200-04
A-125H .....	100-01	BS-1-750-5 .....	400-02	DS25-6-28G .....	200-04
A-125-P .....	400-01	BS-300-16 .....	200-03	DS25-6-28G-58 .....	200-04
A-150 .....	100-01	BS-300-18 .....	200-03	DS-3 .....	100-02
AB 42 .....	300-04	BS-450-16 .....	200-03	DS50-1-20B .....	200-04
AB 46 .....	300-04	BS-450-18 .....	200-03	DS50-1-20G .....	200-04
AB-218 .....	100-01	BSC-1P-5 .....	300-06	DS50-1-22B .....	200-04
AB-222 .....	100-01	BSC-2P-5 .....	300-06	DS50-1-24B .....	200-04
AB-318 .....	100-01	BSC-3P-5 .....	300-06	DS50-1-24C .....	200-04
AMB-1 .....	300-05	C-125 .....	100-01	DS50-1-24G .....	200-04
AMB-1C .....	300-05	C-125H .....	100-01	DS50-1-28G .....	200-04
AT-125 .....	100-01	CHLG-112-5 .....	300-08	DS50-1-28G-58 .....	200-04
AT-125H .....	100-01	CHLG-114-5 .....	300-08	DWV-112-5 .....	300-12
AT-125-P .....	400-01	CHLG-12-5 .....	300-08	DWV-112-P-5 .....	300-12
AT-150 .....	100-01	CHLG-1-5 .....	300-08	DWV-2-5 .....	300-12
ATS-125 .....	100-01	CHLG-212-5 .....	300-08	DWV-2-P-5 .....	300-12
ATS-125H .....	100-01	CHLG-2-5 .....	300-08	DWV-3-5 .....	300-12
ATS-150 .....	100-01	CHLG-34-5 .....	300-08	DWV-3-P-5 .....	300-12
AWHP-20-5 .....	300-19	CHLG-3-5 .....	300-08	DWV-4-5 .....	300-12
AWHP-22-5 .....	300-19	CHLG-4-5 .....	300-08	DWV-4-P-5 .....	300-12
AWHP-24-5 .....	300-19	CHLS-112-5 .....	300-08	E-125C .....	100-01
AWHP-26-5 .....	300-19	CHLS-114-5 .....	300-08	E-125G .....	100-01
AWHP-30-5 .....	300-19	CHLS-12-5 .....	300-08	E-125-P .....	400-01
AWHPC-20-5 .....	300-19	CHLS-1-5 .....	300-08	ET-125C .....	100-01
AWHPC-22-5 .....	300-19	CHLS-212-5 .....	300-08	ET-125G .....	100-01
AWHPC-24-5 .....	300-19	CHLS-2-5 .....	300-08	ET-125-P .....	400-01
AWHPC-26-5 .....	300-19	CHLS-34-5 .....	300-08	ETS-125C .....	100-01
AWHPC-30-5 .....	300-19	CHLS-3-5 .....	300-08	ETS-125G .....	100-01
BBC-5 .....	300-10	CHLS-4-5 .....	300-08	ETSP-5 .....	300-05
BBH-1000 .....	300-12	CT-125 .....	100-01	FB 44 .....	300-04
BBH-1000-D .....	300-12	CT-125H .....	100-01	FDS-12 .....	100-02
BBH-1000-P .....	300-12	CTS-125 .....	100-01	FDS-9 .....	100-02
BBH-500 .....	300-12	CTS-125H .....	100-01	FHA-100-1212-4 .....	200-02
BBH-500-D .....	300-12	DH12-34-5 .....	300-06	FHA-100-1212-6 .....	200-02
BBH-500-P .....	300-12	DS100-1-20B .....	200-04	FHA-100-1212-8 .....	200-02
BBH-750 .....	300-12	DS100-1-20G .....	200-04	FHA-100-1214-4 .....	200-02
BBH-750-D .....	300-12	DS100-1-22B .....	200-04	FHA-100-1214-6 .....	200-02
BBH-750-P .....	300-12	DS100-1-24B .....	200-04	FHA-100-1214-8 .....	200-02
BCB-C .....	300-03	DS100-1-24C .....	200-04	FHA-100-1216-4 .....	200-02
BCB-G .....	300-03	DS100-1-24G .....	200-04	FHA-100-1216-6 .....	200-02
BD10-10-30B .....	200-05	DS100-1-28G .....	200-04	FHA-100-1216-8 .....	200-02
BD10-10-30G .....	200-05	DS100-1-28G-58 .....	200-04	FHA-100-1218-4 .....	200-02
BD1-100-26G-112 .....	200-05	DS100-5-20B .....	200-04	FHA-100-1218-6 .....	200-02
BD1-100-26G-112H .....	200-05	DS100-5-20G .....	200-04	FHA-100-1218-8 .....	200-02
BD1-100-28G-112 .....	200-05	DS100-5-20G .....	200-04	FHA-100-1218-8 .....	200-02
BD1-100-28G-112H .....	200-05	DS100-5-22B .....	200-04	FHA-100-1618-4 .....	200-02
BD1-100-30B .....	200-05	DS100-5-24B .....	200-04	FHA-100-1618-6 .....	200-02
BD1-100-30G .....	200-05	DS100-5-24C .....	200-04	FHA-100-1618-8 .....	200-02
BD1-80-26G-112 .....	200-05	DS100-5-24G .....	200-04	FHA-100-1812-4 .....	200-02
BD1-80-26G-112H .....	200-05	DS100-5-28G .....	200-04	FHA-100-1812-6 .....	200-02
BD1-80-26G-112H .....	200-05	DS100-5-28G-58 .....	200-04	FHA-100-1812-8 .....	200-02
BD1-80-28G-112 .....	200-05	DS10-100-20B .....	200-04	FHA-100-1814-4 .....	200-02
BD1-80-28G-112H .....	200-05	DS10-100-20G .....	200-04	FHA-100-1814-6 .....	200-02
BH-10 .....	100-02	DS10-100-22B .....	200-04	FHA-100-1814-8 .....	200-02
BH-11 .....	100-02	DS10-100-24B .....	200-04	FHA-100-1816-4 .....	200-02
BH-12 .....	100-02	DS10-100-24C .....	200-04	FHA-100-1816-6 .....	200-02
BH-2 .....	100-02	DS10-100-24G .....	200-04	FHA-100-1816-8 .....	200-02
BH-8 .....	100-02	DS10-100-28G .....	200-04	FHA-100-1818-4 .....	200-02
BH-9 .....	100-02	DS10-100-28G-58 .....	200-04	FHA-100-1818-6 .....	200-02
BHS-1P-5 .....	300-06	DS10-10-20B .....	200-04	FHA-100-1818-8 .....	200-02
BHS-2P-5 .....	300-06	DS10-10-20G .....	200-04	FHA-100-2412-4 .....	200-02
BHS-3P-5 .....	300-06	DS10-10-22B .....	200-04	FHA-100-2412-6 .....	200-02
BRH-1 .....	300-13	DS10-10-24B .....	200-04	FHA-100-2412-8 .....	200-02
BRH-112 .....	300-13	DS10-10-24C .....	200-04	FHA-100-2414-4 .....	200-02
BRH-12 .....	300-13	DS10-10-24G .....	200-04	FHA-100-2414-6 .....	200-02
BRH-2 .....	300-13	DS10-10-28G .....	200-04	FHA-100-2414-8 .....	200-02



# PRODUCTS NUMBER INDEX

FHA-100-2416-4.....	200-02	HY12V-5.....	300-01	PS10-100-24C.....	200-04
FHA-100-2416-6.....	200-02	HY34H-5.....	300-01	PS10-100-24G.....	200-04
FHA-100-2416-8.....	200-02	HY34H-CPVC-5.....	300-01	PS10-100-28G.....	200-04
FHA-100-2418-4.....	200-02	HY34V-5.....	300-01	PS10-10-20B.....	200-04
FHA-100-2418-6.....	200-02	HZ-5.....	300-11	PS10-10-20G.....	200-04
FHA-100-2418-8.....	200-02	IPC-100-5.....	300-10	PS10-10-22B.....	200-04
FHA-100-2816-4.....	200-02	IPC-12-5.....	300-10	PS10-10-24B.....	200-04
FHA-100-2816-6.....	200-02	IPC-34-5.....	300-10	PS10-10-24C.....	200-04
FHA-100-2816-8.....	200-02	IS-18.....	300-02	PS10-10-24G.....	200-04
FHA-100-3218-4.....	200-02	IS-20.....	300-02	PS10-10-28G.....	200-04
FHA-100-3218-6.....	200-02	IS-26.....	300-02	PS-10120.....	300-02
FHA-100-3218-8.....	200-02	IT-50-5.....	100-01	PS-10120-R.....	300-02
FHA-100-612.....	200-02	LSB-1US-5.....	300-10	PS-10126.....	300-02
FHA-100-614.....	200-02	MS-18.....	300-01	PS-10720.....	300-02
FHA-100-616.....	200-02	MS-20.....	300-01	PS-10726.....	300-02
FHA-100-618.....	200-02	MS-26.....	300-01	PS-2.....	300-01
FHA-100-912-4.....	200-02	MS-500-18.....	300-01	PS25-6-20B.....	200-04
FHA-100-912-6.....	200-02	MS-500-20.....	300-01	PS25-6-20G.....	200-04
FHA-100-912-8.....	200-02	MS-500-26.....	300-01	PS25-6-22B.....	200-04
FHA-100-914-4.....	200-02	P-1000-5.....	300-07	PS25-6-24B.....	200-04
FHA-100-914-6.....	200-02	P3125-16SN.....	200-03	PS25-6-24C.....	200-04
FHA-100-914-8.....	200-02	P3126-16-R.....	200-03	PS25-6-24G.....	200-04
FHA-100-916-4.....	200-02	P3126-16SN.....	200-03	PS25-6-28G.....	200-04
FHA-100-916-6.....	200-02	P3128-16SN.....	200-03	PS50-1-20B.....	200-04
FHA-100-916-8.....	200-02	P-500-5.....	300-07	PS50-1-20G.....	200-04
FHA-100-918-4.....	200-02	P58-16-R.....	200-03	PS50-1-22B.....	200-04
FHA-100-918-6.....	200-02	P58-16SN.....	200-03	PS50-1-24B.....	200-04
FHA-100-918-8.....	200-02	P66-16-R.....	200-03	PS50-1-24C.....	200-04
FHA-200.....	200-02	P68-16-R.....	200-03	PS50-1-24G.....	200-04
FHA-28-30.....	200-03	P68-16SN.....	200-03	PS50-1-28G.....	200-04
FHA-28-50.....	200-03	P-750-5.....	300-07	PSB-500.....	400-02
FHA-300-1216.....	200-02	P812-16-R.....	200-03	PSB-500P.....	400-02
FHA-300-1218.....	200-02	PBAT-1-5.....	200-03	PSB-750.....	400-02
FHA-300-1816.....	200-02	PCS-112-5.....	300-08	PTS-1000B-5.....	400-01
FHA-300-1816-8.....	200-02	PCS-114-5.....	300-08	PTS-1000R-5.....	400-01
FHA-300-1818.....	200-02	PCS-1-5.....	300-08	PTS-1000W-5.....	400-01
FHA-300-2416-8.....	200-02	PCS-212-5.....	300-08	PTS-500B-5.....	400-01
FHA-300-612.....	200-02	PCS-2-5.....	300-08	PTS-500R-5.....	400-01
FHA-300-616.....	200-02	PCS-3-5.....	300-08	PTS-500W-5.....	400-01
FHA-300-912.....	200-02	PCS-4-5.....	300-08	PTS-750B-5.....	400-01
FHA-300-916.....	200-02	PCS-6-5.....	300-08	PTS-750R-5.....	400-01
FHA-312-1816.....	200-02	PHS-1-5.....	200-05	PTS-750W-5.....	400-01
FHA-400-1816.....	200-02	PHS-20-5.....	200-05	QSK-1.....	300-18
FHA-400-2416.....	200-02	PI 12CPVC-5.....	300-04	QSK-150.....	300-18
FHA-40-30.....	200-03	PI 34CPVC-5.....	300-04	RCGS-112-5.....	300-08
FHA-40-50.....	200-03	PI1000-5.....	300-04	RCGS-114-5.....	300-08
FHA-500-1816-6.....	200-03	PI500-5.....	300-04	RCGS-1-5.....	300-08
FHA-500-1816-8.....	200-03	PI750-5.....	300-04	RCGS-212-5.....	300-08
FHA-500-1816-8S.....	200-03	PMC-BM12-5.....	400-01	RCGS-2-5.....	300-08
FHA-52-30.....	200-03	PMC-SO12-5.....	400-01	RCGS-3-5.....	300-08
FHA-52-50.....	200-03	PMC-SO34-5.....	400-01	RCGS-4-5.....	300-08
FSW-1-5.....	200-05	PPB.....	300-03	RCGS-6-5.....	300-08
FSW-3-5.....	200-05	PS-1.....	300-01	RCHS-112-5.....	300-08
FTNC.....	300-06	PS100-1-20B.....	200-04	RCHS-114-5.....	300-08
FTNC1.....	300-06	PS100-1-20G.....	200-04	RCHS-1-5.....	300-08
FTNPC.....	300-06	PS100-1-22B.....	200-04	RCHS-212-5.....	300-08
FTNPC1.....	300-06	PS100-1-24B.....	200-04	RCHS-2-5.....	300-08
FTNZ.....	300-06	PS100-1-24C.....	200-04	RCHS-3-5.....	300-08
FTNZ1.....	300-06	PS100-1-24G.....	200-04	RCHS-4-5.....	300-08
GWS-412.....	100-02	PS100-1-28G.....	200-04	RCHS-6-5.....	300-08
GWS-49.....	100-02	PS100-5-20B.....	200-04	RF-BM138-5.....	300-11
HP-5.....	300-11	PS100-5-20G.....	200-04	RF-BM21238-5.....	300-11
HP-500.....	400-02	PS100-5-22B.....	200-04	RF-BM238-5.....	300-11
HP-750.....	400-02	PS100-5-24B.....	200-04	RF-SM238-5.....	300-11
HPA-500.....	400-02	PS100-5-24C.....	200-04	SBT-125.....	200-05
HPA-750.....	400-02	PS100-5-24G.....	200-04	SC-100A-5.....	300-09
HY-118.....	300-01	PS100-5-28G.....	200-04	SC-101A-5.....	300-09
HY-120.....	300-01	PS10-100-20B.....	200-04	SC-102A-5.....	300-09
HY-126.....	300-01	PS10-100-20G.....	200-04	SC-103A-5.....	300-09
HY12H-5.....	300-01	PS10-100-22B.....	200-04	SC-104A-5.....	300-09
HY12H-CPVC-5.....	300-01	PS10-100-24B.....	200-04	SC-105A-5.....	300-09

# PRODUCTS NUMBER INDEX

SC-106A-5.....	300-09	TH-2.....	300-10
SC-107A-5.....	300-09	TPC-1P-5.....	300-06
SC-108A-5.....	300-09	TPC-2P-5.....	300-06
SC-109A-5.....	300-09	TPC-3P-5.....	300-06
SC-110A-5.....	300-09	TRC-38118-5.....	300-11
SC-111A-5.....	300-09	TRP-5.....	300-11
SC-112A-5.....	300-09	TRZ-5.....	300-11
SC-1P-5.....	300-06	TS-1238-5.....	300-11
SC-2P-5.....	300-06	TS-12-5.....	300-06
SC-3P-5.....	300-06	TS-238-5.....	300-11
SCQ-100.....	300-05	TS-338-5.....	300-11
SCQ-12.....	300-05	TS-34-5.....	300-06
SCQ-34.....	300-05	TS-438-5.....	300-11
SCR-12.....	300-05	TS-638-5.....	300-11
SCR-34.....	300-05	UC-100-5.....	200-05
SH-1.....	300-13	UPH-10W-5.....	300-12
SH-112.....	300-13	UPH-14W-5.....	300-12
SH-114.....	300-13	UPH-26W-5.....	300-12
SH-12.....	300-13	WCB.....	300-03
SH-2.....	300-13	WCB-G.....	300-04
SH-3.....	300-13	WCB-GM.....	300-04
SH-34.....	300-13	WCB-M.....	300-03
SH-4.....	300-13	WCR-L.....	300-19
SMS-112-5.....	300-08	WCR-NL.....	300-19
SMS-114-5.....	300-08	WHP-24-5.....	300-19
SMS-1-5.....	300-08	WHP-26-5.....	300-19
SMS-2-5.....	300-08	WHP-30-5.....	300-19
SMS-34-5.....	300-08	WHPC-20-5.....	300-19
SOS-112-5.....	300-08	WHPC-22-5.....	300-19
SOS-114-5.....	300-08	WHPC-24-5.....	300-19
SOS-1-5.....	300-08	WHPC-26-5.....	300-19
SOS-2-5.....	300-08	WHPC-30-5.....	300-19
SOS-34-5.....	300-08	WHS-1.....	300-17
SRC.....	300-18	WHS-1EN.....	300-18
SRF-100-5.....	300-09	WHS-1FA.....	300-17
SRF-112-5.....	300-09	WHS-1FAEN.....	300-18
SRF-114-5.....	300-09	WHS-1SP.....	300-17
SRF-12-5.....	300-09	WHS-2.....	300-17
SRF-200-5.....	300-09	WMP-1-5.....	300-19
SRF-212-5.....	300-09	WP-5.....	300-11
SRF-300-5.....	300-09	WZ-5.....	300-11
SRF-34-5.....	300-09		
SRF-400-5.....	300-09		
SRR-100-5.....	300-09		
SRR-112-5.....	300-09		
SRR-114-5.....	300-09		
SRR-12-5.....	300-09		
SRR-200-5.....	300-09		
SRR-212-5.....	300-09		
SRR-300-5.....	300-09		
SRR-34-5.....	300-09		
SRR-400-5.....	300-09		
SRS-112-5.....	300-08		
SRS-114-5.....	300-08		
SRS-12-5.....	300-08		
SRS-1-5.....	300-08		
SRS-212-5.....	300-08		
SRS-2-5.....	300-08		
SRS-34-5.....	300-08		
SRS-3-5.....	300-08		
SRS-4-5.....	300-08		
SSA1-12.....	400-01		
SSA1-34.....	400-01		
SSAT-12.....	400-01		
SSAT-34.....	400-01		
SSC-12.....	400-01		
SSC-34.....	400-01		
SSC-5.....	300-19		
SSLR.....	300-05		
SSRP.....	200-03		
TH-1.....	300-10		



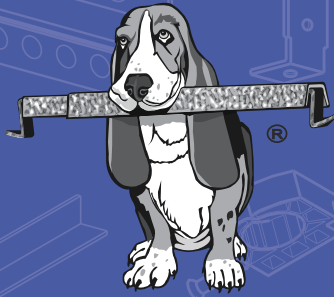

# C & S Manufacturing Corporation



Founded 1962

Labor is your most expensive cost.....  
**BASSET HANGERS DON'T COST, THEY PAY.**



**C & S MANUFACTURING CORPORATION**

P.O. BOX 736 • 1052 S. NEENAH AVENUE • STURGEON BAY, WI 54235

Phone: 800-959-0374 • Fax: 920-743-7432 • E-mail: [info@BassetProducts.com](mailto:info@BassetProducts.com) • Website: [bassetproducts.com](http://bassetproducts.com)

Catalog #01-13