

**THIS SPACE FOR DESIGNER/ENGINEER APPROVAL**

Job/Customer _____	Date _____	Contractor _____
Model Specified _____	Qty _____	Approved By _____
Designer/Engineer _____	Date _____	Contractor's PO# _____
Submitted by _____	Date _____	Other _____

# 4544 Series

**Tankless Water Heater Service Valve Kits**  
**Hot & Cold Set of Full Port Forged Brass Ball Valves**  
**w/ Hi-Flow Hose Drains, Adjustable Pressure Relief Valve Outlet**  
**& Adjustable Packing Gland**

**IPS Union x IPS**  
**500 WOG**  
**ISO 9001**



LEAD FREE  
**CLEAN BRASS**  
THE CLEAR CHOICE FOR THE PROFESSIONAL

Standard brass products conform to NSF/ANSI 61-8  
 Lead free products are certified to NSF/ANSI 61 & NSF/ANSI 372

STANDARD BRASS ITEM #	LEAD FREE ITEM#	SIZE	CTN	CASE	A	B (COLD)	B (HOT)	C	D	E	F	G
<b>RESIDENTIAL PRESSURE RELIEF VALVE (150 PSI/200,000 BTU)</b>												
45443PR	45443WPR	3/4	1	10	3/4	4 1/4	5 7/8	1 5/8	2 5/8	2 3/4	3/4	1/2
<b>RESIDENTIAL PRESSURE RELIEF VALVE (30 PSI/510,000 BTU)</b>												
45443PR3	45443WPR3	3/4	1	10	3/4	4 1/4	5 7/8	1 5/8	2 5/8	2 3/4	3/4	1/2
<b>COMMERCIAL PRESSURE RELIEF VALVE (150 PSI/2,703,000 BTU) &amp; 3/4" CLOSE NIPPLE</b>												
45443PR2	45443WPR2	3/4	1	6	3/4	4 1/4	5 7/8	1 5/8	2 5/8	2 3/4	3/4	1/2

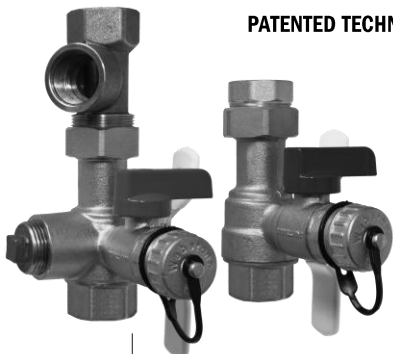

**PATENTED TECHNOLOGY**

TEMP °F	PSI
100	500
150	408
180	398

NO.	DESCRIPTION	MATERIAL
1	BODY	BRASS
2	SEATS	PTFE
3	BALL	BRASS HCP
4	HANDLE NUT	STAINLESS STEEL
5	WING STYLE "T" HANDLE	STEEL CP
6	HANDLE JACKET	VINYL
7	PACKING GLAND	BRASS
8	STEM SEAL	PTFE
9	STEM	BRASS
10	END CAP	BRASS
11	UNION NUT	BRASS
12	RETAINING RING	STAINLESS STEEL
13	UNION FITTING	BRASS
14	WASHER	EPDM
15	DRAIN VALVE HANDLE	ENAMEL COATED ALUMINUM
16	DRAIN VALVE HANDLE SCREW	BRASS
17	CAP & STRAP	BRASS W/ EPDM HOSE WASHER & STRAP
18	RELOCATION ADAPTER (HOT)	BRASS

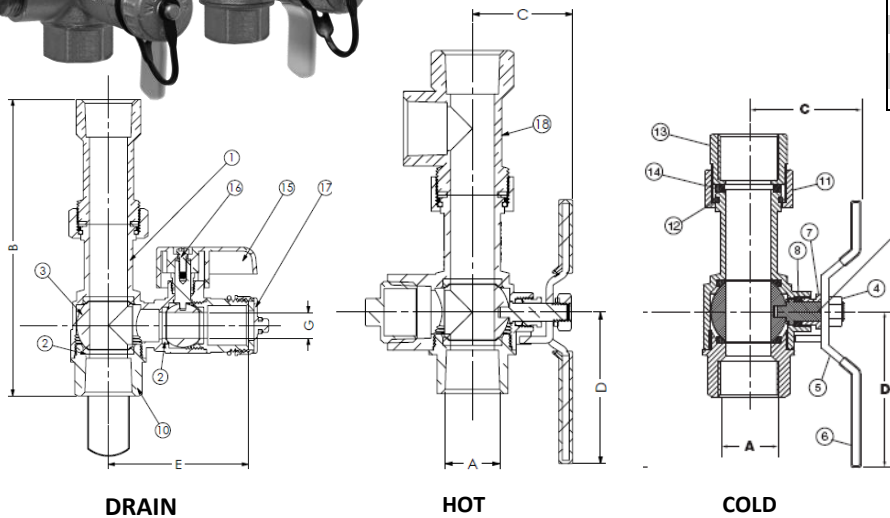

Included w/ 4544PR & PR3	Included w/ 4544PR2
<p><b>Residential Pressure Relief Valve</b>                      Available in 150 PSI / 200,000 btu or 30 PSI / 510,000 btu</p>	<p><b>Commercial Pressure Relief Valve</b>                      150 PSI / 2,703,000 btu &amp; 3/4" Close Nipple</p>

**Specifications:** Designed for residential or commercial use with potable water. This approved Webstone valve is actuated by a blowout proof stem and features an adjustable packing gland. Threaded ends comply with ANSI B1.20.1.



Quality and Commitment Since 1954

www.webstonevalves.com · P: (800) 225-9529 · F: (800) 336-5133

Webstone product specifications in U.S. customary units are approximate and are provided for reference only. Webstone reserves the right to change or modify product design, construction, specifications or materials without prior notice and without incurring any obligation to make such changes and modifications on Webstone products previously or subsequently sold.

4544-4544Wspec\_031914