

VCZA,B,M,N Series Cartridge Valve for Use with VC Series

The VC hydronic valve consists of a valve body and replaceable characterized cartridge assembly.

Depending on the valve model selected, they can be used with a VC2114 or VC8114 series actuator to provide on-off flow control, or with a VC6930 or VC7930 series actuator to provide proportional flow control. Two way bodies may be plumbed in either direction. Three-way bodies may be used in either diverting or mixing applications.

Replacing the cartridge rebuilds the valve. The valve body should be able to stay in the pipes indefinitely.

VC actuators, ordered separately, use cam-operated cartridge travel to resist water hammer. Limit switches prevent motor overrun.

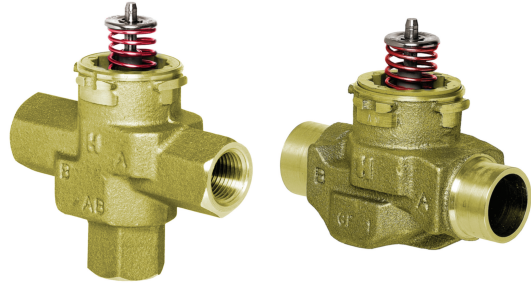

SPECIFICATIONS

The specifications following are nominal and conform to generally accepted industry standards. Honeywell is not responsible for damages resulting from misapplication or misuse of its products or non-workmanlike installation practices.

Operating Ambient:

32 to 150°F [0 to +65°C].
5-95% RH (non-condensing)

Fluid temperatures:

34 to 203°F [1 to 95°C]

Shipping and Storage Temperature:

-40 to 150°F [-40 to +65°C]

Atmosphere:

Non-corrosive, non-explosive.

Valve Materials:

Body of bronze Cartridge of Ryton™ (polyphenylene sulphide) and Noryl™ (polyphenylene oxide)
O-ring seals of EPDM rubber
Stem of stainless steel

Pressure Rating:

Static - 300 psig [20 Bar] maximum.
Burst - 1500 psig [100 Bar]
Operating Differential and Close-off - 60 psi maximum [4 bar]

Stem Travel:

0.4 inches [10 mm]

Flow Characteristics:

Linear or equal percentage, per Table 2.

Spring Force:

1000 and 6000 Series(Silver): 14 lbf.

3000 and 7000 Series(Red): 20 lbf.

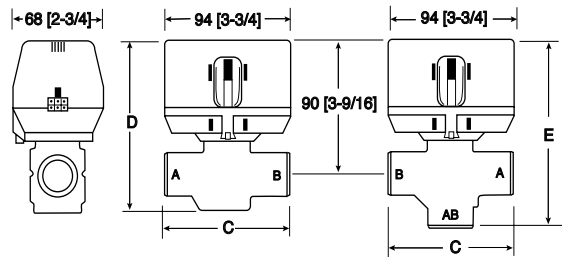

Figure 1 - Nominal dimensions in inches [millimetres]

[1] Pipe Fitting Sizes	Dimension C		Dimension D		Dimension E	
	mm	Inches	mm	Inches	mm	Inches
1/2" SWEAT	89	3-1/2	111	4-3/8	130	5-1/8
1/2" NPT (int.)	98	3-7/8			136	5-11/32
3/4" NPT (int.)					130	5-1/8
3/4" SWEAT					132	5-3/16
1" NPT (int.)	94	3-11/16	113	4-7/16	136	
1" SWEAT						5-11/32
1-1/4" SWEAT						
1-1/4" NPT (int.)	110	4-5/16	118	4-5/8	142	5-5/8

[1] All models not available in all countries

Table 1: VC Valve assembled dimensions

Accessories and Replacement Parts:

40007029-002: Cartridge installation wrench (included with all VCZZ replacement cartridges)

272866B: Valve caps for system flushing (10 per pack)

2-way Replacement Cartridges:

VCZZ1000: quick open

VCZZ1100: high Cv, linear flow

VCZZ3100: high Cv, linear flow

VCZZ3400: medium-high Cv, equal percentage flow

VCZZ3500: low Cv, equal percentage flow

VCZZ3600: medium-low Cv, equal percentage flow

VCZZ3800: medium Cv, equal percentage flow

MODELS:

BODIES: VCA,B,M,N ..., per table: 2

ACTUATORS (ORDER SEPARATELY)

2-way Valve Number	Cartridge Pipe Fitting Sizes [2]	Cartridge						
		1000	1100 [1]	3100	3400	3500	3600	3800 [5]
VCZ AA	1/2" SWEAT	Nominal Cv Rating						
VCZ BB	1/2" NPT (int.)							
VCZ AL	3/4" NPT (int.)	3.5	3.3	3.3	2.3	0.6	1.3	1.9
VCZ AM	3/4" SWEAT	6.2	4.7	4.7	3.9	0.7	1.5	3.2
VCZ AR	1" NPT (int.)	7.0	6.6	6.6	4.2			
VCZ AS	1" SWEAT	8.3	7.0	7.0	Equal Percentage		3.5	
VCZ BE	1-1/4" SWEAT	Quick Open		Linear				
VCZ BD	1-1/4" NPT (int.)	2-position		Proportional Control [4]				
Flow characteristic		Quick Open		Linear		Equal Percentage		
Application		2-position		Proportional Control [4]				

[1] "1200" series cartridge has the same Cv/kV rating as "1100" series.

Suitable for use in potable water situations

[2] Models are country specific. Not all models are available in all markets.

Cv values in greyed-out boxes are listed for reference only:

[3] A port is 5% higher, and B port is 5% lower in mixing configuration. B port is 5% higher, and A port is 5% lower in diverting configuration

3-way Replacement Cartridges:

VCZZ6000: quick open

VCZZ6100: high Cv, linear flow

VCZZ7100: high Cv, linear flow

VCZZ7400: medium-high Cv, linear flow

VCZZ7500: low Cv, linear flow

VCZZ7600: medium-low Cv, linear flow

VCZZ7800: medium Cv, linear flow

3-way Valve Number	Cartridge Pipe Fitting Sizes [2]	Cartridge						
		6000	6100	7100	7400	7500	7600	7800 [5]
VCZ MA	1/2" SWEAT	Nominal Cv Rating [3]						
VCZ NB	1/2" NPT (int.)							
VCZ MK	3/4" NPT (int.)	4.2	3.8	3.8	2.7	0.7	1.3	2.2
VCZ ML	3/4" SWEAT	8.0	6.6	6.6	4.2	0.8	1.5	3.4
VCZ MR	1" NPT (int.)	9.0	7.4	7.4	5.2			
VCZ MS	1" SWEAT	9.9	8.3	8.3	Linear		4.2	
VCZ NE	1-1/4" SWEAT	Quick Open		2-position				
VCZ ND	1-1/4" NPT (int.)	2-position		Proportional Control [4]				
Flow characteristic		Quick Open		Linear		Equal Percentage		
Application		2-position		Proportional Control [4]				

[4] Divide Cv value by 0.4 to obtain rangeability

[5] -800 Cartridge Cv ratings in larger bodies sizes are estimates at time of printing.

[6] O.S. Example: 1/2" 2-way NPT, 3.3Cv, for proportional control is VCZBB body with 3100 cartridge = VCZBB3100.

Table 2: VC Series Valve Bodies

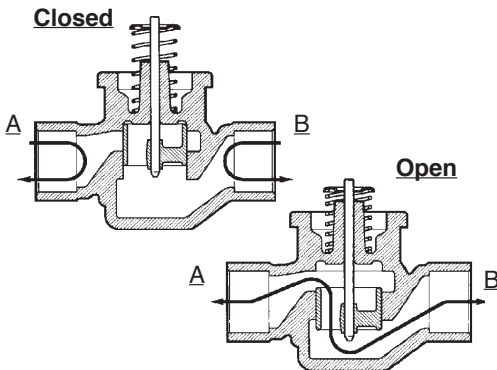

Figure 2 - Fluid flow of 2-way valves

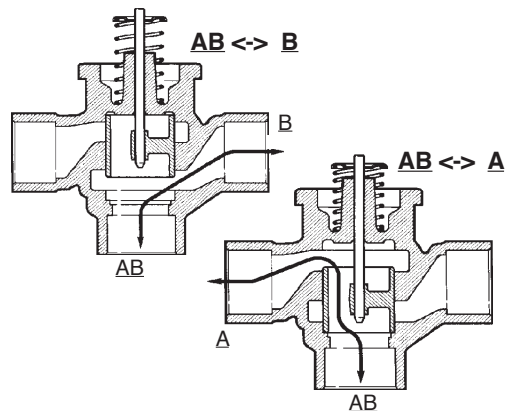

Figure 3 - Fluid flow of 3-way

INSTALLATION

WHEN INSTALLING THIS PRODUCT:

1. Read these instructions carefully. Failure to follow them could damage the product or cause a hazardous condition.
2. Check the ratings given in the instructions and on the product to make sure the product is suitable for your application.
3. **Installer must be a trained and experienced service technician.**
4. Always conduct a thorough check-out when installation is completed.
5. While not necessary to remove the actuator from the body, it can be removed for ease of installation. The actuator can be installed in any of the four orientations to suit the most convenient wiring direction. Actuator latching mechanism works only when the lengths of the actuator and the valve body are parallel to each other.



CAUTION:

Disconnect power supply before connecting wiring to prevent electrical shock and equipment damage.

On 24V systems, **never** jumper the valve coil terminals, even temporarily. This may damage the thermostat.



PROPER USE:

These valves are only for use in cold, warm, and hot water applications. They are designed for a medium temperature range of from 34 to 203°F (1 to 95 C), at a maximum pressure of 300 psig (20 bar). They are to be operated with the appropriate Honeywell actuators only. Water must be properly filtered, treated and conditioned according to local conditions.

The presence of suspended particulate(s) in the system, such as detached calcium scale, sand, silt, large quantities of magnetite, etc., can affect operation of the valve. For trouble-free operation of this product, good installation practice should include initial system flushing, chemical water treatment, and the use of a 50 micron (or finer), 10% system side-stream filter(s). Remove all filters before flushing.

Put the VC actuator manual lever in the fully up position or the half open (down) position to allow initial system flushing with the actuator mounted. This may be done without electrical hook-up. Alternatively, reusable flush caps, part # 272866B, may be purchased separately for use in initial flushing of dirty hydronic systems.

Do not use boiler additives, solder flux and wetted materials which are petroleum based or contain mineral oil, hydrocarbons, or ethylene glycol acetate. Compounds which can be used, with minimum 50% water dilution, are diethylene glycol, ethylene glycol, and propylene glycol (antifreeze solutions).

IMPORTANT:

The presence of iron oxide (red rust) in the system voids the valve warranty.

PLUMBING

The valve may be plumbed in any angle, including vertical piping, but preferably not with the actuator below horizontal level of the body. Make sure there is enough room around the actuator for servicing or replacement.

For use in diverting applications, the valve is installed with the flow water entering through bottom port AB, and diverting through end ports A or B. In mixing applications the valve is installed with inlet to A or B and outlet through AB.

Mount the valve directly in the tube or pipe. Do not grip the actuator while making and tightening up plumbing connections. Either hold valve body in your hand or attach adjustable spanner (38 mm or 1-1/2") across hexagonal or flat faces on the valve body (Figure 4).

If assembling valve train on a bench, take care not to deform body with vice. **Do not place the raised "H" logo between the jaws of the vice.** Excess jaw force can deform the body.

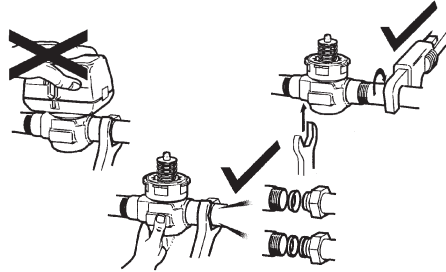

Figure 4 - Plumbing of the VC Valve

COMPRESSION MODELS

For compression fitted models, tighten the compression nuts enough to make a watertight seal. **TAKE CARE NOT TO OVERTIGHTEN.** Maximum torque limit is 33 ft-lb for the 22 mm compression fitting, and 48 ft-lb for the 28 mm compression fitting.

SWEAT MODELS

On sweat fitted valves, the cartridge is shipped loose to avoid being damaged during the solder operation.

1. Remove valve actuator from body and solder the connecting pipes in accordance with normal soldering practices.
2. After soldering and valve has cooled, remove cartridge assembly from plastic bag, insert into the valve body and tighten down with enclosed wrench until it bottoms out. **DO NOT OVERTIGHTEN** (maximum torque is 40 in-lb). See Figure 5.
3. Replace valve actuator.

TO REPLACE CARTRIDGE (IF REQUIRED)

Two-way cartridges fit all two-way bodies. The Cv rating of a valve can be changed by replacing the cartridge, allowing for unique combinations. Three-way cartridges fit all three-way bodies. Cartridges for proportional control applications have high force springs color-coded red.

1. Disconnect power supply before servicing to avoid electrical shock or equipment damage.
2. Depending on the installation, it may be necessary to disconnect leadwires to valve actuator, or depress tab on Molex™ connector and remove. Where appropriate, label wires for rewiring.
3. Remove valve actuator by pressing up on the latch mechanism located directly below the red manual open lever with thumb (See Figure 5). Simultaneously press the actuator down towards the valve body with moderate hand force and turn the actuator counter-clockwise by 1/8 turn (45°). Lift actuator off the valve body.

- To replace a cartridge, **isolate flow to the valve** using installed shut off valves or other service equipment designed for this purpose. Remove old cartridge with 40007029-002 wrench supplied with the replacement unit. It may be necessary to use pliers or other tools to remove the old cartridge due to calcium or dirt buildup in the valve body.
- Clean the valve surfaces marked * and ** in Figure 6 to ensure the new cartridge O-rings seal at these points. Use care to avoid damage to these surfaces (** for 3-way valves only).

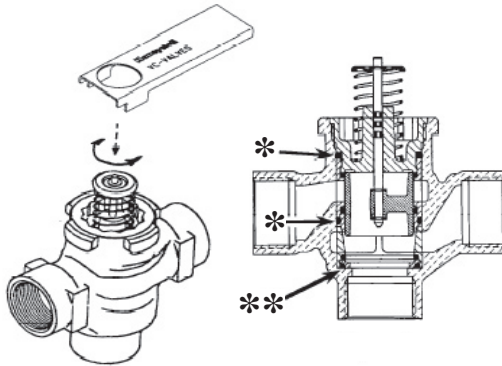

Figure 5 - Installing Cartridge

Figure 6

- Remove the pre-lubricated cartridge assembly from its plastic bag. Thread it by hand into the valve body and tighten it down with the enclosed wrench until it bottoms out. **DO NOT OVER TIGHTEN:** maximum torque is 40 in-lb. [4.5 Nm]. The top surface of the cartridge should be flush with the top edge of the body casting.
- Replace valve actuator by following the procedure in the "To Install Actuator" below.
- Reconnect leadwires or Molex™ connector if necessary.
- Refill hydronic system or restore system flow by opening isolating valves.
- Restore power, and checkout operation of cartridge in valve, making sure of no internal seat leakage or external body leakage.

Restore system pressure slowly to the valve to allow any trapped air to escape. Check for leaks. Re-install the actuator.

TO INSTALL ACTUATOR

NOTE: Installation of a new actuator does not require draining the system, provided the valve body and valve cartridge assembly remain in the pipeline. Wiring may be done either before or after the actuator is installed.

Refer to the VC Actuator Installation and Instruction sheet for detailed wiring and check-out instructions.

- The actuator head is automatically latched to the valve. Align the coupling hole in the bottom of the actuator with the valve stem. Press the actuator down towards the body with moderate hand force and turn the actuator counter-clockwise by 1/8 turn (45 degrees) to line up the actuator with the piping. The lock will click when engaged (See Figure 7).

NOTE: The actuator can also be installed at right angles to the valve body but in this position the lock mechanism will not engage.

- Connect leadwires.
- Restore power and check operations.

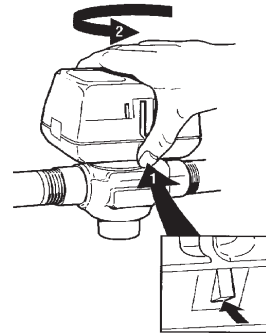

Figure 7 - Lock Mechanism to detach Actuator

SERVICE

This valve should be serviced by a trained, experienced service technician.

- If the valve is leaking, drain system **OR** isolate valve from the system. Do not remove valve body from plumbing.
- Check to see if the cartridge needs to be replaced.
- If the motor or other internal parts of the actuator is damaged, replace the entire actuator assembly.

NOTE: Honeywell VC series hydronic valves are designed and tested for silent operation in properly designed and installed systems. However, water noises may occur as a result of excessive water velocity. Piping noises may also occur in high temperature (over 212°F [100°C]) systems with insufficient water pressure.

Honeywell