

# **Parflex**<sup>®</sup>

**Flexible Gas Piping System**

Design and Installation Guide  
with Training Exam

---

Bulletin No. 4660-PGP2T  
Effective Date September 2006



## Save Time and Money with Parker's *Parflex*® Flexible Gas Piping System

Parker is recognized as the world leader in connector design and manufacturing. By constantly searching for new and innovative ways to make jobs simple, reliable and fast, Parker developed new technology for fuel gas distribution.

The Parflex Flexible Gas Piping System is a complete system certified to ANSI LC-1 standards by CSA International. The Parflex System is simple to install and includes everything needed for gas piping in residential, commercial and light industrial projects.

### The Innovative Parflex System is Simple, Reliable and Fast...

**Simple** Just push in the tubing and tighten the nut, no clumsy disassembly and re-assembly required.

**Reliable** Seals the first time, so you don't waste time chasing leaks and re-testing.

**Fast** Installs 40% faster than old fashioned split-ring and split ferrule designs and up to 75% faster than black iron pipe.

### *Parflex*® Flexible Gas Piping System Approvals, Listings and Compliances

**CSA** - United States & Canada ANSI/IAS LC-1 • CSA 6.26: Certification #: 160705-1134585

**ICC** - International Fuel Gas Code

**BOCA** - National Mechanical Code

**ICBO** - International Conference of Building Officials -File No. ER-5364

**SBCCI** - Standard Gas Code

**IAPMO** - International Association of Plumbing & Mechanical - Officials - File No. C-3651

**CABO** - One and Two Family Dwelling

**NFPA 54** - National Fuel Gas Code

**CGA** - Canada Natural Gas and Propane Installation Code

The *Parflex*® Flexible Gas Piping System is designed and engineered specifically for the transfer of interior fuel gas. Design-certified by ANSI/CSA, the Parflex System must be installed by properly trained personnel. System components are not interchangeable with components from other manufacturers.

# **Parflex<sup>®</sup>**

**Flexible Gas Piping System**

Design and Installation Guide  
with Training Exam

---

Bulletin No. 4660-PGP2T  
Effective Date September 2006



[www.parflexsystem.com](http://www.parflexsystem.com)



# Caution!

This design manual provides basic guidelines to follow in the design and installation of fuel gas piping systems using Parker Parflex™ corrugated stainless steel tubing (CSST). The design, methods, and installation procedures must comply with local building codes. When local codes do not exist, installation must comply with the National Fuel Gas Code, ANSI Z223.1/NFPA 54 (USA) or Installation Codes Canadian CGA B149.1 and B149.2. Please see the entire Parflex System design and installation guide for complete instructions.

Care must be taken to ensure that proper engineering practices and procedures are followed in the design, installation, and testing of the gas piping system. All Parker Parflex corrugated stainless steel tubing systems must be installed by trained and qualified installers. The installation and assembly instructions described in this manual must be followed exactly. Only components specified and sold by Parker as part of the Parflex system are to be used. All installed Parflex systems must be tested and pass inspection by local authority having jurisdiction before being placed into service.

This design and installation guide has been prepared in accordance with:

- The American National Standard, Fuel Gas Piping Systems Using Corrugated Stainless Steel Tubing, ANSI LC1.
- CGA Laboratory Requirement—Flexible Gas Tubing for Natural and Propane Gas Piping Systems, No. LAB-009, CGA 6.26.



## WARNING

FAILURE OR IMPROPER SELECTION OR IMPROPER USE OF THE PRODUCTS AND/OR SYSTEMS DESCRIBED HEREIN OR RELATED ITEMS CAN CAUSE DEATH, PERSONAL INJURY AND PROPERTY DAMAGE.

This document and other information from Parker Hannifin Corporation, its subsidiaries and authorized distributors provide product and/or system options for further investigation by users having technical expertise. It is important that you analyze all aspects of your application and review the information concerning the product or system in the current product catalog. Due to the variety of operating conditions and applications for these products or systems, the user, through its own analysis and testing, is solely responsible for making the final selection of the products and systems and assuring that all performance, safety and warning requirements of the application are met.

The products described herein, including without limitation, product features, specifications, designs, availability and pricing, are subject to change by Parker Hannifin Corporation and its subsidiaries at any time without notice.

## Offer of Sale

The items described in this document are hereby offered for sale by Parker Hannifin Corporation, its subsidiaries or its authorized distributors. This offer and its acceptance are governed by the provisions stated in the "Offer of Sale."

Extra care has been taken in the preparation of this literature, but Parker Hannifin is not responsible for any inadvertent typographical errors or omissions.

## Table of Contents

<b>Section 1.0</b>	<b>Introduction</b>	
1.1	Warnings to User .....	5
1.2	Design Guide Limitations.....	5
1.3	Listing of Standards and Codes .....	5
<b>Section 2.0</b>	<b>System and Components</b>	
2.1	Parflex System Description .....	6
2.2	Parflex System Components .....	7
	Tubing .....	7
	Mechanical Fittings.....	8
	Stub-Outs.....	11
	Protection Devices .....	12
	Regulators and Accessories .....	13
	Manifolds .....	14
	Shut-off Valves.....	15
	Other Components.....	16
<b>Section 3.0</b>	<b>System Configuration and Sizing</b>	
3.1	System Configuration .....	18
3.1.1	System Planning.....	18
	Specific Gravity Factor.....	18
	Sizing and Pressure Loss .....	19
	Series System.....	19
	Parallel System .....	19
3.1.2	Pressure System .....	20
	Low Pressure System.....	20
	Medium Pressure System .....	20
	Dual Pressure System .....	20
	Elevated Pressure System.....	21
3.2	System Sizing Methods and Examples .....	22
3.2.1	Sizing Methods .....	22
	Longest Length Method.....	22
	Elevated / Dual Pressure Method.....	22
	Summation Method .....	22
3.2.2	Longest Length Series System Example (Low Pressure).....	22
3.2.3	Longest Length Parallel System Example (Medium Pressure).....	24
3.2.4	Dual Pressure System Example .....	25
3.2.5	Parallel Elevated System Example.....	26
3.2.6	Parflex System / Steel Pipe Hybrid System Example.....	28
3.2.7	Parallel Medium Pressure System – Summation Method Example.....	30
3.2.8	Propane Elevated Dual Pressure System .....	31
<b>Section 4.0</b>	<b>Installation Practices</b>	
4.1	General Practices .....	32
4.2	Fitting Assembly .....	33

Continued

**Table of Contents**

4.3	Routing.....	36
4.3.1	Vertical Runs .....	36
4.3.2	Horizontal Runs .....	36
4.3.3	Clearance Holes.....	36
4.3.4	Concealed Fittings .....	37
4.3.5	Modifying/Adding to Existing Piping Systems .....	37
4.3.6	Outdoor Routing.....	38
4.3.7	Routing through Fire Walls.....	38
4.4	Protection .....	39
4.4.1	Striker Plates .....	39
4.4.2	Steel Conduit .....	41
4.5	Meter Hook-ups.....	42
4.5.1	Self Supported Meter .....	42
4.5.2	Pipe Supported Meter.....	42
4.6	Connections .....	44
4.6.1	Movable Appliance Connection .....	44
4.6.2	Immovable Appliance Connections.....	44
4.6.3	Specific Applications (Outdoor appliances / Fireplace) .....	44
4.7	Manifold Stations.....	48
4.7.1	Configurations .....	48
4.7.2	Allowable Locations.....	48
4.8	Line pressure Regulators .....	49
4.8.1	Installation requirements.....	49
4.8.2	Venting.....	49
	Vent Limiter .....	49
	Vent Line Sizing Requirements.....	49
4.8.3	Adjustments.....	49
4.8.4	Over-Pressurization Protection.....	50
4.9	Underground Installations.....	50
4.10	Electrical Bonding and Grounding .....	50
 <b>Section 5.0 Inspection, Repair and Replacement</b>		
5.1	Minimum Inspection Requirements.....	51
5.2	Repair of Damaged Tubing.....	52
	5.2.1 Inspection .....	52
	5.2.2 Methods of Repair.....	52
 <b>Section 6.0 Pressure/Leakage Testing</b>		
6.1	Testing Requirements .....	53
6.1.1	Testing Low Pressure Systems.....	53
6.1.2	Testing Elevated Pressure Systems .....	53
6.1.3	Testing Appliance Connections.....	53
 <b>Section 7.0 Sizing and Pressure Drop Tables</b>		
7.1	CSST Tables .....	54
7.2	Steel Pipe Table .....	60

**Section 8.0 Definitions****Offer of Sale**

**Section 1.0 Introduction****1.1 Warnings to User**

The installation of the Parflex Flexible Gas Piping System, Parflex System, must be performed by a qualified installer. The installer must be qualified by all applicable state and/or local authorities having jurisdiction and must have successfully completed the Parflex training program.

**Warning:** Strict adherence to all local building codes as well as this guide during the design, installation, and testing of the piping system must be performed. Improper installations could cause bodily injury or property damage including explosions, fires, or gas asphyxiation.

This guide is to be used in combination with local building codes. Where a discrepancy occurs between this guide and the local building codes the local code shall take precedence.

This manual provides the recommended practices to the professional gas installer in the planning, routing and testing of Parflex Flexible Gas Piping System. The recommended practices contained in this guide apply only to the Parflex System. Use of other CSST systems in conjunction with the Parflex System is prohibited. Standard steel pipe fittings must be used to join existing piping systems from other CSST manufacturers in the cases of addition or repair.

**1.2 Design Guide Limitations**

This guide is written to aid the certified gas tubing installer in the design, assembly, installation and testing of the Parflex System for residential and commercial buildings. This guide does not cover every possible variation in plumbing configurations, construction styles, appliance loads and local restrictions. Applications not covered in this document will require the system designer and installer to seek technical assistance from other sources.

The techniques included in this document are recommended practice for general applications. System design and installation practices must comply with all applicable local fuel gas codes and building codes. **Where conflict exists between the recommended practice and local codes, the local code must take precedence unless a variance is obtained from the local authority having jurisdiction.** This design guide and related components are only to be used for the installation of Parker's Parflex Flexible Gas Piping Systems where operating pressure does not exceed 5 psig. Contact your local fuel gas utility for additional information about gas piping systems.

This document has been prepared in accordance with the latest national and regional codes in effect. Parker cannot assure the installer local code officials will accept these codes. It is the responsibility of the system installer to determine the suitability of using Parflex gas piping and components in construction. **Parker assumes no responsibility for labor or materials which have been installed incorrectly or without prior local code authority approvals.**

**1.3 Listings of Standards and Codes**

**Standards** — The Parflex Flexible Gas Piping System has been tested in accordance with the American National Standard for "Fuel Gas Systems Using Corrugated Stainless Steel Tubing," (ANSI/AGA LC1, CSA 6.26).

**Listings and Codes**

IAS.....	International Approval Services
ICBO .....	International Conference of Building Officials
IAPMO .....	International Association of Plumbing and Mechanical Officials
BOCA .....	Building Officials Code Administrators International
CABO .....	Council of American Building Officials
NFPA 54 .....	National Fuel Gas Code
IFCG .....	International Fuel Gas Code
IMC .....	International Mechanical Code
IPC.....	International Plumbing Code
CSA.....	Canadian Standards Association
ICC.....	International Code Council

## 2.1 Parflex System Description

The Parflex Flexible Gas Piping System, Parflex System, has a number of essential hardware and design differences from conventional gas piping systems using rigid steel (Schedule 40) pipe. These differences can be described as follows:

- a) The system uses corrugated stainless steel tubing (CSST) made of 300 series type material.
- b) The tubing is connected using special patented FastMate™ quick connect mechanical fittings designed specifically for Parker Parflex tubing.
- c) In many applications, the tubing is sized for individual gas appliance loads and is, therefore, usually small in diameter. Parflex can be piped in parallel from a distribution manifold and in series like common steel pipe systems.
- d) The small diameter tubing is suitable for use with elevated pressure systems (above 1/2 psi up to 5 psi).
- e) Different practices are required in the handling and installation of semi-rigid tubing compared to steel pipe.

**The Parflex System may be installed in combination with schedule 40 steel pipe using approved threaded couplings at the interface.** The corrugated stainless tubing can be used for both the low-pressure system (below 1/2 psi) and elevated-pressure system design. It is approved for propane and natural gas applications.

The final piping system design depends on local plumbing restrictions and codes, floor plan, appliance locations, availability of elevated street pressure, total gas load, and system cost. This design manual does not dictate the type of the gas distribution system configuration. The configuration is left up to the system designer. This manual will aid in sizing tubing for the system once the configuration has been selected. The installer should contact the local gas distributor to confirm available service pressures.



**Section 2.0 System Components**

**2.2 Parflex System Components**

**Corrugated Stainless Steel Tubing — (CSST) with polymer jacket. Maximum working pressure 5 psi.**

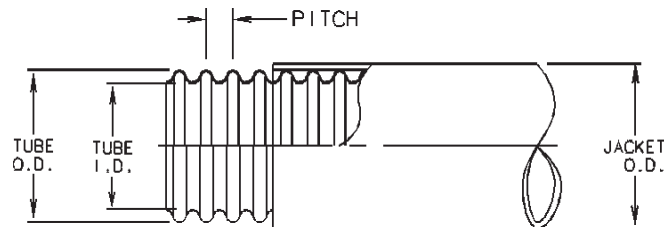

Parameter	Parflex System Part Number				
	PGP-6	PGP-8	PGP-12	PGP-16	PGP-20
Effective Hydraulic Diameter	13	18	23	31	39
Nominal Size	3/8"	1/2"	3/4"	1"	1-1/4"
Inside Diameter (Nominal)	0.39	0.57	0.75	1.04	1.38
Outside Diameter (Nominal)	0.51	0.7	0.93	1.23	1.57
Max. O.D. Over Jacket	0.56	0.75	0.98	1.4	1.63
Pitch (Corrugations per Foot)	76	67	51	49	45
Recommended Min. Bend Radius	3.0	3.0	3.0	5.0	5.0
Length of Reels (Ft.)	50 – 1000	50 – 1000	50 – 1000	50 – 500	50 – 300



**Mechanical Fittings**

**Straight Fitting — Tube to Male Pipe Connector**



**FastMate™ (U.S. Patent No. 6,908,114)  
 Flareless Quick Connect Fittings for Parflex Tubing**

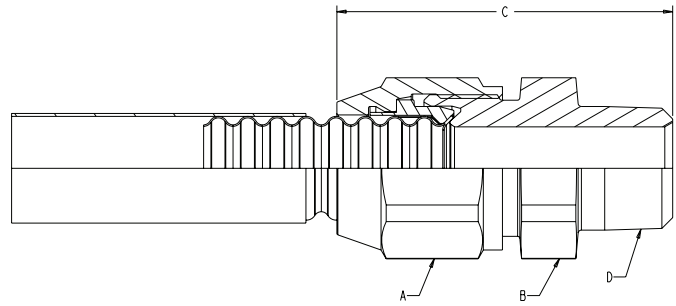

Part No.	Tube Size	Nut Hex [A]	Adapter Hex [B]	Assembled Length [C]	NPTF Thread Size [D]	Weight (lbs.)
2SFM-8-6B	3/8"	7/8	7/8	2.14"	1/2" - 14	0.25
2SFM-8-8B	1/2"	1-1/8	1-1/8	2.26"	1/2" - 14	0.33
2SFM-8-8FB	1/2"	1-1/8	1-1/8	2.26"	1/2" - 14	0.33
2SFM-12-12FB	3/4"	1-7/16	1-3/8	2.48"	3/4" - 14	0.47
2SFM-16-16B	1"	1-3/4	1-5/8	2.67"	1-11-1/2	0.62
2SFM-20-20B	1-1/4"	2-1/4"	2"	3.15"	1-1/4" - 11-1/2	1.5

**Straight Flange Fitting — Tube to Flange Mount Male Pipe Connection**

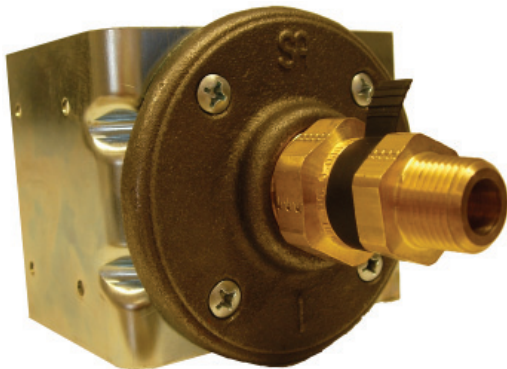

Straight Flange Fitting

\*Shown with optional flange mounting bracket FMB-1.

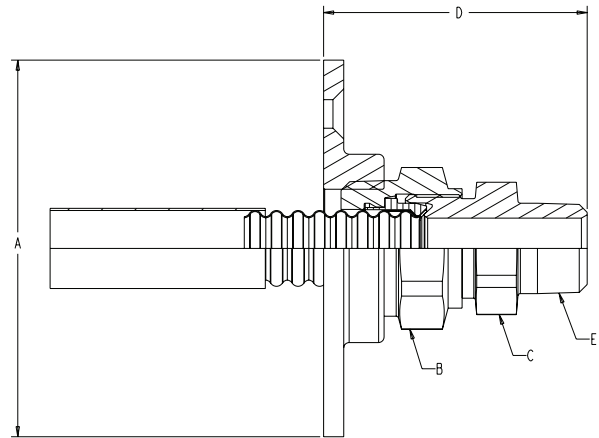

Malleable Iron Part No.	Brass Flange Part No.	Galvanized Flange Part No.	Tube Size	Flange Dia.	Nut Hex	Adapt-er Hex	Assembled Length	NPTF Thread Size	(lbs.)
				A	B	C	D	E	
2FSFM-6B	2BFSFM-6B	2GFSFM-6B	3/8	3-1/2	1-1/8"	7/8"	2.27"	1/2" - 14	.84
2FSFM-8B	2BFSFM-8B	2GFSFM-8B	1/2	4	1-3/8"	1-1/8"	2.42"	1/2" - 14	.96
2FSFM-12B	2BFSFM-12B	2GFSFM-12B	3/4	4	1-5/8"	1-3/8"	2.77"	3/4" - 14	1.35
2FSFM-16B	2BFSFM-16B	2GFSFM-16B	1	4	1-3/4"	1-3/4"	3.23"	1-11-1/2	1.58
2FSFM-20B			1-1/4"	5-1/2	2-1/2"	2"	3-3/4"	1-1/4" - 11-1/2	2.10

**Mechanical Fittings (Continued)**

**Elbow Flange Fitting — Tube to Flange Mount  
90° Elbow Male Pipe Connector**

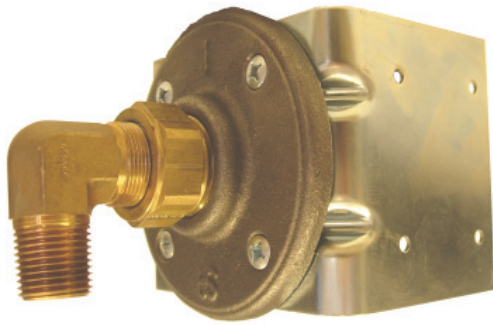

Elbow Flange Fitting

\*Shown with optional flange mounting bracket FMB-1.

**FastMate™** (U.S. Patent No. 6,908,114)

**Flareless Quick Connect Fittings for Parflex Tubing**

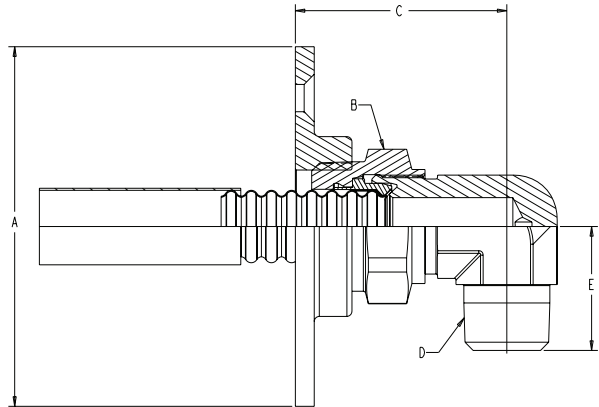

Malleable Iron Part No.	Brass Flange Part No.	Galvanized Flange Part No.	Tube Size	Flange Dia.	Nut Hex	Assembled Length	NPTF Thread Size	Elbow Drop Length	Weight (lbs.)
				A	B	D	E		
2FEFM-6B	2BFEFM-6B	2GFEFM-6B	3/8	3-1/2	1-1/8"	1.89"	1/2" - 14	1.47"	.84
2FEFM-8B	2BFEFM-8B	2GFEFM-8B	1/2	4	1-3/8"	2.07"	1/2" - 14	1.48"	.96
2FEFM-12B	2BFEFM-12B	2GFEFM-12B	3/4	4	1-5/8"	2.56"	3/4" - 14	1.87"	1.35
2FEFM-16B	2BFEFM-16B	2GFEFM-16B	1	4	1-3/4"	3.10"	1-11-1/2	1.97"	1.58

**Tee Fitting — Tube to Tube Tee Fitting**

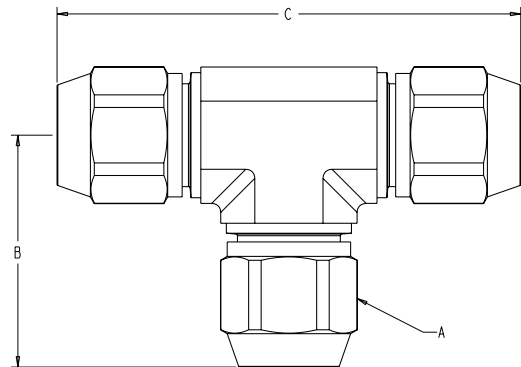

Part No.	Tube Size	Nut Hex	Assembled Length	Tee Drop Length	Weight (lbs.)
		A	B	C	
2TFM-6B	3/8"	7/8"	3.87"	1.94"	.63
2TFM-8B	1/2"	1-1/8"	4.21"	2.11"	1.00
2TFM-12B	3/4"	1-7/16	4.87"	2.44"	1.64
2TFM-16B	1"	1-3/4"	4.81"	2.41"	2.30

Mechanical Fittings (Continued)

**FastMate™** (U.S. Patent No. 6,908,114)  
Flareless Quick Connect Fittings for Parflex Tubing

Transition Brass Tee — Tube to Tube Transition Tee Fitting

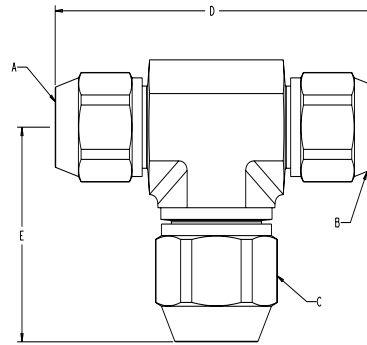

Part No.	Tube Size	Tube Size	Tube Size	Nut Hex	Nut Hex	Nut Hex	Assembled Length	Tee Drop Length	Weight
	A	B	C	A	B	C	D	E	(lbs.)
2TFM-12-8-8B	1/2"	1/2"	3/4"	1-1/8"	1-1/8"	1-7/16"	4.21"	2.44"	1.47
2TFM-16-8-8B	1/2"	1/2"	1"	1-1/8"	1-1/8"	1-3/4"	4.41"	2.41"	1.55
2TFM-12-12-8B	3/4"	3/4"	1/2"	1-7/16"	1-7/16"	1-1/8"	4.87"	2.56"	1.60
2TFM-16-12-8B	1"	3/4"	1/2"	1-3/4"	1-7/16"	1-1/8"	4.66"	2.21"	2.06
2TFM-16-12-12B	1"	3/4"	3/4"	1-3/4"	1-7/16"	1-7/16"	4.66"	2.26"	2.18
2TFM-16-16-8B	1"	1"	1/2"	1-3/4"	1-3/4"	1-1/8"	4.81"	2.21"	2.10

Straight Coupling — Tube to Tube Fitting

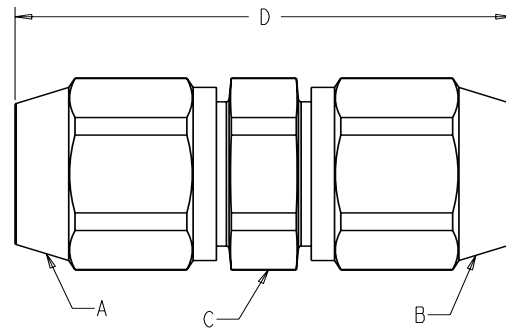

Part No.	Tube Size	Nut Hex	Body Hex	Assembled Length	Weight
	--	A	B	C	(lbs.)
2UFM-6B	3/8"	7/8"	7/8"	2.61"	.27
2UFM-8B	1/2"	1-1/8"	1-1/8"	2.83"	.48
2UFM-12B	3/4"	1-7/16"	1-3/8"	3.19"	.68
2UFM-16B	1"	1-3/4"	1-5/8"	3.23"	.88
2UFM-20B	1-1/4"	2-1/4"	2-1/8"	3.86"	2.10

**Stubouts and Brackets**

**Flange Mount Bracket\***

\*Used for mounting all flange FastMate™ fittings to studs during rough installation. (Kit includes one bracket and fasteners.)

Part No.	A	B	C	Weight (lbs.)
FMB-1	2.9	4	3.5	0.4

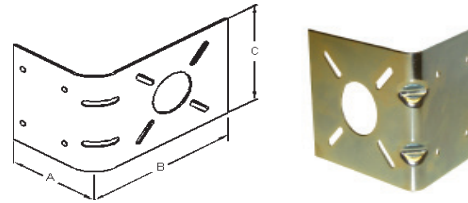

**Stubouts and Bracket — Appliance and Meter Stubs**

**Elbow Stubout**

Part No.	IPS Pipe Size D	A	B	C	Weight (lbs.)
AS01/2	1/2	4.5	2	4.5	1.10
AS03/4	3/4	4.5	2	4.5	1.80
S01X6	1	8	6	5	1.50
S01X10	1	12	10	5	2.00

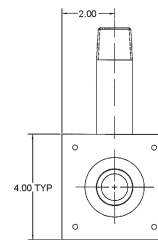
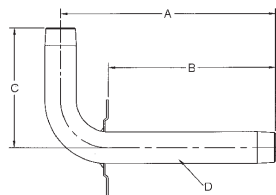

**Straight Stubout**

Part No.	IPS Pipe Size C	A	B	Weight (lbs.)
SS03/4X6	3/4	7.0	1.13	1.25
SS03/4X10	3/4	11	1.13	1.80
SS0125X12	1-1/4	10	4	2.25
SS0125X12	1-1/4	16	4	2.80

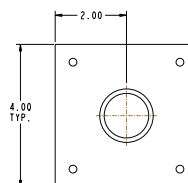
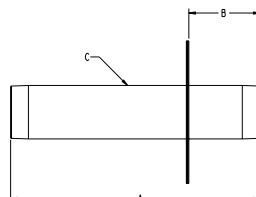

Part No.	Length A	Width B	Depth C	Weight (lbs.)
STB	14.50	5.20	3.25	1.90

**Tubing Protection Components**

**Striker Plates**

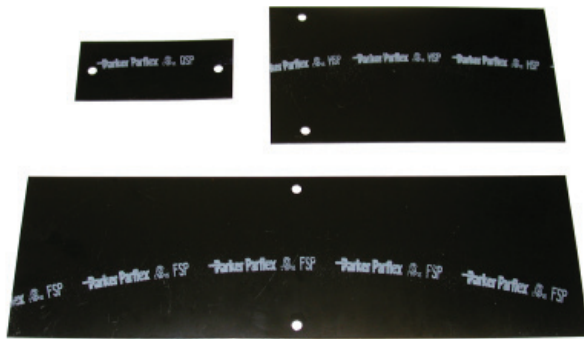

Part No.	Length (in.)	Width (in.)	Weight (lbs.)
QSP	1.5	3.5	0.07
HSP	6.5	3.5	0.31
FSP	11.5	3.5	0.55
PSP	17	7	1.80

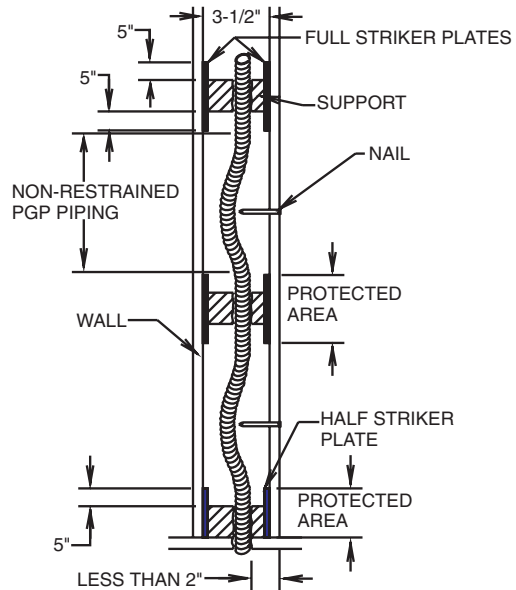

**Flexible Steel Conduit**

For protection of Parflex tubing from puncture at points of support near flange outlets, short tubing runs and where tubing is routed horizontally between studs. Available in bulk length coils and precut 12-inch lengths for all sizes.



Part No.	Nom. ID	Nom. OD	Min Bend Radius (in.)	Weight / 100 ft. (lbs.)	Coil Length (ft.)
PGPSC-6-50FT	0.63	0.77	2-3/4	15	50
PGPSC-8-50FT	.089	1.08	3-1/4	26	50
PGPSC12-25FT	1.19	1.39	3-3/4	45	25
PGPSC-16-25FT	1.51	1.77	4-1/2	62	25
PGPSC-20-25FT					25

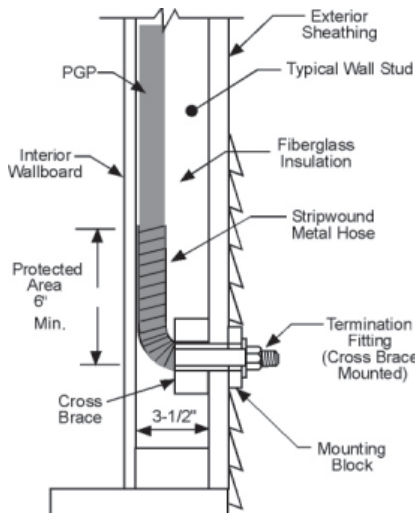

Part No.	Nom. ID	Nom. OD	Min Bend Radius (in.)	Weight / 100 ft. (lbs.)	Coil Length (in.)	Package Qty. (pcs.)
PGPSC-6-12IN	0.63	0.77	2-3/4	15	12	50
PGPSC-8-12IN	.089	1.08	3-1/4	26	20	50
PGPSC-12-12IN	1.19	1.39	3-3/4	45	17	25
PGPSC-16-12IN	1.51	1.77	4-1/2	62	24	25
PGPSC-20-12IN						25



## Appliance Regulators

## Maxitrol 325-3

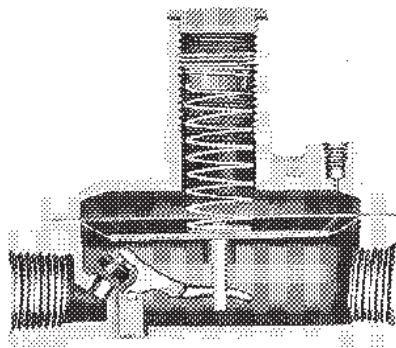
325-3  
(325LP-3)325-5A  
(325LP-5A)

Regulator Part No.	Swing Radius inch (mm)	Female Pipe Size NPT	Vent Port Pipe Size NPT	Factory Set Outlet Pressure inch WC (mbar)	Weight (lbs.)
325-3L	3 (76)	1/2 x 1/2	1/8-27	8 (19)	0.80
325-5A	4-7/8 (124)	3/4 x 3/4	3/8-18	8 (19)	2.02
325LP-3**	3 (76)	1/2 x 1/2	1/8-27	11 (26.6)	0.80
325-5A**	4-7/8 (124)	3/4 x 3/4	3/8-18	11 (26.6)	2.02
325-7	6-1/8 (156)	1-1/4 x 1-1/4	1/2-14	11 (26.6)	3.40

All regulators include automatic vent limiter installed.

13A15 vent protectors are available for outdoor applications without vent limiters.

\*\*Regulators for LP (propane) service are standard 325 series with special spring setting and labeling.

CSA rated pressure ranges: 2 psi (138 mbar), 5 psi (345 mbar).

Maximum inlet pressure: 10 psi.

Over pressure exposure limit: 65 psi

Temperature range limits: -40°F to 205°F (-40°C to 96°C).

## Regulator Flow Capacity

Flow in ft<sup>3</sup>/hr (m<sup>3</sup>/hr) (0.64 Sp.gr. gas)

Regulator Part No.	Pressure Drop Across Regulator: (Inch W.C. or psi)								
	0.3" (0.7mbar)	0.5" (1.2mbar)	1.0" (2.5mbar)	3.0" (7mbar)	5.0" (12mbar)	7.0" (17mbar)	1/2 psi (34mbar)	3/4 psi (52mbar)	1 psi (69mbar)
325-3	30 (0.9)	38 (1.1)	55 (1.6)	95 (2.7)	122 (3.5)	145 (4.1)	204 (5.8)	250 (7.1)	289 (8.2)
325-5A	70 (1.9)	90 (2.5)	128 (3.6)	221 (6.3)	295 (8.1)	338 (9.6)	476 (13.5)	583 (16.5)	673 (19.1)

## Spring Selection Chart for Maxitrol Regulators

Outlet Pressure in Inches W.C. (mbar) or as Noted

Model No.	Standard Spring	CSA Certified			
		2 psi (138 mbar)		5 psi (345 mbar)	
325-3	4 to 12 (10 to 30)	5 TO 9 (12.5 to 22.5)	6 to 10 (17 to 27)	6 to 10 (15 to 25)	7 to 11 (17 to 27)
325-5A	4 to 12 (10 to 30)	5 TO 9 (12.5 to 22.5)	6 to 10 (17 to 27)	6 to 10 (15 to 25)	7 to 11 (17 to 27)

**Distribution Manifolds**

Part No.	A	B	C	D	E	F NPT	Thread NPT	Weight (lbs.)
BM4P-8	9.56"	1.31"	1.31"	2.31"	1.31"	3/4-14 Female	1/2-14 (4 ports)	2.10
4PM-8	11.19"	1.31"	2.13"	2.31"	2.13"	3/4-14 Male	1/2-14 (4 ports)	2.10

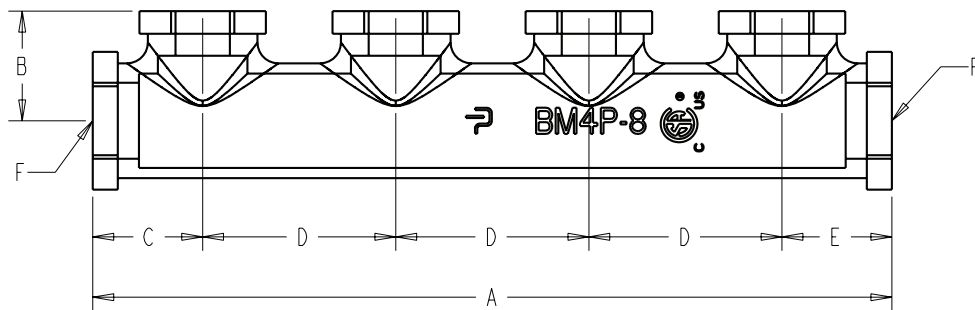

Malleable Iron Manifold  
 (Coated to Prevent Rust)  
 Part No. BM4P-8

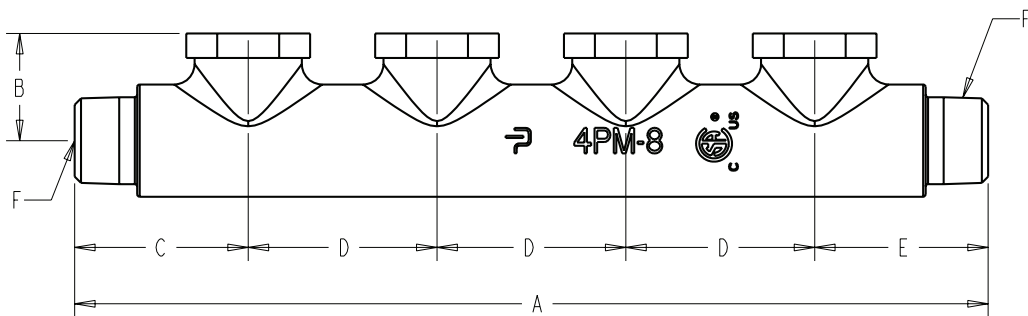

Malleable Iron Manifold  
 (Coated to Prevent Rust)  
 Part No. 4PM-8



Manifold Mounting Bracket  
 Part No. WMB-1

Optional: Manifolds can be made using code approved malleable iron tees and nipples.

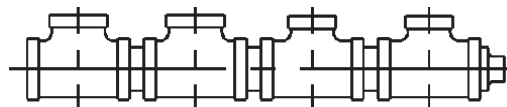

Malleable Iron Tees and Nipples  
 (made with code accepted materials)



**Distribution Manifolds (Continued)**

**Gas Load Center**

1. Metal enclosure with pre-installed mounting bracket.
2. Metallic face plate.

Part No.	Enclosure Panel Dimensions (in.)	Face Ring / Door Dimensions (in.)	Weight
PGLC	W: 14-1/2 H: 18 D: 5-1/4	W: 14-1/2 H: 18	17.25

\*All piping, valve, regulator, union not included.

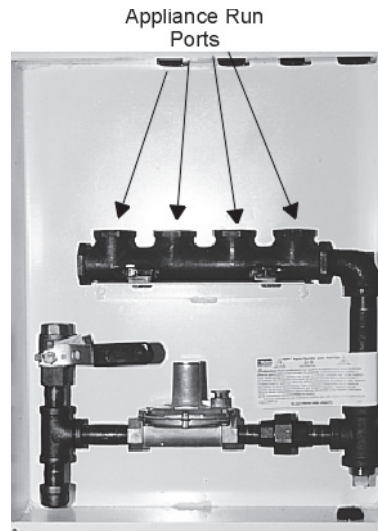

**Shut-Off Valves**

**Lever Handle Ball Valves**

Part No.	Valve Description	Pressure Rating (psi)	Weight (lbs.)
2PGV-1/2	1/2 x 1/2 Straight	2	.5
2PGV-3/4	3/4 x 3/4 Straight	2	.8
5PGV-1/2	1/2 x 1/2 Straight	5	.5
5PGV-3/4	3/4 x 3/4 Straight	5	.8

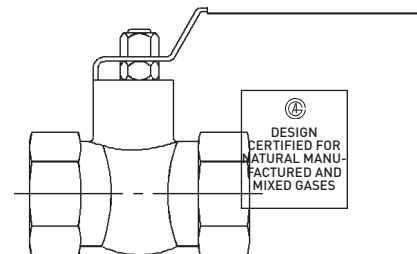

**Ball Valve Flow Capacity  
(0.60 Specific Gravity Natural Gas)**

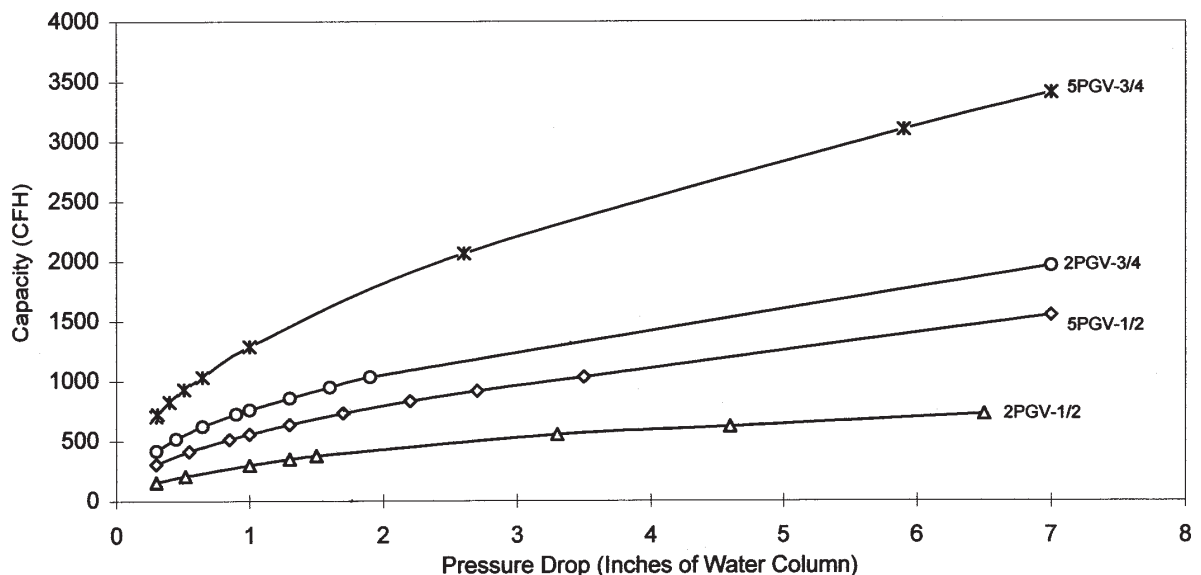

**Shut-Off Valves**

**Indoor / Outdoor Quick Disconnect Valves (Appliance Connectors)**

**Part No. GASOUTLET** — Complete kit includes valve with mounting plate, enclosure and cover housing. (For outdoor appliance installations.)



Design Certified and Listed  
Ref. ANSI Z21.41, Z21.15  
& CAN 1-6-9, 9.1, 9.2, AGA  
Requirement 7-90

**Part No. 103029** — Quick disconnect (3/375) valve for interior appliance installations. Gas connection with 1/2 inch FPT 90° inlet and plug with 3/8 inch FPT outlet.

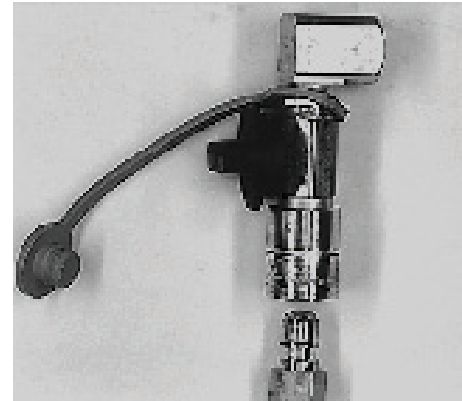

**Assembly Tools**

**Cutters** (U.S. Patent No. 5,907,906)



PGPCT-SM  
PGPCT-LG

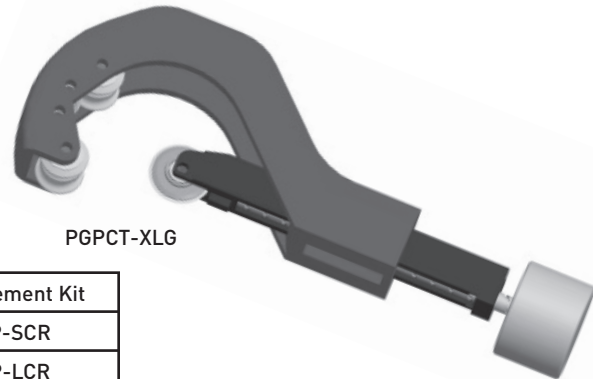

PGPCT-XLG

**Replacement Cutter Wheels and Guides**

Part No.	Tube Size	Wt. (lbs.)	Replacement Kit
PGPCT-SM	3/8", 1/2"	1.05	PGP-SCR
PGPCT-LG	3/4", 1"	1.05	PGP-LCR
PGPCT-XLG	1-1/4", 2"	2.00	PGP-XCR

\*Specially designed polymer rollers for clean cutting of Parker Parflex tubing.

PGP-SCR

PGP-LCR

PGPCT-XL

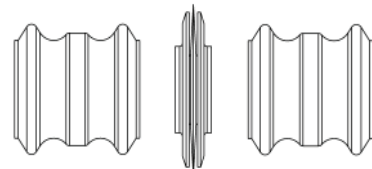
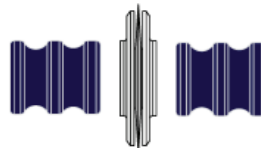
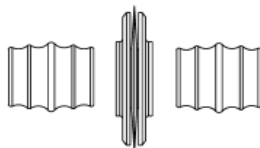



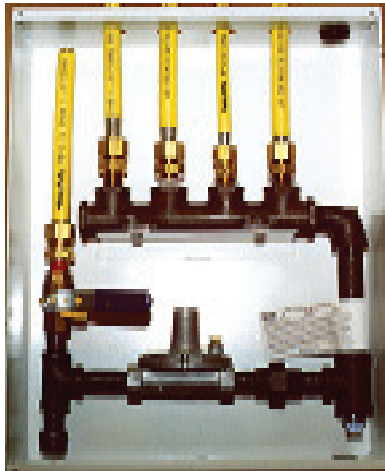

Parflex Warning Tag

After system testing is successfully completed, attach and prominently display the product warning tag or sticker on an interior component of the system (manifold or regulator). This tag must be installed on all completed installations to provide maintenance and repair warnings to the homeowner/resident.



**Parflex™ Flexible Fuel Gas Piping**

 **Warning!** IMPROPER MODIFICATIONS OF THIS PIPE SYSTEM CAN CAUSE DEATH, PERSONAL INJURY, AND PROPERTY DAMAGE. This tag is attached to a special type of flexible fuel gas pipe system which is not compatible with other pipe components. Any and all changes to this pipe system must be made only by a trained and qualified installer using special installation procedures and using only the same brand and type of components. Improper modification or repair of this pipe system can cause a release of gas resulting in asphyxiation, explosion, and fire. SHUT OFF GAS AT SERVICE PANEL OR METER IF PIPING OR CONNECTORS ARE DAMAGED OR LEAKING.

For information about trained installers in your area, please call 1-888-FASTMATE  
**Do not remove this tag.**

1/20/97

3.1 System Configuration

The final piping system design depends on local plumbing restrictions and codes, floor plan, appliance locations, availability of elevated street pressure, total gas load, and system cost. This design manual does not dictate the type of the gas distribution system configuration. The configuration is left up to the system designer. This manual will aid in sizing tubing for the system once the configuration has been selected.

3.1.1 System Planning

Prior to the piping installation, carefully follow the steps provided below

1. Confirm that the local building code authority has accepted the use of the Parflex System. Contact your Parflex System distributor for this information.
2. Check with the local gas utility or supplier to determine the metered gas supply pressure.

**Natural Gas** — Supply pressure in the USA and Canada is typically 6 to 7 inches water column (1/4 psi or 4 ounces). Higher supply pressures 1/2 psi (14 inches WC), 1 psi (28 inches WC), and 2 psi (56 inches WC) will allow reduced tubing size in the Parflex System design plan. The Parflex System can also be used in 5 psi supply pressure systems which are normally restricted to commercial installations.

**Propane (LPG–Liquid Petroleum Gas)** — Typical propane supply pressure for residential buildings is 11 inches water column set at the second stage regulator outside the building. Higher supply pressures will allow reduced tubing size. Check with your propane supplier and local building code authority.

3. Prepare a dimensioned sketch of the installation showing the location of each appliance and possible piping routes.
4. Determine the load (BTU/hr or CFH) demand and the minimum required inlet pressure for each appliance. This data is commonly found on the manufacturer’s nameplate on each gas appliance or is provided by the builder/contractor.
5. Determine the total capacity for all appliances planned in the installation. The BTU equivalents for natural gas or propane flow (CFH) can be obtained from the local gas utility or propane supplier. For natural gas, one cubic foot per hour (1 CFH) is approximately 1,000 BTUH. For propane, one cubic foot per hour (1 CFH) is approximately 2,500 BTUH. The capacity tables in this guide can be used for sizing to meet appliance BTU input loads.
6. Determine the type of piping layout which best fits the installation.

**Specific Gravity Factor** — Systems that are to be supplied with a gas of a specific gravity other than 0.60 for natural gas or 1.52 for propane shall apply a specific gravity factor. This conversion is accomplished by multiplying the flow capacities given in Tables 1 through 13 and on the pressure drop graph by the appropriate multiplier shown in the table below. If the exact specific gravity is not shown in the table, use the next higher specific gravity shown.

Specific Gravity	Conversion Multiplier	Specific Gravity	Conversion Multiplier
0.35	1.31	1.00	0.78
0.40	1.23	1.10	0.74
0.45	1.16	1.20	0.71
0.50	1.10	1.30	0.68
0.55	1.04	1.40	0.66
0.60	1.00	1.50	0.63
0.65	0.96	1.60	0.61
0.70	0.93	1.70	0.59
0.75	0.90	1.80	0.58
0.80	0.87	1.90	0.56
0.85	0.84	2.00	0.55
0.90	0.82	2.10	0.54

**Sizing and Pressure Loss** — The design of a gas system under maximum probable flow conditions must provide gas volume and pressure from the meter to the appliance must be delivered greater than the minimum volume and pressure required for proper equipment operation.

**Series System** — Series system layouts are common in low-pressure, rigid steel piping systems. Numerous elbow and tee fittings are used to branch off of a main run. Generally, a series layout requires larger tubing sizes and more fittings compared with a parallel layout.

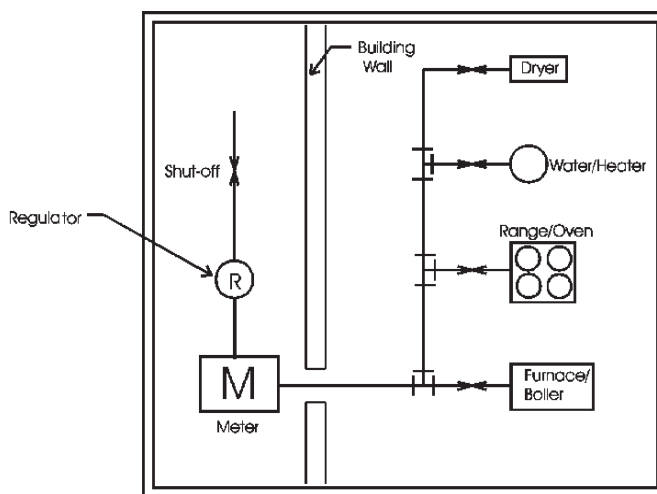

Series System Layout

**Parallel System** — Parallel system layouts utilize a central distribution manifold from which appliances are supplied by branch runs. The manifold is often located closest to the appliance with the highest load; typically, the furnace or boiler. A parallel layout is commonly used in elevated supply pressure systems (above 7 inches WC, 1/4 psi). Generally, a parallel layout requires a higher total footage of smaller diameter tubing and fewer fittings compared with a series layout.

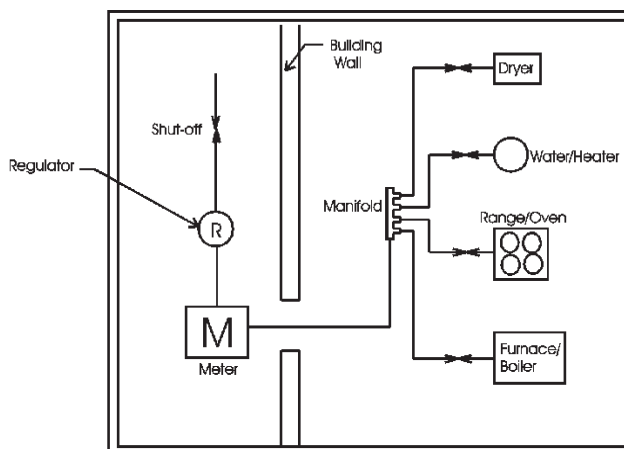

Parallel System Layout

3.1.2 Pressure System

**Low Pressure System** — Low pressure systems have gas service pressure downstream of the meter at less than 1/2 psi (14 inches WC). These systems typically have 7 inches WC (1/4 psi) system pressure for natural gas and 11 inches WC for propane. The allowable pressure drop along any piping run may be specified by local codes. The minimum pressure supplied to each appliance should be considered. Typically, natural gas appliances require 4 inches WC, and propane (LPG) appliances require 10" WC minimum supply pressure measured at the appliance. The second stage regulator for propane systems is often set at 11 inches WC and a 1/2 inch WC maximum pressure drop is allowed through each line. A low-pressure series arrangement typically requires larger diameter tubing to meet appliance demands.

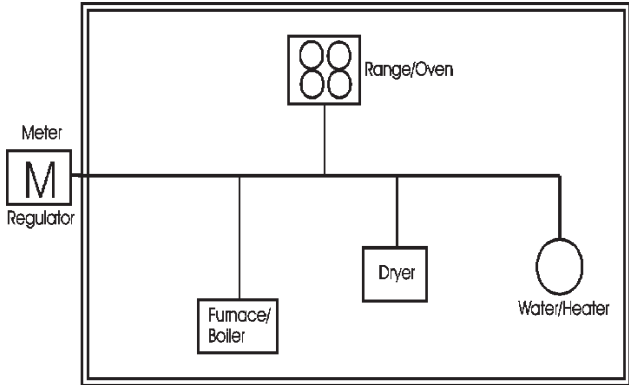

Low Pressure Natural Gas or Propane System (Series)

**Medium Pressure System** — Medium pressure systems have natural gas and propane pressure downstream of the meter or second stage regulator at less than 2 psi. These systems, commonly called 1/2 pound service, have the regulator set at 13 to 14 inches WC. The maximum allowable pressure drop for these systems is based on the difference between the regulator output pressure setting and the appliance inlet pressure requirement.

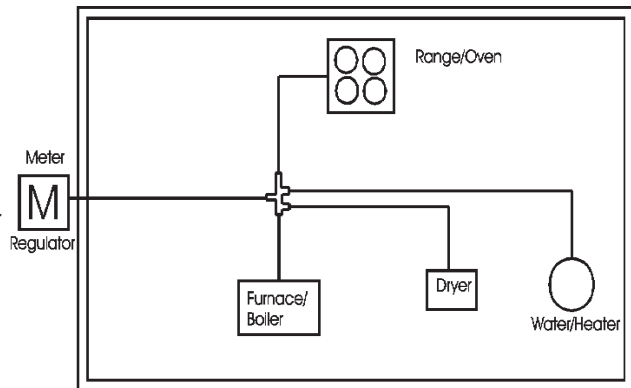

Medium Pressure Natural Gas or Propane System (Parallel)

**Dual Pressure System** — The dual pressure system incorporates two pressure regulators downstream of the meter. The primary pressure set by the service regulator at the meter is normally 2 psi but can be higher or lower based on local code and gas company policy. The secondary pressure, set by the pounds-to-inches regulator, is less than 1/2 psi (normally 8 inches WC) which allows a 3 inch WC drop to each appliance. In system designs where large appliance loads exist, the secondary system should be as short as possible and the pounds-to-inches regulator and manifold should be in close proximity to the appliance with the largest load.

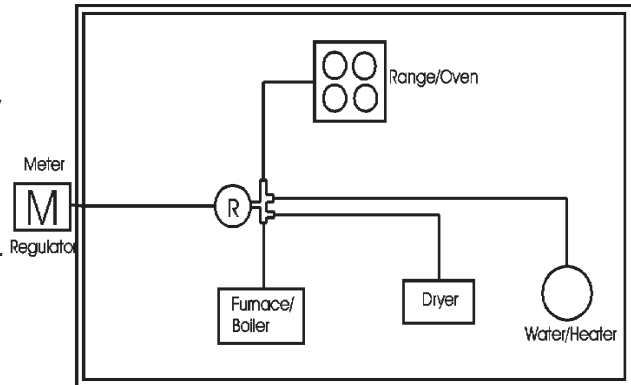

Dual Pressure Natural Gas or Propane System

**Section 3.0 System Configuration & Sizing**

**Elevated Pressure System** — Elevated pressure system layouts use CSST to deliver gas directly to an appliance regulator located directly upstream of the appliance. These systems typically have long runs and high loads.

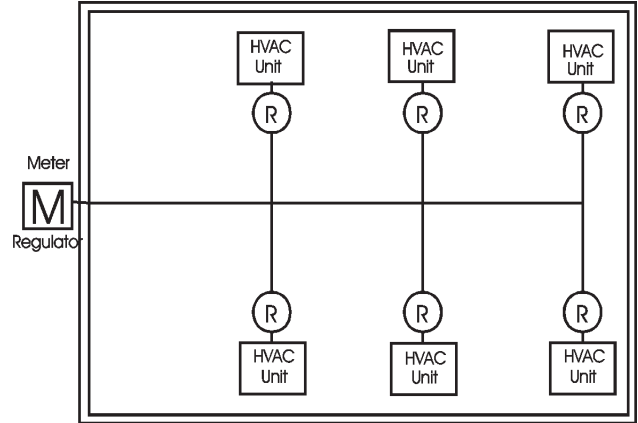

3.2 System Sizing Methods and Examples

3.2.1 Sizing Methods

**Longest Length Method** – The method to size gas piping that take into count the pressure at the down stream end of the meter and the furthest appliance. The piping in the system should be sized large enough to accommodate the entire system load.

**Dual Pressure Method** – The pressure down stream of the primary regulator is elevated most commonly to 2 psig or 5psig. A secondary regulator is located before the manifold.

**Elevated Pressure Method** – Higher pressure is run through a system to each appliance. In this method, a regulator will be placed in front of each appliance.

**Summation Method** – The summation method is used for gas pipe sizing, the pressure losses through the pipe should be considered as to allow minimum pressure and volume of gas to the appliance. Sizing can be accomplished by calculations based on summation of line pressure drops and exact appliance loads. The pressure drop summation method is more precise than the longest length method and may permit the use of smaller diameter tubing in some installations. Pressures should be sufficient to manufacturer’s input rating and the local authority.

3.2.2 Longest Length Series System Example (Low Pressure)

This is a low pressure series system with four natural gas appliances. The utility company supply pressure exiting the meter is 6 inches water column, and the minimum continuous inlet pressure required by the appliances is 5 1/2 inches water column. The maximum allowable pressure drop across the longest length from the meter to the farthest appliance is 1/2 inch water column. The gas supplied has a specific gravity of .60 and an energy content of 1 cubic foot per hour equals 1,000 BTU per hour. Reference Sizing Table 1, Section 7.1, for sizing charts.

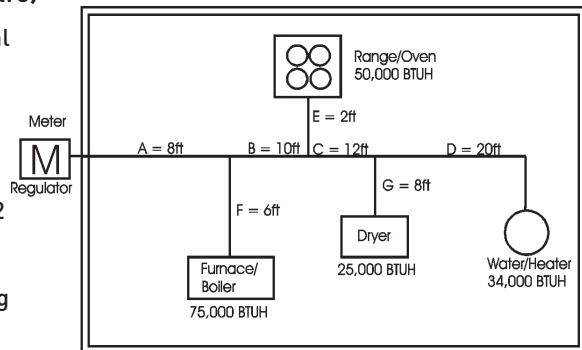

Low Pressure Natural Gas or Propane System (Series)

- Determine the total gas load for each appliance in cubic feet per hour:
 

Furnace.....	75 CFH (75,000 BTUH/1000 BTUH per CFH)
Oven/range .....	50 CFH (50,000 BTUH/1000 BTUH per CFH)
Dryer.....	25 CFH (25,000 BTUH/1000 BTUH per CFH)
Water heater.....	34 CFH (34,000 BTUH/1000 BTUH per CFH)
Total.....	184 CFH
- Measure the length of each run and determine the maximum length from the meter to the farthest appliance.
 

A = 8 ft., B = 10 ft., C = 12 ft., D = 20 ft., E = 2 ft., F = 6 ft. G = 8 ft.

Furnace = A + F = 8 ft. + 6 ft. = 14 ft.

Oven/range = A + B + E = 8 ft. + 10 ft. + 2 ft. = 20 ft.

Dryer = A + B + C + G = 8 ft. + 10 ft. + 12 ft. + 8 ft. = 38 ft.

Water heater = A + B + C + D = 8 ft. + 10 ft. + 12 ft. + 20 ft. = 50 ft.

**The longest run is from the meter to the water heater over 15 ft.**
- Sizing Section A—Length A must be sized to handle the total load of all appliances and the total pressure drop from the meter to the farthest appliance. The total appliance load is 184 CFH. Using the longest length sizing method, the length is 50 ft. to the water heater. Referring to Table 1 (0.5 psig or less; pressure drop 0.5 in. WC) under the 50 ft. length column, we find that 1 inch size (PGP-16) has a flow capacity exceeding 184 CFH (186 CFH). Use 1 inch tubing (PGP-16) to run Section A.
- Sizing Section B—Section B must supply the water heater, dryer, and range. The total pressure drop for the system is considered to be from the meter to the water heater (farthest appliance). The total appliance load is 34 + 25 + 50 = 109 CFH. Using the longest length sizing method, the length is 50 ft. (distance from meter to water heater). Referring to Table 1 under the 50 ft. length column, we find that size 1 inch (PGP-16) has flow capacity over 109 CFH (186). Use 1 inch (PGP-16) to run Section B.



**3.2.2 Longest Length Series System Example (Low Pressure) *Continued***

5. Sizing Section C—Section C must supply the water heater and dryer. The total appliance load is  $34 + 25 = 59$  CFH. Using the longest length method, the length is 50 ft. Referring to Table 1 under the 50 ft. length column, we find that 3/4 inch (PGP-12) has flow capacity above 59 CFH (75). Use 3/4 inch (PGP-12) to run Section C.
6. Sizing Section D—Section D must supply the water heater. The total appliance load is 34 CFH. Using the longest length method, the length is 50 ft. Referring to Table 1 under the 50 ft. length column, we find that 1/2 inch (PGP-8) has flow capacity above 34 CFH (42). Use 1/2 inch (PGP-8) to run Section D.
7. Sizing Section E—The total appliance load is 50 CFH. Using the longest length method, the length from the range/oven is 20 ft. ( $A = 8$  ft. +  $B = 10$  ft. +  $E = 2$  ft.). From Table 1 under the 20 ft. length column, we find that 1/2 inch (PGP-8) has flow capacity above 50 CFH (64). Use 1/2 inch (PGP-8) to run Section E.
8. Sizing Section F—The total appliance load is 75 CFH. The length is 14 ft. ( $A = 8$  ft. +  $F = 6$  ft.). Because there is no 14 ft. column, use the next longer length column. From Table 1 under the 15 ft. length column, we find that 3/4" (PGP-12) has flow capacity of 134 CFH. Use 3/4" (PGP-12) to run Section F.
9. Sizing Section G—The total appliance load is 25 CFH. The length is 38 ft. ( $A = 8$  ft. +  $B = 10$  ft. +  $C = 12$  ft. +  $G = 8$  ft.). Because there is no 38 ft. column, use the next longer length column. From Table 1 under the 40 ft. column, we find that 1/2 inch (PGP-8) has flow capacity above 25 CFH (47). Use 1/2" (PGP-8) to run Section G.

3.2.3 Longest Length Parallel System Example (Medium Pressure)

This is a medium pressure parallel system which includes a distribution manifold. The specific gravity of the gas is 0.60. The allowable pressure drop across the system has been determined to be 7 inches WC (supply pressure 12 inches WC – appliance requirement 5 inches WC). Because there is no 7 inches WC pressure drop chart available we must use the next lowest chart: in this case the 6 inches WC pressure drop chart (Table 8, Section 7.1)

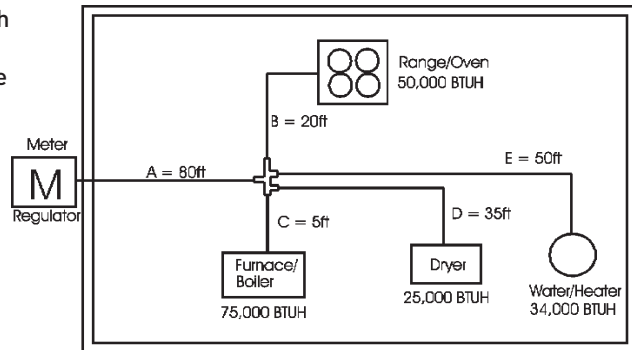

Parallel System

Appliance Loads	Lengths	Tube Size
-	A = 80 ft.	PGP-16 (1")
Oven/Range = 50 CFH	B = 20 ft.	PGP-8 (1/2")
Furnace = 75 CFH	C = 5 ft.	PGP-8 (1/2")
Dryer = 25 CFH	D = 35 ft.	PGP-6 (3/8")
Water heater = 34 CFH	E = 50 ft.	PGP-8 (1/2")
Total 184 CFH		

1. Sizing Section A – Determine distance from meter to the farthest appliance (water heater 130 ft.) Determine the total appliance load supplied by Section A (184 CFH). Since 130 ft. does not appear in the length column, use the next longest length column of 150 ft. Refer to Table 8 under the 150 ft. length column. We find that 1 inch (PGP-16) has flow capacity above 184 CFH (378). Use 1 inch (PGP-16) to run Section A.
2. Sizing Section B – Section B supplies the range/oven. The total pressure drop is considered from the meter to the oven/range. The total load is 50 CFH and the length is 80 ft. + 20 ft. = 100 ft. Referring to Table 8 under the 100 ft. length column, we find that 1/2 inch (PGP-8) has capacity above 50 CFH (98). Use 1/2 inch (PGP-16) to run Section B.
3. Sizing Section C – Section C supplies the furnace. The total load is 75 CFH and the total length is 80 ft. + 5 ft. = 85 ft. Refer to Table 8 under the 85 ft. column. Since 85 ft. does not appear in the length column, use the next longest length column of 90 ft. We find that 1/2 inch (PGP-8) has capacity above 75 CFH (103). Use 1/2 inch (PGP-8) to run Section C.
4. Sizing Section D – Section D supplies the dryer. The total load is 25 CFH and the total length is 80 ft. + 35 ft. = 115 ft. Refer to Table 8 under the 115 ft. column. Since 115 ft. does not appear in the table, use the next longest length column of 125 ft. We find that 3/8 inch (PGP-6) has capacity above 25 CFH (33). Use 3/8 inch (PGP-6) to run Section D.
5. Sizing Section E – Section E supplies the dryer. The total load is 34 CFH and the total length is 80 ft. + 50 ft. = 130 ft. Referring to Table 8 under the 150 ft. column, we find that 1/2 inch (PGP-8) has capacity above 34 CFH (80). Use 1/2 inch (PGP-8) to run Section E.

## 3.2.4 Elevated Dual Pressure Systems

In dual pressure systems, the piping from the meter through the pressure reducing regulator is sized independently of the piping downstream of the pressure reducing regulator. The tables shown in this section are used to size specific pressure systems for natural gas.

**Elevated Dual Pressure Systems Example 1**

This is a 2 psig supply pressure parallel arrangement. The natural gas system incorporates a pressure reducing regulator with a distribution manifold located closely to several large capacity appliances. The inlet pressure downstream of the meter is 2 psig, and the designated maximum pressure drop from the meter to the reducing regulator is 1.0 psig. Use Table 9, Section 7.1. The outlet pressure from the regulator is set at 8 inches of water column. A 3 inch WC pressure drop is used in sizing the tubing from the regulator outlet to each appliance (supply pressure of 8 inches WC – appliance requirement of 5 inches WC). Use Table 5, Section 7.1. Specific gravity of the gas delivered is .60 and energy content is 1 CFH = 1,000 BTU.

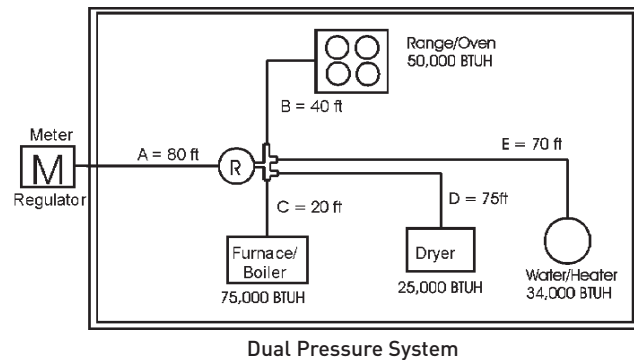

Appliance Loads	Lengths	Tube Size
-	A = 80 ft.	PGP-8 (1/2")
Oven/Range = 50 CFH	B = 40 ft.	PGP-8 (1/2")
Furnace = 75 CFH	C = 20 ft.	PGP-8 (1/2")
Dryer = 25 CFH	D = 75 ft.	PGP-8 (1/2")
Water heater = 34 CFH	E = 70 ft.	PGP-8 (1/2")
Total 184 CFH		

1. **Total Load and Regulator Size** – Calculate the total appliance load and determine if one regulator has sufficient capacity to supply this load. One regulator is normally adequate when appliances are close together. When groups of high-load appliances are widely separated, it is often more economical to use one pressure reducing regulator to supply each appliance group. The total appliance load required is 184 CFH (184,000 BTUH). The supply pressure from the meter is 2 psig and the designated pressure drop from the meter to the regulator is 1psig; therefore, the minimum inlet pressure to the regulator is 1 psig. Since the outlet pressure of the regulator is set at 8 inches WC, the expected pressure drop across the regulator is 20 inches WC (1 psig – 8 inches WC = 20 inches WC). From the regulator pressure drop graph at the end of this section, we find that at a 20 inch WC pressure drop, a single 325-3L regulator has a flow rate capacity is insufficient, a larger 325-5A regulator or a parallel arrangement of two regulators should be used.
2. **Sizing Section A (Meter to Regulator)** – Section A must be sized to handle all appliance loads and supply the pressure reducing (pounds to inches) regulator. The total load is 184 CFH and the length is 80 ft. The supply pressure is 2 psig and the pressure drop is 1 psig. Referring to Table 9 (meter to regulator with 2 psig inlet and 1 psig drop) under the 80 ft. column, we find that size 1/2 inch (PGP-8) has capacity over 184 CFH (210). Use 1/2 inch (PGP-8) to run Section A. To size the other sections, the pressure source is the outlet of the pressure regulator rather than the meter. Use the low-pressure Table 5 (1/2 psi or less; Pressure Drop: 3.0 inches WC) and size each section individually using the appliance load and run distance.
3. **Sizing Section B** – Section B supplies the range/oven. The load is 50 CFH and the distance between the regulator outlet and appliance is 40 ft. The total pressure drop is from the outlet of the reducing regulator to the range/oven. The outlet pressure from the regulator is 8 inches WC (factory set) and the pressure drop is 3 inches WC. Referring to Table 5 under the 40 ft. length column, we find that size 1/2 inch (pgp-8) has capacity above 50 CFH (110). Use 1/2 inch to run Section B.
4. **Sizing Section C** – Section C supplies the furnace. The load is 75 CFH and the distance is 20 ft. Referring to Table 5 under the 20ft. length column, we find that size 1/2 inch (PGP-8) has capacity above 75 CFH (155). Use 1/2 Inch (PGP-8) to run Section C.
5. **Sizing Section D** – Section D supplies the dryer. The load is 25 CFH and the distance is 75 ft. Referring to Table 5, there is no 75 ft. column. We then look under the next column. Under the 80 ft. column, we find that size 3/8 inch (PGP-6) has capacity above 25 CFH (31). Use 3/8 Inch (PGP-6) to run Section D.
6. **Sizing Section E** – Section E supplies the water heater. The load is 34 CFH and the distance is 70 ft. Referring to Table 5 under the 70 ft. length column, we find that size 1/2 inch (PGP-8) has capacity above 34 CFH (84). Use 1/2 Inch (PGP-8) to run Section E.

3.2.5 Parallel Elevated System Example

Elevated Parallel

This example shows a rooftop application to six HVAC Units. Each unit requires 225,000 BTUH Natural Gas.

In this example, we are supplied with 5 psig and the gas company has stated the specific gravity of the natural gas is 0.60. Local codes require a pressure drop of 3.5 psig.

The HVAC Units have been spaced so they are equal in distance.

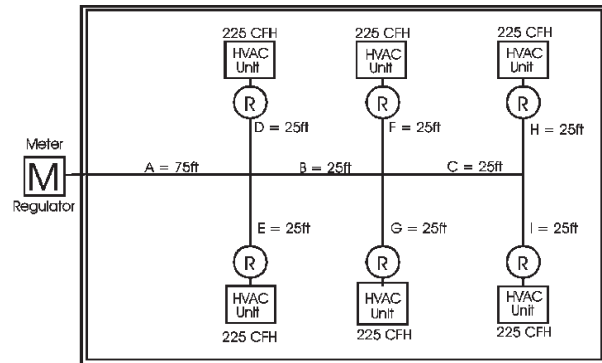

Parallel Elevated System

1. Determine the total gas load for each appliance in cubic feet per hour:
2. Measure the length of each run and determine the maximum length from the meter to the farthest appliance.  
A = 75 ft., B = 25 ft., C = 25 ft., D = 25 ft., E = 25 ft., F = 25 ft. G = 25ft. H = 25ft. I = 25ft.

Farthest Unit = A + B + C + H = 75 ft. + 25 ft. + 25 ft. + 25 ft. = 150 ft.

The longest run is from the meter to the last HVAC Unit at 150 ft.

3. Sizing Section A – Length A must be sized to handle the total load of all appliances and the total pressure drop from the meter to the farthest appliance. The total appliance load is 1,350 CFH. Using the longest length sizing method, the length is 150 ft. to the last HVAC Unit. Referring to Table 11 (5.0 psig; Pressure Drop: 3.5 psig) under the 150 ft. length column, we find that 1 inch Parflex tubing (PGP-16) has a flow capacity exceeding 1,350 CFH (1,539 CFH). Use 1 inch Parflex tubing (PGP-16) to run Section A.
4. Sizing Section B – Section B must supply four HVAC Units. The total pressure drop for the system is considered to be from the meter to the last HVAC Unit. The total appliance load is 225 + 225 + 225 + 225 = 900 CFH. Using the longest length sizing method, the length is 150 ft. Referring to Table 11 under the 150 ft. length column, we find that size 1 inch Parflex tubing (PGP-16) has flow capacity over 900 CFH (1,539 CFH). Use 1 inch Parflex tubing (PGP-16) to run Section B.
5. Sizing Section C – Section C must supply the final two HVAC Units. The total appliance load is 225 + 225 = 450 CFH. Using the longest length method, the length is 150 ft. Referring to Table 11 under the 150 ft. length column, we find that 3/4 tubing (PGP-12) has flow capacity above 450 CFH (570). Use 3/4 Parflex tubing (PGP-12) to run Section C.
6. Sizing Section D – Section D supplies the first HVAC Unit. The total load is 225 CFH and the total length is 25 ft. + 75 ft. = 100 ft. Refer to Table 11 under the 100 ft. column. We find that 1/2 inch (PGP-8) has capacity of 225 CFH (363). Use 1/2 inch (PGP-8) to run Section D.
7. Sizing Section E – Section E supplies the second HVAC Unit. The total load is 225 CFH and the total length is 25 ft. + 75 ft. = 100 ft. Refer to Table 11 under the 100 ft. column. We find that 1/2 inch (PGP-8) has capacity of 225 CFH (363). Use 1/2 inch (PGP-8) to run Section E.
8. Sizing Section F – Section F supplies the third HVAC Unit. The total load is 225 CFH and the total length is 75 ft. + 25 ft. + 25 ft. = 125 ft. Referring to Table 11 under the 125 ft. column, we find that 1/2 inch (PGP-8) has capacity above 225CFH (326). Use 1/2 inch (PGP-8) to run Section F.

Appliance Loads	Lengths	Tube Size
-	A = 75 ft.	PGP-16 (1")
	B = 25 ft.	PGP-16 (1")
	C = 25 ft.	PGP-12 (3/4")
HVAC Unit (225 CFH)	D = 25 ft.	PGP-12 (3/4")
HVAC Unit (225 CFH)	E = 25 ft.	PGP-8 (1/2")
HVAC Unit (225 CFH)	F = 25 ft.	PGP-8 (1/2")
HVAC Unit (225 CFH)	G = 25 ft.	PGP-8 (1/2")
HVAC Unit (225 CFH)	H = 25 ft.	PGP-8 (1/2")
HVAC Unit (225 CFH)	I = 25 ft.	PGP-8 (1/2")
Total 1,350 CFH		

**3.2.5 Parallel Elevated System Example - Continued**

9. Sizing Section G – Section G supplies the Fourth HVAC Unit. The total load is 225 CFH and the total length is 75 ft. + 25 ft. + 25 ft. = 125 ft. Referring to Table 11 under the 125 ft. column, we find that 1/2 inch (PGP-8) has capacity above 225CFH (326). Use 1/2 inch (PGP-8) to run Section F.
10. Sizing Section H – Section H supplies the fifth HVAC Unit. The total load is 225 CFH and the total length is 75ft. + 25 ft. + 25 ft. + 25ft. = 150 ft. Referring to Table 11 under the 150 ft. column, we find that 1/2 inch (PGP-8) has capacity above 225 CFH (299). Use 1/2 inch (PGP-8) to run Section H.
11. Sizing Section I – Section I supplies the last HVAC Unit. The total load is 225 CFH and the total length is 75 ft. + 25 ft. + 25 ft. + 25 ft. = 150 ft. Referring to Table 11 under the 150 ft. column, we find that 1/2 inch (PGP-8) has capacity above 225 CFH (299). Use 1/2 inch (PGP-8) to run Section H.

**Section 3.0 System Configuration & Sizing**

**3.2.6 Parflex System / Steel Pipe Hybrid System Example**

**Hybrid System** — Hybrid system layouts use a combination of CSST and rigid pipe on low or medium pressure systems. These systems typically have long runs and high loads. The rigid pipe is used on long straight runs and the CSST is used to connect to the units.

In this example, we are supplied with 7 inches WC and the gas company has stated the specific gravity of the natural gas is 0.60. Local codes require a pressure drop of 0.5 in. WC.

**Hybrid System Example 1**

This is a low-pressure series system with four natural gas appliances. The main trunk line in this system is specified as black iron and the branches are determined to be Parflex tubing. The utility company supply pressure exiting the meter is 7 inches water column. The maximum allowable pressure drop across the longest length from the meter to the farthest appliance is 1/2 inch water column. Because we are using both black iron pipe and the Parflex tubing, we need to two types of pressure tables. We will use Steel Tables (Table 20, Section 7.1) and Parflex Table of 0.5 psig or less with a pressure drop of 0.5 in. WC (Table 1, Section 7.1).

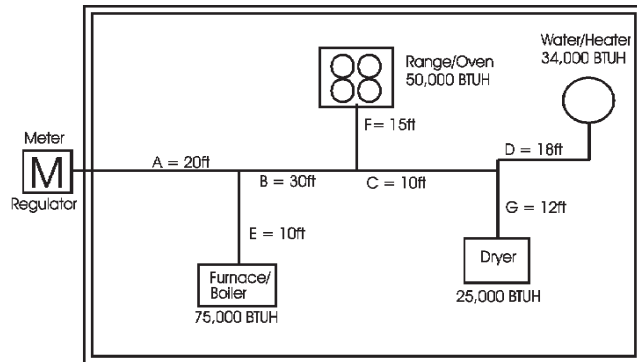

Hybrid System

Appliance Loads	Lengths	Tube Size
-	A = 20 ft.	1" Black Iron
-	B = 30 ft.	3/4" Black Iron
-	C = 10 ft.	3/4" Black Iron
Oven/Range = 50 CFH	D = 18 ft.	PGP-8 (1/2")
Furnace = 75 CFH	E = 10 ft.	PGP-12 (3/4")
Dryer = 25 CFH	F = 15 ft.	PGP-16 (1")
Water heater = 34 CFH	G = 12 ft.	PGP-8 (1/2")
Total 184 CFH		

- Determine the total gas load for each appliance in cubic feet per hour:  
 Furnace..... 75 CFH (75,000 BTUH/1000 BTUH per CFH)  
 Oven/range ..... 50 CFH (50,000 BTUH/1000 BTUH per CFH)  
 Dryer..... 25 CFH (25,000 BTUH/1000 BTUH per CFH)  
 Water heater..... 34 CFH (34,000 BTUH/1000 BTUH per CFH)  
 Total..... 184 CFH
- Measure the length of each run and determine the maximum length from the meter to the farthest appliance.  
 A = 20 ft., B = 30 ft., C = 10 ft., D = 18 ft., E = 10 ft., F = 15 ft. G = 12 ft.  
 Furnace = A + E = 20 ft. + 10 ft. = 30 ft  
 Oven/range = A + B + F = 20 ft. + 30 ft. + 15 ft. = 65 ft.  
 Dryer = A + B + C + G = 20 ft. + 30 ft. + 10 ft. + 12 ft. = 72 ft.  
 Water heater = A + B + C + D = 20 ft. + 30 ft. + 10 ft. + 18 ft. = 78 ft.

**The longest run is from the meter to the water heater over 78 ft.**

- Sizing Section A – Length A must be sized to handle the total load of all appliances and the total pressure drop from the meter to the farthest appliance. The total appliance load is 184 CFH. Using the longest length sizing method, the length is 78 ft. to the water heater. Referring to Table 20 (7 inches WC inlet pressure and 1/2 inch WC pressure drop) under the 80 ft. length column (next longest length column), we find that 1 inch size black iron pipe has a flow capacity exceeding 184 CFH (220 CFH). Use 1 inch black iron pipe to run Section A.
- Sizing Section B – Section B must supply the water heater, dryer, and range. The total pressure drop for the system is considered to be from the meter to the water heater [farthest appliance]. The total appliance load is 34 + 25 + 50 = 109 CFH. Using the longest length sizing method, the length is 78 ft. (distance from meter to water heater). Referring to Table 20 under the 80 ft. length column, we find that size 3/4 inch black iron pipe has flow capacity over 109 CFH (118). Use 3/4 inch black iron pipe to run Section B.

**3.2.6 Parflex System / Steel Pipe Hybrid System Example - Continued**

5. Sizing Section C – Section C must supply the water heater and dryer. The total appliance load is  $34 + 25 = 59$  CFH. Using the longest length method, the length is 78 ft. Referring to Table 20 under the 80 ft. length column, we find that 3/4 inch black iron pipe has flow capacity above 59 CFH (118). Use 3/4 inch black iron pipe to run Section C.
6. Sizing Section D – Section D supplies the water heater. The total load is 34 CFH and the total length is  $20 \text{ ft.} + 30 \text{ ft.} + 10 \text{ ft.} + 18 \text{ ft.} = 78 \text{ ft.}$  Refer to Table 1 under the 80 ft. column. We find that 1/2 inch (PGP-8) has capacity of 34 CFH (34). Use 1/2 inch (PGP-8) to run Section D.
7. Sizing Section E – Section E supplies the furnace/boiler. The total load is 75 CFH and the total length is  $10 \text{ ft.} + 20 \text{ ft.} = 30 \text{ ft.}$  Referring to Table 1 under the 30 ft. column, we find that 3/4 inch (PGP-12) has capacity above 75 CFH (96). Use 3/4 inch (PGP-12) to run Section E.
8. Sizing Section F – Section F supplies the range/oven. The total load is 50 CFH and the total length is  $20 \text{ ft.} + 30 \text{ ft.} + 15 \text{ ft.} = 65 \text{ ft.}$  Referring to Table 1 under the 70 ft. column, we find that 1 inch (PGP-16) has capacity above 75 CFH (157). Use 1 inch (PGP-16) to run Section E.
9. Sizing Section G – Section G supplies the dryer. The total load is 25 CFH and the total length is  $20 \text{ ft.} + 30 \text{ ft.} + 10 \text{ ft.} + 12 \text{ ft.} = 72 \text{ ft.}$  Referring to Table 1 under the 80 ft. column, we find that 1/2 inch (PGP-8) has capacity above 25 CFH (34). Use 1/2 inch (PGP-8) to run Section G.



3.2.7 Summation of Pressure Drops Method

Fuel gas piping systems must provide sufficient volume and pressure to all appliances in the system. The sizing methods described in this guide provide a minimum of 5 inches WC for natural gas appliances. Pressures less than 5 inches WC may be sufficient but should be referenced with the appliance manufacturer’s input rating and the local authority.

Parflex sizing tables for natural gas systems should be used to provide no less than 5 inches WC to each appliance. (The minimum inlet pressure for most natural gas appliances is 4 inches WC.) To ensure the minimum of 5 inches WC is delivered to each appliance, subtract 5 inches WC from the supply pressure at the meter (typically 8 inches WC). The difference is the allowable pressure drop for the system. Example: 8 inches - 5 inches = 3 inches WC. Use the 3 inch pressure drop table for natural gas.

Summation Example

In the following example, the piping is arranged in parallel with individual CSST appliance runs supplied by a main distribution manifold. The natural gas supply pressure is 7 inches WC and the lowest continuous inlet pressure required by any appliance is 5 inches WC. The maximum allowable pressure drop from the meter to the farthest appliance is 2 inches WC. When using the Summation Method for gas pipe sizing, the sum of the pressure losses through each section of pipe should result in a minimum 5 inches WC pressure delivered to the appliance inlet.

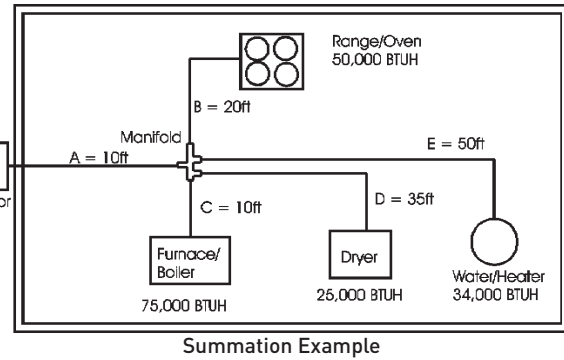

Appliance Loads	Lengths	Tube Size
-	A = 10 ft.	PGP-12 (3/4")
Oven/Range = 50 CFH	B = 20 ft.	PGP-8 (1/2")
Furnace = 75 CFH	C = 10 ft.	PGP-8 (1/2")
Dryer = 25 CFH	D = 35 ft.	PGP-8 (1/2")
Water heater = 34 CFH	E = 50 ft.	PGP-8 (1/2")
Total 184 CFH		

- Sizing Section A – Section A is sized by the total load of all appliances and the section length. The total load of all appliances is 50 + 75 + 25 + 34 = 184 CFH. The length of section A is 10 ft.

Referring to PGP Pressure Drop Table for Summation Method, for a 184 CFH load, 3/4 inch PGP has a drop of 0.064 inches WC per ft. The pressure drop over section A is: 0.064 in. x 10 ft. = 0.640 inches WC.

The available pressure at the end of Section A is 7" WC - 0.640" WC = 6.360" WC.
- Sizing Section B – Section B is sized by the load of the supplied appliance and the section length. The load of the range/oven is 50 CFH. The length of section B to the range/oven is 20 ft. Referring to PGP Pressure Drop Table for Summation Method, a 50 CFH load, 1/2 inch PGP has a drop of 0.015 inches WC per ft. The pressure drop over Section B is: 0.015 x 20 ft = 0.300 inches WC. The available pressure at the end of section B is 6.360 inches WC - 0.300 inches WC = 6.060 inches WC.
- Sizing Section C – Section C is sized by the load of the supplied appliance and the section length. The load of the furnace is 75 CFH. The length of section C is 10 ft. Referring to PGP Pressure Drop Table for Summation Method for a 75 CFH load, 1/2 inch PGP has a pressure Drop 0.040 inches WC per ft. The pressure drop over Section C is: 0.040 x 10 ft. = 0.400 inches WC. The available pressure at the end of section C is 6.360 inches WC - 0.400 inches WC = 5.960 inches WC.
- Sizing Section D – Section D is sized by the load of the supplied appliance and the section length. The load of the dryer is 25 CFH. The length of section D is 35 ft. Referring to PGP Pressure Drop Table for Summation Method, for a 25 CFH load, 1/2 inch PGP has a drop of 0.010 inches WC per ft. The pressure drop over section D is: 0.010 x 35 ft. = 0.350 inches WC. The available pressure at the end of section D is 6.360 inches WC - 0.350 inches WC = 6.010 inches WC.
- Sizing section E – Section E is sized by the total load of all supplied appliances and the section length. The total load of the Water Heater is 34 CFH. The length of Section E is 50 ft. Referring to PGP Pressure Drop Table for Summation Method, for a 34 CFH load, 1/2 inch PGP has a drop of 0.010 inches WC per ft. The pressure drop over section E is: 0.010 x 50 ft. = 0.500 inches WC. The available pressure at the end of section E is 6.360 inches WC - 0.500 inches WC = 5.860 inches WC.



3.2.8 Elevated Dual Pressure System

This is a 2 psig supply pressure parallel arrangement. This system is similar to example 3 except that the fuel gas is propane and the run from the meter to the reducing regulator is a long distance (200 ft.). The pressure downstream of the meter is 2 psig and the maximum pressure drop from the meter to the reducing regulator is 1.0 psig. The outlet pressure from the reducing regulator is set at 11.0 inches WC. A 1/2 inch WC pressure drop is used in sizing the tubing from the outlet of the reducing regulator to each appliance. The specific gravity of the gas is 1.52 and the energy content is 1 CFH = 2,500 BTUH.

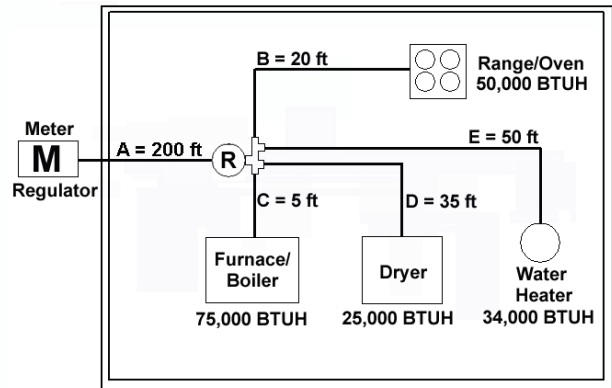

Elevated Dual Pressure Propane System

Appliance Loads	Lengths	Table Size
Meter To Regulator	A = 200 ft.	PGP-8 (1/2")
Oven/range = 20CFH (50,000 BTUH/2500)	B = 20 ft.	PGP-8 (1/2")
Furnace = 30 CFH (75,000 BTUH/2500)	C = 5 ft.	PGP-8 (3/8")
Dryer = 10 CFH (25,000 BTUH/2500)	D = 35 ft.	PGP-8 (3/8")
Water Heater = 13.6 CFH (34,000 BTUH/2500)	E = 50 ft.	PGP-8 (1/2")

- Total Load and Regulator Size**— Calculate the total appliance load and determine if one regulator has sufficient capacity. The total load is 73.6 CFH (184,000 BTUH). The supply pressure from the meter/ primary regulator is 2 psig and the pressure drop from the meter to the reducing regulator is 1.0 psig; therefore, the inlet pressure to the reducing regulator is 1.0 psig. Since the outlet pressure of the reducing regulator is set at 11.0 inches WC, the expected pressure drop across the regulator is 17 inches WC (1.0 psig - 11.0" WC = 17" WC). From the regulator pressure drop graph, we find that at a 17-inch WC pressure drop, a single 325-3 regulator has a flow rate capacity of 225 CFH for natural gas. This value must, however, be converted to a flow rate for propane with a specific gravity of 1.52. Using the specific gravity conversion factor table at the end of this section, we find that a multiplier is not shown for propane having a specific gravity of 1.52. Using the next higher gravity value of 1.60, we find that the multiplier is 0.61. Multiplying this value by the natural gas flow rate of 225 CFH, we obtain 137 CFH (225 CFH x 0.61). The 325-3 regulator has a propane flow capacity which exceeds the system requirement of 73.6 CFH.
- Sizing Section A (Meter to Reducing Regulator)**—Section A must have capacity to supply all appliances through the reducing regulator. The total load is 73.6 CFH (184,000 BTUH) and the distance is 200 ft. Referring to Table 12 (meter to regulator with 2 psig inlet and 1.0 psig drop) under the 200 ft. length column, we find that size 1/2 inch (PGP-8) has capacity above 184,000 BTUH (225,000). Use 1/2 inch (PGP-8) to run Section A. To size the remaining sections, the pressure source is the outlet of the reducing pressure regulator rather than the meter. Use the low-pressure Table 12 (11.0 inch WC inlet with 0.5 inch WC drop) for propane and size each section individually using the appliance load and run distance.
- Sizing Section B**—Section B supplies the oven/range. The load is 50,000 BTUH and the distance between the regulator outlet and the appliance is 20 ft. The total pressure drop from the regulator outlet to the appliance is 0.5 inch WC and the regulator output pressure is set at 11.0 inches WC. Referring to Table 12 under the 20 ft. length column, we find that size 1/2 inch (PGP-8) has capacity above 50,000 BTUH (106,000 BTUH). Use 1/2 inch (PGP-8) to run Section B.
- Sizing Section C**—Section C supplies the furnace with a load of 75,000 BTUH over a distance of 5 ft. Referring to Table 12 under the 5 ft. length column, we find that size 3/8 inch (PGP-6) has capacity above 75,000 BTUH (82,000). Use 3/8 inch (PGP-6) to run Section C.
- Sizing Section D**—Section D supplies the dryer with a load of 25,000 BTUH over a distance of 35 ft. Referring to Table 12, a 35 ft. length column does not exist. Use the 40 ft. length column and find that size 3/8 inch (PGP-6) has capacity above 25,000 BTUH (29,000). Use 3/8 inch (PGP-6) to run Section D.
- Sizing Section E**—Section E supplies the water heater with a load of 34,000 BTUH over a distance of 50 ft. Referring to Table 12 under the 50 ft. length column. We find that size 1/2 inch (PGP-8) has capacity above 34,000 BTUH (70,000). Use 1/2 inch (PGP-8) to run Section E.

**4.1 General Practices**

1. Use only components certified specified and supplied by Parker in the Parflex system. Care must be taken to follow the installation and assembly procedures exactly as outlined in this guide.
2. Care must be taken to ensure that all exposed Parflex Tubing and components are not damaged during building construction. All tubing, fittings, accessories and system hardware should be stored in a clean, dry location prior to installation.
3. Avoid stressing the tubing or fittings with tight bends, kinks, twists or excessive stretch.
4. Never use the Parflex Tubing and system components as a grounding electrode or as the grounding path for appliances or electrical systems.
5. Protect the Parflex tubing (CSST) from impact or contact with heavy or sharp objects which can crush or puncture the tubing. Avoid contact with corrosive chemicals, solder and fluxes containing acids and chloride compounds. Keep the jacketing in place as much as possible to reduce the chance of exposing the tubing to corrosion.
6. All unterminated ends of tubing must be plugged, capped or taped closed to prevent contamination with dirt, dust or other debris.
7. Avoid exceeding the minimum bend radius when installing Parflex Tubing.

PGP Tube Size	Recommended Min. Bend Radius (inches)
PGP-6 (3/8")	3
PGP-8 (1/2")	3
PGP-12 (3/4")	3
PGP-16 (1")	5
PGP-20 (1-1/4")	5

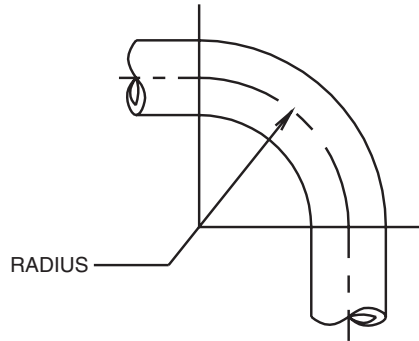

8. The Parker Parflex system is designed for use with fuel gas at operating pressures up to 5 psi. Avoid exposing the tubing to pressure tests above 100 psig. Do not expose regulators above 10 psi. Caution: If a one-part, high-pressure test is performed, the regulator must be removed to avoid regulator damage caused by overpressurization. What does one-part mean? Testing the entire system from meter or second stage reg. through to appliances.
9. Parflex (CSST) tubing must be supported with metal pipe straps, brackets, bands and pipe hangers suitable for the tubing size and weight. The use of metal pipe straps is preferred over plastic for best support and to comply with most codes in the USA and Canada. All tubing runs must be supported at the spacing intervals noted.

Tube Size	Horizontal and Inclined Runs	Vertical Runs
3/8" PGP-6	4 ft. Max.	Support at each floor with 10 ft. maximum spacing between supports
1/2" PGP-8	6 ft. Max.	
3/4" [PGP-12], 1" [PGP-16],	8 ft. Max. (USA) 6 ft. Max. (Canada)	

## 4.2 Fitting Assembly

Required Assembly Tools:

- 2 adjustable wrenches
- Stripping tool or utility knife
- Tubing cutters, PGPCT-SM and PGPCT-LG



### 4.2.1 Tube Preparation

1. **Rough cut** the Parflex tubing to the desired length using the special Parker cutter for the appropriate tubing size. Leave sufficient length for fitting attachment. **Note: For best performance, inspect cutter rollers periodically for cuts or damage. Replace the cutting blade when dull or worn.**

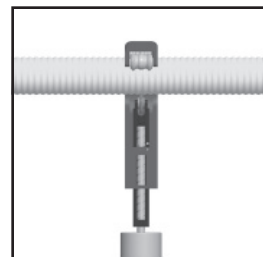

2. **Strip** the Parflex polymer jacket a minimum of 8 corrugations from the cut end using a utility knife, cable stripping tool, or when long strip-back lengths are required, by pulling the special zip string located under the polymer jacket. Remove the polymer jacket and trim the zip string.



3. Make the final precision cut on the stripped tubing using the Parker cutter. Check that your final cut leaves a minimum of 6 corrugations for fitting assembly. Use light roller pressure with extra tool revolutions and a sharp blade to produce clean cuts. Avoid excessive pressure which will distort the tubing, damage the rollers and wear the cutter blade. Visually inspect the end cut to verify that the tubing is round and free from burrs.

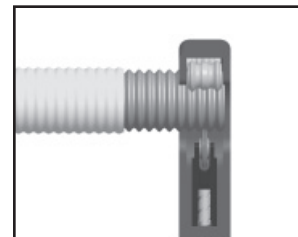

**Caution: Precision cuts made on a previously bent or twisted length of Parflex tubing may cause distorted or out-of-round tubing. For best results, ensure that all final end cuts are only made on straight lengths of tubing.**

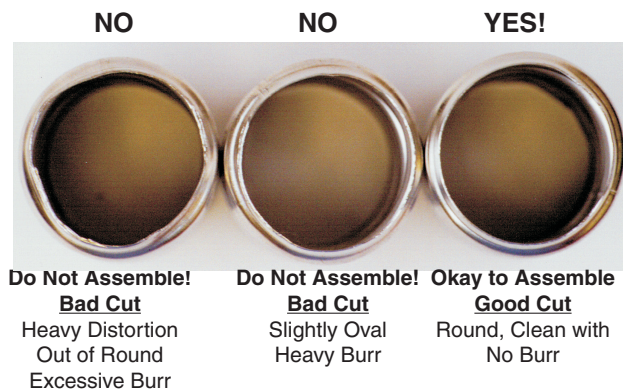

Assembly of Parflex FastMate Fitting and Parflex Tubing

4.2 Fitting Assembly - *Continued*

4.2.2 Straight Fitting Assembly

1. **Male pipe thread fittings**—First install the complete fitting to the port. **Do not apply a wrench to the nut.** (The fitting and nut assembly come pre-set from the factory. It is not necessary to remove the nut, pull tab, or to turn the nut until the tube has been inserted.)

Use a wrench on only the body hex near the pipe threads to install the fitting into the port.

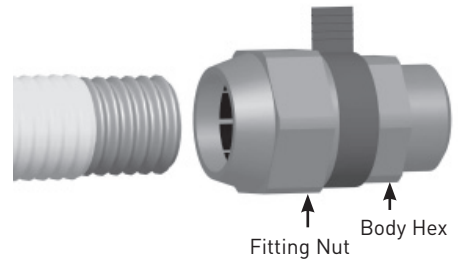

2. Align the tubing with the fitting and insert the tube into the fitting nut and through the fitting collet.
3. Push the tube forward with a slight rocking motion until bottomed (One corrugation). A click or ratchet sound should be heard as the tube corrugation passes through the collet. With a slight twist, pull off the spacer. Turn the nut by hand until tight. Complete tightening with a wrench until nut is very tight.

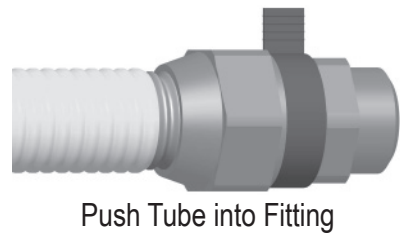

4.2.3 Flange Fitting Assembly

1. **Flange mount fittings**—Slide the Parflex tubing through the flat side of the flange. Assemble the tube to the fitting flange nut and body as described above for the straight fitting assembly.
2. While holding the flange nut of the fitting with a wrench, screw the flange snug onto the nut. Align the flange to the flange mount bracket and bolt. If the flange requires turning to center the holes, hold the flange nut with a wrench and turn the flange. **Do not twist the assembly. Damage could occur to the tube.**

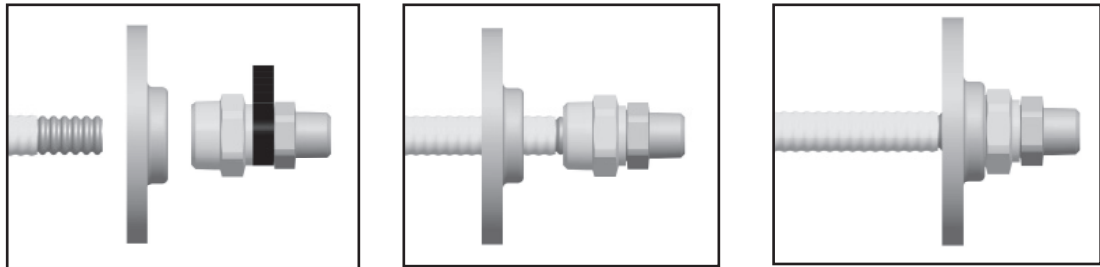

## Assembly of Parflex FastMate Fitting and Parflex Tubing

4.2 Fitting Assembly - *Continued*

## 4.2.4 Fitting Remake

## Fitting Removal - Before the nut is tightened with a wrench

1. Place the fitting nut to original position as if the spacer tab has not been removed.
2. Pull tubing from fitting.

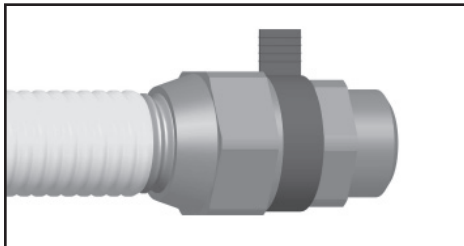

Inserted

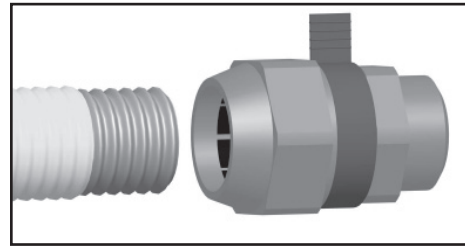

Pull tube out

## Fitting Removal - After the nut has been tightened with a wrench

1. Remove fitting nut with tubing. Remove polymer jacket 3 inches behind the nut. Cut the tubing 4 corrugations behind the fitting nut using the Parflex cutter.
2. When tubing is cut, push the short piece of tubing through the fitting nut and discard.
3. Tighten the fitting nut to spacer tab setting. Reassemble the nut to the body and reuse using assembly instructions.

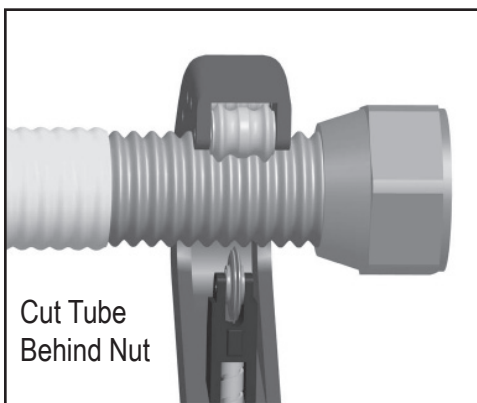
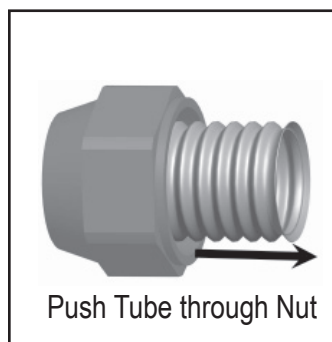
Cut Tube  
Behind Nut

Push Tube through Nut

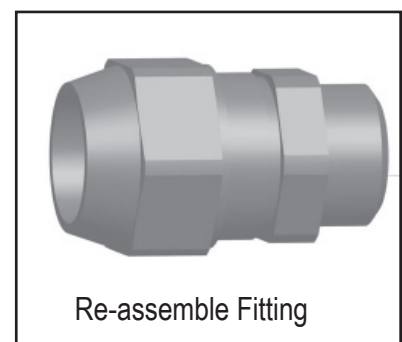

Re-assemble Fitting

**4.3 Routing**

**4.3.1 Vertical Runs**

Routing for vertical runs is preferred in hollow interior wall cavities. A carefully developed routing plan will eliminate the need for extra strike protection and comply with local building codes and to provide optimum protection for the Parflex tubing. The tubing should be supported ever 10 feet on vertical runs. When routing the tubing inside insulated exterior walls ensure the tubing will be routed between the paper facing of the insulation and the interior wall surface.

**4.3.2 Horizontal Runs**

**Horizontal and Inclined Runs** – Alongside of floor and ceiling joists, through floor and ceiling joists, and beneath floor joists are the most common routes. Careful consideration in routing must be given to future construction in unfinished basements, garages, and in areas where contact with exposed tubing could occur. Routing the Parflex tubing above or along ceiling joist is preferred in “slab-on-grade” construction where the shortest path and optimum protection is achieved by running tubing in the attic space. Tubing routed horizontally on structural members which meet the spacing requirement of 4 feet do not require support or strapping.

**4.3.3 Clearance Holes**

Clearance holes for routing the tubing are to be 1/2 inch greater than the O.D. of the tubing. Follow all building codes when drilling through structural members. Use caution not to exceed the minimum bend radius when installing the tubing.

Parflex Tube Size	Installation Drill Hole Diameter (Inch)
PGP-6 (3/8")	1-1/8"
PGP-8 (1/2")	1-3/8"
PGP-12 (3/4")	1-1/2"
PGP-16 (1")	1-3/4"
PGP-20 (1-1/4")	2-1/4"

**4.3.4 Concealed Fittings**

Parker FastMate™ fittings have been tested and listed in accordance with ANSI LC1b for use in concealed spaces. Tee fittings provide a reliable connection for branch runs while union couplings permit quick repairs and length splices. Straight and elbow connectors can be used for concealed attachment to appliance valves. Special care should be taken to ensure that all concealed connectors are properly protected, sized and pressure tested following the procedures outlined in this guide. The use of concealed connections must comply with local building codes. A review of applicable codes is recommended. All other connectors such as shut-off valves, manifolds, regulators and quick disconnects must be installed in an accessible space.

4.3.4 Concealed Fittings - *Continued*

**Manifolds** — Manifold stations or load centers which include multipoint manifolds, regulators and shut-off valves must always be installed in accessible spaces.

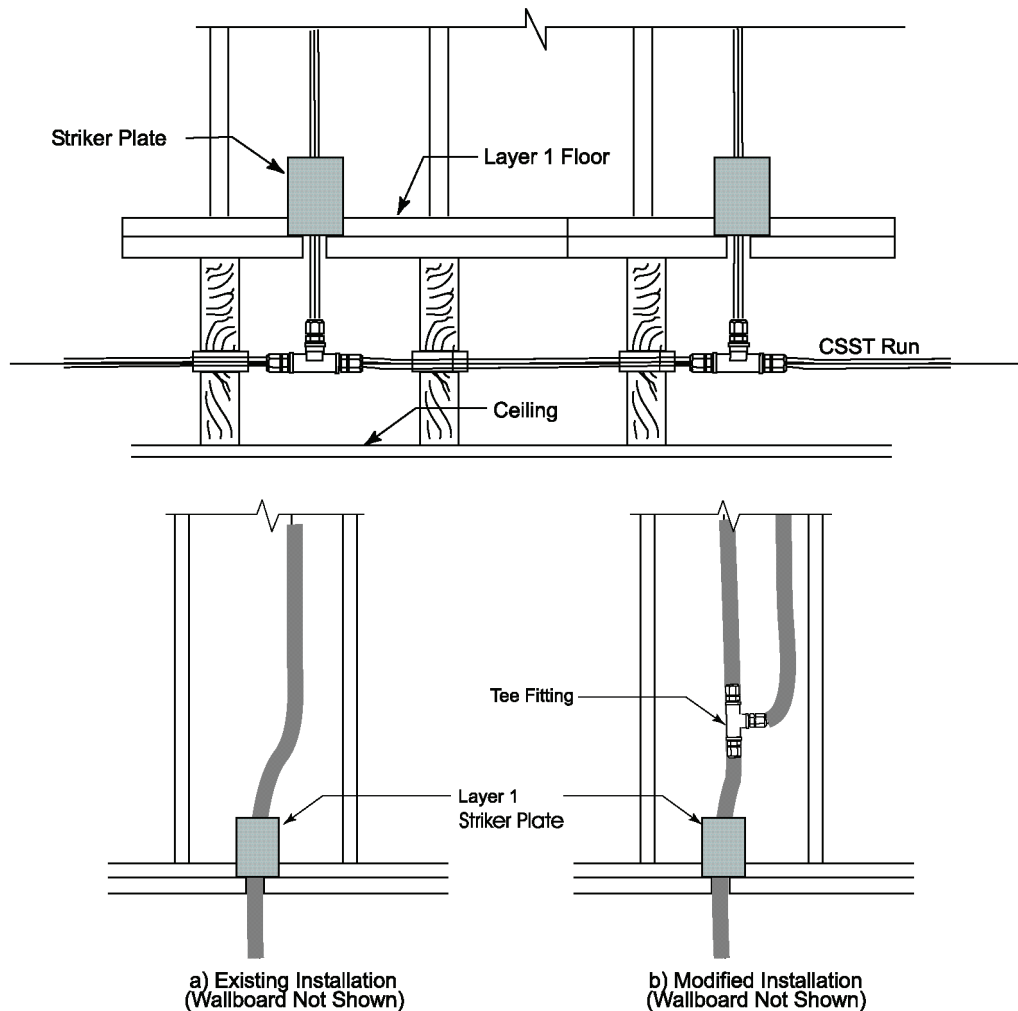

**Branch Outlets** — When multiple outlets are branched out from a single main run of Parflex (CSST), each branch is connected to the main using a tee fitting. Each tee can be located in a concealed space.

## 4.3.5 Modifying / Adding to Existing Piping Systems

**Modifying Installed Systems** — Extension of existing tubing runs can be made to allow for additional appliances provided sufficient capacity exists in the supply line. If accessible space is unavailable, the existing tubing must be modified with the addition of a tee fitting in the concealed space behind the finished wall, ceiling or floor board.

**Concealed Fittings in Unfinished Rooms** — Fittings and tubing originally installed in unfinished rooms, attics or basements can be concealed at a later date. Care must be taken to protect the newly concealed fittings and tubing from damage and accidental penetration. Follow the manufacturer's recommended procedures for installation of protection components such as striker plates and metallic conduit.

#### 4.3.6 Outdoor Routing

##### Guidelines for Installation of Parflex® (CSST) in Outdoor Applications

Parker Parflex tubing and fittings meet all performance requirements for outdoor applications and comply with ANSI LC1b specifications.

##### Precautions:

- For optimum performance in outdoor applications, the external polymer jacket on Parflex tubing (CSST) should not be removed. All exposed CSST should be protected by sleeving or wrapping with tape to prevent exposure to acids or chloride based solutions.
- Exposed tubing on the outside of a structure located between the ground and a 6-foot height must be protected in a sealed conduit or weather-tight chase which is routed and secured to avoid mechanical damage. If tubing is installed in a location where the tubing is not susceptible to damage, the conduit may not be necessary.
- When Parflex tubing must be buried underground or encased in cement (slabs, foundations, etc.), the tubing must be routed within a code approved, plastic watertight conduit. This nonmetallic conduit is to have an inside diameter 1/2 inch (1 inch in Canada) larger than the Parflex tube outer diameter. Exposed conduit ends must be sealed to prevent the entry of water and debris. Follow standard building code practices when routing Parflex in crawl spaces or underneath mobile homes.

#### 4.3.7 Routing through Fire Walls, Ducts, Plenums

If Parflex passes through fire walls or fire resistant construction, standard UL® approved practice is to remove the plastic jacketing for 2 feet on both sides of the wall and completely seal the penetration site with approved caulk or other code approved material for gypsum, masonry board or wood construction. Caulk must fill the entire annular space around the tube circumference for a nominal depth of 1 1/4 inches on each side of the gypsum wallboard. Only one run of tubing per penetration is permitted through the firewall. Review building codes and contact Parker for other approved methods.

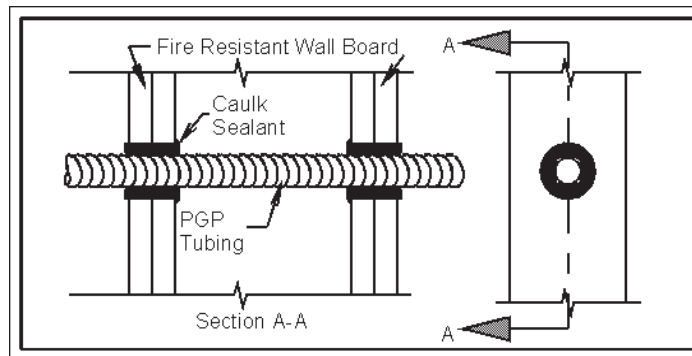

Routing and Sealing CSST through Fire Walls

If Parflex is routed through air ducts or plenums, building codes require the materials to meet ASTM 84 flammability ratings of 25 flame spread and 50 smoke density. The plastic Parflex jacket must be removed and the steel tubing labeled as “fuel gas line” in compliance with local building codes.



4.4 Strike Protection

Parflex CSST should be routed in areas to avoid penetration threats, physical damage and have the freedom to move. If Parflex tubing is constrained from movement, concealed from view, and within 3 inches of a penetration threat, strike protection must be installed.

4.4.1 Striker Plates

- Parker Parflex (CSST) must be protected from physical damage at support points and locations where the tubing passes through joists, studs, clamps and floor plates.
- A protection device must be installed at all locations where tubing is constrained from movement, concealed from view and within 3 inches of a potential penetration threat.
- At support points where tubing passes less than 3 inches away from the edge of a stud, joist or plate, a full or half striker plate must be installed to shield the tubing over a 5-inch protection length on each side of the support.

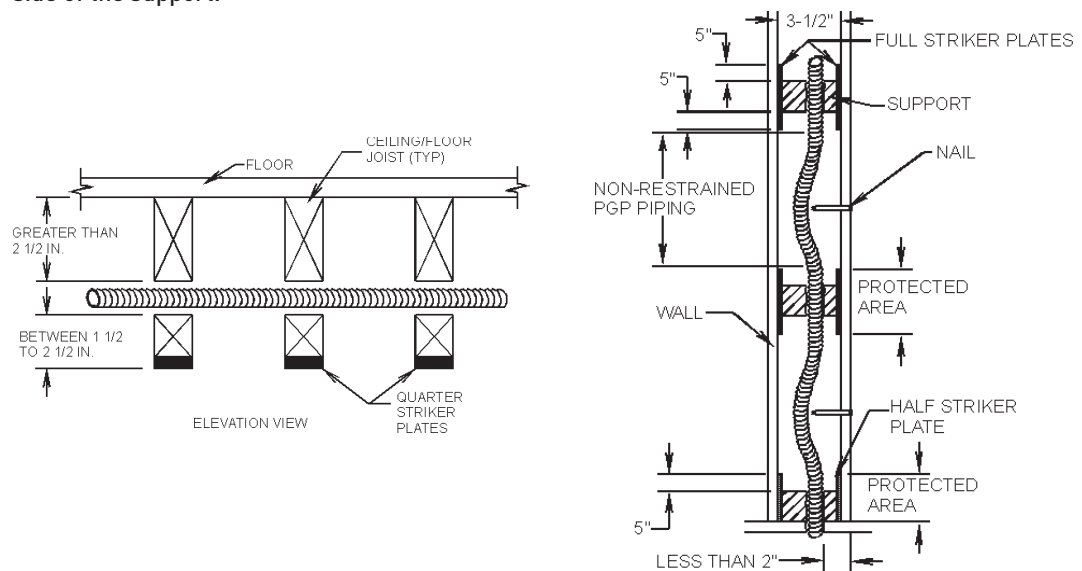

Protective Striker Plates Required

- When Parflex CSST tubing is routed through insulated exterior walls, the tubing must be run between the face of the insulation and the interior wall surface. A half striker plate must also be installed.

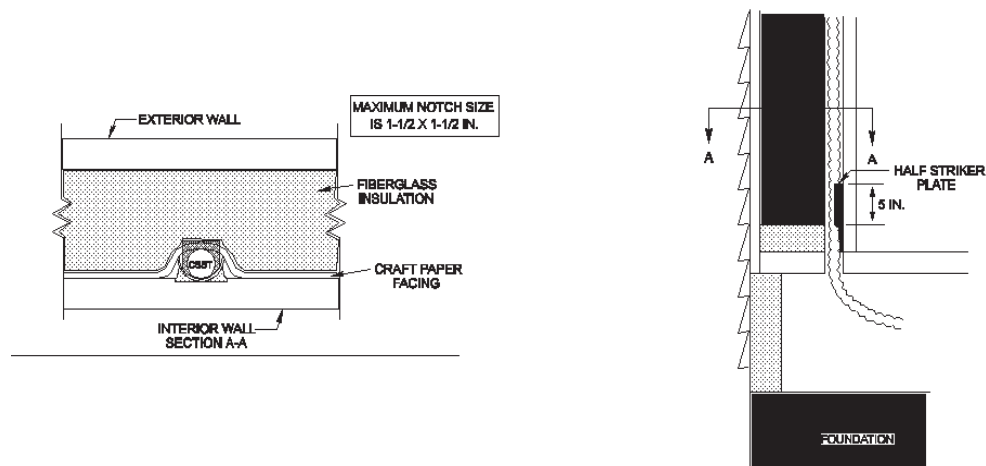

- Shielding is not required at support points where the tubing is more than 3 inches away from any edge, joist or plate and where unrestrained tubing has the freedom to move more than 3 inches away from a possible point of penetration by a nail, screw or drill bit.

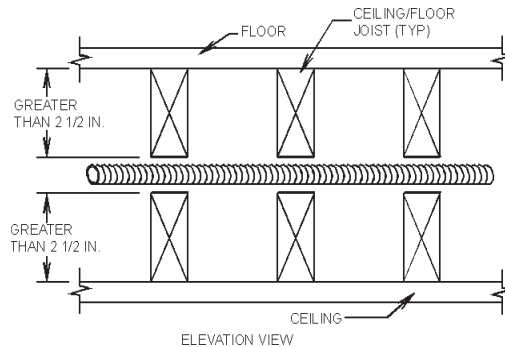

No Striker Plates Required

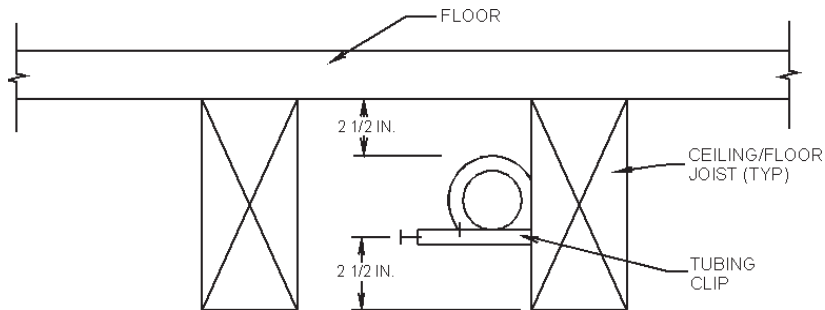

- When multiple runs of tubing are located between two studs or joists, panel striker plates PSP (6" x 17") can be used as an alternative to individual striker plates. Plates are commonly used near the mounting side of manifolds and branch.

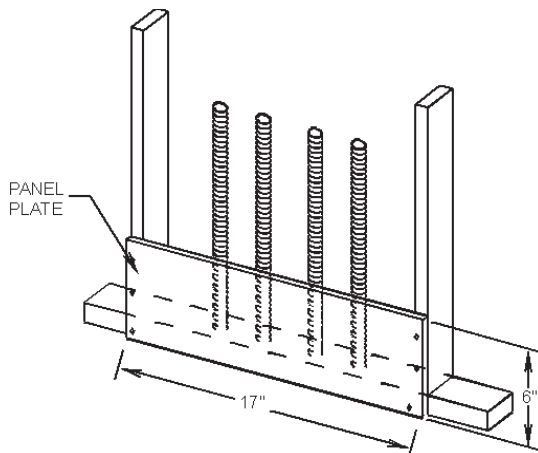

Panel Striker Plates Covering Vertical Tubing Runs Between Studs

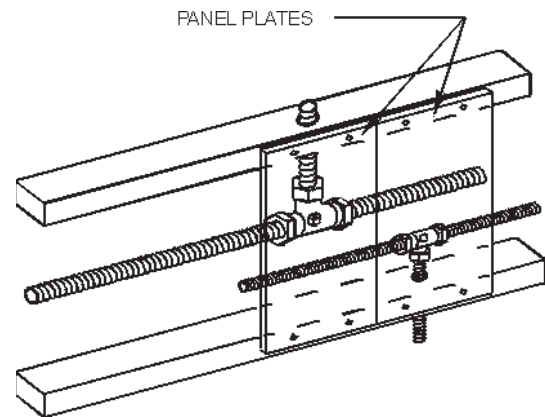

Panel Striker Plates Covering Branch Tees in Rafter or Floor Joist Runs

## 4.4.2 Metallic Conduit

Use strip-wound metallic conduit as an additional tubing protection device at support points, near flange termination outlets and where tubing is run horizontally between studs. Route the Parflex tubing in metallic conduit to provide extra protection from penetration from screws, nails and drill bits and to reduce the possibility of crushing in areas where tubing is exposed. Metallic conduit should only be used for protection in interior spaces.

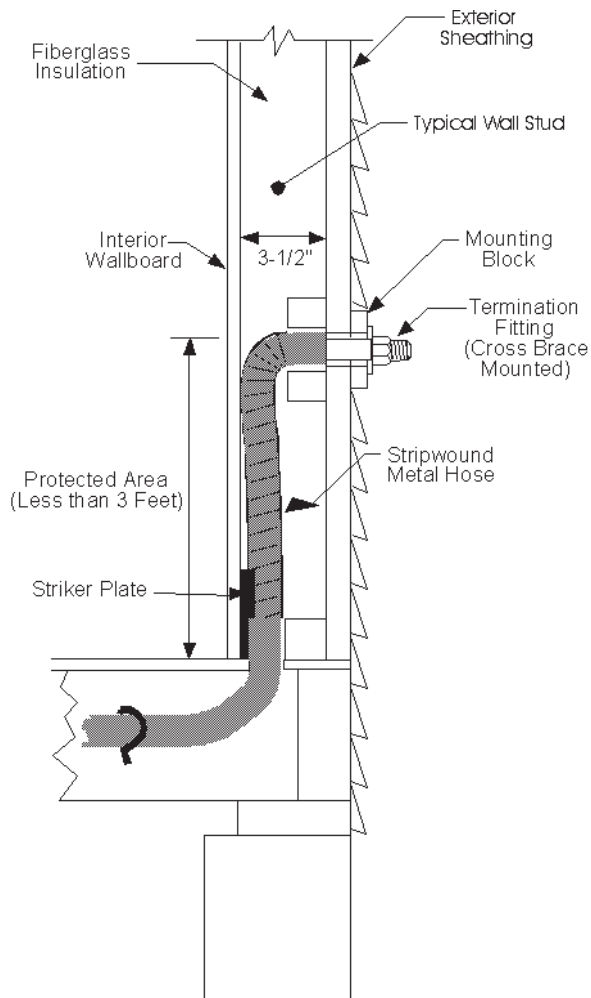

4.5 Meter Hookups

4.5.1 Self-Supported Meter

CSST can be directly connected to gas meters that are supported by brackets attached to the building structure or by framework dependent of the structure. On independently supported meters, Parflex CSST can in some locations be routed through the exterior wall and connected directly to the meter. Some utilities have their own specifications for meter attachment. Be sure to check with the local code officials and/or gas utility to ensure this is an acceptable practice in your area. Direct connections must provide a loop or slack in the tubing to account for building settling and meter movement. The wall penetration must also be properly sealed following code guidelines.

**Note:** Diameter of hole shall be at least 1/2 in. greater than O.D. of tubing and shall be sleeved in accordance with local building code (if applicable).

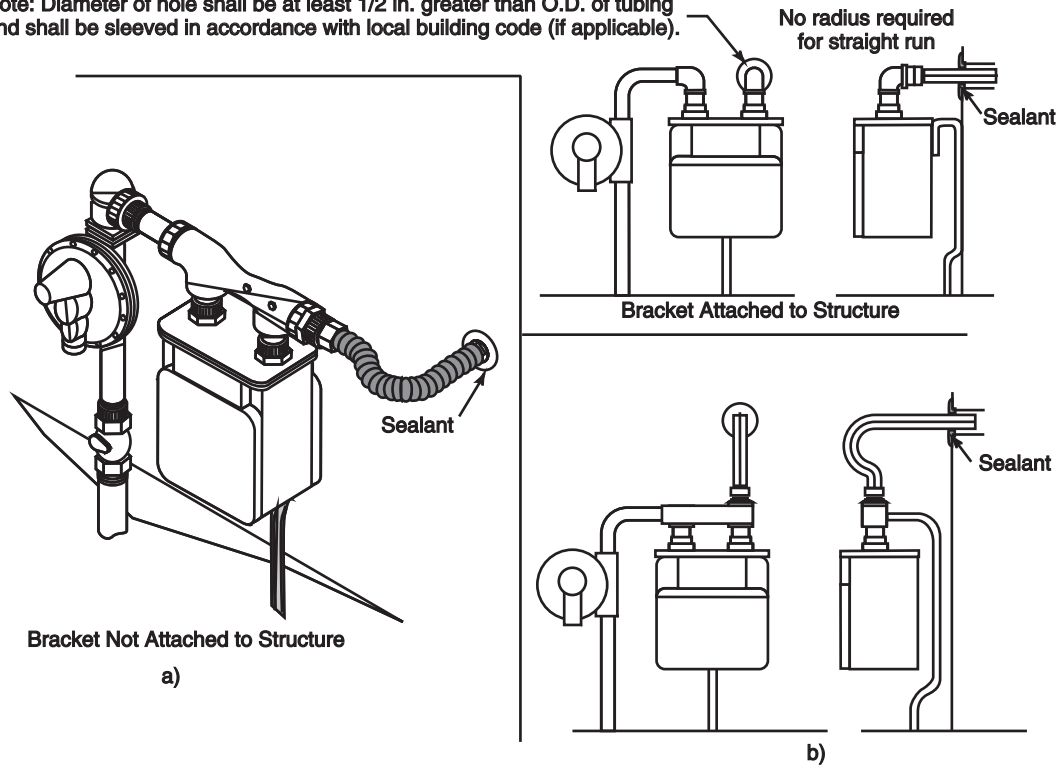

Independently Supported Gas Meter

Caution: Building codes vary. Check your local utility and building codes to verify that this meter connection practice is acceptable.

4.5.2 Pipe Supported Meter

Gas meters in some cases are supported by the service/supply line or by the interior piping system independent of the structure. Do not use Parflex tubing (CSST) as a direct connection to any meter which must be supported by the piping. On pipe supported meters, accepted practice is to connect the meter outlet to a termination flange mounted on the exterior wall, penetrate the exterior wall with a Parflex Meter Stubout or use steel pipe to provide a rigid attachment for the meter and Parflex tubing within the building.

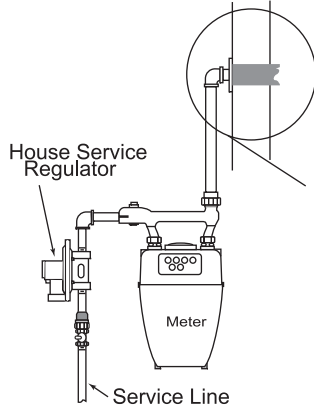
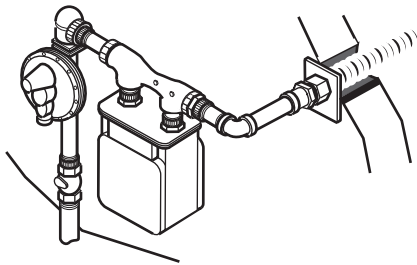

Note: Diameter of hole shall be at least 1/2 in. greater than O.D. of tubing and shall be sleeved in accordance with local building code (if applicable).

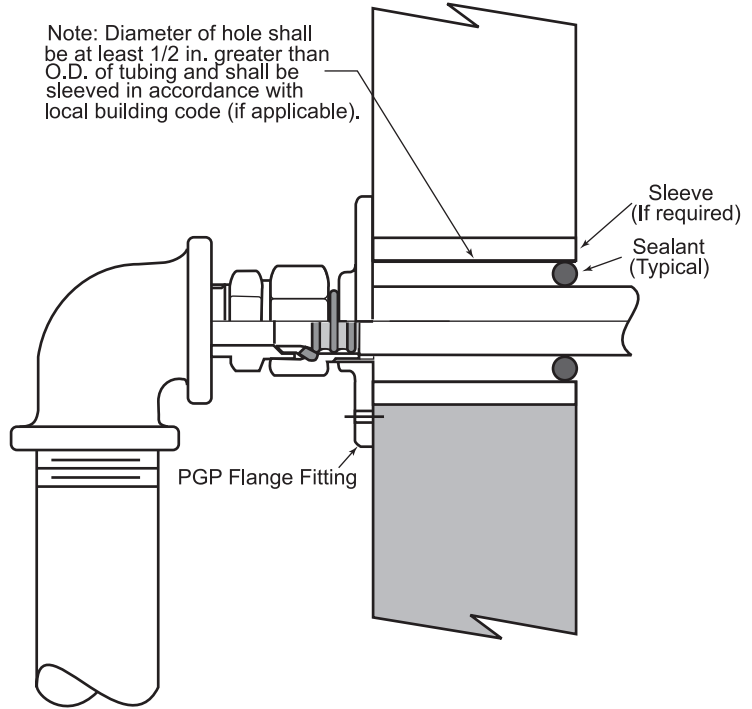

Building PIPING Supported Gas Meter

**4.6 Connections**

**4.6.1 Movable Appliance Connections**

**Terminations with appliance connectors:**

Movable appliances such as gas ranges and dryers must be connected to the CSST system using an approved appliance connector. Connection to the Parflex system can be made at a flange fitting terminated outside the wall eliminating concealed fittings. The straight or elbow appliance stub-out mounted to the stud face can be used to provide an unconstrained tubing connection away from penetration threats. The stub-out threads project approximately one inch past the wallboard for the areas where space is limited.

An appliance stubout (Parker Part No. AS01/2) can also be used to provide a rigidly mounted stubout for all movable appliances. This stubout gives only a 1 inch projection past the wall board in areas where space is limited.



**4.6.2 Non-Movable Appliance Connections**

**Direct Connections** — The Parflex system may be directly connected to non-movable appliances such as furnaces, boilers, water heaters and permanently mounted ranges or cook-tops. This direct connection eliminates the need for a termination or appliance connector. The term direct connections is not to eliminate the need for drip legs or shut-off valves where required by code.



**4.6.3 Specific Applications**

**Barbecue Grills**

- Connections to movable grills must be made by terminating the Parflex System (see section 4.6.1 Movable Appliance Connections) and using an outdoor appliance connector.
- The Parflex system provides a quick disconnect device (part number **GASOUTLET** shown below which can be used for connection to barbecue grills).

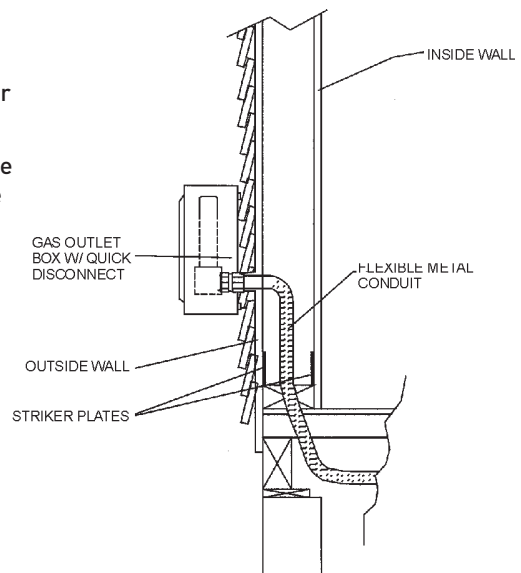
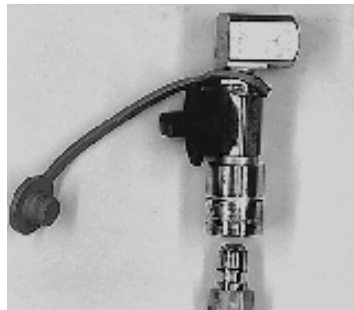

**Outdoor Appliances**

- Permanently mounted grills, appliances and gas lights located on exterior decks should be connected to the Parflex system following manufacturer's instructions. Exposed Parflex tubing should be supported against deck joists. If the deck elevation is below the top of the foundation or if the tubing is subject to contact, the tubing should be protected in weather-tight nonmetallic conduit. Building penetrations must be sealed to comply with all local codes.

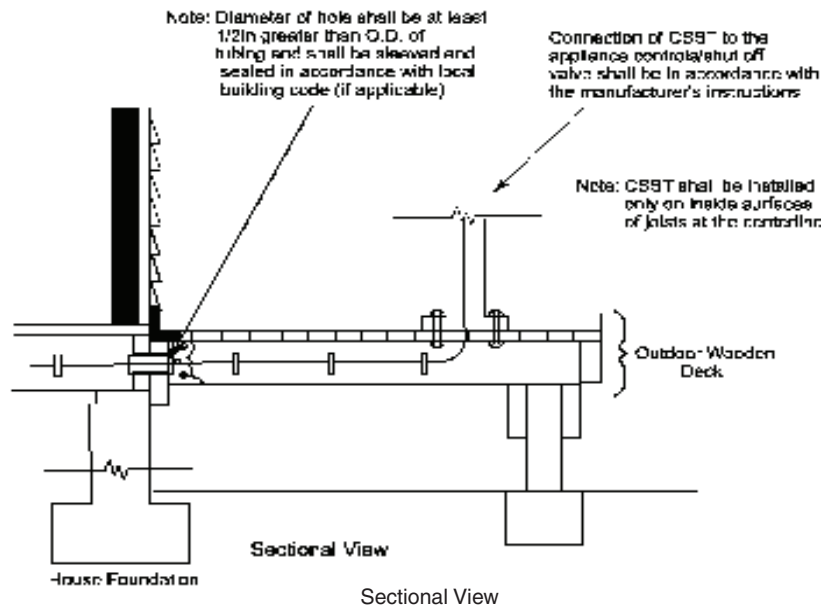

**Exterior Infrared Heaters**

- Infrared heaters rigidly mounted on interior/exterior walls or ceilings must be connected to the Parflex system in compliance with local codes and in accordance with manufacturer's instructions. The Parflex CSST should be mounted to the fixed end of the heater to avoid expansion and contraction that occurs.

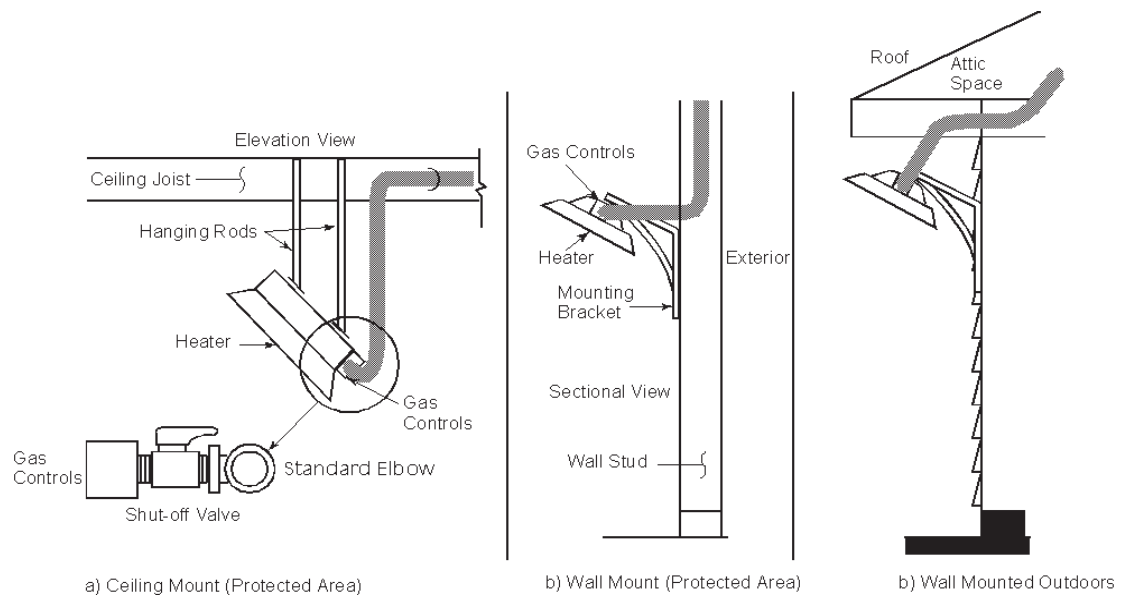



**Roof Mounted Equipment**

- Connection of Parflex (CSST) to roof mounted equipment should follow local codes and manufacturer's instructions. Standard roof penetrations should be close (approximately 6 ft.) to the appliance and sealed to prevent the entry of water. When long lengths of Parflex (CSST) are run exposed on a roof, common practice is to support the tubing every 6 feet with nonmetallic blocks which raise the tubing off the roof or a distance specified by local code.

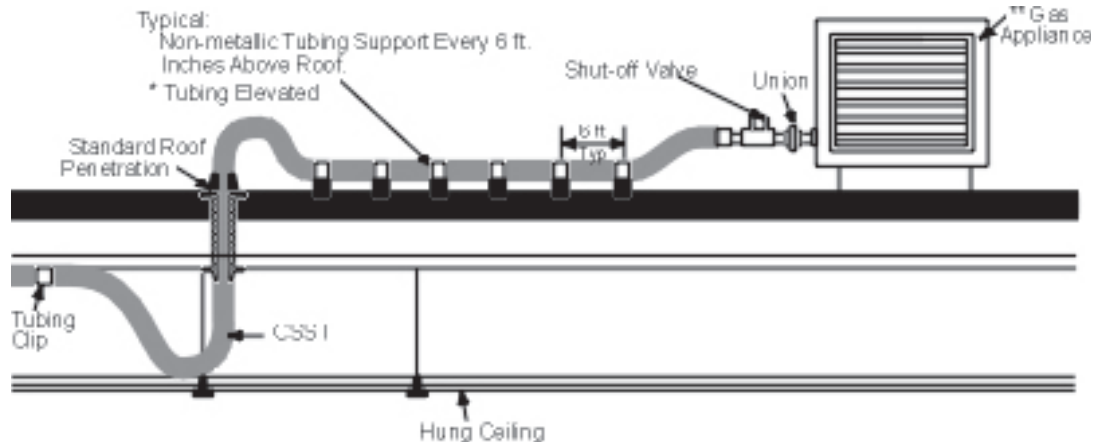

\* Height of elevation based on local plumbing/building code requirements and/or winter ice buildup.

\*\* When the equipment manufacturer requires the use of a flexible connector, the CSST shall be installed as shown in "Pad Mounted Equipment" section.

**Pad Mounted Equipment**

- Gas appliances mounted on exterior block foundations or concrete pads such as air conditioners, heat pumps, pool heaters or natural gas fueling stations must be connected to the Parflex (CSST) system at a flange fitting or stubout using rigid pipe or a code approved, outdoor appliance connector.

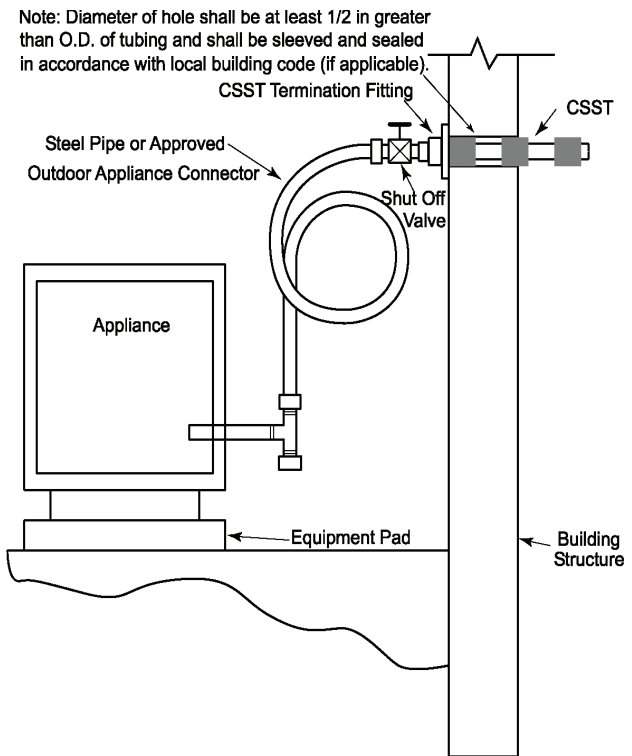

**Gas Fireplaces**

- **Parflex CSST can be routed directly to the shut-off valve of a gas fireplace.** Parflex can also be used for fuel delivery to gas fireplace inserts and decorative fireplace heaters.
- **Parflex CSST should not be routed within the fire box of gas wands, log lighters or near wood and composite logs where tubing damage can occur caused by crushing and excessive heat.**
- Parker FastMate fittings are approved for use as connections in concealed spaces. Connections can be made directly to the flow control and shut-off valves in fireplace appliances. Parflex tubing, FastMate fittings and valve connections can be installed in concealed spaces beneath floors and hearth or behind walls and fireplace brick work.
- When routing the Parflex CSST through masonry walls, do not remove the plastic jacketing. Route tubing through appropriate sleeving and caulk the penetration of the masonry wall. All exposed plastic jacketing should be removed within the fire box using a knife and the Parflex zip strip.
- Protective sleeving is not required when routing Parflex CSST through ceramic liners used in decorative heat generating fireplace fixtures.
- Parflex CSST routed through sheet metal enclosures should be protected from wear caused by vibration. Tubing should be routed and supported to prevent contact with the metal enclosure. Protection devices such as grommets, flexible steel conduit, conduit and rigid steel pipe can be used through knock-out holes in the metal enclosure where appropriate. Materials used in fire-rated constructions must meet applicable codes.

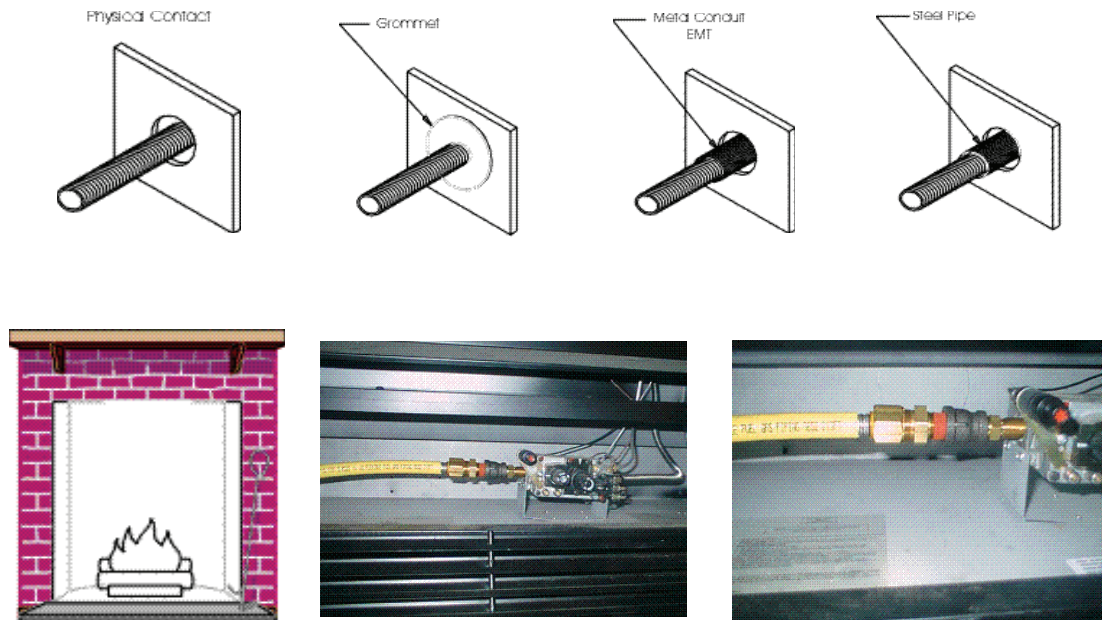

- On occasion, the routing and configuration of CSST and flexible appliance connectors, which feed a gas log lighter, fireplace or gas log set, can whistle due to high velocity gas flow. Whistling can often be avoided by minimizing the number of tubing bends and increasing the size of the supply line. Determination of the supply line size can be made using the maximum flow capacities shown below.

Fireplace Appliance Max. Load	45,000 BTUH (45 CFH)	83,000 BTUH (83 CFH)	178,000 BTUH (178 CFH)
Minimum tubing size recommended	1/2"	3/4"	1"

4.7 Manifold Stations

4.7.1 Configurations

- The manifold regulator and shut-off valves must be securely installed into a ventilated accessible space to allow for inspection, service and replacement. An extra port must be included on the manifold for system pressure testing.
- If the manifold regulator assembly is installed into a built-in enclosure, all tubing penetrations in the cabinet must be sealed, caulked or grommeted. Ventilation of the cabinet must be through the access panel and not into the wall space. A review of local building codes is recommended.
- Manifolds not attached directly to a regulator or shut-off valves can be located in a concealed location.

4.7.2 Allowable Locations

- Distribution manifolds are often used in parallel system layouts where the manifold is located close to the appliance with the highest load. Approved manifolds include one-piece malleable iron or brass castings, welded steel, or assemblies made from approved malleable iron tees and short nipples.
- The location of the manifold depends on space limitations, appliance locations, and code regulations.
- Common mounting configurations illustrated below include surface mounting to interior walls, between open floor joists, between ceiling joists in attic spaces and within partition walls using a ventilated enclosure.

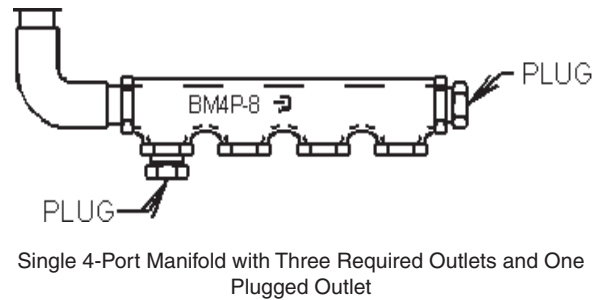
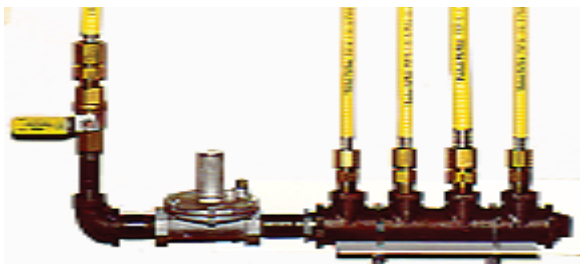

Single 4-Port Manifold with Three Required Outlets and One Plugged Outlet



Manifold Expansion Methods  
(For Additional Appliances and Pressure Testing)

## 4.8 Line Pressure Regulators

### 4.8.1 Installation Requirements

On Parflex (CSST) systems having supply pressure exceeding 1/2 psi (14" WC), a regulator must be installed downstream to limit appliance supply pressure to a maximum of 1/2 psi (14" WC). The regulators currently certified for uses with Parflex are Maxitrol type 325-3L and 325-5A.L. At supply pressures in excess of 2-psi, ANSI Z21.80 line regulator standard requires an approved and tested OPD (over-pressure protection device) as a means to limit the downstream pressure to 2-psi maximum, in the event of regulator failure.

- a. All regulators must be installed following the manufacturer's instructions and placed in a fully accessible area. It is recommended that the regulator be installed in a horizontal (stem up) position when a vent limiter device is used. A shut-off valve should be installed ahead of the regulator, and union connectors should be used in the piping system to allow for removal of the regulator.
- b. The capacity of the regulator selected should exceed the total appliance load requirements. Refer to regulator data in Section 2.0, "System Components," of this guide.

### 4.8.2 Venting

#### Vent Limiting Device

- All Maxitrol 325-3L and 325-5AL regulators must be vented to the outdoors or equipped with vent limiters.
- The vent limiting device can only be used when vented gas is discharged to an open, well-ventilated area. Local codes shall take precedence in determining how regulators must be vented.
- Do not check the vent limiter with liquid test solutions as this will contaminate the device and cause erratic operation.
- If the regulator is used in an outdoor installation, the preferred practice is to remove the limiter and install the regulator upside down (stem down) to allow drainage and to prevent water from getting into the regulator.

#### Vent Line Sizing

- When a vent line is used, the line must be less than 30 feet long and sized to meet or exceed the regulator vent port size. The vent line should be designed and routed to prevent the entry and accumulation of water, insects and other foreign material which could block the line. **Never vent the regulator to an appliance flue, drain or building exhaust system.**

### 4.8.3 Adjustments

- Regulators can be adjusted to deliver different outlet pressures within a limited range. To access the adjustment screw, first remove the seal cap. Turning the screw clockwise increases outlet pressure while turning counterclockwise will decrease outlet pressure.
- Always replace the seal cap after making a regulator adjustment. If adjustments do not produce the desired outlet pressure, check the inlet supply pressure, remove the regulator from service and consult the factory. Do not continue to turn adjustment screw clockwise if outlet pressure does not increase. This may cause a regulator malfunction due to a loss in pressure control.
- The common 2 psi system line regulator can be adjusted with an outlet pressure ranging between 6 and 10 inches of water column. The regulator must be adjusted according to the manufacturer's recommended procedure. A pressure gauge mounted downstream of the regulator monitors the set pressure under various loads.
- The average natural gas appliance is designed to operate at 3 to 4 inches water column pressure with a pressure drop of 1 to 2 inches of water column across the appliance regulator which prevents slow regulator response. Thus, the appliance will operate best at 5 to 6 inches water column inlet pressure. In this case, the 2 psi system regulator should be reset to deliver approximately 8 to 10 inches of water column outlet pressure under full load to allow for 3 inches of water column pressure drop in the Parflex tubing.
- Regulators supplied by Parker are factory set at 8 inches of water column output. Some appliances may have different inlet pressure requirements.

4.8.4 Over-Protection Device

- Gas systems with a pressure exceeding 2 psi must have a regulator with an over-protection device. This regulator OPD assembly must be assembled and listed by the manufacturer in accordance with Z21.80, Standard for High Pressure Regulators.

4.9 Underground Installations

Installation Requirements — CSST cannot be buried directly underground or embedded in concrete, When buried underground the tubing must be routed within a nonmetallic, watertight conduit having an inside diameter 1/2 inch larger than the outside diameter of the (CSST) tubing. The entry and exit ends of the conduit must be sealed or protected from the entry of water or contamination. No joints are permitted within the conduit, therefore venting of the conduit is not required per the manufacturers instructions.

Direct Burial — For permanently mounted grills and gas yard lights, Parflex tubing must be routed and connected in accordance with manufacturer’s instructions and code regulations. All Parflex tubing installed below grade must be protected in nonmetallic, weather-tight conduit. Exposed conduit ends must be sealed against the entry of water.

Direct Burial Accessories — Parker also offers Parflex direct burial polyethylene pipe, Permasert® couplings, anodeless riser assemblies and transition couplings for residential natural gas and propane service. Consult Bulletin PGP2-DB or contact factory at 1-888-FASTMATE for component and assembly details. Installation practices for direct burial polyethylene pipe and couplings are described in local codes and in chapter 3.0 of The National Fuel Gas Code (NFPA 54/ANSI Z223.1).

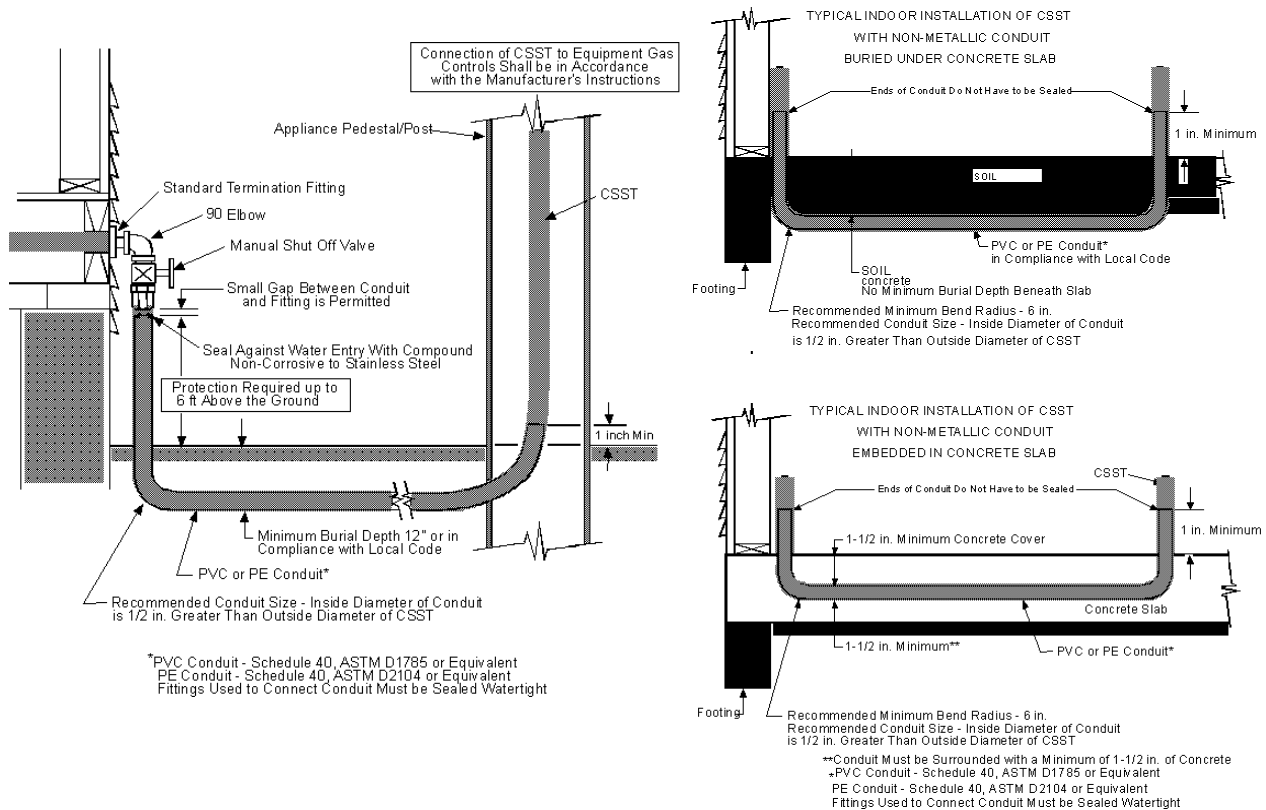

4.10 Electrical Bonding and Grounding

The piping system shall not be used as a grounding conductor or electrode for an electrical system. In accordance with the National Fuel Gas Code, "each above ground portion of a gas piping system upstream from the equipment shutoff valve shall be electrically continuous and bonded to any grounding electrode as defined by the national Electrical Code (ANSI/NFPA70)."

When Bonding the Parflex System, a bonding clamp may be attached to the brass mechanical fitting, steel manifold or to a black iron pipe component connected to the Parflex System. Bonding electrode conductro sizing shall be in accordance with Article 250 of ANSI/NFPA 70. The tubing portion of the gas piping system shall not be used as the bonding attachment point under any circumstances.

### 5.1 Minimum Inspection Requirements

## Parflex Flexible Gas Pipe Installation/Inspection Checklist

A checklist of the key installation practices that must be followed prior to pressure testing has been provided below. This checklist is intended to provide practices that if strictly adhered to should yield a positive inspection for both the installer as well as the local administrative authority.

- The installation was performed by a Qualified Installer.
- Proper sizing of the system has been completed
- All fittings and connections are properly tightened
- All gas outlets for appliance connections are capped
- CSST is not directly connected to a movable appliance
- All striker plates and protective devices are properly located and installed
- Tubing routed within 3 inches of a penetration threat is protected with a Protection Device.
- Regulators and shutoff valves are in a accessible location
- Regulators with a vent Limiting Device are mounted in a horizontal upright position
- All components in the system are from one manufacturer
- Appropriate sleeving for underground routings.
- Parflex Warning Tax installed on an interior component visible to the homeowner.

5.2 Repair of Damaged Tubing

5.2.1 Inspection

Inspect the tubing carefully to determine the type of damage which has occurred. Stripping the polymer jacket off of the damaged area is recommended.

1. Parflex must be repaired if the metallic tubing has been deeply nicked, cut or punctured.
2. Parflex must be repaired if the diameter in the damaged area has been crushed or dented to less than two-thirds of its original diameter.
3. Parflex must be repaired if the tubing has been permanently kinked or creased by twisting or bending beyond the minimum bend radius.
4. Do not attempt to assemble fittings onto any tubing ends which appear damaged by excessive stretching, bending, crushing or twisting.

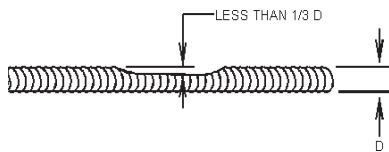

Repair unnecessary—No significant damage to the tubing due to minor impact or crushing.

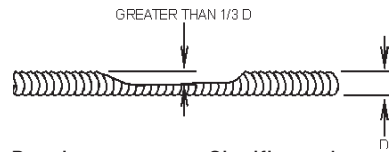

Repair necessary—Significant damage to the tubing due to impact or crushing.

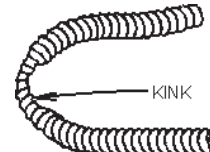

Repair necessary—Significant damage to the tubing due to bending beyond minimum bend radius.

5.2.2 Methods of Repair

Parflex repairs can be made by adding a line splice or straight coupling if the tubing length is short, easily accessible, and if enough slack exists to make up for the removed damaged length.

The preferred repair method is to replace the entire tubing length. Replacement is often faster than repairing a damaged section and eliminates additional fitting joints in the line.

**Do not attempt to seal, weld, braze, straighten, reshape or otherwise mend damaged CSST.** When repairs or replacements involve coupling CSST systems from different manufacturers, connectors must be joined using code approved standard pipe couplings and manufacturer’s recommended CSST couplings.

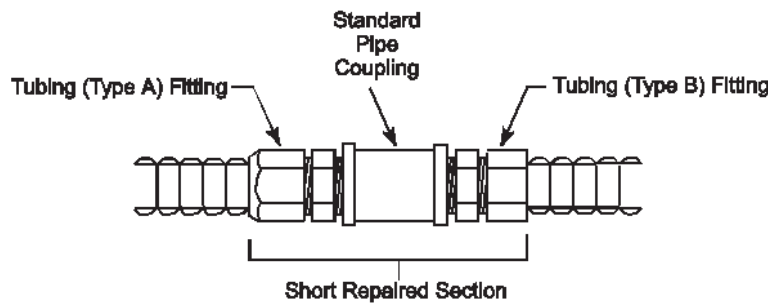

Repair of Damaged Tubing with Noncompatible System

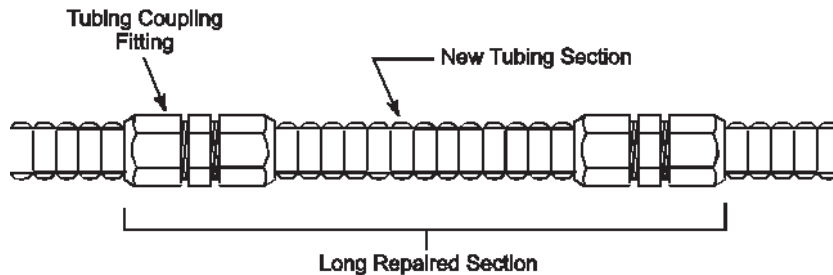
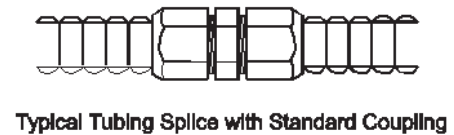

Repair of Damaged Tubing with a New Section of Tubing and Two Joint Splices



## 6.1 Testing Requirements

- 6.1.1 Low-Pressure Systems** — Inspection and testing of the final piping system must be performed in accordance with the code in effect. In the absence of the local code, the installation and testing of the final piping system must be in accordance with the latest edition of the National Fuel Gas Code, ANSI Z223.1/NFPA 54 (in Canada CSA-B149.1). (Pressurize system to 1-1/2 times the working pressure but not less than 3 psi.) Pressure testing must be performed during rough-in stage of construction (prior to finishing of interior walls). All appliance terminations must be capped for initial pressure testing.

An additional pressure or leakage test must be performed after construction is completed and interior walls are finished. This additional test assures that no damage was done to the tubing during the final close-in construction process and is required before gas service is turned on. This leakage test is usually performed by the gas utility when the meter is initially set.

**6.1.2 Elevated Pressure Systems**

**One-Part Test** — An elevated pressure system (2 psi) usually requires a 10 psi or greater air pressure test to comply with local codes. A one-part test may be performed (depending on local codes) by replacing the regulator with a suitable “jumper” pipe to allow elevated pressure testing of the entire system. **Caution: If a one-part, high-pressure test is performed, the regulator must be removed to avoid regulator damage caused by over pressurization.**

**Two-Part Test** — A two-part air pressure test may need to be performed as shown in Figure 6.1 with the regulator installed. The first test is performed on the elevated pressure section between the meter and the pounds-to-inches line regulator. A 5 psi test pressure is applied. The second test is performed on the low-pressure section between the outlet of the low-pressure regulator and the individual gas appliance outlets.

- 6.1.3 Appliance Connection and Leakage Check Procedure** — After final construction is completed and the piping system has passed both the pressure test and inspection, connect the appliances to the PARFLEX system using code approved flexible appliance connectors. Turn on the gas at the meter and inspect for leakage at each appliance connection before operating the appliances. Appliance connections should be leak checked using only a soapy water bubble solution.

**Caution:** Leak test solutions may be corrosive to some materials used in gas tubing systems. Be sure to rinse off leak test solutions with water and thoroughly dry all connections. **Do not leak test the regulator vent limiter with a liquid test solution.** This will contaminate the ball check mechanism or plug the breathing hole causing erratic regulator operation.

Before operating appliances, the tubing should be purged to remove air trapped in the tubing system. Always purge lines into a well ventilated area.

**Regulator Performance Testing** — A pressure measurement should be made at each appliance connection while operating all appliances at full load. This test assures that adequate pressure reaches each appliance under full-load conditions. The inlet pressure for typical natural gas appliances should measure a minimum of 4 1/2 inches of water column (10 inches WC for propane) under full-load conditions. If this pressure cannot be obtained, a slight adjustment to the low-pressure regulator is necessary to increase line pressure.

**7.1 CSST Tables**

**Natural Gas**

**Caution: Locate proper sizing table based on total pressure drop allowed in piping system by local utility for each installation.**

Table 1*																							
Maximum Flow Capacity of Parker Parflex Tubing in Cubic Feet per Hour Gas Pressure: 0.5 psi or less; Pressure Drop: 0.5 in. WC (Based on a 0.60 Specific Gravity Gas)																							
Part	Tube	Tubing Length (ft.)																					
No.	Size	5	10	15	20	25	30	40	50	60	70	80	90	100	125	150	200	250	300	350	400	450	500
PGP-6	3/8"	49	35	28	25	22	20	17	16	14	13	12	12	11	10	9	8	7	6	6	5	5	4
PGP-8	1/2"	119	87	72	64	57	53	47	42	39	36	34	32	31	28	26	23	20	19	18	17	16	15
PGP-12	3/4"	228	163	134	117	105	96	84	75	69	64	60	57	54	49	44	39	35	32	30	28	26	25
PGP-16	1"	601	422	343	297	265	241	208	186	169	157	146	138	130	116	106	92	82	75	69	64	61	57
PGP-20	1-1/4"	1037	746	615	536	482	442	386	347	318	295	277	262	249	224	205	179	161	148	137	129	122	116

Table 2*																							
Maximum Flow Capacity of Parker Parflex Tubing in Cubic Feet per Hour Gas Pressure: 0.5 psi or less; Pressure Drop: 1.0 in. WC (Based on a 0.60 Specific Gravity Gas)																							
Part	Tube	Tubing Length (ft.)																					
No.	Size	5	10	15	20	25	30	40	50	60	70	80	90	100	125	150	200	250	300	350	400	450	500
PGP-6	3/8"	66	48	40	35	32	29	26	24	22	20	19	18	17	16	15	13	12	11	11	10	10	9
PGP-8	1/2"	162	117	97	85	77	71	63	58	53	50	48	46	44	40	38	34	32	30	29	27	27	26
PGP-12	3/4"	326	233	191	166	149	137	119	107	98	91	85	80	76	68	63	54	49	45	41	39	37	35
PGP-16	1"	860	604	491	424	379	345	298	266	242	224	209	197	187	167	152	131	117	107	99	92	87	82
PGP-20	1-1/4"	1749	1258	1037	904	813	746	650	585	536	498	468	442	420	378	347	302	272	249	232	217	205	195

Table 3*																							
Maximum Flow Capacity of Parker Parflex Tubing in Cubic Feet per Hour Gas Pressure: 0.5 psi or less; Pressure Drop: 1.5 in. WC (Based on a 0.60 Specific Gravity Gas)																							
Part	Tube	Tubing Length (ft.)																					
No.	Size	5	10	15	20	25	30	40	50	60	70	80	90	100	125	150	200	250	300	350	400	450	500
PGP-6	3/8"	86	61	52	45	42	38	34	30	28	26	24	23	22	20	18	16	14	13	12	11	11	10
PGP-8	1/2"	205	147	122	106	97	89	79	74	67	64	62	57	57	52	50	45	44	41	40	37	37	36
PGP-12	3/4"	424	303	248	215	193	178	154	139	127	118	110	103	98	90	82	69	63	58	52	50	48	45
PGP-16	1"	1119	786	639	551	493	449	388	346	315	291	272	256	244	218	198	170	152	139	129	120	113	107
PGP-20	1-1/4"	1442	1037	885	746	671	615	536	482	442	411	386	364	347	312	286	249	224	205	191	179	169	161

\*Table includes losses for four 90 degree bends and two end fittings. To determine flow capacity for tubing runs with additional bends and/or fittings, add the appropriate number of feet to the actual run length using the formula: L = 1.3n. L = number of feet to be added to actual run length; n = number of additional bends and/or fittings.



**7.1 CSST Tables (Continued)**

**Natural Gas**

**Caution: Locate proper sizing table based on total pressure drop allowed in piping system by local utility for each installation.**

Table 4*																							
Maximum Flow Capacity of Parker Parflex Tubing in Cubic Feet per Hour Gas Pressure: 0.5 psi or less; Pressure Drop: 2.0 in. WC (Based on a 0.60 Specific Gravity Gas)																							
Part	Tube	Tubing Length (ft.)																					
No.	Size	5	10	15	20	25	30	40	50	60	70	80	90	100	125	150	200	250	300	350	400	450	500
PGP-6	3/8"	101	71	60	51	47	43	38	33	31	28	26	25	24	22	20	17	15	14	13	12	12	11
PGP-8	1/2"	234	172	143	123	110	101	90	82	75	70	65	62	59	53	49	43	38	36	34	31	29	28
PGP-12	3/4"	449	339	279	242	217	200	173	156	143	133	124	117	111	101	92	79	71	66	60	57	54	51
PGP-16	1"	1246	873	708	610	545	496	428	382	347	321	300	282	268	239	217	187	167	152	141	131	123	117
PGP-20	1-1/4"	2006	1442	1189	1037	933	855	746	671	615	571	536	507	482	434	398	347	312	286	266	249	236	224

Table 5*																							
Maximum Flow Capacity of Parker Parflex Tubing in Cubic Feet per Hour Gas Pressure: 0.5 psi or less; Pressure Drop: 3.0 in. WC (Based on a 0.60 Specific Gravity Gas)																							
Part	Tube	Tubing Length (ft.)																					
No.	Size	5	10	15	20	25	30	40	50	60	70	80	90	100	125	150	200	250	300	350	400	450	500
PGP-6	3/8"	132	92	75	64	57	52	45	40	36	33	31	29	28	25	23	19	17	16	14	14	13	13
PGP-8	1/2"	308	219	179	155	139	127	110	99	90	84	78	74	70	63	57	50	45	41	39	35	33	32
PGP-12	3/4"	500	412	340	296	266	244	212	191	175	162	152	144	137	123	113	98	88	81	75	70	67	63
PGP-16	1"	1500	1046	847	729	649	591	509	453	412	380	355	334	316	281	256	220	196	178	165	154	144	137
PGP-20	1-1/4"	2432	1749	1442	1258	1131	1037	904	813	746	693	650	615	585	526	482	420	378	347	322	302	286	272

Table 6*																							
Maximum Flow Capacity of Parker Parflex Tubing in Cubic Feet per Hour Gas Pressure: 0.5 psi or less; Pressure Drop: 4.0 in. WC (Based on a 0.60 Specific Gravity Gas)																							
Part	Tube	Tubing Length (ft.)																					
No.	Size	5	10	15	20	25	30	40	50	60	70	80	90	100	125	150	200	250	300	350	400	450	500
PGP-6	3/8"	148	103	84	72	64	58	50	44	40	37	35	32	31	28	25	21	19	18	16	15	14	13
PGP-8	1/2"	345	246	201	175	157	143	124	112	102	95	88	84	79	71	65	57	51	46	44	40	38	36
PGP-12	3/4"	601	465	383	333	299	273	238	214	195	181	170	161	153	137	126	109	98	90	83	78	74	70
PGP-16	1"	1714	1199	972	838	747	680	586	523	476	439	410	386	366	326	297	255	228	207	192	179	168	159
PGP-20	1-1/4"	2789	2006	1654	1442	1279	1189	1037	933	855	795	746	705	671	603	553	482	434	398	369	347	328	312

Note: Tables 6 and 7 do not include the effects of pressure drop across the line regulator. If regulator pressure drop exceeds 22" WC across 325-3 or 325-5A regulators, DO NOT USE TABLES 5 and 6. **CONTACT PARKER AT 1-888-FASTMATE.**

\*Table includes losses for four 90 degree bends and two end fittings. To determine flow capacity for tubing runs with additional bends and/or fittings, add the appropriate number of feet to the actual run length using the formula:  $L = 1.3n$ . L = number of feet to be added to actual run length; n = number of additional bends and/or fittings.

**7.1 CSST Tables (Continued)**

**Natural Gas**

**Caution: Locate proper sizing table based on total pressure drop allowed in piping system by local utility for each installation.**

Table 7*																							
Maximum Flow Capacity of Parker Parflex Tubing in Cubic Feet per Hour Gas Pressure: 0.5 psi or less; Pressure Drop: 5.0 in. WC (Based on a 0.60 Specific Gravity Gas)																							
Part	Tube	Tubing Length (ft.)																					
No.	Size	5	10	15	20	25	30	40	50	60	70	80	90	100	125	150	200	250	300	350	400	450	500
PGP-6	3/8"	165	114	92	79	70	64	55	49	44	41	38	36	34	30	28	24	21	19	17	17	16	15
PGP-8	1/2"	383	272	224	194	174	159	138	124	113	105	99	93	89	79	72	63	56	52	48	45	42	41
PGP-12	3/4"	702	518	425	369	331	303	263	236	216	200	187	177	168	151	138	120	107	98	91	85	81	76
PGP-16	1"	1927	1351	1098	947	844	770	664	592	539	498	466	438	415	370	337	291	259	236	218	204	192	182
PGP-20	1-1/4"	3101	2230	1839	1604	1442	1322	1153	1037	951	884	829	784	746	671	615	536	482	442	411	386	364	347

Table 8*																							
Maximum Flow Capacity of Parker Parflex Tubing in Cubic Feet per Hour Gas Pressure: 0.5 psi or less; Pressure Drop: 6.0 in. WC (Based on a 0.60 Specific Gravity Gas)																							
Part	Tube	Tubing Length (ft.)																					
No.	Size	5	10	15	20	25	30	40	50	60	70	80	90	100	125	150	200	250	300	350	400	450	500
PGP-6	3/8"	181	125	101	87	77	70	60	53	48	45	42	39	37	33	30	26	23	21	19	18	17	16
PGP-8	1/2"	420	299	246	214	192	175	152	137	125	116	109	103	98	87	80	70	62	57	53	50	47	45
PGP-12	3/4"	803	571	468	406	364	332	289	259	236	219	205	194	184	165	151	131	117	107	99	93	88	83
PGP-16	1"	2141	1504	1223	1056	942	859	741	662	603	557	521	490	465	415	378	326	291	265	245	229	216	204
PGP-20	1-1/4"	3382	2432	2006	1749	1573	1442	1258	1131	1037	964	904	855	813	731	671	585	526	482	448	420	398	378

Table 9*																							
Maximum Flow Capacity of Parker Parflex Tubing in Cubic Feet per Hour Gas Pressure: 2.0 psig; Pressure Drop: 1.0 psig (Based on a 0.60 Specific Gravity Gas)																							
Part	Tube	Tubing Length (ft.)																					
No.	Size	5	10	15	20	25	30	40	50	60	70	80	90	100	125	150	200	250	300	350	400	450	500
PGP-6	3/8"	389	270	218	187	166	151	129	115	104	96	90	84	80	71	64	55	49	45	41	38	36	34
PGP-8	1/2"	791	568	468	408	366	336	293	263	241	224	210	198	189	170	155	135	122	112	104	97	92	87
PGP-12	3/4"	1468	1063	881	770	695	638	558	503	462	430	404	383	365	329	302	264	238	219	204	191	181	172
PGP-16	1"	4253	2980	2421	2088	1863	1696	1464	1305	1189	1098	1026	965	915	816	743	641	572	521	481	449	423	401
PGP-20	1-1/4"	7004	5037	4154	3623	3258	2987	2605	2343	2148	1932	1874	1771	1685	1515	1389	1212	1090	999	928	871	824	783

**7.1 CSST Tables (Continued)**

**Natural Gas**

**Caution: Locate proper sizing table based on total pressure drop allowed in piping system by local utility for each installation.**

Table 10*																							
Maximum Flow Capacity of Parker Parflex Tubing in Cubic Feet per Hour Gas Pressure: 2.0 psig; Pressure Drop: 1.5 psig (Based on a 0.60 Specific Gravity Gas)																							
Part	Tube	Tubing Length (ft.)																					
No.	Size	5	10	15	20	25	30	40	50	60	70	80	90	100	125	150	200	250	300	350	400	450	500
PGP-6	3/8"	483	334	269	231	205	186	160	142	129	119	111	104	98	87	79	68	60	55	51	47	44	42
PGP-8	1/2"	1005	715	586	509	456	417	362	325	297	275	257	243	231	207	189	164	147	135	125	117	110	105
PGP-12	3/4"	1853	1331	1097	956	860	788	687	618	566	526	494	467	444	399	366	319	287	263	244	229	217	206
PGP-16	1"	5326	3766	3075	2663	2382	2174	1883	1684	1537	1423	1331	1255	1191	1065	972	842	753	688	637	595	561	533
PGP-20	1-1/4"	8494	6109	5037	4393	3951	3623	3159	2841	2605	2343	2272	2148	2043	1838	1685	1469	1321	1212	1126	1057	999	950

Table 11*																							
Maximum Flow Capacity of Parker Parflex Tubing in Cubic Feet per Hour Gas Pressure: 5.0 psig; Pressure Drop: 3.5 psig (Based on a 0.60 Specific Gravity Gas)																							
Part	Tube	Tubing Length (ft.)																					
No.	Size	5	10	15	20	25	30	40	50	60	70	80	90	100	125	150	200	250	300	350	400	450	500
PGP-6	3/8"	756	524	423	363	323	293	252	224	203	187	174	164	155	138	125	107	96	87	80	74	70	66
PGP-8	1/2"	1540	1102	907	789	709	649	565	507	465	431	405	382	363	326	299	260	234	214	199	186	176	167
PGP-12	3/4"	2817	2034	1681	1469	1322	1214	1060	955	876	815	765	724	689	621	570	498	448	411	383	359	340	323
PGP-16	1"	8755	6143	4993	4310	3846	3504	3024	2698	2458	2272	2122	1998	1893	1689	1539	1329	1185	1080	996	932	878	832
PGP-20	1-1/4"	12709	9140	7537	6573	5911	5420	4727	4251	3898	3623	3400	3215	3057	2750	2521	2199	1977	1813	1685	1581	1495	1422

Note: Table 8 does include the effects of pressure drop across the line regulator. If regulator pressure drop exceeds 1 psig across 325-3 or 325-5A regulators, DO NOT USE THIS TABLE. **CONTACT PARKER AT 1-888-FASTMATE.**

\*Table includes losses for four 90 degree bends and two end fittings. To determine flow capacity for tubing runs with additional bends and/or fittings, add the appropriate number of feet to the actual run length using the formula:  $L = 1.3n$ . L = number of feet to be added to actual run length; n = number of additional bends and/or fittings.

**7.1 CSST Tables (Continued)**

**Propane**

**Caution: Locate proper sizing table based on total pressure drop allowed in piping system by local utility for each installation.**

Table 12*																							
Maximum Flow Capacity of Parker Parflex Tubing in Cubic Feet per Hour Gas Pressure: 11.0 in. WC; Pressure Drop: 0.5 in. WC (Based on a 1.52 Specific Gravity LP Gas)																							
Part	Tube	Tubing Length (ft.)																					
No.	Size	5	10	15	20	25	30	40	50	60	70	80	90	100	125	150	200	250	300	350	400	450	500
PGP-6	3/8"	82	58	47	41	37	33	29	26	24	22	20	19	18	16	15	13	12	11	10	9	9	8
PGP-8	1/2"	197	144	120	106	95	88	77	70	64	60	57	54	51	46	43	37	34	31	29	27	26	25
PGP-12	3/4"	378	271	223	194	174	160	139	125	115	106	100	94	90	81	74	64	58	53	49	46	44	41
PGP-16	1"	996	701	570	492	439	400	346	308	281	260	243	229	217	193	176	152	136	124	114	107	101	95
PGP-20	1-1/4"	1651	1188	979	854	768	704	615	553	506	470	441	417	397	357	326	285	256	236	218	205	194	185

Table 15*																							
Maximum Flow Capacity of Parker Parflex Tubing in Cubic Feet per Hour Gas Pressure: 13.0 - 14.0 in. WC (1/2 psig); Pressure Drop: 2.5 in. WC (Based on a 1.52 Specific Gravity LP Gas)																							
Part	Tube	Tubing Length (ft.)																					
No.	Size	5	10	15	20	25	30	40	50	60	70	80	90	100	125	150	200	250	300	350	400	450	500
PGP-6	3/8"	167	121	101	88	80	74	65	58	54	50	47	45	43	39	36	32	29	27	25	24	23	22
PGP-8	1/2"	430	311	257	225	202	186	162	146	134	125	117	111	106	95	88	77	69	63	59	55	52	50
PGP-12	3/4"	843	602	495	430	386	353	307	276	253	234	220	207	197	177	162	141	126	116	107	101	95	90
PGP-16	1"	2292	1636	1340	1161	1038	947	817	728	662	610	568	533	503	445	402	341	299	267	243	223	207	193
PGP-20	1-1/4"	3551	2518	2076	1810	1628	1493	1302	1171	1074	997	936	885	842	757	694	606	545	499	463	435	411	391

Table 17*																							
Maximum Flow Capacity of Parker Parflex Tubing in Cubic Feet per Hour Gas Pressure: 2 psig; Pressure Drop: 1.0 psig (Based on a 1.52 Specific Gravity LP Gas)																							
Part	Tube	Tubing Length (ft.)																					
No.	Size	5	10	15	20	25	30	40	50	60	70	80	90	100	125	150	200	250	300	350	400	450	500
PGP-6	3/8"	646	448	361	310	276	250	215	191	173	160	149	140	132	118	107	92	82	74	68	64	60	57
PGP-8	1/2"	1313	943	776	677	608	557	486	436	400	372	349	329	313	282	258	225	202	185	172	161	153	145
PGP-12	3/4"	2437	1765	1462	1279	1153	1059	927	835	767	714	671	635	605	545	501	438	395	363	338	318	301	286
PGP-16	1"	7060	4947	4018	3467	3092	2816	2429	2167	1973	1823	1702	1603	1518	1354	1233	1064	949	864	798	746	702	665
PGP-20	1-1/4"	11153	8021	6615	5769	5188	4756	4148	3731	3420	3076	2984	2820	2683	2412	2212	1930	1736	1591	1478	1387	1312	1247

Note: Table 12 does not include the effects of pressure drop across the line regulator. If regulator pressure drop exceeds 17" WC across 325-3 regulator or 325-5A regulator, DO NOT USE TABLE 11. CONTACT PARKER AT 1-888-FASTMATE.



**7.1 CSST Tables (Continued)**

**Propane**

**Caution: Locate proper sizing table based on total pressure drop allowed in piping system by local utility for each installation.**

Table 18*																							
Maximum Flow Capacity of Parker Parflex Tubing in Cubic Feet per Hour Gas Pressure: 2.0 psig; Pressure Drop: 1.5 psig (Based on a 1.52 Specific Gravity LP Gas)																							
Part No.	Tube Size	Tubing Length (ft.)																					
		5	10	15	20	25	30	40	50	60	70	80	90	100	125	150	200	250	300	350	400	450	500
PGP-6	3/8"	763	528	426	365	324	294	253	224	204	188	175	164	150	138	124	107	94	87	80	74	70	66
PGP-8	1/2"	1588	1130	926	804	720	659	572	513	469	435	406	384	365	327	298	259	232	213	197	185	174	166
PGP-12	3/4"	2927	2104	1733	1511	1359	1247	1086	977	895	831	779	737	701	630	578	504	453	415	386	362	342	325
PGP-16	1"	8267	5799	4716	4071	3631	3303	2854	2548	2322	2146	2001	1888	1787	1596	1454	1255	1119	1019	943	880	829	784
PGP-20	1-1/4"	13526	9728	8021	6995	6291	5769	5030	4524	4148	3731	3618	3420	3253	2927	2683	2339	2104	1930	1793	1683	1591	1513

Table 19*																							
Maximum Flow Capacity of Parker Parflex Tubing in Cubic Feet per Hour Gas Pressure: 5.0 psig; Pressure Drop: 3.5 psig (Based on a 1.52 Specific Gravity LP Gas)																							
Part No.	Tube Size	Tubing Length (ft.)																					
		5	10	15	20	25	30	40	50	60	70	80	90	100	125	150	200	250	300	350	400	450	500
PGP-6	3/8"	1188	826	664	570	509	461	396	352	319	294	275	257	243	216	196	169	150	136	125	117	110	104
PGP-8	1/2"	2417	1731	1423	1239	1113	1019	887	797	730	677	635	600	570	512	469	408	367	336	312	292	276	263
PGP-12	3/4"	4423	3193	2639	2306	2076	1906	1665	1499	1376	1280	1202	1137	1082	974	894	781	703	646	601	564	534	508
PGP-16	1"	13745	9644	7839	6767	6038	5501	4748	4237	3860	3567	3332	3137	2973	2652	2416	2086	1861	1695	1567	1464	1378	1306
PGP-20	1-1/4"	20237	14554	12002	10467	9413	8631	7527	6769	6207	5769	5414	5119	4868	4379	4014	3502	3148	2887	2683	2518	2381	2264

Note: Tables 13 and 14 do not include the effects of pressure drop across the line regulator. If regulator pressure drop exceeds 1 psig across 325-3 regulator or 325-5A regulators, DO NOT USE THESE TABLES. CONTACT PARKER AT 1-888-FASTMATE.



**7.2 Schedule 40 Metallic Pipe Table**

Table 20 Maximum Capacity of Steel IPS Pipe in Cubic Feet per Hour <b>Gas Pressure: 0.5 psig or less; Pressure Drop: 0.5 psig</b> (Based on a 0.60 Specific Gravity Gas)															
Pipe Size (in)	Diameter (in)	10	20	30	40	50	60	70	80	90	100	125	150	175	200
1/4	0.36	43	29	24	20	18	16	15	14	13	12	11	10	9	8
3/8	0.49	95	65	52	45	40	36	33	31	29	27	24	22	20	19
1/2	0.62	175	120	97	82	73	66	61	57	53	50	44	40	37	35
3/4	0.82	360	250	200	170	151	138	125	118	110	103	93	84	77	72
1	1.05	680	465	375	320	285	260	240	220	205	195	175	160	145	135
1-1/4	1.38	1400	950	770	660	580	530	490	460	430	400	360	325	300	280
1-1/2	1.61	2100	1460	1180	990	900	810	750	690	650	620	550	500	460	430
2	2.07	3950	2750	2200	1900	1680	1520	1400	1300	1220	1150	1020	950	850	800
2-1/2	2.47	6300	4350	3520	3000	2650	2400	2250	2050	1950	1850	1650	1500	1370	1280
3	3.07	11000	7700	6250	5300	4750	4300	3900	3700	3450	3250	2950	2650	2450	2280
4	4.03	23000	15800	12800	10900	9700	8800	8100	7500	7200	6700	6000	5500	5000	4600

\* Table reproduced from National Fuel Gas Code NFPA-54.

**AGA** – American Gas Association.

**ANSI Z223.1** – 1992 edition of the National Fuel Gas Code published by American National Standard Institute. Also known as NFPA 54 (National Fire Protection Association, pamphlet 54).

**Appliance** – Any device which utilizes gas as a fuel or raw material to produce light, heat, power, refrigeration or air conditioning.

**Appliance Stubout** – Creates a fixed point on a wall or floor surface for attaching a moveable appliance (with approved flexible gas connector).

**Approved** – Acceptable to the authorities having jurisdiction.

**Authority Having Jurisdiction** – The organization, office or individual responsible for approving equipment, an installation or a procedure.

**Boiler** – An enclosed vessel in which water is heated and circulated, either as hot water or steam, for heating.

**Bonding (Bonded)** – The permanent joining of metallic parts to form an electrically conductive path that will ensure electrical continuity and the capacity to conduct safely any current likely to be imposed.

**BTU** – Abbreviation for British Thermal Unit, the quantity of heat required to raise the temperature of one pound of water one degree Fahrenheit.

**Cfh** – Gas flow rate stated in cubic feet per hour. A Cfh contains between 900 BTU and 1200 BTU. Consult the local gas utility in your area for actual BTU content.

**CSA** – Canadian Standards Association International.

**Capacity, Flow** – As used in this standard, the amount of a specified gas that will flow through a specific length and configuration of tubing, a manifold, a fitting or other component at a specified pressure drop in a fixed period of time.

**Concealed Gas Piping** – Gas piping which when in place in a finished building would require removal of permanent construction to gain access to the piping.

**Connector, Gas Appliance** – A factory fabricated assembly of gas conduit and related fittings designed to convey gaseous fuel and used for making connections between a gas supply piping outlet and the gas to an appliance. It is equipped at each end for attachment to standard taper pipe threads.

**CSST** – Corrugated stainless steel tubing.

**Design Pressure** – The maximum operating pressure permitted by this document as determined by the design procedures applicable to the materials involved.

**Drip Leg** – The container (dirt trap pocket) placed at a low point in a system of piping to collect dirt and condensate and from which it may be removed.

**Equivalent Hydraulic Diameter (EHD)** – A theoretical size which reflects the hydraulic performance of the tubing. It is not a true physical measurement.

**Elevated Pressure System** – A shortened way of stating any pressure over 1/2 psig, but less than 5 psig.

**Exposed Gas Piping** – Gas piping which will be in view in the finished structure.

**FastMate™** – Trade name for Parker patented quick connect gas pipe fittings.

**Fuel Gas** – A commonly distributed gas used for fuel such as natural gas, manufactured gas, undiluted liquefied petroleum gas (vapor phase only), liquefied petroleum gas-air mixtures of these gases (includes propane and butane).

**Furnace** – A self-contained, gas-burning appliance for heating air by transfer of heat of combustion through metal to air, and designed to supply heated air through ducts to spaces remote from or adjacent to the appliance location.

**Inches (" ) WC** – Method of stating pressure measured in inches of water column by a manometer or pressure gauge. Commonly used in the gas industry when the pressure is less than one (1) psig.

1 psig = 28 in. WC, 1/2 psig = 14 in. WC, 1/4 psig = 7 in. WC approximately.

**Joint** – A connection between two lengths of tubing or between a length of tubing and a fitting.

**Joint Compounds** – Non-hardening material used on pipe threads to ensure a seal.

**Listed** – Equipment or materials including a list published by an organization acceptable to the authority having jurisdiction and concerned with product evaluation that maintains periodic inspection of production of listed equipment or materials and whose listing states either that the equipment or material meets appropriate standards or has been tested and found suitable for use in a specified manner.

**Lockup Pressure Regulator** – The system pressure immediately downstream of the regulator at which the regulator valve will completely close (leak tight) under no-flow conditions to prevent the downstream pressure from exceeding a predetermined level.

**Manifold** – A pipe or fitting to which a number of branch lines are connected.

**Maximum Operating Pressure** – The maximum pressure existing in a piping system during a normal annual operating cycle.

**Meter** – An instrument installed to measure the volume of gas delivered through a piping system.

**Meter Stubout** – Creates a fixed point through a wall for connection to gas meter.

**OPD** – Over-pressure protection device. To comply with the ANSI Z21.80 standard for line pressure regulators, installations exceeding 2 psi nominal require a tested and approved over-pressure protection device for use with the regulator.

**Parflex®** – Trade name for Parker Gas Piping.

**Parflex Piping System** – An assembly of corrugated stainless steel tubing and tubing connection fittings intended for field assembly and installation in residential and commercial buildings to distribute fuel gas to gas utilization equipment within the building. The piping system may also include a gas pressure regulator(s), a shut-off valve(s), tube shielding devices, distribution manifold(s), and other approved devices or components.

**Pressure** – Unless otherwise stated, is expressed in pounds per square inch above atmospheric pressure, i.e., gauge pressure (psig).

**Pressure Drop** – The loss in static pressure of flowing fuel gas due to friction or other flow resistance in tubing, fittings, valves, regulators, or other devices in the piping system.

**PSIG (psig)** – Pounds per square inch gauge. The pressure as read from a measurement gauge or device. Gauge pressure is pressure above atmospheric pressure.

**Purge** – To displace the original air, or gas, or a mixture of gas and air in a gas conduit with a new air/gas mixture.

**Qualified Installer** – Any individual, firm, corporation or company which either in person or through a representative is engaged in and is responsible for the installation or replacement of building gas piping systems, who is experienced in such work, familiar with all precautions required, and who has complied with all the requirements of the authority having jurisdiction.

**Quick Disconnect Device** – A hand-operated device which provides a means for connecting and disconnecting an appliance or an appliance connector to a gas supply and which is equipped with an automatic means to shut off the gas supply when the device is disconnected.

**Regulator, Pressure** – A device placed in a gas line for reducing, controlling, and maintaining the pressure in that portion of the piping system downstream of the device.

**Regulator, Vent** – The opening in the atmospheric side of the regulator housing permitting the in and out movement of air to compensate for the movement of the regulator diaphragm.

**Shielding Device** – A component of the piping system used to protect the installed corrugated tubing from accidental puncture by nails, screws or similar hardware at concealed tubing support points.

**Specific Gravity** – As applied to gas, the ratio of the weight of a given volume to that of the same volume of air, both measured under the same conditions.

**Striker Plate** – A special type of shielding device used when concealed tubing is run through wall studs, floor and ceiling joists or other structural members where tubing movement is restricted.

**Valve Shut-off** – A device used in piping to control the gas supply to any section of the piping system or to an appliance. It is located in the piping system and is readily accessible and operable by the consumer to shut off individual equipment.

**Water Heater** – An appliance for supplying hot water for domestic or commercial purposes other than for space heating.

## Offer of Sale

This Offer of Sale extends to Parker Hannifin Corporation's Parflex Division Flexible Gas Piping products ("Products") only. The products described in this offer are hereby offered for sale to wholesalers (individually "Wholesaler") at prices established by Parker Hannifin ("Seller"). This offer and its acceptance by any customer ("Buyer") shall be governed by all of the following Terms and Conditions. Buyer's order for any item described in its document, when communicated to Parker Hannifin Corporation, its subsidiary or an authorized agent verbally or in writing, shall constitute acceptance of this offer.

**1. Terms and Conditions of Sale:** All descriptions, quotations, proposals, offers, acknowledgments, acceptances and sales of Seller's products are subject to and shall be governed exclusively by the terms and conditions stated herein. Buyer's acceptance of any offer to sell is limited to these terms and conditions. Any terms or conditions in addition to, or inconsistent with those stated herein, proposed by Buyer in any acceptance of an offer by Seller, are hereby objected to. No such additional, different or inconsistent terms and conditions shall become part of the contract between Buyer and Seller unless expressly accepted in writing by Seller. Seller's acceptance of any offer to purchase by Buyer is expressly conditional upon Buyer's assent to all the terms and conditions stated herein, including any terms in addition to, or inconsistent with those contained in Buyer's offer. Acceptance of Seller's Products shall in all events constitute such assent.

**2. Payment:** Credit terms are 2% 10<sup>th</sup> prox. Net 30 days from the date of delivery of the items purchased hereunder. Any claims by Buyer for omissions or shortages in a shipment shall be waived unless Seller receives notice thereof within 30 days after Buyer's receipt of the shipment.

**3. Delivery:** Wholesaler orders for single shipment of \$ 3000 or more of standard "Parflex" brand Product will be shipped F.O.B. destination point in the continental U.S unless otherwise provided on the face hereof. All other order delivery shall be made F.O.B. Seller's plant. Regardless of the method of delivery, however, risk of loss shall pass to Buyer upon Seller's delivery to a carrier. Any delivery dates shown are approximate only and Seller shall have no liability for any delays in delivery.

**4. Minimum Order:** Seller reserves the right to increase order quantities to comply with the \$ 50.00 minimum billing and to meet box quantities.

**5. Return Policy:** All Product returns require prior approval by Seller and issuance of a Seller authorization to return (ATR). The returned goods must match the part numbers and quantities on the ATR and the shipment must be clearly tagged with the ATR number. All product returned must be listed in the current Parflex price schedule and must be in resalable condition. Returned product that does not meet the criteria established within this document will be returned FREIGHT COLLECT or scrapped at the discretion of Buyer. Credit will be issued for the agreed upon original purchase price less a 25% restock fee. Stock adjustment returns, without restocking fee, will be allowed once per calendar year for return of standard Products listed in the current price list. The dollar value of the stock adjustment return is limited to 10% of prior 12-month purchases. Credit for the stock adjustment return is contingent upon shipment of product per Buyer's stock-adjustment purchase for an amount that at least equals dollar value of the return. Prepaid freight will not be allowed on the stock replacement purchase order.

**6. Warranty:** Seller warrants its Products sold by its Parflex Division to be free from defects in material or workmanship for a period of three (3) years from date of shipment by Seller or two (2) years from the date of installation by contractor, whichever ever comes first. Seller will repair or replace any Product that is discovered to contain such defects within such period or refund the purchase price paid. This warranty shall be void as to any Product or part of any Product which has been installed, altered, repaired or misused in a manner which, in Seller's sole discretion, adversely affects the reliability or performance of the Product. For purposes of this provision, any installation which is not performed in strict compliance with local plumbing and building codes by an installer who has been trained in the assembly and installation of the Products in accordance with the Guidelines established by the American Gas Association, shall be deemed to adversely affect the reliability or performance of the product and shall void all Warranties. THIS LIMITED WARRANTY IS THE SOLE WARRANTY MADE BY SELLER RELATIVE TO THE PRODUCTS. ALL OTHER WARRANTIES, INCLUDING BUT NOT LIMITED TO, MERCHANTABILITY AND FITNESS FOR PARTICULAR PURPOSE, WHETHER EXPRESS, IMPLIED, OR ARISING BY OPERATION OF LAW, TRADE USAGE OR COURSE OF DEALING ARE HEREBY DISCLAIMED. THIS WARRANTY DOES NOT EXTEND TO PRODUCTS BUILT OR ACQUIRED TO BUYER'S DESIGN OR SPECIFICATIONS. THIS WARRANTY WILL BE GOOD FOR THREE YEARS FROM DATE OF SHIPMENT.

**7. Limitation Of Remedy:** SELLER'S LIABILITY ARISING FROM OR IN ANY WAY CONNECTED WITH THE ITEMS SOLD OR THIS CONTRACT SHALL BE LIMITED EXCLUSIVELY TO REPAIR OR REPLACEMENT OF THE ITEMS SOLD OR REFUND OF THE PURCHASE PRICE PAID BY BUYER, AT SELLER'S SOLE OPTION. IN NO EVENT SHALL SELLER BE LIABLE FOR ANY INCIDENTAL, CONSEQUENTIAL OR SPECIAL DAMAGES OF ANY KIND OR NATURE WHATSOEVER, INCLUDING BUT NOT LIMITED TO LOST PROFITS ARISING FROM OR IN ANY WAY CONNECTED WITH THIS AGREEMENT OR ITEMS SOLD HEREUNDER, WHETHER ALLEGED

TO ARISE FROM BREACH OF CONTRACT, EXPRESS OR IMPLIED WARRANTY, OR IN TORT, INCLUDING WITHOUT LIMITATION, NEGLIGENCE, FAILURE TO WARN OR STRICT LIABILITY.

**8. Obligations of Wholesaler:** To assure that Wholesaler and its employees are familiar with the proper methods of handling, installation and use of the Products, Wholesaler shall cause its employees to undergo training and testing programs by or under the direction of Seller and/or its agents. Thereafter, Wholesaler shall require each of its customers of the Products to complete a qualification application and shall approve the sale of Products only to those contractors, installers and other persons who have successfully demonstrated adequate knowledge of the Product, its installation techniques and local building codes. Any violation of the provisions of this Section shall automatically void any express or implied warranty provided by Seller with respect to any Product that may directly or indirectly benefit Wholesaler.

**9. Taxes:** Unless otherwise indicated on the face hereof, all prices and charges are exclusive of excise, sales, use, property, occupational or like taxes which may be imposed by any taxing authority upon the manufacture, sale or delivery of the items sold hereunder. If any such taxes must be paid by Seller or if Seller is liable for the collection of such tax, the amount thereof shall be in addition to the amounts for the items sold. Buyer agrees to pay all such taxes or to reimburse Seller therefore upon receipt of its invoice. If Buyer claims exemption from any sales, use or other tax imposed by any taxing authority, Buyer shall save Seller harmless from and against any such tax, together with any interest or penalties thereon which may be assessed if the items are held to be taxable.

**10. Force Majeure:** Seller does not assume the risk of and shall not be liable for delay or failure to perform any of Seller's obligations by reason of circumstances beyond the reasonable control of Seller [hereinafter "events of Force Majeure"]. Events of Force Majeure shall include without limitation, accidents, acts of God, strikes or labor disputes, acts, laws, rules or regulations of any government or government agency, fires, floods, delays or failures in delivery of carriers or suppliers, shortages of materials and any other cause beyond Seller's control.

**11. Entire Agreement/Governing Law:** The terms and conditions set forth herein, together with any amendments, modifications and any different terms or conditions expressly accepted by Seller in writing, shall constitute the entire Agreement concerning the items sold, and there are no oral or other representations or agreements which pertain thereto. This Agreement shall be governed in all respects by the law of the State of Ohio. No actions arising out of the sale of the items sold hereunder or this Agreement may be brought by either party more than two (2) years after the cause of action accrues.

**12. Indemnity For Infringement of Intellectual Property Rights:** Seller shall have no liability for infringement of any patents, trademarks, copyrights, trade dress, trade secrets or similar rights except as provided in this Part 10. Concerning the design and manufacture of the Products and the marketing of same by Seller, Seller will defend and indemnify Buyer against allegations of infringement of U.S. patents, U.S. trademarks, copyrights, trade dress and trade secrets (hereinafter "Intellectual Property Rights"). Seller will defend at its expense and will pay the cost of any settlement or damages awarded in an action brought against Buyer based on an allegation that an item sold pursuant to this contract infringes the Intellectual Property Rights of a third party. Seller's obligation to defend and indemnify Buyer is contingent on Buyer notifying Seller within ten (10) days after Buyer becomes aware of such allegations of infringement, and Seller having sole control over the defense of any allegations or actions including all negotiations for settlement or compromise. If an item sold hereunder is subject to a claim that it infringes the Intellectual Property Rights of a third party, Seller may, at its sole expense and option, procure for Buyer the right to continue using said item, replace or modify said item so as to make it noninfringing, or offer to accept return of said item and return the purchase price less a reasonable allowance for depreciation. Notwithstanding the foregoing, Seller shall have no liability for claims of infringement based on information provided by Buyer, or directed to items delivered hereunder for which the designs are specified in whole or part by Buyer, or infringements resulting from the modification, combination or use in a system of any item sold hereunder. The foregoing provisions of this Part 10 shall constitute Seller's sole and exclusive liability and Buyer's sole and exclusive remedy for infringement of Intellectual Property Rights.

If a claim is based on information provided by Buyer or if the design for an item delivered hereunder is specified in whole or in part by Buyer, Buyer shall defend and indemnify Seller for all costs, expenses or judgments resulting from any claim that such item infringes any patent, trademark, copyright, trade dress, trade secret or any similar right.

# **Parflex<sup>®</sup>**

**Flexible Gas Piping System**



**Parker Hannifin Corp.**  
1300 North Freedom Street  
Ravenna, OH 44266  
888-327-8628  
(888-FastMate)  
[www.parflexsystem.com](http://www.parflexsystem.com)

4660-PGP2T



Circle the correct answer

1. The design, methods and installation procedures of the Parflex system must comply with:
  - A. International Plumbing Code
  - B. Local Building Codes
  - C. CSA
2. When Local Codes do not exist, which authority takes precedence?
  - A. CSA
  - B. Master plumber on job site
  - C. The Parflex System Design and Installation Guide
3. What must be determined before sizing a gas pipe installation?
  - A. System Pressure
  - B. Location of appliances
  - C. Loads of appliances
  - D. All of the Above
4. All Parflex systems must be installed by a trained and qualified installer.  
True      False
5. The FastMate™ quick connect fitting can be interchanged with fittings manufactured by other firms.  
True      False
6. Parflex can be used in combination with black pipe using approved threaded couplings.  
True      False
7. The maximum working pressure of the Parflex System is:
  - A. 50 PSI
  - B. 5 PSI
  - C. 2 PSI
8. The yellow jacket should be stripped 1 ft. each side of a fire wall, duct or plenum.  
True    False
9. Clearance holes for routing the Parflex tubing are to be the same size of the pipe.  
True    False
10. Parflex Tubing must be protected from physical damage at support points and locations where the tubing passes through joists, studs, clamps and floor plates.  
True    False
11. At support points where the tubing passes less than 2 inches away from the edge of a stud, joist or plate in a concealed wall space, a full or half striker plate should be used.  
True    False
12. Protection is required when the tubing is constrained, concealed and 3 inches or less from a potential nail threat.  
True    False

- 13. Moveable appliances (range, dryer) must be connected to a rigidly mounted flange fitting using only approved flexible appliance connectors.  
True False
- 14. If there is no local requirement, the minimum test pressure should be one and a half times working pressure but not less than 3 psi.  
True False
- 15. Pressure testing must be performed during rough construction before interior walls are finished.  
True False
- 16. The Parflex Design & Installation Manual advises, along with most local codes, an additional pressure or leakage test be performed after construction is completed and interior walls are finished.  
True False
- 17. For best results when cutting the tubing, use maximum roller pressure for a faster cut.  
True False
- 18. Copper tubing cutters can be used if Parflex cutters are unavailable.  
True False
- 19. What is the correct insertion depth for the tubing into the FastMate Fitting?
  - A. 2 Corrugations
  - B. It doesn't matter
  - C. 1 Corrugation
- 20. The nut should be removed from the fitting body prior to installation.  
True False

---

---

**PLEASE PRINT CLEARLY**

Any illegible information could delay receipt of a permanent certification card.

**Name:** \_\_\_\_\_

**Date:** \_\_\_\_\_

**Company:** \_\_\_\_\_

**Address:** \_\_\_\_\_

**City/State/Zip:** \_\_\_\_\_

**Phone Number:** \_\_\_\_\_

**Parflex**<sup>®</sup> **Temporary Certificate**  
Flexible Gas Piping System Authorized to purchase and install Parflex System Products

**Name:** \_\_\_\_\_

**Company:** \_\_\_\_\_

**Instructor:** \_\_\_\_\_

**Valid for 90 Days from this Date:** \_\_\_\_\_

I am familiar with the manufacturer's guidelines for installation of this system, the assembly of the mechanical fittings and the placement of necessary protective devices.

**Applicant's Signature:** \_\_\_\_\_

**Instructor's Name:** \_\_\_\_\_

**Manufacturer's Rep:** \_\_\_\_\_