



## Compressors MT/Z series

Danfoss Compressors - Commercial reciprocating



### Constant innovation, constant progress

Throughout the last 50 years Danfoss Compressors has built a strong position as a global leader in the refrigeration and air conditioning industry. By constantly listening to the needs of our customers and the daily users of our products, we continue to develop innovative solutions that are energy-efficient and environmentally responsible.

With the most complete range of products for virtually any refrigeration or air-conditioning application, we are proud to offer solutions that are famous and trusted by customers all over the world for their reliability, efficiency and high quality.

### Extensive product and application range

Our product range covers all common HC, HFC and HCFC refrigerants. Customers can choose from small, direct current hermetic compressors for mobile applications to large scroll compressors for commercial air conditioning or industrial applications.

### Pushing technology further

We were the first to market with R134a. We can also cater for needs with energy optimised, including models with variable speed and monitoring as well as models developed for the solar energy industry. Proof of our constant focus on providing value through maximum efficiency, environmental safety and low noise levels.

- ⚠ Note:
- For commercial range of compressors refer to Application guidelines
  - Selection and Application guideline manuals available for MTZ & NTZ
  - Contact Danfoss product specialist for guideline manuals

# MTZ Reciprocating Compressor Quick ordering guide

Model Number	Ordering Code		Nom HP	Cylinder No	Swept Volume cm3/rev	Displacement m3/h @ 2900	Oil charge Litres	Oil Sight Glass	Oil Type	Rotolock (Thread)		Rotolock (Pipe/Type)		Net weight kg	Comments
	Code 4 3 Phase	Code 5 1 Phase								Suction	Discharge	Suction	Discharge		
MTZ018	MTZ18-4VI	MTZ18-5VI	1.5	1	30	5.3	0.95	Yes	160PZ	1"	1"	1/2" (V06)	3/8" (V01)	21	
MTZ022	MTZ22-4VI	MTZ22-5VI	1.75	1	38	6.6	0.95	Yes	160PZ	1"	1"	1/2" (V06)	3/8" (V01)	21	
MTZ028	MTZ28-4VI	MTZ28-5VI	2	1	48	8.4	0.95	Yes	160PZ	1"	1"	1/2" (V06)	3/8" (V01)	23	
MTZ032	MTZ32-4VI	MTZ32-5VI	2.5	1	54	9.4	0.95	Yes	160PZ	1 1/4"	1"	5/8" (V09)	1/2" (V06)	25	
MTZ036	MTZ36-4VI	MTZ36-5VI	3	1	60	10.5	0.95	Yes	160PZ	1 1/4"	1"	5/8" (V09)	1/2" (V06)	26	
MTZ040	MTZ40-4VI	-	3.5	1	68	11.8	0.95	Yes	160PZ	-	-	-	-	-	
MTZ044	MTZ44-4VI	-	3.75	2	76	13.3	1.8	Yes	160PZ	1 3/4"	1 1/4"	7/8" (V07)	3/4" (V04)	35	
MTZ045	MTZ45-4VI	-	3.75	2	76	13.3	1.8	Yes	160PZ	1 3/4"	1 1/4"	7/8" (V07)	3/4" (V04)	37	Use MTZ44-4VI
MTZ050	MTZ50-4VI	-	4	2	86	14.9	1.8	Yes	160PZ	1 3/4"	1 1/4"	7/8" (V07)	3/4" (V04)	35	
MTZ051	MTZ51-4VI	-	4	2	86	14.9	1.8	Yes	160PZ	1 3/4"	1 1/4"	7/8" (V07)	3/4" (V04)	37	Use MTZ50-4VI
MTZ056	MTZ56-4VI	-	4.5	2	96	16.7	1.8	Yes	160PZ	1 3/4"	1 1/4"	7/8" (V07)	3/4" (V04)	37	
MTZ057	MTZ57-4VI	-	4.5	2	96	16.7	1.8	Yes	160PZ	1 3/4"	1 1/4"	7/8" (V07)	3/4" (V04)	39	Use MTZ56-4VI
MTZ064	MTZ64-4VI	-	5.5	2	108	18.7	1.8	Yes	160PZ	1 3/4"	1 1/4"	7/8" (V07)	3/4" (V04)	37	
MTZ065	MTZ65-4VI	-	5.5	2	108	18.7	1.8	Yes	160PZ	1 3/4"	1 1/4"	7/8" (V07)	3/4" (V04)	39	Use MTZ64-4VI
MTZ072	MTZ72-4VI	-	6	2	121	21	1.8	Yes	160PZ	1 3/4"	1 1/4"	7/8" (V07)	3/4" (V04)	40	
MTZ073	MTZ73-4VI	-	6	2	121	21	1.8	Yes	160PZ	1 3/4"	1 1/4"	7/8" (V07)	3/4" (V04)	41	Use MTZ72-4VI
MTZ080	MTZ80-4VI	-	6.5	2	136	23.6	1.8	Yes	160PZ	1 3/4"	1 1/4"	1 1/8" (V02)	3/4" (V04)	40	
MTZ081	MTZ81-4VI	-	6.5	2	136	23.6	1.8	Yes	160PZ	1 3/4"	1 1/4"	1 1/8" (V02)	3/4" (V04)	41	Use MTZ80-4VI
MTZ100	MTZ100-4VI	-	8.5	4	171	29.8	3.9	Yes	160PZ	1 3/4"	1 1/4"	1 1/8" (V02)	3/4" (V04)	60	
MTZ125	MTZ125-4VI	-	10	4	215	37.5	3.9	Yes	160PZ	1 3/4"	1 1/4"	1 1/8" (V02)	3/4" (V04)	64	
MTZ144	MTZ144-4VI	-	12	4	242	42.1	3.9	Yes	160PZ	1 3/4"	1 1/4"	1 1/8" (V02)	3/4" (V04)	67	
MTZ160	MTZ160-4VI	-	13.5	4	272	47.3	3.9	Yes	160PZ	1 3/4"	1 1/4"	1 1/8" (V02)	3/4" (V04)	69	

Crankcase Heater	
Code	
PTC 35 Watt	120Z0459
Terminal Cover & Clamp	
Code	
MTZ 18-45	8156134
MTZ 50-160	8156135

Oil 160PZ (POE)	
Code	
1 Litre	7754019
2 Litre	7754020
Oil 160P (Mineral)	
Code	
2 Litre	7754001
5 Litre	7754002

Rubber Mounting Kits	
Code	
MTZ 18-81	8156001
MTZ 100-125	8156007
MTZ 144-160	8156007
Oil Sight Glass Incl. Gasket	
Code	
1-2-4 Cylinder/VE	8156019

Rotolock Service Valve:	
Code	
V01	8168027
V02	8168028
V04	8168029
V06	8168031
V07	8168032

Note: For additional spares see page 267.

## 1 cylinder

D : 225 mm  
H : 333/358 mm  
H1: 263 mm  
H2: 68 mm

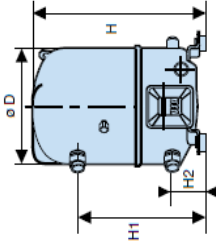

## 2 cylinders

D : 288 mm  
H : 415 mm  
H1: 266 mm  
H2: 75 mm

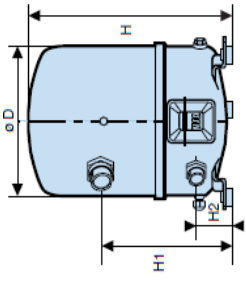

## 4 cylinders

D : 352 mm  
H : 519/540 mm  
H1: 233 mm  
H2: 125 mm

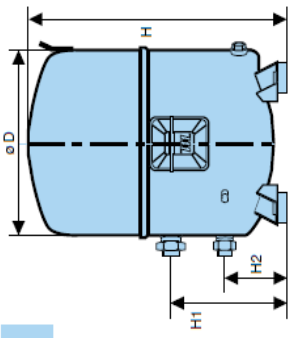

# Reciprocating compressors – Commercial

## Performance data - NTZ, MT and MTZ

NTZ R404A / R507A	Model	To	-45			-40		-35		-30		-25		-20		-15		-10	
		Tc	Qo	Pe	Qo	Pe	Qo	Pe	Qo	Pe	Qo	Pe	Qo	Pe	Qo	Pe	Qo	Pe	
	NTZ048	45	190	0.35	420	0.59	710	0.84	1 240	1.09	1 700	1.34	2 240	1.57	2 860	1.79	3 570	1.99	
NTZ068	45	520	1.02	870	1.28	1 290	1.54	2 110	1.81	2 785	2.09	3 570	2.38	4 490	2.68	5 540	2.99		
NTZ096	45	-	-	910	1.29	1 420	1.67	2 430	2.09	3 360	2.53	4 510	2.99	5 900	3.47	7 550	3.97		
NTZ108	45	-	-	1 120	1.57	1 770	2.03	3 010	2.49	4 080	2.95	5 340	3.40	6 800	3.85	8 530	4.29		
NTZ136	45	-	-	1 570	2.27	2 360	2.86	3 890	3.47	5 200	4.08	6 750	4.69	8 570	5.29	10 710	5.87		
NTZ215	45	1 190	2.31	2 240	3.17	3 540	4.08	5 970	5.01	8 030	5.94	10 440	6.86	13 220	7.72	16 420	8.52		
NTZ271	45	2 120	3.57	3 470	4.61	5 140	5.66	8 380	6.73	11 050	7.81	14 190	8.90	17 840	10.00	22 040	11.10		
NTZ430	45	2 370	4.61	4 480	6.33	7 080	8.15	11 930	10.02	16 060	11.89	20 880	13.71	26 450	15.44	32 840	17.04		
NTZ542	45	4 240	7.14	6 940	9.21	10 290	11.32	16 760	13.46	22 110	15.62	28 380	17.80	35 670	19.99	44 080	22.20		

Legend: To: Evaporating temperature in °C      Qo: Cooling capacity in W      Superheat = 10K; Subcooling = 0 K      Voltage: 400 V / 3 / 50 Hz  
 Tc: Condensing temperature in °C      Pe: Power input in kW      Suction temp. = 20°C; Subcooling = 0 K

MT R22	Model	To	-25		-20		-15		-10		-5		0		5		10		15	
		Tc	Qo	Pe	Qo	Pe	Qo	Pe	Qo	Pe	Qo	Pe	Qo	Pe	Qo	Pe	Qo	Pe	Qo	Pe
	MT018	45	570	0.64	890	0.76	1 300	0.88	1 810	1.00	2 450	1.10	3 220	1.19	4 150	1.26	5 260	1.31	6 550	1.33
MT022	45	740	0.77	1 280	0.95	1 920	1.12	2 670	1.29	3 540	1.44	4 560	1.56	5 720	1.66	7 040	1.73	8 550	1.76	
MT028	45	1 460	1.22	2 190	1.43	3 030	1.63	4 000	1.81	5 090	1.98	6 330	2.11	7 720	2.20	9 280	2.25	11 000	2.24	
MT032	45	1 550	1.46	2 310	1.68	3 190	1.90	4 230	2.11	5 440	2.31	6 830	2.47	8 420	2.60	10 200	2.69	12 300	2.74	
MT036	45	1 960	1.68	2 890	1.90	3 950	2.13	5 150	2.35	6 500	2.56	8 020	2.76	9 710	2.93	11 600	3.07	13 700	3.17	
MT040	45	2 050	1.77	3 080	2.08	4 260	2.39	5 590	2.67	7 090	2.93	8 780	3.15	10 700	3.32	12 800	3.42	15 100	3.45	
MT044	45	1 920	1.70	2 760	1.97	3 850	2.22	5 210	2.46	6 890	2.68	8 880	2.88	11 200	3.07	14 000	3.23	17 100	3.38	
MT050	45	2 170	1.93	3 300	2.31	4 660	2.65	6 290	2.94	8 210	3.20	10 500	3.42	13 000	3.61	16 000	3.77	19 400	3.92	
MT056	45	2 680	2.20	3 770	2.55	5 170	2.88	6 910	3.18	9 020	3.46	11 500	3.72	14 500	3.96	17 900	4.18	21 900	4.38	
MT064	45	3 140	2.40	4 580	2.85	6 290	3.27	8 310	3.64	10 700	3.98	13 400	4.27	16 600	4.53	20 200	4.76	24 300	4.94	
MT072	45	3 240	2.61	4 950	3.20	6 960	3.72	9 340	4.19	12 100	4.60	15 300	4.96	19 000	5.27	23 300	5.54	28 100	5.78	
MT080	45	4 230	3.32	6 180	3.89	8 450	4.41	11 100	4.89	14 200	5.33	17 700	5.72	21 700	6.09	26 300	6.42	31 500	6.72	
MT100	45	4 570	4.06	6 650	4.66	9 150	5.25	12 100	5.79	15 700	6.27	19 900	6.66	24 700	6.94	30 400	7.09	36 800	7.08	
MT125	45	6 690	5.48	9 360	6.17	12 500	6.87	16 400	7.55	20 800	8.18	26 100	8.75	32 200	9.24	39 300	9.63	47 400	9.88	
MT144	45	7 700	6.16	10 700	6.94	14 200	7.71	18 500	8.47	23 600	9.17	29 600	9.81	36 600	10.36	44 700	10.80	54 000	11.09	
MT160	45	8 660	6.93	11 900	7.79	15 800	8.65	20 600	9.49	26 200	10.28	32 800	11.00	40 500	11.61	49 500	12.10	59 800	12.44	
MTM200	45	9 140	8.12	13 300	9.32	18 300	10.49	24 300	11.58	31 400	12.54	39 700	13.32	49 500	13.89	60 700	14.19	73 600	14.17	
MTM250	45	13 400	10.95	18 700	12.35	25 100	13.74	32 700	15.09	41 700	16.36	52 200	17.51	64 500	18.49	78 600	19.25	94 800	19.77	
MTM288	45	15 400	12.32	21 300	13.87	28 500	15.42	37 000	16.93	47 200	18.35	59 200	19.63	73 200	20.72	89 400	21.59	108 000	22.18	
MTM320	45	17 300	13.86	23 800	15.58	31 700	17.30	41 100	18.98	52 300	20.57	65 600	22.00	81 000	23.23	98 900	24.20	119 500	24.88	

MTZ R407C	Model	To	-15		-10		-5		0		5		10		15	
		Tc	Qo	Pe	Qo	Pe	Qo	Pe	Qo	Pe	Qo	Pe	Qo	Pe	Qo	Pe
	MTZ018	45	1 180	0.82	1 750	0.94	2 430	1.04	3 240	1.13	4 180	1.20	5 270	1.25	6 530	1.30
MTZ022	45	1 770	1.07	2 490	1.24	3 330	1.39	4 320	1.50	5 460	1.60	6 790	1.67	8 310	1.73	
MTZ028	45	2 160	1.30	3 110	1.52	4 220	1.72	5 520	1.89	7 030	2.03	8 770	2.13	10 800	2.21	
MTZ032	45	2 710	1.50	3 740	1.75	4 940	1.95	6 330	2.12	7 940	2.27	9 800	2.38	11 900	2.48	
MTZ036	45	3 270	1.81	4 400	2.10	5 710	2.36	7 200	2.57	8 920	2.73	10 900	2.86	13 100	2.95	
MTZ040	45	3 890	2.18	5 150	2.48	6 610	2.74	8 290	2.98	10 200	3.18	12 400	3.35	15 000	3.48	
MTZ044	45	3 570	1.97	4 920	2.28	6 590	2.54	8 610	2.76	11 000	2.94	13 800	3.10	17 100	3.24	
MTZ050	45	4 200	2.34	5 780	2.70	7 650	3.00	9 860	3.24	12 500	3.45	15 500	3.61	19 000	3.75	
MTZ056	45	4 540	2.50	6 310	2.90	8 440	3.24	11 000	3.53	13 900	3.77	17 400	3.98	21 400	4.16	
MTZ064	45	5 550	2.91	7 480	3.35	9 820	3.73	12 600	4.05	15 900	4.32	19 800	4.57	24 300	4.79	
MTZ072	45	6 300	3.49	8 540	3.96	11 200	4.39	14 400	4.77	18 200	5.11	22 600	5.39	27 700	5.63	
MTZ080	45	7 290	4.08	9 860	4.64	12 900	5.12	16 400	5.54	20 600	5.89	25 300	6.19	30 800	6.45	
MTZ100	45	7 870	4.81	11 000	5.47	14 800	6.04	19 300	6.52	24 500	6.92	30 700	7.26	37 800	7.56	
MTZ125	45	11 500	6.13	15 500	6.97	20 100	7.69	25 600	8.31	31 900	8.84	39 300	9.30	47 700	9.69	
MTZ144	45	12 700	7.07	17 000	7.92	22 200	8.70	28 200	9.42	35 300	10.04	43 500	10.58	52 900	11.01	
MTZ160	45	15 400	8.21	20 200	9.20	25 800	10.09	32 500	10.91	40 300	11.68	49 400	12.42	59 900	13.16	
MTZ200	45	15 700	9.61	22 000	10.94	29 600	12.08	38 600	13.03	49 100	13.84	61 400	14.53	75 500	15.11	
MTZ250	45	23 000	12.26	30 900	13.93	40 200	15.37	51 100	16.61	63 800	17.68	78 500	18.59	95 400	19.38	
MTZ288	45	25 300	14.13	34 000	15.83	44 400	17.41	56 500	18.83	70 600	20.09	87 000	21.16	105 900	22.02	
MTZ320	45	30 700	16.43	40 300	18.39	51 700	20.17	65 100	21.81	80 700	23.36	98 800	24.85	119 700	26.32	

Legend: To: Evaporating temperature in °C      Qo: Cooling capacity in W      Superheat = 11.1 K      Voltage: 400 V / 3 / 50 Hz  
 Tc: Condensing temperature in °C      Pe: Power input in kW      Subcooling = 8.3 K

⚠ Note: Qo = cooling capacity (watts)  
 Pe = motor/power input (KW)

# Reciprocating compressors – Commercial

## Performance data - NTZ, MT and MTZ

Model	To	-15			-10		-5		0		5		10		15		20	
		Tc	Qo	Pe	Qo	Pe	Qo	Pe	Qo	Pe	Qo	Pe	Qo	Pe	Qo	Pe	Qo	Pe
		<b>MTZ018</b>	45	700	0.61	1 050	0.69	1 470	0.76	1 970	0.82	2 570	0.87	3 270	0.91	4 090	0.93	5 020
<b>MTZ022</b>	45	940	0.72	1 370	0.81	1 900	0.91	2 550	0.99	3 320	1.06	4 240	1.11	5 310	1.15	6 560	1.16	
<b>MTZ028</b>	45	1 230	0.91	1 720	1.02	2 350	1.13	3 130	1.23	4 090	1.34	5 260	1.43	6 650	1.51	8 300	1.58	
<b>MTZ032</b>	45	1 430	1.09	2 020	1.25	2 770	1.40	3 690	1.54	4 810	1.66	6 160	1.76	7 760	1.83	9 630	1.86	
<b>MTZ036</b>	45	2 050	1.29	2 740	1.45	3 580	1.60	4 590	1.74	5 780	1.86	7 170	1.97	8 790	2.05	10 660	2.10	
<b>MTZ040</b>	45	2 450	1.47	3 160	1.61	4 000	1.75	4 980	1.89	6 100	2.01	7 390	2.12	8 860	2.21	10 520	2.27	
<b>MTZ044</b>	45	2 080	1.29	2 910	1.49	3 940	1.67	5 190	1.83	6 710	1.95	8 540	2.05	10 710	2.13	13 270	2.17	
<b>MTZ050</b>	45	2 360	1.57	3 340	1.80	4 560	2.00	6 040	2.17	7 820	2.31	9 950	2.42	12 470	2.51	15 410	2.57	
<b>MTZ056</b>	45	2 290	1.64	3 380	1.88	4 730	2.11	6 400	2.31	8 420	2.49	10 820	2.64	13 650	2.77	16 940	2.86	
<b>MTZ064</b>	45	2 700	1.87	4 010	2.17	5 600	2.43	7 510	2.67	9 780	2.87	12 440	3.04	15 550	3.18	19 130	3.27	
<b>MTZ072</b>	45	3 200	2.16	4 660	2.50	6 430	2.81	8 560	3.08	11 090	3.33	14 070	3.54	17 540	3.74	21 560	3.92	
<b>MTZ080</b>	45	4 130	2.59	5 700	2.93	7 620	3.24	9 950	3.54	12 740	3.80	16 040	4.05	19 920	4.27	24 430	4.48	
<b>MTZ100</b>	45	4 660	3.25	6 550	3.65	8 860	4.02	11 680	4.35	15 050	4.63	19 050	4.84	23 730	4.96	29 170	4.98	
<b>MTZ125</b>	45	5 870	3.63	8 230	4.17	11 090	4.69	14 520	5.16	18 590	5.57	23 380	5.89	28 950	6.09	35 380	6.18	
<b>MTZ144</b>	45	7 880	4.85	10 680	5.40	14 060	5.94	18 090	6.46	22 850	6.93	28 420	7.34	34 870	7.67	42 290	7.92	
<b>MTZ160</b>	45	8 770	5.23	11 800	5.84	15 470	6.45	19 890	7.06	25 130	7.65	31 300	8.21	38 480	8.72	46 760	9.18	
<b>MTZ200</b>	45	9 320	6.50	13 090	7.29	17 730	8.04	23 350	8.70	30 100	9.26	38 090	9.68	47 460	9.92	58 340	9.96	
<b>MTZ250</b>	45	11 740	7.25	16 460	8.35	22 180	9.39	29 040	10.33	37 190	11.14	46 760	11.77	57 910	12.19	70 770	12.35	
<b>MTZ288</b>	45	15 750	9.71	21 370	10.81	28 130	11.89	36 190	12.91	45 710	13.85	56 840	14.67	69 750	15.35	84 580	15.84	
<b>MTZ320</b>	45	17 540	10.46	23 600	11.67	30 950	12.90	39 780	14.11	50 260	15.29	62 590	16.41	76 950	17.44	93 530	18.37	

Model	To	-30			-25		-20		-15		-10		-5		0		5		10	
		Tc	Qo	Pe	Qo	Pe	Qo	Pe	Qo	Pe	Qo	Pe	Qo	Pe	Qo	Pe	Qo	Pe	Qo	Pe
		<b>MTZ018</b>	45	390	0.69	650	0.83	980	0.96	1 400	1.09	1 900	1.21	2 520	1.31	3 250	1.40	4 110	1.47	5 120
<b>MTZ022</b>	45	640	0.86	980	1.03	1 410	1.19	1 960	1.34	2 620	1.48	3 440	1.61	4 410	1.72	5 550	1.82	6 880	1.90	
<b>MTZ028</b>	45	760	1.05	1 250	1.30	1 850	1.53	2 570	1.75	3 430	1.96	4 450	2.14	5 640	2.31	7 040	2.45	8 640	2.56	
<b>MTZ032</b>	45	1 040	1.20	1 580	1.46	2 240	1.71	3 030	1.94	3 980	2.16	5 110	2.36	6 440	2.55	7 980	2.71	9 760	2.86	
<b>MTZ036</b>	45	1 300	1.50	1 930	1.78	2 690	2.06	3 600	2.33	4 670	2.58	5 930	2.81	7 400	3.01	9 100	3.19	11 050	3.34	
<b>MTZ040</b>	45	1 600	1.70	2 320	2.05	3 160	2.37	4 160	2.67	5 330	2.95	6 700	3.20	8 290	3.44	10 130	3.65	12 230	3.84	
<b>MTZ044</b>	45	1 360	1.60	2 100	1.94	2 990	2.25	4 070	2.52	5 370	2.77	6 910	3.00	8 740	3.20	10 890	3.38	13 370	3.54	
<b>MTZ050</b>	45	1 700	1.94	2 500	2.29	3 510	2.62	4 750	2.93	6 260	3.22	8 070	3.48	10 220	3.71	12 740	3.91	15 680	4.07	
<b>MTZ056</b>	45	1 730	2.04	2 620	2.43	3 710	2.81	5 060	3.17	6 710	3.51	8 690	3.83	11 060	4.11	13 840	4.36	17 090	4.57	
<b>MTZ064</b>	45	2 160	2.32	3 200	2.83	4 480	3.32	6 060	3.78	7 980	4.20	10 300	4.60	13 070	4.96	16 330	5.28	20 150	5.55	
<b>MTZ072</b>	45	2 550	2.74	3 670	3.25	5 080	3.75	6 810	4.23	8 920	4.69	11 450	5.11	14 450	5.51	17 970	5.87	22 050	6.19	
<b>MTZ080</b>	45	3 170	3.15	4 530	3.85	6 170	4.48	8 130	5.07	10 470	5.61	13 230	6.11	16 470	6.57	20 240	7.01	24 580	7.41	
<b>MTZ100</b>	45	3 240	4.01	4 930	4.80	6 960	5.53	9 390	6.18	12 280	6.76	15 700	7.26	19 710	7.70	24 370	8.06	29 760	8.34	
<b>MTZ125</b>	45	4 660	5.16	6 620	6.02	9 060	6.86	12 060	7.67	15 710	8.44	20 080	9.16	25 250	9.83	31 300	10.44	38 310	10.98	
<b>MTZ144</b>	45	5 700	6.08	8 060	7.05	10 920	8.00	14 370	8.91	18 490	9.78	23 380	10.60	29 110	11.36	35 770	12.06	43 450	12.69	
<b>MTZ160</b>	45	6 280	6.80	8 870	7.95	12 010	9.04	15 790	10.08	20 310	11.08	25 640	12.05	31 900	13.01	39 160	13.97	47 540	14.95	
<b>MTZ200</b>	45	6 480	8.02	9 860	9.60	13 920	11.05	18 770	12.36	24 560	13.52	31 400	14.53	39 420	15.39	48 750	16.11	59 510	16.68	
<b>MTZ250</b>	45	9 320	10.32	13 230	12.05	18 110	13.73	24 120	15.34	31 420	16.88	40 160	18.32	50 500	19.66	62 600	20.88	76 620	21.96	
<b>MTZ288</b>	45	11 410	12.17	16 120	14.11	21 840	16.00	28 740	17.82	36 990	19.56	46 760	21.20	58 220	22.72	71 550	24.12	86 900	25.37	
<b>MTZ320</b>	45	12 550	13.61	17 740	15.90	24 030	18.08	31 590	20.15	40 610	22.15	51 280	24.10	63 790	26.03	78 330	27.95	95 070	29.90	

Legend: To: Evaporating temperature in °C      Qo: Cooling capacity in W      Superheat = 10 K      Voltage: 400 V / 3 / 50 Hz  
 Tc: Condensing temperature in °C      Pe: Power input in kW      Subcooling = 0 K

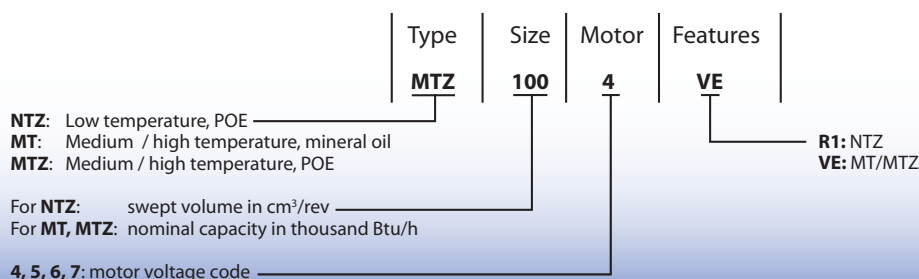

# Reciprocating compressors – Commercial

## Ordering - NTZ (low temperature range)

Model	4	5	6	7	Swept volume cm <sup>3</sup> /rev	Displacement m <sup>3</sup> /h at 2900 rpm	Cylinder number	Oil charge dm <sup>3</sup>	Net weight kg
	460/3/60 400/3/50	230/1/50	230/3/50	575/3/60 500/3/50					
Low back pressure Applications	NTZ048	120F0001	120F0087		48	8.4	1	0.95	21
	NTZ068	120F0002	120F0088		68	11.8	1	0.95	23
	NTZ096	120F0003			96	16.7	2	1.8	35
	NTZ108	120F0004			108	18.7	2	1.8	35
	NTZ136	120F0005			136	23.6	2	1.8	35
	NTZ215	120F0006			215	37.5	4	3.9	62
	NTZ271	120F0007			271	47.3	4	3.9	64
	NTZ430	120F0024			2 x 215	2 x 37.5	2 x 4	2 x 3.9	138
NTZ542	120F0025			2 x 271	2 x 47.3	2 x 4	2 x 2.9	142	

Cross reference list LTZ to NTZ (new) - dimensions, pipe connections and foot print of NTZ is similar to the corresponding LTZ

Type LTZ	Type NTZ	Code No. - Single pack NTZ
LTZ22-5VI	NTZ48-5VI	120F0087
LTZ28-5VI	NTZ68-5VI	120F0088
LTZ22-4VI	NTZ48-4VI	120F0001
LTZ28-4VI	NTZ68-4VI	120F0002
LTZ40-4VI	NTZ96-4VI	120F0003
LTZ44-4VI	NTZ108-4VI	120F0004
LTZ50-4VI	NTZ136-4VI	120F0005
LTZ88-4VI	NTZ215-4VI	120F0006
LTZ100-4VI	NTZ271-4VI	120F0007

Model	Nominal voltage	Height		Diameter			
		400/3/50 460/3/60	230/1/50				
		H	H1		H2	D	
Motor voltage code	4	5	mm	mm	mm	mm	
NTZ048	1 cylinder	●	●	333	263	68	224
NTZ068		●	●				
NTZ096	2 cylinders	●		413	265	74	288
NTZ108		●					
NTZ136	4 cylinders	●		519	233	125	352
NTZ215		●					
NTZ271		●					

M-HBP: Medium High Back Pressure - LBP: Low Back Pressure

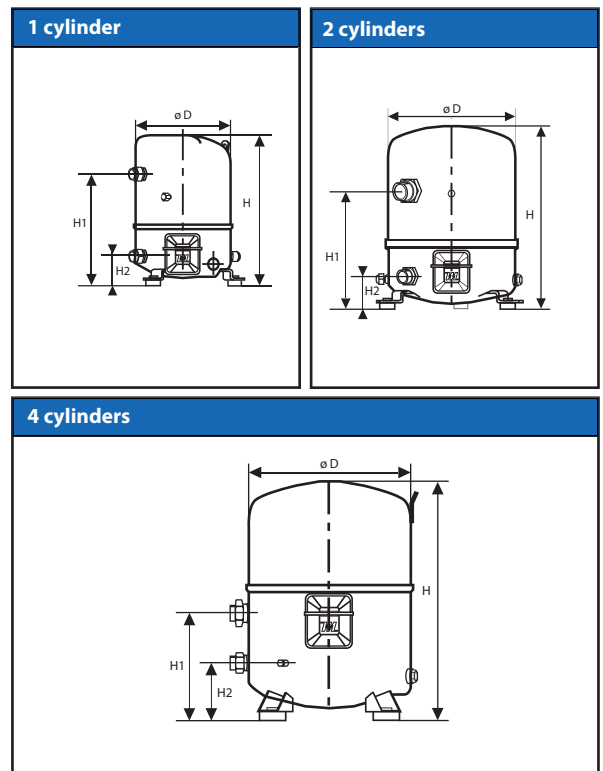

⚠ Note: NTZ series replaced old LTZ compressors.

# Reciprocating compressors – Commercial

# Spare Parts

## Dimensions

**MT / MTZ / NTZ  
1 cylinder**

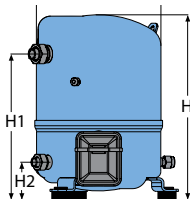

D : 224 mm  
H : 333/358 mm  
H1 : 263 mm  
H2 : 68 mm

**MT / MTZ / NTZ  
2 cylinders**

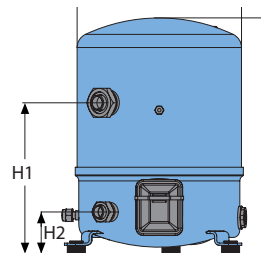

D : 288 mm  
H : 413 mm  
H1 : 265 mm  
H2 : 74 mm

**MT / MTZ / NTZ  
4 cylinders**

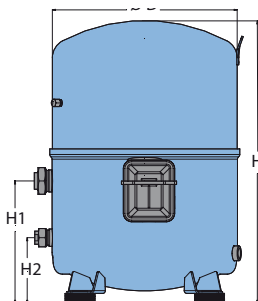

D : 352 mm  
H : 519 / 540mm  
H1 : 233 mm  
H2 : 125 mm

**MT / MTZ / NTZ Tandem  
2 x 4 cylinders**

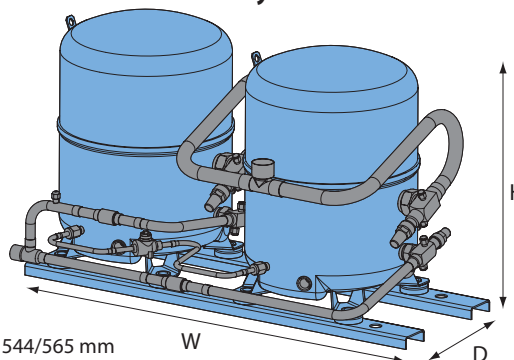

H : 544/565 mm  
D : 515 mm  
W : 925 mm

## Reciprocating Compressors - Commercial

## Common Spare Parts

Type	Description	Comp Model/s	Ordering Code	Old code	
Sump Heater	PTC Insertion Sump Heater 27 Watt	All Models	<b>120Z0459</b>	7773001	
	Belt Type 65W, 230V	MT(Z)044-081, NTZ096-136	<b>7773107</b>	7773003	
	Belt Type 75W, 230V	MT(Z)100-160, NTZ215-271	<b>7773108</b>	7773004	
	Belt Type 65W, 400V	MT(Z)044-081, NTZ096-136	<b>7773117</b>	-	
1 Ph Electrics	Belt Type 75W, 400V	MT(Z)100-160, NTZ215-271	<b>7773118</b>	-	
	CSR Electrics Kit-Relay & Capacitors	MT(Z)18-28, NTZ48-68	<b>7701022</b>	-	
Terminal Cover	Terminal Box Cover and Spring	MT(Z)32 & 36	<b>7701023</b>	-	
		MT(Z)18-45, NTZ048-136	<b>8156134</b>	-	
Mounting Kit	Rubber Mounts, Washers & Screws	MT(Z)50-160, NTZ215-271	<b>8156135</b>	-	
		MT(Z)18-81, NTZ048-136	<b>8156001</b>	-	
Gaskets	Sight Glass Gasket	MT(Z)100-160, NTZ215-271	<b>8156007</b>	-	
	1" Rotolock Connection Gasket	MT(Z)18-160, NTZ048-271	<b>8156129</b>	-	
	11/4" Rotolock Connection Gasket	1" Gasket	<b>8156130</b>	-	
Hoods	Compressor Acoustic Hood	11/4" Rotolock Connection Gasket	<b>8156131</b>	-	
		13/4" Rotolock Connection Gasket	13/4" Gasket	<b>8156132</b>	-
		MT(Z)18-40, NTZ048-068	<b>120Z0471</b>	7755001	
Solder Sleeves	Compressor Acoustic Hood	MT(Z)44-81, NTZ096-136	<b>120Z0472</b>	7755002	
		MT(Z)100-160, NTZ215-271	<b>120Z0473</b>	7755003	
		P01 1" Rotolock 3/8" ODF	1" Rotolock - 3/8" ODF	<b>7953004</b>	-
Lubricants	P02 13/4" Rotolock 11/8" ODF	1/3/4" Rotolock - 11/8" ODF	<b>8153005</b>	-	
	P04 11/4" Rotolock 3/4" ODF	11/4" Rotolock - 3/4" ODF	<b>8153008</b>	-	
	P06 1" Rotolock 1/2" ODF	1" Rotolock 1/2" ODF	<b>8153007</b>	-	
	P07 13/4" Rotolock 7/8" ODF	13/4" Rotolock 7/8" ODF	<b>8153013</b>	-	
	Mineral Oil 160P - 2 Litre	MT Old R22/R502	<b>7754001</b>	-	
Mineral Oil 160P - 5 Litre	MT Old R22/R502	<b>7754002</b>	-		
POE Oil 160PZ - 1 Litre	MTZ & NTZ	<b>7754019</b>	-		
POE Oil 160PZ - 2 Litre	MTZ & NTZ	<b>7754020</b>	-		