

GAS PRESSURE REGULATORS CATALOG

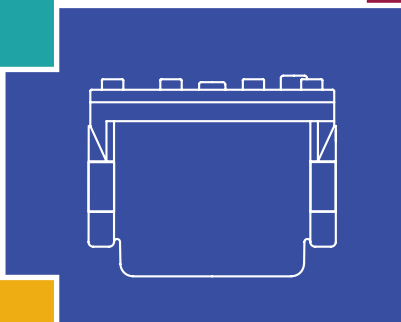
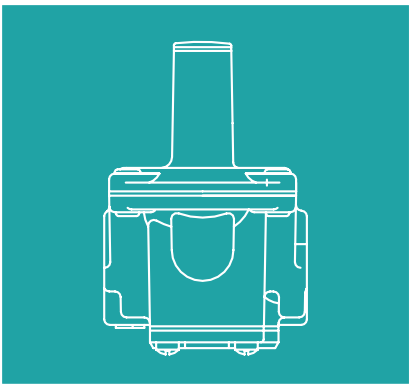
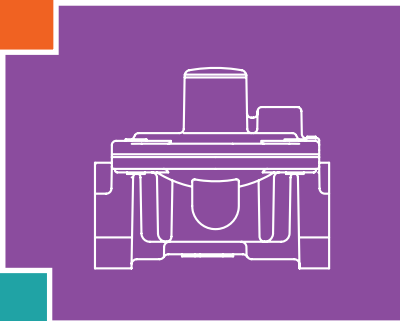
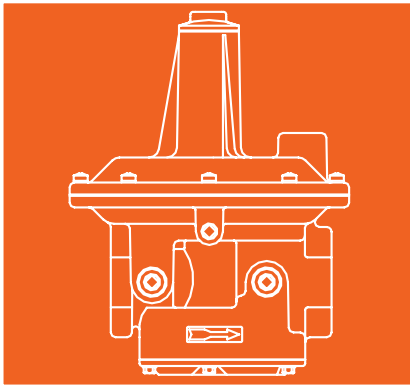

⚠ WARNING

Service and installation must be performed by a trained/experienced service technician.

All products used with combustible gas **must** be installed and used **strictly** in accordance with the instructions of the Original Equipment Manufacturer (OEM) and with all applicable government codes and regulations, e.g. plumbing, mechanical, and electrical codes and practices. Maxitrol products should be installed and operated in accordance with Maxitrol Safety Warning Instructions.

Maxitrol Company is NOT responsible for any errors or omissions in reliance by anyone of any information set forth in this catalog without additional reference to local requirements and applicable ordinances or codes.

Other worldwide approvals and certifications available upon inquiry.



Appliance Regulators

RV Series Appliance Regulators: Rubber Seat Poppet Design.....4-9
 RV Series Appliance Regulators: Straight-Thru-Flow Design.....10-13
 325 Series Appliance Regulators: Lever Acting Design.....14-17
 R/RS Series Appliance Regulators: Balanced Valve Design.....18-21
 210 Series Appliance Regulators: Balanced Valve Design.....22-31
 RZ and 210Z Series Appliance Regulators: Zero Governor Design.....32-37
 220 Series Appliance Regulators: Pilot Loaded Design.....38-41
 SR Series Appliance Regulators: Two-Stage Design.....42-45

Line Regulators

325L Series Line Regulators for 2PSI: Lever Acting Design.....46-49
 325L Series Line Regulators for 5PSI: Lever Acting Design.....50-55

Spring Selection Chart

.....56-57

Sizing a Regulator

.....58-59

Accessories

Venting.....60-61
 Pressure Tap Connector.....61
 Dust Cap.....61
 Tamper Proof Seals.....61
 Choosing a Vent Accessory.....62

Definitions

.....63

GF Series Gas and Air Filters

.....64-65

RV SERIES

Rubber Seat Poppet Design

The compact RV poppet regulators are designed primarily for main burner and pilot load applications. Typical applications include residential and commercial cooking appliances, barbecues, hearth products, and pilot lines. Maxitrol rubber seat poppet models offer the ultimate in design features and performance capabilities to meet your specific appliance or utility requirements.

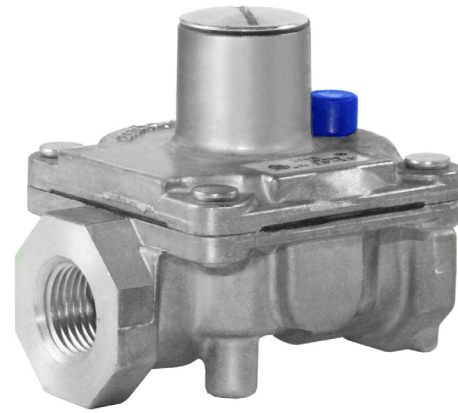

RV47

Specifications

- Pipe Sizes** 1/8" thru 3/4" threaded connections with NPT or ISO7-1 threads.
(Other connections available, please consult Maxitrol Company.)
- Housing Material** RV12, RV20, RV47, RV48, CV47: aluminum.
- Mounting** All models, with the exception of "D" suffix models, are suitable for multi-positional mounting. Other than upright position will result in a slight difference in outlet pressure. "D" suffix models are to be mounted upright only.
NOTE: All Maxitrol gas pressure regulators should be installed and operated in accordance with Maxitrol Safety Warning Instructions (see GPR_MI_EN.ES or GPR_CSA_MI_EN.FR).
- Certifications** RV Series: ANSI Z21.18/CSA 6.3 Gas Appliance Pressure Regulators.
CV47 Series: ANSI Z21.78/CSA 6.20 Combination Gas Controls for Gas Appliances.
- Gas Types (RV Series)** Suitable for natural, manufactured, mixed gases, liquefied petroleum gases, and LP gas-air mixtures.
- Gas Types (CV47 Series)** Suitable for natural or liquefied petroleum gases.
- Maximum Inlet Pressure** 1/2 psi (3.4 kPa)
- Emergency Exposure Limits** 2.5 psi (17.2 kPa)
- Ambient Temperature Ranges**... RV20, RV47, RV48, CV47: 32° to 225°F (0° to 107°C)
RV12: -40° to 225°F (-40° to 107°C)
RV12T: -40° to 275°F (-40° to 135°C)
RV20T: -40° to 300°F (-40° to 148°C)
RV48T: 32° to 275°F (0° to 135°C)
- Minimum Regulation**..... Suitable for pilot flow applications. (P) (Circle P) (0.15 CFH NG), (P) (Delta P) (0.50 CFH NG), None (1.5 CFH NG), N Models (3 CFH NG).



Model Designations

Models having a suffix letter or a combination of suffix letters listed below indicates the design modifications described.

- A** Limited spring adjustment (RV47A & CV47A**, short stack*).
- C** Convertible regulators***; preset to deliver outlet pressures for either natural or LP gases.
(RV20, RV47, RV48, CV47)
- D** Integral ball check limiting device; permits higher maximum individual load.
(see Capacities and Pressure Drop, page 6)
- E** Excessive pressure rated.
- F** Factory-set; fixed/non-adjustable regulator.
- I** Left side integral manual valve; outlet faces main inlet (CV47).
- L** Integral vent limiting orifice as the breather hole.
- M** B.S.P. - PL parallel thread - conforms to ISO 7-1, where pressure tight joints are made on the threads.
- MK** B.S.P. - TR taper thread - conforms to ISO 7-1, where pressure tight joints are made on the threads.
- N** Internal by-pass orifice to prevent lockup. Main burner only (RV20, RV47, RV48, CV47).
- R** Right side+ integral manual valve; outlet faces main outlet (CV47).
- SR** Side pressure tap; right side+ 1/8" NPT (RV20 & RV47).
- S** Side pressure tap; left side+ 1/8" NPT (RV20, RV47, CV47).
- T** Higher ambient temperature range.
- V** Threaded vent connector, 5/16-24 for 1/8" tubing connection (RV20).

* Short stack models have an adjustment range of less than 2" w.c. (0.5 kPa); these models are advantageous where installation must be made in a limited space.

** CV47A is best described as a RV47A with an extra regulated outlet. This outlet contains an integral manual valve located on the valve body's side.

*** Convertible regulators are designed to deliver either of two fixed outlet pressures for natural or LP gases.

RV20C: NAT GAS: 4.0" w.c. (1.0 kPa); LP: 10" w.c. (2.5 kPa)

RV47C, CV47C: NAT GAS: 4.0", 5.0" or 6.0" w.c. (1.0, 1.3, or 1.5 kPa); LP: 10" or 11" w.c. (2.5 or 2.8 kPa)

RV48C: NAT GAS: 5" w.c. (1.3 kPa); LP: 10" w.c. (2.5 kPa)

+ Left and right is determined when viewing regulator from outlet side with stack up.

NOTE: The RV48 model may be used with either a 12A04 ball check device, or a 12A06 fixed orifice vent limiting device. See page 62 for vent accessory options.

RV SERIES

Rubber Seat Poppet Design

Capacities and Pressure Drop

Capacities expressed in Btu/h (m³/h) @ 0.64 sp gr gas

Model	Pipe Size	Pressure Drop @ 0.3" w.c. or (0.07 kPa)	Range of Regulation		Individual Load	
			Main Burner	Main Burner & Pilot	Fixed Orifice	Ball Check Device
RV12	1/8" x 1/8"*	14,800 (0.42)	30,000 (0.85)	25,000 (0.71)	20,000 (0.56)	---
	3/16" x 3/16" Loxit	8,800 (0.25)		15,000 (0.43)		
RV20	1/4" x 1/4" 3/8" x 3/8"*	30,000 (0.85)	65,000 (1.84)	50,000 (1.4)	30,000 (0.85)	---
RV20C	1/4" x 1/4" 3/8" x 3/8"	30,000 (0.85)	75,000 (2.11)	50,000 (1.4)	15,000 (0.42)	---
CV47 RV47	3/8" x 3/8"	55,000 (1.5)	125,000 (3.5)	90,000 (2.5)	40,000 (1.1)	125,000 (3.5)
	1/2" x 1/2"*	60,000 (1.7)				
CV47A or C RV47A or C	3/8" x 3/8"	55,000 (1.5)	125,000 (3.5)	125,000 (3.5)	40,000 (1.1)	125,000 (3.5)
	1/2" x 1/2"	60,000 (1.7)				
RV48	1/2" x 1/2"	130,000 (3.7)	230,000 (6.5)	230,000 (6.5)	40,000 (1.1)	160,000 (4.5)
	3/4" x 3/4"	150,000 (4.2)	250,000 (7.1)	250,000 (7.1)		
RV48C	1/2" x 1/2"	130,000 (3.7)	400,000 (11.3)	275,000 Nat (7.8)	40,000 (1.1)	160,000 (4.5)
	3/4" x 3/4"	150,000 (4.2)		275,000 LP (3.1)		

*Also available as Loxit connection.

NOTE: CSA maximum capacities vary with spring range and pipe size. Please contact Maxitrol directly for CSA maximums. Minimum main burner regulation capacity for all models (except "N") is 150 Btu/hr (0.0042 m³/h). See pages 58-59 for Regulator Sizing Requirements and Examples.

Spring Selection Chart: inches w.c. (kPa)

Model	Available Springs										
RV12	1 to 3.5* (0.25 to 0.9) Brown	2.8 to 5.2 (0.69 to 1.3) Plated	---	4 to 8 (1 to 2) Orange	---	---	---	---	6 to 10 (1.5 to 2.5) Red	8 to 12 (2 to 3) Blue	---
RV20	1 to 3.5* (0.25 to 0.9) Brown	2.8 to 5.2 (0.69 to 1.3) Plated	---	4 to 8 (1 to 2) Orange	---	---	---	---	6 to 10 (1.5 to 2.5) Red	8 to 12 (2 to 3) Blue	9 to 12* (2.25 to 3) Plated
RV47 CV47	1 to 3.5* (0.25 to 0.9) Brown	2.8 to 5.2 (0.69 to 1.3) Plated	3.8 to 4.3 (0.95 to 1.08) Black	4 to 8 (1 to 2) Orange	4 to 12 (1 to 3) Violet	4.7 to 5.3 (1.18 to 1.33) Green	---	5.6 to 6.4 (1.4 to 1.6) Red	6 to 10 (1.5 to 2.5) Red	8 to 12 (2 to 3) Blue	9.7 to 11.3 (2.42 to 2.83) Plated
RV48	1 to 3.5* (0.25 to 0.9) Brown	3.0 to 6.0 (0.75 to 1.5) Plated	---	4 to 8 (1 to 2) Orange	---	---	5 to 12 (1.25 to 3) Blue	---	6 to 10 (1.5 to 2.5) Red	8 to 12* (2 to 3) Blue	---

*Uncertified Spring

NOTE: See pages 56-57 for complete Spring Selection Chart.

RV SERIES

Rubber Seat Poppet Design

Dimensions

Model	Pipe Size	Vent	Swing Radius	Dimensions			
				A	B	C	D
RV12	1/8" 3/16"Loxit	Integral	1.4" (35 mm)	1.7" (43 mm)	0.4" (10 mm)	1.7" (43 mm)	1.4" (35 mm)
RV20	1/4", 3/8"	Integral or 5/16-24	1.6" (41 mm)	2.1" (54 mm)	0.5" (13 mm)	2.4" (61 mm)	1.8" (45 mm)
RV47 CV47	3/8", 1/2"	Integral "D" or "L" suffix	1.9" (48 mm)	2.5" (64 mm)	0.6" (16 mm)	2.9" (75 mm)	2.3" (57 mm)
RV47A CV47A			1.6" (41 mm)	2.3" (57 mm)			
RV48	1/2", 3/4"	Integral or 1/8" NPT, 12A04 or 12A06 vent limiting device	2" (51 mm)	2.8" (70 mm)	0.8" (19 mm)	3.4" (86 mm)	3" (76 mm)

NOTE: Dimensions are maximums and to be used only as an aid in designing clearance for the valve.
Actual production dimensions may vary somewhat from those shown.

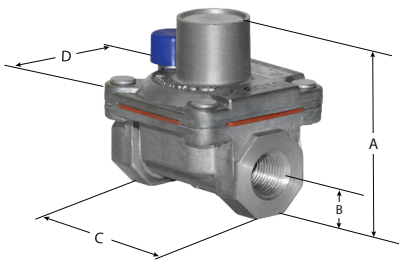

RV12

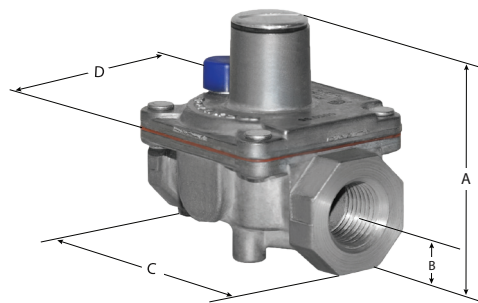

RV20

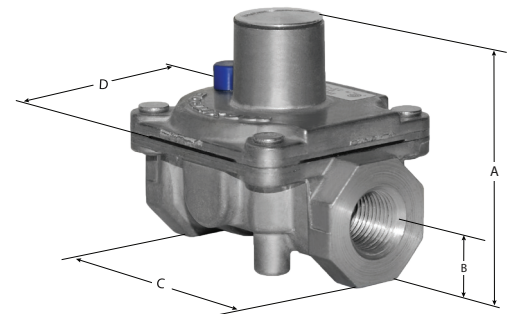

RV47, RV47A

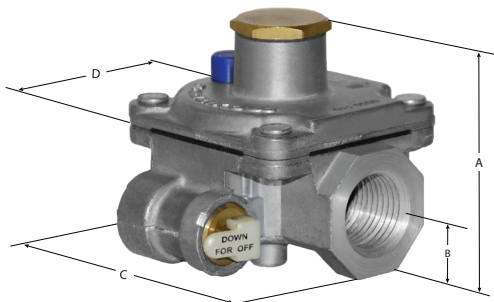

CV47, CV47A

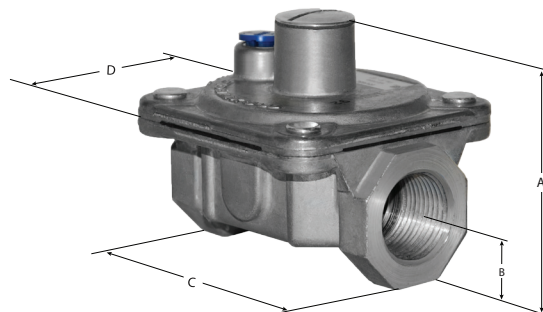

RV48

Rubber Seat Poppet Design

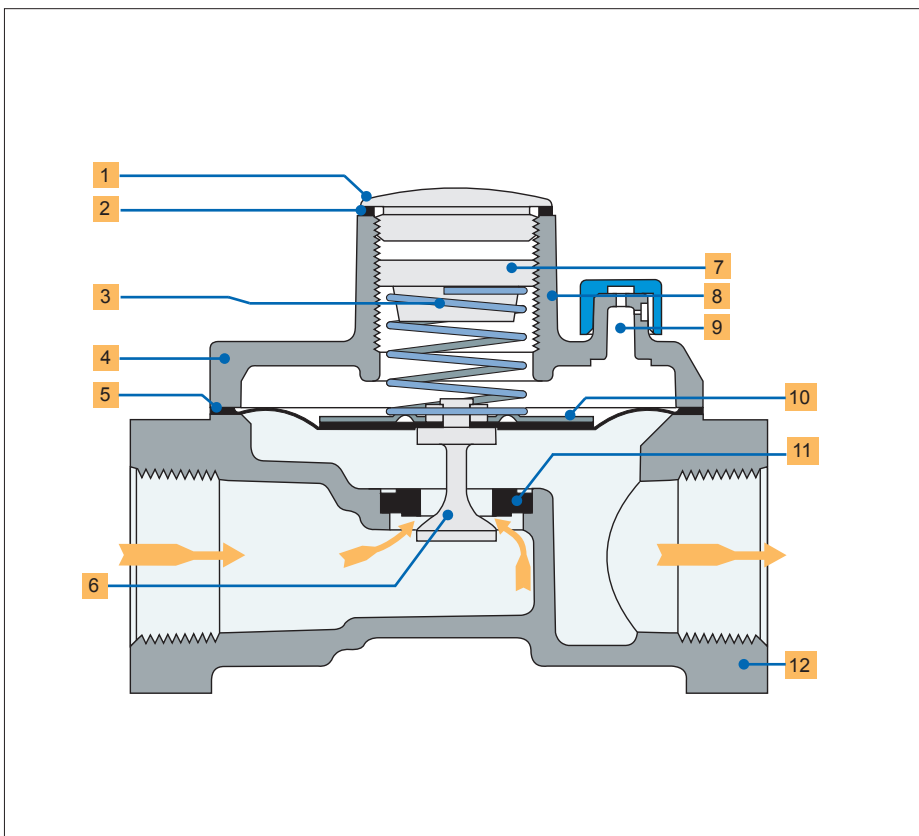

- 1** Seal Cap
- 2** Seal Cap Gasket
- 3** Spring
- 4** Top Housing
- 5** Diaphragm
- 6** Stem & Valve
- 7** Adjusting Screw
- 8** Stack
- 9** Vent
- 10** Diaphragm Plate
- 11** Rubber Seat
- 12** Bottom Housing

NOTE: Diagrams are graphical representations only and may differ from actual product.

RV SERIES

Straight-Thru-Flow Design

Maxitrol's original straight-thru-flow (STF) design regulators are non-lockup type regulators for high capacities at low inlet pressures. The difference between STF design and other type regulators is the conical valve. The cone principal permits gas to flow straight through the regulator without changing directions. Frictional flow resistance is reduced, resulting in greater capacity. An improved flow pattern provides accurate, sensitive regulation at extremely low pressure differentials. Typical applications include residential, commercial, and industrial gas-fired appliances and equipment used on low or medium pressure gas supplies.



RV81

Specifications

- Pipe Sizes** 1/2" to 3" threaded connections with NPT or ISO7-1 threads. 4" 150lb. flange (RV131 only).
- Housing Material** RV52, RV53, RV61, RV81, RV91, RV111: aluminum; RV131: cast iron.
- Mounting** RV52, RV53, RV61 are suitable for multi-positional mounting. If ball check vent limiting device is installed, mount in an upright position only. RV81, RV91, RV111, RV131, upright position only.
NOTE: All Maxitrol gas pressure regulators should be installed and operated in accordance with Maxitrol Safety Warning Instructions (see GPR_MI_EN.ES or GPR_CSA_MI_EN.FR).
- Certifications** RV52, RV53, RV61, RV81, RV91, RV111: ANSI Z21.18/CSA6.3 Gas Appliance Pressure Regulators.
- Gas Types** Suitable for natural, manufactured, mixed gases, liquefied petroleum gases, and LP gas-air mixtures.
- Maximum Inlet Pressure** CSA Certified: RV52, RV53, RV61, RV81, RV91, RV111: 1/2 psi (3.4 kPa)
Maxitrol Tested*: RV52, RV53: 1/2 psi (3.4 kPa)
RV61, RV81, RV91, RV111: 1 psi (6.9 kPa)
RV131: 2 psi (13.8 kPa)
- *Do not use if inlet pressure is more than 10 times desired outlet pressure.
- Emergency Exposure Limits** RV52, RV53: 3 psi (21 kPa)
RV61, RV81, RV91, RV111: 5 psi (34 kPa)
RV131: 15 psi (103 kPa)
- Gas Containment Limits** RV52, RV53: 15 psi (103 kPa)
RV61, RV81, RV91, RV111, RV131: 25 psi (172 kPa)
NOTE: Internal damage may occur when exposed to these pressures.
- Ambient Temperature Ranges**... RV52, RV53, RV61, RV81, RV91, RV111: -40° to 205°F (-40° to 96°C)
RV131: -40° to 125°F (-40° to 52°C)
- Minimum Regulation** RV52, RV53: 20 CFH; RV61: 25 CFH; RV81, RV91: 50 CFH; RV111, RV131: 250 CFH.



Capacities and Pressure Drop

Capacities expressed in CFH (m³/h) @ 0.64 sp gr gas

Model	Pipe Size	CSA MAX	Pressure Drop - inches w.c. (kPa)												
			0.1 (0.02)	0.2 (0.04)	0.3 (0.07)	0.4 (0.10)	0.5 (0.12)	0.6 (0.15)	0.7 (0.17)	0.8 (0.20)	0.9 (0.22)	1.0 (0.25)	2.0 (0.5)	3.0 (0.75)	4.0 (1.0)
RV52	1/2" x 1/2" 3/4" x 3/4"	450 (12.7)	151 (4.2)	214 (6.1)	262 (7.4)	302 (8.5)	338 (9.5)	370 (10.5)	400 (11.3)	427 (12.1)	453 (12.8)	478 (13.5)	676 (19.1)	828 (23.4)	956 (27.1)
RV53	3/4" x 3/4" 1" x 1"	710 (20.1)	217 (6.1)	306 (8.6)	375 (10.6)	433 (12.2)	484 (13.7)	530 (15)	573 (16.2)	612 (17.3)	650 (18.4)	684 (19.3)	968 (27.4)	1185 (33.5)	1369 (38.7)
RV61	1" x 1" 1 1/4" x 1 1/4"	1100 (31.1)	379 (10.7)	536 (15.1)	675 (19.1)	759 (21.5)	848 (24.0)	929 (26.3)	1004 (28.4)	1073 (30.4)	1138 (32.2)	1200 (34.0)	1742 (49.3)	2134 (60.4)	2464 (69.8)
RV81	1 1/4" x 1 1/4" 1 1/2" x 1 1/2"	2500 (70.8)	780 (22.1)	1102 (31.2)	1350 (38.2)	1559 (44.1)	1743 (49.5)	1909 (54.0)	2062 (58.4)	2204 (62.4)	2339 (66.2)	2465 (69.8)	3485 (98.7)	4269 (120)	4929 (139)
RV91	2" x 2" 2 1/2" x 2 1/2"	3275 (92.7)	1212 (34.3)	1714 (48.5)	2100 (59.4)	2424 (68.6)	2711 (76.7)	2969 (84.1)	3208 (90.8)	3429 (97.1)	3637 (103)	3834 (108)	5422 (153)	6640 (188)	7668 (217)
RV111	2 1/2" x 2 1/2" 3" x 3"	7500 (212)	2742 (78.0)	3878 (110)	4750 (134)	5485 (155)	6132 (175)	6718 (190)	7256 (205)	7757 (219)	8227 (233)	8572 (243)	12134 (343)	14862 (420)	17161 (486)
RV131	4" x 4"	---	4734 (134)	6695 (190)	8200 (232)	9468 (268)	10586 (300)	11596 (328)	12525 (354)	13390 (380)	14202 (402)	14971 (424)	21172 (600)	25930 (734)	29942 (848)

NOTE: See pages 58-59 for Regulator Sizing Requirements and Examples.

Spring Selection Chart: inches w.c. (kPa)

Model	CSA Certified Springs			Other Springs Available							
RV52	3 to 6 (0.75 to 1.5) Plated	4 to 8 (1 to 2) Orange	5 to 12 (1.25 to 3) Blue	1 to 3.5 (0.25 to 0.9) Brown	2 to 5 (0.5 to 1.25) Plated	3 to 8 (0.75 to 2) Pink	4 to 12 (1 to 3) Violet	---	---	---	---
RV53	3 to 6 (0.75 to 1.5) Plated	4 to 8 (1 to 2) Orange	5 to 12 (1.25 to 3) Blue	1 to 3.5 (0.25 to 0.9) Brown	2 to 5 (0.5 to 1.25) Plated	3 to 8 (0.75 to 2) Pink	4 to 12 (1 to 3) Violet	---	---	---	---
RV61	3 to 6 (0.75 to 1.5) Plated	4 to 8 (1 to 2) Orange	5 to 12 (1.25 to 3) Blue	1 to 3.5 (0.25 to 0.9) Brown	2 to 5* (0.5 to 1.25) Plated	3 to 8 (0.75 to 2) Pink	---	---	10 to 22 (2.5 to 5.5) Red	---	---
RV81	3 to 6 (0.75 to 1.5) Plated	4 to 8 (1 to 2) Orange	5 to 12 (1.25 to 3) Blue	1 to 3.5 (0.25 to 0.9) Brown	2 to 5 (0.5 to 1.25) Plated	3 to 8 (0.75 to 2) Pink	4 to 12 (1 to 3) Violet	5 to 15 (1.25 to 3.7) Green	10 to 22 (2.5 to 5.5) Red	---	---
RV91	3 to 6 (0.75 to 1.5) Plated	4 to 8 (1 to 2) Orange	5 to 12 (1.25 to 3) Blue	1 to 3.5 (0.25 to 0.9) Brown	2 to 5 (0.5 to 1.25) Plated	3 to 8 (0.75 to 2) Pink	4 to 12 (1 to 3) Violet	5 to 15 (1.25 to 3.7) Green	10 to 22 (2.5 to 5.5) Red	---	---
RV111	3 to 6 (0.75 to 1.5) Plated	4 to 8 (1 to 2) Orange	5 to 12 (1.25 to 3) Blue	1 to 3.5 (0.25 to 0.9) Brown	2 to 5 (0.5 to 1.25) Plated	3 to 8 (0.75 to 2) Pink	4 to 12 (1 to 3) Violet	5 to 15 (1.25 to 3.7) Green	10 to 22 (2.5 to 5.5) Red	---	---
RV131	3 to 6 (0.75 to 1.5) Plated	---	5 to 12 (1.25 to 3) Blue	---	2 to 5 (0.5 to 1.25) Plated	3 to 8 (0.75 to 2) Pink	4 to 12 (1 to 3) Violet	---	10 to 22 (2.5 to 5.5) Red	15 to 30 (3.7 to 7.5) Yellow	20 to 42 (5 to 10.5) Black

NOTE: The area within the heavy line indicates CSA certified springs. See pages 56-57 for complete Spring Selection Chart.

* The 2 to 5 inches w.c. (0.5 to 1.25 kPa) spring is also CSA certified for the RV61

RV SERIES

Straight-Thru-Flow Design

Dimensions

Model	Pipe Size	Vent Connection	Swing Radius	Dimensions			
				A	B	C	D
RV52	1/2", 3/4"	1/8" NPT	3.6" (91 mm)	4.9" (124 mm)	3.2" (81 mm)	3.3" (83 mm)	1.3" (32 mm)
RV53	3/4", 1"	1/8" NPT	3.9" (99 mm)	5.2" (132 mm)	3.8" (95 mm)	3.9" (99 mm)	1.3" (33 mm)
RV61	1", 1 1/4"	1/8" NPT	4.8" (122 mm)	6.4" (164 mm)	4.4" (111 mm)	5.4" (138 mm)	1.6" (41 mm)
RV81	1 1/4", 1 1/2"	3/8" NPT	6.4" (162 mm)	8.4" (213 mm)	6" (153 mm)	7" (178 mm)	2" (51 mm)
RV91	2"	1/2" NPT	8.5" (216 mm)	10.8" (275 mm)	6.5" (165 mm)	9.1" (232 mm)	2.3" (60 mm)
	2 1/2"	1/4" NPT	8.3" (212 mm)	10.5" (267 mm)	7.1" (181 mm)	9.1" (232 mm)	2.4" (62 mm)
RV111	2 1/2" x 3"	3/4" NPT	11.5" (284 mm)	15.1" (373 mm)	9" (229 mm)	13.4" (324 mm)	3.5" (89 mm)
RV131	4"	3/4" NPT	18.2" (462 mm)	23.3" (592 mm)	13.9" (353 mm)	18" (457 mm)	5.1" (130 mm)

NOTE: Dimensions are maximums and to be used only as an aid in designing clearance for the valve.
Actual production dimensions may vary somewhat from those shown.

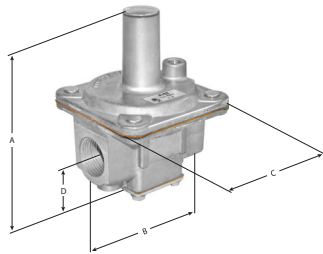

RV52, RV53

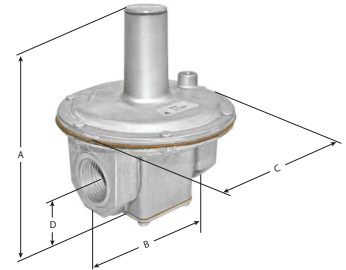

RV61

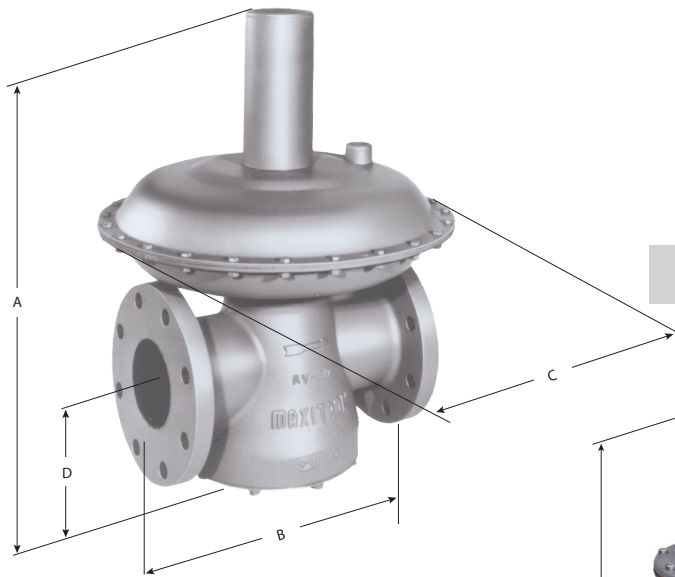

RV131

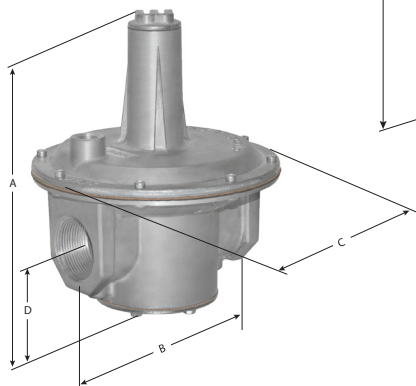

RV81, RV91

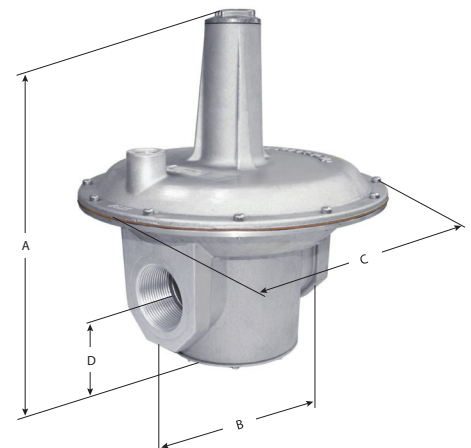

RV111

Straight-Thru-Flow Design

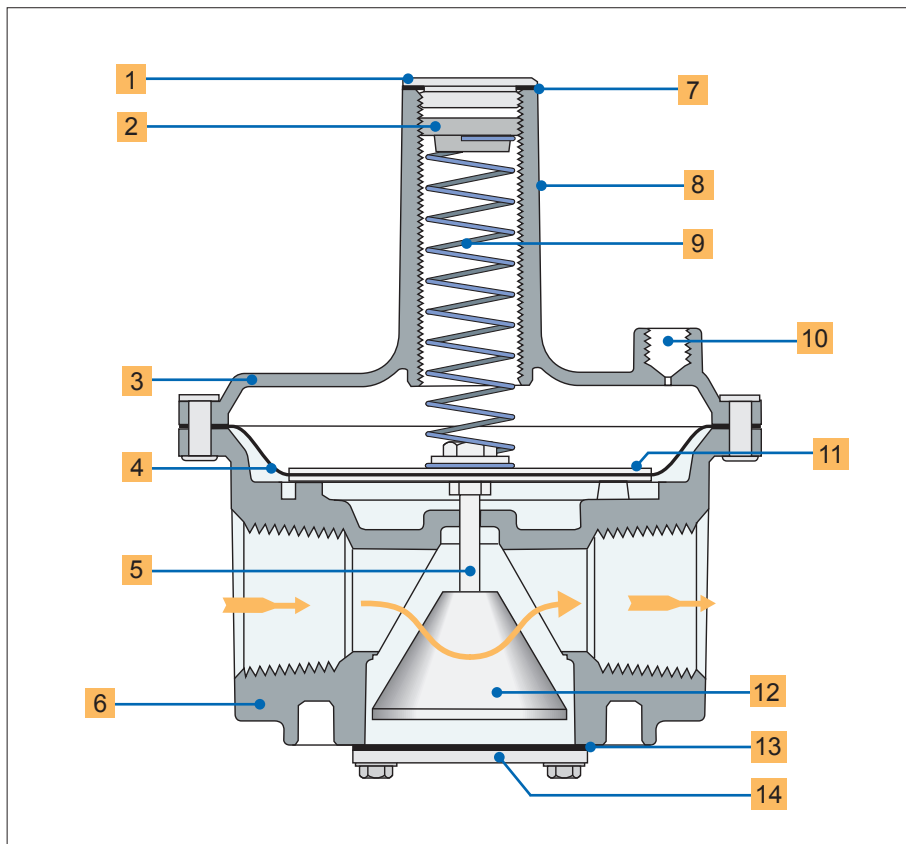

- 1** Welch Plug/Seal Cap
- 2** Vibration Resistant Adjusting Screw
- 3** Top Housing
- 4** Diaphragm
- 5** Stem
- 6** Bottom Housing
- 7** Seal Cap Gasket
- 8** Stack
- 9** Spring
- 10** Vent Connection
- 11** Diaphragm Plates
- 12** Valve
- 13** Bottom Plate Gasket
- 14** Bottom Plate

NOTE: Diagrams are graphical representations only and may differ from actual product.

325 SERIES

Lever Acting Design

Maxitrol's 325 Series pounds to inches regulators are for use on residential, commercial, and industrial applications.

The 325 Series features a high leverage valve linkage assembly to deliver positive dead-end lock-up. The regulators are capable of precise control from full flow down to pilot flow.

NOTE: The 325-9 will be available 2Q2014.



325-3

Specifications

Pipe Sizes 3/8" to 2" threaded connections with NPT or ISO7-1 threads.

Housing Material 325-3, 325-5, 325-7A, 325-9: aluminum.

Mounting Suitable for multi-positional mounting. If ball check vent limiting device is installed, mount in an upright position only.

NOTE: All Maxitrol gas pressure regulators should be installed and operated in accordance with Maxitrol Safety Warning Instructions (see GPR_MI_EN.ES or GPR_CSA_MI_EN.FR).

Certifications 325-3, 325-5: ANSI Z21.18/CSA 6.3 Gas Appliance Pressure Regulators.

Gas Types Suitable for natural, manufactured, mixed gases, liquefied petroleum gases, and LP gas-air mixtures.

Maximum Inlet Pressure CSA Certified: 325-3, 325-5: 2 psi (13.8 kPa), 5 psi (34.5 kPa)
Maxitrol Tested: 325-3, 325-5, 325-7A, 325-9: 10 psi (69 kPa)
With Vent Limiter 12A09, 12A39, or 12A49 Installed:
325-3, 325-5, 325-7A, 325-9: 5 psi (34.5 kPa) - Natural, 2 psi (13.8 kPa) - LP

Emergency Exposure Limits 65 psi (450 kPa) (inlet side only)

Maximum Individual Load Largest single appliance served by the regulator: 325-3: 100,000 Btu/h;
325-5: 325,000 Btu/h; 325-7A: 1,250,000 Btu/h, 325-9: 2,250,000 Btu/h

Capacity Total load of multiple appliances combined: 325-3: 150,000 Btu/h;
325-5: 325,000 Btu/h; 325-7A: 1,250,000 Btu/h; 325-9: 2,250,000 Btu/h

NOTE: Capacities are used to determine the maximum multiple appliance load. The largest single appliance served by the regulator should not exceed the maximum individual load specified above.

Ambient Temperature Ranges -40 to 205°F (-40 to 96°C)

Minimum Regulation Suitable for pilot flow applications. (P) (Circle P) (0.15 CFH NG), (Δ) (Delta P) 0.50 CFH NG).

Imblue Technology™ 325-3, 325-5, 325-7A, 325-9 models may be ordered with Imblue Technology™. Imblue Technology™ increases corrosion resistance and provides extra protection against the elements for regulators used in outdoor applications. Add suffix letter "B" to model number when ordering.

APPLIANCE REGULATORS



Capacities: based on 1" w.c. pressure drop, from set point**

Capacities expressed in CFH (m³/h) @ 0.64 sp gr gas

Model	Pipe Size	Outlet Pressure Set Point	CSA MAX CFH	Operating Inlet Pressure					
				0.5 psi (3.4 kPa)	0.75 psi (5.2 kPa)	1 psi (6.9 kPa)	2 psi (13.8 kPa)	5 psi (34.5 kPa)	10 psi (69.0 kPa)
325-3	3/8" x 3/8" 1/2" x 1/2"	4.0" w.c. (1.0 kPa)	150 (4.2)	160 (4.5)	190 (5.4)	220 (6.2)	220 (6.2)	300 (8.5)	320 (9.1)
		7.0" w.c. (1.7 kPa)	150 (4.2)	120 (3.4)	150 (4.2)	180 (5.1)	220 (6.2)	290 (8.2)	320 (9.1)
		10.0" w.c. (2.5 kPa)	150 (4.2)	100 (2.8)	120 (3.4)	150 (4.2)	220 (6.2)	280 (7.9)	320 (9.1)
325-5	1/2" x 1/2" 3/4" x 3/4" 1" x 1"	4.0" w.c. (1.0 kPa)	325 (9.2)	340 (9.6)	390 (11.0)	450 (12.7)	560 (15.9)	680 (19.3)	750 (21.2)
		7.0" w.c. (1.7 kPa)	325 (9.2)	260 (7.4)	360 (10.2)	410 (11.6)	530 (15.0)	680 (19.3)	750 (21.2)
		10.0" w.c. (2.5 kPa)	325 (9.2)	240 (6.8)	320 (9.1)	360 (10.2)	300 (8.5)	650 (18.4)	750 (21.2)
325-7A	1 1/4" x 1 1/4" 1 1/2" x 1 1/2"	4.0" w.c. (1.0 kPa)	—	850 (24.0)	1060 (30.0)	1190 (33.7)	1600 (45.3)	2090 (59.2)	2190 (62.0)
		7.0" w.c. (1.7 kPa)	—	780 (22.0)	950 (26.9)	1060 (30.0)	1500 (42.5)	1860 (52.7)	2060 (58.3)
		10.0" w.c. (2.5 kPa)	—	650 (18.4)	860 (24.4)	990 (28.0)	1300 (36.8)	1620 (45.9)	2060 (58.3)
325-9	1 1/2" x 1 1/2" 2" x 2"	4.0" w.c. (1.0 kPa)	—	1815 (51.4)	2075 (58.8)	2250 (63.7)	2660 (75.3)	3550 (100.5)	3750 (106.2)
		7.0" w.c. (1.7 kPa)	—	1430 (40.5)	1660 (47.0)	1960 (55.5)	2570 (72.8)	3420 (96.8)	3750 (106.2)
		10.0" w.c. (2.5 kPa)	—	1275 (36.1)	1450 (41.1)	1720 (48.7)	2160 (61.2)	3150 (89.2)	3750 (106.2)

NOTE: Maximum Individual Load: 325-3(B) is 100 CFH (2.8 m³/h); 325-5(B) is 325 CFH (9.2 m³/h); 325-7A(B) is 1250 CFH (35.4 m³/h); 325-9(B) is 2250 CFH (63.7). Approval based on use as an appliance regulator. **Set points (in CFH): 325-3(B) = 50; 325-5(B) = 150; 325-7A(B) = 500; 325-9(B)=1000. See pages 58-59 for Regulator Sizing Requirements and Examples.

Pressure Drop: 0.64 sp gr gas expressed in CFH (m³/h) (for system pressure drop calculations)

Model	7.0" w.c. (1.7 kPa)	0.5 psi (3.4 kPa)	0.75 psi (5.2 kPa)	1 psi (6.9 kPa)	2 psi (13.8 kPa)
325-3	145 (4.0)	204 (5.8)	250 (7.0)	289 (8.2)	—
325-5	400 (11.3)	550 (15.6)	670 (19.0)	770 (21.8)	—
325-7A	815 (23.1)	1149 (32.5)	1405 (39.8)	1624 (46.0)	2305 (65.3)
325-9	1360 (38.5)	2113 (59.8)	2557 (72.4)	2949 (83.5)	4059 (114.8)

Spring Selection Chart: inches w.c. (kPa) unless noted

Model Number	CSA Certified				Standard Spring	Other Springs Available			
	2 psi (13.8 kPa)		5 psi (34.5 kPa)			2 to 6	10 to 22	15 to 30	1 to 2 psi
325-3	5 to 9 (1.25 to 2.25) Plated	7 to 11 (1.7 to 2.7) White	6 to 10 (1.5 to 2.5) Plated	7 to 11 (1.7 to 2.7) White	4 to 12 (1.0 to 3.0) Violet	2 to 6 (0.5 to 1.5) Plated	10 to 22 (2.5 to 5.5) Red	15 to 30 (3.7 to 7.5) Yellow	1 to 2 psi (6.9 to 13.9) Tagged
325-5	5 to 9 (1.25 to 2.25) Plated	7 to 11 (1.7 to 2.7) White	6 to 10 (1.5 to 2.5) Plated	7 to 11 (1.7 to 2.7) White	4 to 12 (1.0 to 3.0) Violet	2 to 6 (0.5 to 1.5) Plated	10 to 22 (2.5 to 5.5) Red	15 to 30 (3.7 to 7.5) Yellow	1 to 2 psi (6.9 to 13.9) Tagged
325-7A	—	—	—	—	4 to 12 (1.0 to 3.0) Violet	2 to 5 (0.5 to 1.5) Plated	10 to 22 (2.5 to 5.5) Red	15 to 30 (3.7 to 7.5) Yellow	20 to 42 (5.0 to 10.4) Black
325-9	—	—	—	—	4 to 12 (1.0 to 3.0) Violet	2 to 5 (0.5 to 1.5) Plated	10 to 22 (2.5 to 5.5) Red	15 to 30 (3.7 to 7.5) Yellow	20 to 42 (5.0 to 10.4) Black

NOTE: See pages 56-57 for complete Spring Selection Chart.

325 SERIES

Lever Acting Design

Dimensions

Model	Pipe Size	Vent Connection	Swing Radius	Dimensions		
				A	B	C
325-3	3/8", 1/2"	1/8" NPT	3" (76 mm)	3.5" (89 mm)	4.2" (108 mm)	3.9" (98 mm)
325-5	1/2", 3/4", 1"	3/8" NPT	4.9" (124 mm)	5.3" (133 mm)	5.9" (149 mm)	5.4" (138 mm)
325-7A	1 1/4", 1 1/2"	1/2" NPT	6.1" (156 mm)	7.3" (184 mm)	8" (203 mm)	7" (178 mm)
325-9	1 1/2", 2"	1/2" NPT	7.8" (198 mm)	9.4" (239 mm)	10.8" (274 mm)	9.1" (231 mm)

NOTE: Dimensions are maximums and to be used only as an aid in designing clearance for the valve. Actual production dimensions may vary somewhat from those shown.

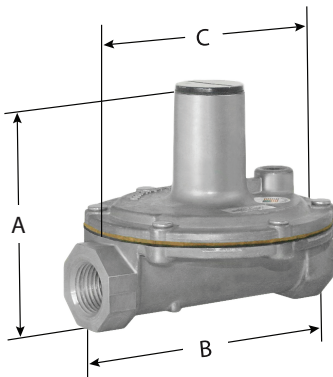

325-3

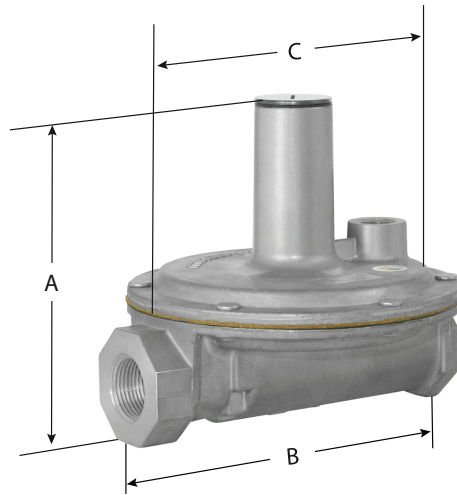

325-5

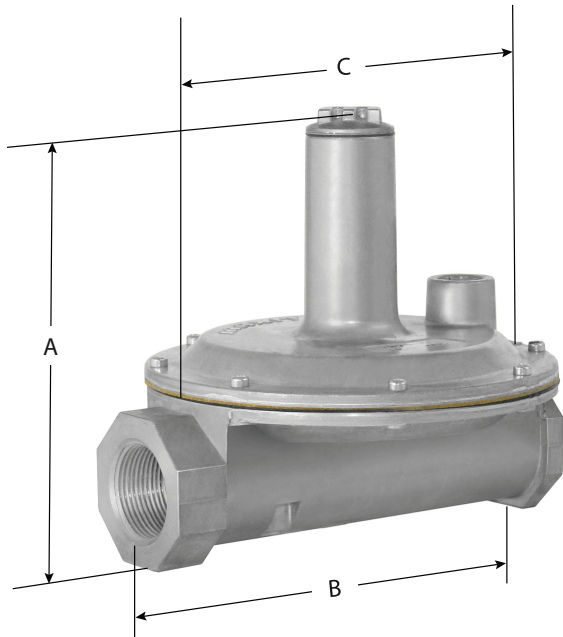

325-7A

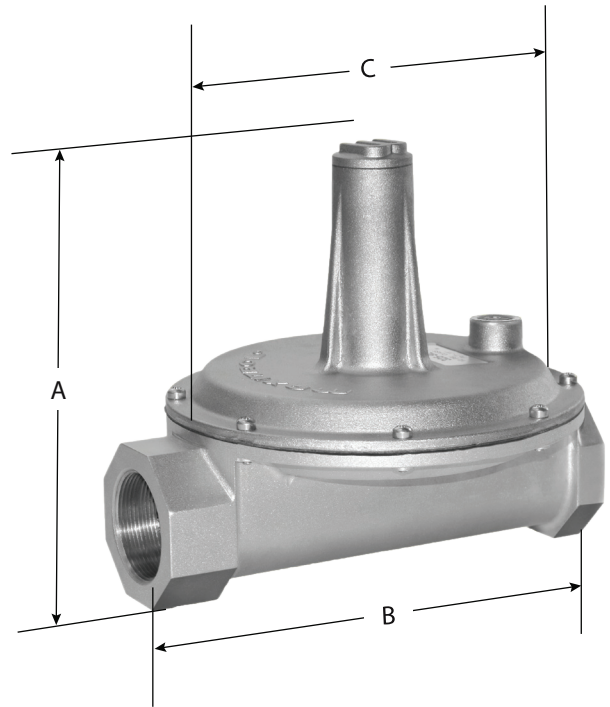

325-9

Lever Acting Design

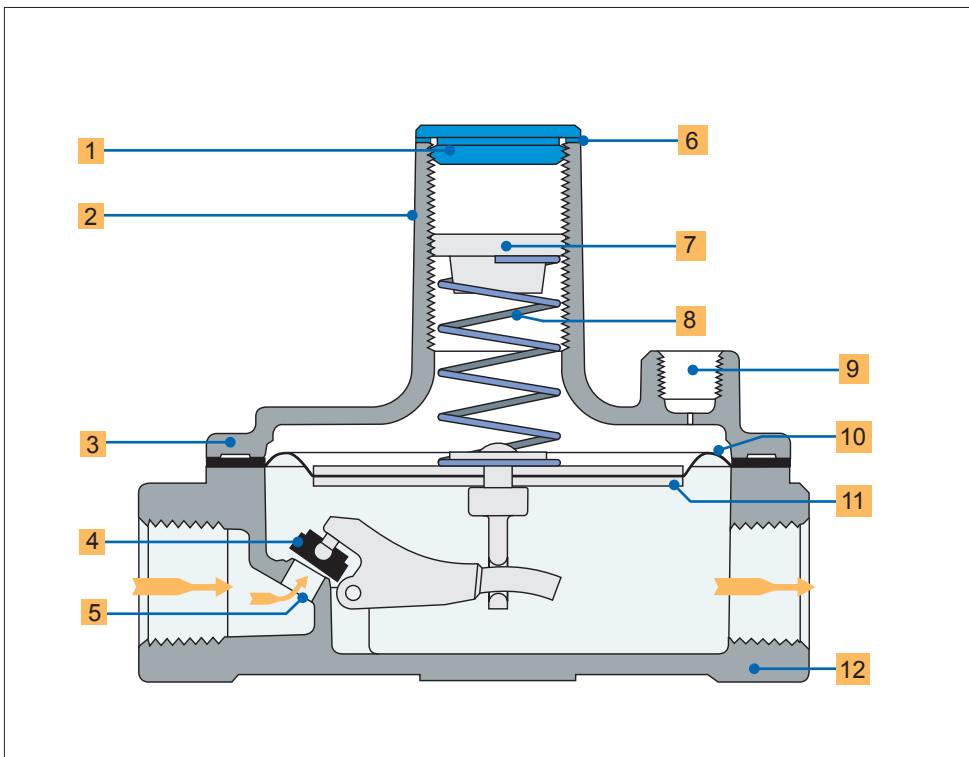

- 1 Seal Cap
- 2 Stack
- 3 Top Housing
- 4 Rubber Valve
- 5 Valve Seat
- 6 Seal Cap Gasket
- 7 Adjusting Screw
- 8 Spring
- 9 Vent Connection
- 10 Diaphragm
- 11 Diaphragm Plates
- 12 Bottom Housing

NOTE: Diagrams are graphical representations only and may differ from actual product.

R/RS SERIES

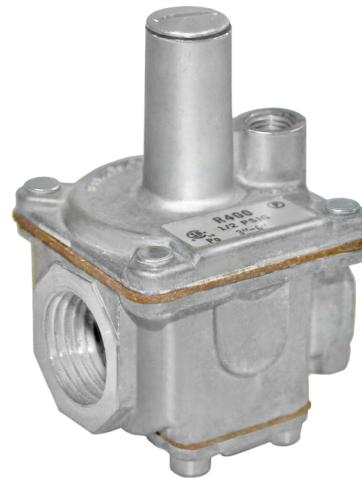

Balanced Valve Design

The R & RS series' double diaphragm balanced valve design makes it possible to maintain steady outlet pressure control with widely varying inlet pressures. The regulator is physically small yet has exceptional capacity characteristics. R & RS series regulators are intended for use with both main burner and pilot load applications. They are ideally suited for use with infrared heaters and pilot lines on large industrial heaters and boilers.



R400

Specifications

- Pipe Sizes** 3/8" to 1" threaded connections with NPT or ISO7-1 threads.
- Housing Material** R400(S), R500(S), R600(S): aluminum.
- Mounting** Suitable for multi-positional mounting. If ball check vent limiting device is installed, mount in an upright position only.
NOTE: All Maxitrol gas pressure regulators should be installed and operated in accordance with Maxitrol Safety Warning Instructions (see GPR_MI_EN.ES or GPR_CSA_MI_EN.FR).
- Certifications** R400(S), R500(S), R600(S): ANSI Z21.18/CSA 6.3 Gas Appliance Pressure Regulators.
- Gas Types** Suitable for natural, manufactured, mixed gases, liquefied petroleum gases, and LP gas-air mixtures.
- Maximum Inlet Pressure** CSA Certified: R400(S), R500(S), R600(S): 1/2 psi (3.4 kPa)
Maxitrol Tested: R400, R500, R600: 1 psi (6.9 kPa);
R400S, R500S, R600S: 5 psi (34.5 kPa)
- Emergency Exposure Limits** R400, R500, R600: 2 psi (13.8 kPa)
R400S, R500S, R600S: 12.5 psi (86.2)
- Ambient Temperature Ranges** R400(S), R500(S), R600(S): -40° to 205°F (-40° to 96°C)
- Zero Governor Models** Please refer to pages 32-37 for RZ model information.
- Minimum Regulation** Suitable for pilot flow applications.  (Circle P) (0.15 CFH NG),  (Delta P) (0.50 CFH NG).



Capacities and Pressure Drop

Capacities expressed in CFH (m³/h) @ 0.64 sp gr gas

Model	Pipe Size	Pressure Drop - inches w.c. (kPa)										
		0.2 (0.05)	0.4 (0.10)	0.6 (0.15)	0.8 (0.20)	1.0 (0.25)	1.5 (0.37)	2.0 (0.50)	2.5 (0.62)	3.0 (0.75)	3.5 (0.87)	4.0 (1.0)
R400(S)	3/8" x 3/8"	77 (2.3)	110 (3.1)	134 (3.8)	155 (4.3)	174 (4.9)	212 (5.9)	245 (6.9)	274 (7.7)	---	---	---
	1/2" x 1/2"	86 (2.4)	121 (3.4)	148 (4.1)	172 (4.82)	192 (5.4)	235 (6.6)	271 (7.6)	303 (8.5)	---	---	---
R500(S)	1/2" x 1/2"	163 (4.6)	231 (6.5)	283 (7.9)	327 (9.2)	366 (10.3)	447 (12.5)	516 (14.6)	577 (16.2)	635 (17.9)	685 (19.2)	730 (20.44)
	3/4" x 3/4"	196 (5.5)	277 (7.8)	340 (9.5)	392 (11.0)	438 (12.3)	537 (15.0)	620 (17.4)	693 (19.4)	760 (21.3)	820 (23.0)	876 (24.53)
R600(S)	3/4" x 3/4"	298 (8.3)	421 (11.8)	516 (14.5)	595 (16.7)	666 (18.7)	816 (22.9)	942 (26.4)	1054 (29.5)	1150 (32.2)	1245 (34.86)	1335 (37.38)
	1" x 1"	330 (9.2)	468 (13.1)	572 (16.2)	661 (18.2)	739 (20.7)	906 (25.4)	1046 (29.3)	1169 (32.7)	1280 (35.8)	1380 (38.64)	1480 (41.44)

NOTE: CSA maximum capacities vary with spring range and pipe size. Please contact Maxitrol directly for CSA maximums. See pages 58-59 for Regulator Sizing Requirements and Examples.

Spring Selection Chart: inches w.c. (kPa)

Model	CSA Certified Springs			Other Springs Available					
R400(S)	3 to 6 (0.75 to 1.5) Plated	---	5 to 12 (1.25 to 3) Blue	1 to 3.5 (0.25 to 0.9) Brown	2 to 5 (0.5 to 1.25) Plated	3 to 8 (0.75 to 2) Pink	4 to 12 (1 to 3) Violet	10 to 22 (2.5 to 5.5) Red	---
R500(S)	3 to 6 (0.75 to 1.5) Plated	4 to 8 (1 to 2) Orange	5 to 12 (1.25 to 3) Blue	1 to 3.5 (0.25 to 0.9) Brown	2 to 5 (0.5 to 1.25) Plated	3 to 8 (0.75 to 2) Pink	4 to 12 (1 to 3) Violet	10 to 22 (2.5 to 5.5) Red	---
R600(S)	3 to 6 (0.75 to 1.5) Plated	4 to 8 (1 to 2) Orange	5 to 12 (1.25 to 3) Blue	1 to 3.5 (0.25 to 0.9) Brown	2 to 5 (0.5 to 1.25) Plated	3 to 8 (0.75 to 2) Pink	4 to 12 (1 to 3) Violet	10 to 22 (2.5 to 5.5) Red	15 to 30 (3.7 to 7.5) Yellow

NOTE: See pages 56-57 for complete Spring Selection Chart.

R/RS SERIES

Balanced Valve Design

Dimensions

Model	Pipe Size	Vent Connection	Swing Radius	Dimensions			
				A	B	C	D
R400(S)	3/8", 1/2"	1/8" NPT	2.4" (60 mm)	3.3" (83 mm)	2" (51 mm)	2" (51 mm)	0.9" (24 mm)
R500(S)	1/2", 3/4"	1/8" NPT	3.6" (90 mm)	4.7" (119 mm)	3.1" (79 mm)	3" (76 mm)	1.2" (30 mm)
R600(S)	3/4", 1"	1/8" NPT	4.3" (110 mm)	5.7" (145 mm)	3.9" (99 mm)	4" (103 mm)	1.5" (38 mm)

NOTE: Dimensions are maximums and to be used only as an aid in designing clearance for the valve. Actual production dimensions may vary somewhat from those shown.

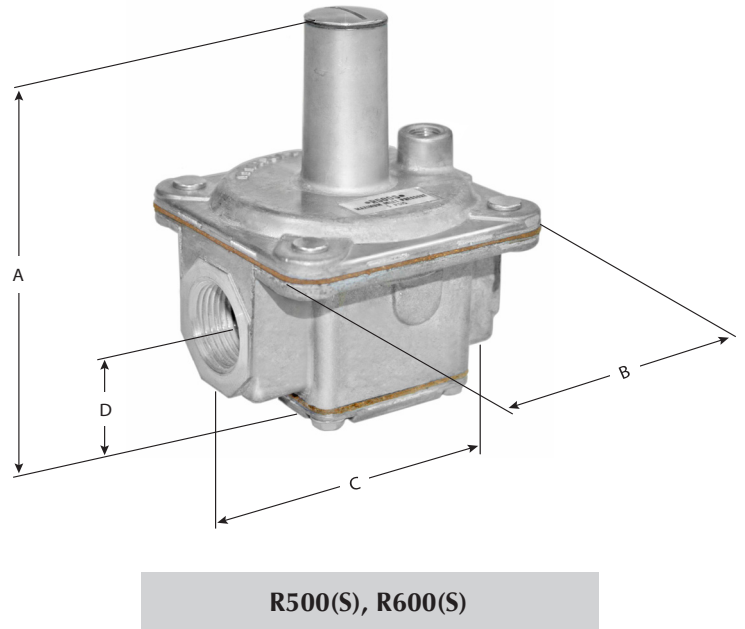
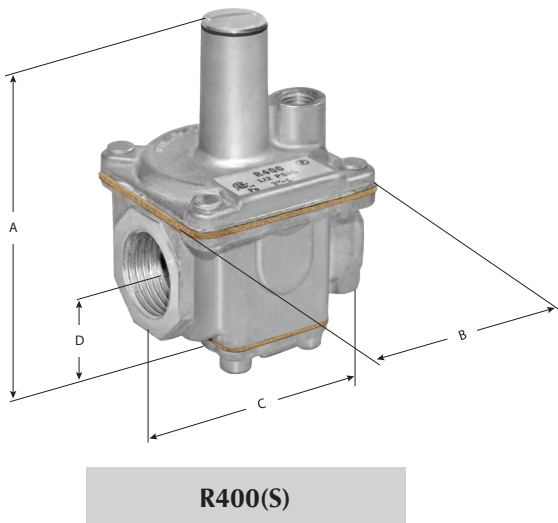

Straight-Thru-Flow Design

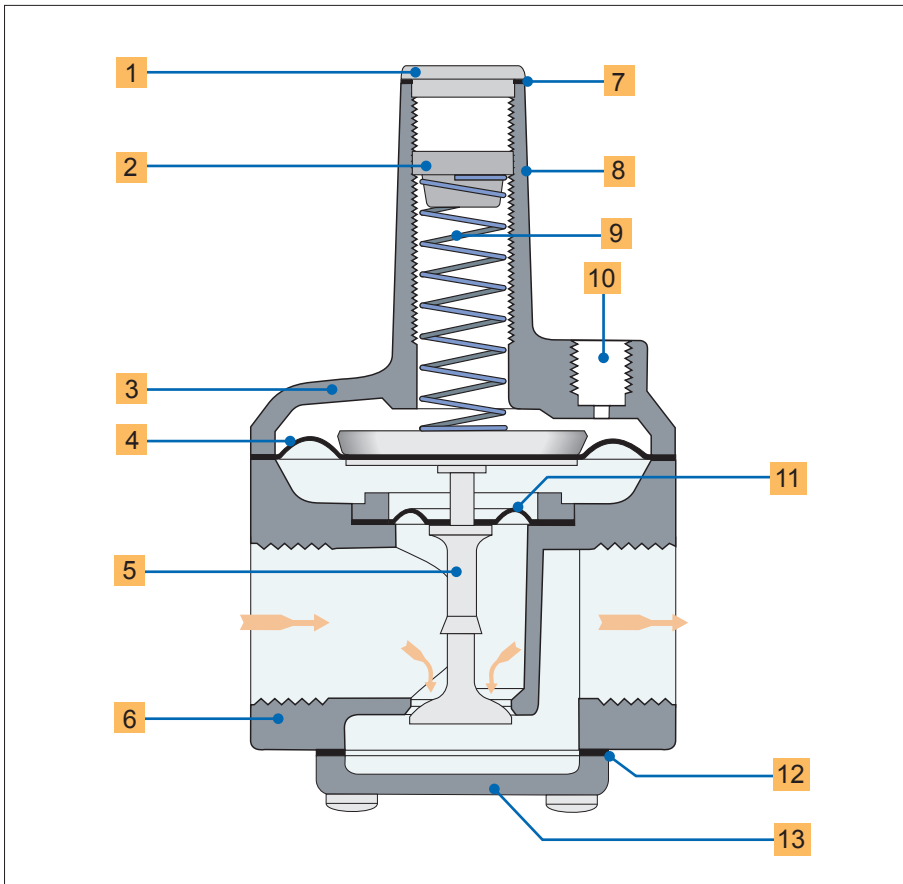

- 1** Welch Plug/Seal Cap
- 2** Vibration Resistant Adjusting Screw
- 3** Top Housing
- 4** Regulating Diaphragm
- 5** Stem & Valve
- 6** Bottom Housing
- 7** Seal Cap Gasket
- 8** Stack
- 9** Spring
- 10** Vent Connection
- 11** Balancing Diaphragm
- 12** Bottom Plate Gasket
- 13** Bottom Plate

NOTE: Diagrams are graphical representations only and may differ from actual product.

210 SERIES

Balanced Valve Design

The 210 series is a lock-up type regulator. The balanced valve design makes it possible to maintain steady outlet pressure control with widely varying inlet pressures. The regulator has an integrated dampening mechanism in the breather outlet and the sensing tube to improve regulating stability and reduce hunting tendencies. The 210 series provides precise regulation over a wide range of pressures and flow rates. Applications include gas-fired boilers, steam generators, industrial furnaces, and ovens.



210E

Specifications

- Pipe Sizes** 1" to 3" threaded connections with NPT or ISO7-1 threads. 4" 125 lb. flange (210J only).
- Housing Material** 210D, 210E, 210G, 210J: aluminum.
- Mounting** Mount in an upright position only.
NOTE: All Maxitrol gas pressure regulators should be installed and operated in accordance with Maxitrol Safety Warning Instructions (see GPR_MI_EN.ES or GPR_CSA_MI_EN.FR).
- Certifications** 210D, 210E, 210G: ANSI Z21.18/CSA 6.3 Gas Appliance Pressure Regulators.
- Gas Types** Suitable for natural, manufactured, mixed gases, liquefied petroleum gases, and LP gas-air mixtures.
- Maximum Inlet Pressure** CSA Certified: 210D, 210E, 210G: 10 psi (69 kPa)
Maxitrol Tested: 210J: 10 psi (69 kPa)
- Emergency Exposure Limits** 210D, 210E, 210G, 210J: 25 psi (172 kPa)
- Ambient Temperature Ranges** -40° to 200°F (-40° to 93°C)
- Sensing Taps** Convenient tap locations are available for downstream sensing, cross connections, and differential control. Four locations can be tapped and plugged for measuring pressure.
- Remote Sensing** 210D, 210E, 210G models may be ordered with remote sensing. The internal sensing tube is omitted and external sensing taps are provided. Add suffix letter "R" to model number when ordering.
- Zero Governor Models** Please refer to pages 32-37 for 210Z model information.
- Minimum Regulation** 210D: 25 CFH; 210G, 210E: 50 CFH; 210J: 100 CFH.



Capacities

Capacities expressed in CFH (m³/h) @ 0.64 sp gr gas

Model	Pipe Size	Inlet Pressure	Outlet Pressure - inches w.c. (kPa)								
			2.0 (0.5)	4.0 (1.0)	6.0 (1.5)	9.0 (2.25)	12 (3.0)	16 (4.0)	20 (5.0)	24 (6.0)	28 (7.0)
210D	1" x 1"	8.0" w.c.	2400 (68.0)	1900 (53.8)	1300 (36.8)	---	---	---	---	---	---
		0.5 psi	3400 (96.3)	3100 (87.8)	2700 (76.5)	2200 (62.3)	---	---	---	---	---
		0.75 psi	3500 (99.1)	4000 (113)	3800 (108)	3400 (96.3)	2900 (82.1)	2200 (62.3)	---	---	---
		1 psi	3500 (99.1)	4000 (113)	4500 (127)	4300 (122)	3900 (110)	3400 (96.3)	2700 (76.5)	1900 (53.8)	---
		1.5 psi	3500 (99.1)	4000 (113)	4500 (127)	4800 (136)	4800 (136)	5000 (142)	4600 (130)	4100 (116)	3600 (102)
		2 psi	3500 (99.1)	4000 (113)	4500 (127)	4800 (136)	4800 (136)	5000 (142)	5000 (142)	5000 (142)	5000 (142)
		3 psi	3500 (99.1)	4000 (113)	4500 (127)	4800 (136)	4800 (136)	5000 (142)	5000 (142)	5000 (142)	5000 (142)
		5 psi	3500 (99.1)	4000 (113)	4500 (127)	4800 (136)	4800 (136)	5000 (142)	5000 (142)	5000 (142)	5000 (142)
		7.5 psi	3500 (99.1)	4000 (113)	4500 (127)	4800 (136)	4800 (136)	5000 (142)	5000 (142)	5000 (142)	5000 (142)
		10 psi	3500 (99.1)	4000 (113)	4500 (127)	4800 (136)	4800 (136)	5000 (142)	5000 (142)	5000 (142)	5000 (142)

NOTE: CSA maximum capacities vary with spring range and pipe size. Please contact Maxitrol directly for CSA maximums. See pages 58-59 for Regulator Sizing Requirements and Examples.

210 SERIES

Balanced Valve Design

Capacities

Capacities expressed in CFH (m³/h) @ 0.64 sp gr gas

Model	Pipe Size	Inlet Pressure	Outlet Pressure - inches w.c. (kPa)								
			2.0 (0.5)	4.0 (1.0)	6.0 (1.5)	9.0 (2.25)	12 (3.0)	16 (4.0)	20 (5.0)	24 (6.0)	28 (7.0)
210D	1 1/4" x 1 1/4"	8.0" w.c.	3000 (84.9)	2400 (68.0)	1700 (48.1)	---	---	---	---	---	---
		0.5 psi	4000 (113)	3905 (111)	3400 (96.3)	2700 (76.5)	---	---	---	---	---
		0.75 psi	4000 (113)	5000 (142)	4700 (133)	4200 (119)	3700 (105)	2700 (76.5)	---	---	---
		1 psi	4000 (113)	5000 (142)	5000 (142)	5300 (150)	4900 (139)	4200 (119)	3400 (96.3)	2400 (68.0)	---
		1.5 psi	4000 (113)	5000 (142)	5000 (142)	6000 (170)	6000 (170)	6000 (170)	5700 (161)	5200 (147)	4600 (130)
		2 psi	4000 (113)	5000 (142)	5000 (142)	6000 (170)	6000 (170)	6000 (170)	6500 (184)	6500 (184)	6500 (184)
		3 psi	4000 (113)	5000 (142)	5000 (142)	6000 (170)	6000 (170)	6000 (170)	6500 (184)	6500 (184)	6500 (184)
		5 psi	4000 (113)	5000 (142)	5000 (142)	6000 (170)	6000 (170)	6000 (170)	6500 (184)	6500 (184)	6500 (184)
		7.5 psi	4000 (113)	5000 (142)	5000 (142)	6000 (170)	6000 (170)	6000 (170)	6500 (184)	6500 (184)	6500 (184)
10 psi	4000 (113)	5000 (142)	5000 (142)	6000 (170)	6000 (170)	6000 (170)	6500 (184)	6500 (184)	6500 (184)		

Capacities expressed in CFH (m³/h) @ 0.64 sp gr gas

Model	Pipe Size	Inlet Pressure	Outlet Pressure - inches w.c. (kPa)								
			2.0 (0.5)	4.0 (1.0)	6.0 (1.5)	9.0 (2.25)	12 (3.0)	16 (4.0)	20 (5.0)	24 (6.0)	28 (7.0)
210D	1 1/2" x 1 1/2"	8.0" w.c.	3100 (87.8)	2500 (70.8)	1800 (51.0)	---	---	---	---	---	---
		0.5 psi	4000 (113)	4000 (113)	3600 (102)	2800 (79.3)	---	---	---	---	---
		0.75 psi	4000 (113)	5000 (142)	5000 (142)	4400 (125)	3800 (108)	2800 (79.3)	---	---	---
		1 psi	4000 (113)	5000 (142)	5000 (142)	5600 (159)	5100 (144)	4400 (125)	3600 (102)	2500 (70.8)	---
		1.5 psi	4000 (113)	5000 (142)	5000 (142)	6000 (170)	6000 (170)	6500 (184)	6000 (170)	5400 (153)	4800 (136)
		2 psi	4000 (113)	5000 (142)	5000 (142)	6000 (170)	6000 (170)	6500 (184)	6500 (184)	6500 (184)	6500 (184)
		3 psi	4000 (113)	5000 (142)	5000 (142)	6000 (170)	6000 (170)	6500 (184)	6500 (184)	6500 (184)	6500 (184)
		5 psi	4000 (113)	5000 (142)	5000 (142)	6000 (170)	6000 (170)	6500 (184)	6500 (184)	6500 (184)	6500 (184)
		7.5 psi	4000 (113)	5000 (142)	5000 (142)	6000 (170)	6000 (170)	6500 (184)	6500 (184)	6500 (184)	6500 (184)
10 psi	4000 (113)	5000 (142)	5000 (142)	6000 (170)	6000 (170)	6500 (184)	6500 (184)	6500 (184)	6500 (184)		

NOTE: CSA maximum capacities vary with spring range and pipe size. Please contact Maxitrol directly for CSA maximums. See pages 58-59 for Regulator Sizing Requirements and Examples.

Capacities

Capacities expressed in CFH (m³/h) @ 0.64 sp gr gas

Model	Pipe Size	Inlet Pressure	Outlet Pressure - inches w.c. (kPa)								
			2.0 (0.5)	4.0 (1.0)	6.0 (1.5)	9.0 (2.25)	12 (3.0)	16 (4.0)	20 (5.0)	24 (6.0)	28 (7.0)
210E	1 1/2" x 1 1/2"	8.0" w.c.	4450 (126)	3650 (103)	2550 (72.2)	---	---	---	---	---	---
		0.5 psi	6300 (178)	5750 (163)	5150 (146)	4050 (115)	---	---	---	---	---
		0.75 psi	7000 (198)	7500 (212)	7050 (200)	6300 (178)	5450 (154)	4050 (115)	---	---	---
		1 psi	7000 (198)	8800 (249)	8500 (241)	7950 (225)	7250 (205)	6300 (178)	5150 (146)	3650 (103)	---
		1.5 psi	7000 (198)	8800 (249)	8800 (249)	10450 (296)	9950 (282)	9250 (262)	8550 (242)	7700 (218)	6800 (193)
		2 psi	7000 (198)	8800 (249)	8800 (249)	10500 (297)	10500 (297)	10500 (297)	10500 (297)	10250 (290)	9600 (272)
		3 psi	7000 (198)	8800 (249)	8800 (249)	10500 (297)	10500 (297)	10500 (297)	10500 (297)	10500 (297)	10500 (297)
		5 psi	7000 (198)	8800 (249)	8800 (249)	10500 (297)	10500 (297)	10500 (297)	10500 (297)	10250 (290)	10500 (297)
		7.5 psi	7000 (198)	8800 (249)	8800 (249)	10500 (297)	10500 (297)	10500 (297)	10500 (297)	10250 (290)	10500 (297)
		10 psi	7000 (198)	8800 (249)	8800 (249)	10500 (297)	10500 (297)	10500 (297)	10500 (297)	10250 (290)	10500 (297)

Capacities expressed in CFH (m³/h) @ 0.64 sp gr gas

Model	Pipe Size	Inlet Pressure	Outlet Pressure - inches w.c. (kPa)								
			2.0 (0.5)	4.0 (1.0)	6.0 (1.5)	9.0 (2.25)	12 (3.0)	16 (4.0)	20 (5.0)	24 (6.0)	28 (7.0)
210E	2" x 2"	8.0" w.c.	5150 (146)	4200 (119)	2950 (83.5)	---	---	---	---	---	---
		0.5 psi	7250 (205)	6650 (188)	5950 (168)	4700 (133)	---	---	---	---	---
		0.75 psi	8000 (226)	8650 (145)	8150 (231)	7250 (205)	6300 (178)	4700 (133)	---	---	---
		1 psi	8000 (226)	10000 (283)	9850 (279)	9150 (259)	8400 (238)	7250 (205)	5950 (168)	4200 (119)	---
		1.5 psi	8000 (226)	10000 (283)	10000 (283)	12000 (340)	11500 (326)	10700 (303)	9850 (279)	8900 (252)	7850 (222)
		2 psi	8000 (226)	10000 (283)	10000 (283)	12000 (340)	12000 (340)	12000 (340)	12000 (340)	11850 (335)	11000 (311)
		3 psi	8000 (226)	10000 (283)	10000 (283)	12000 (340)	12000 (340)	12000 (340)	12000 (340)	12000 (340)	12000 (340)
		5 psi	8000 (226)	10000 (283)	10000 (283)	12000 (340)	12000 (340)	12000 (340)	12000 (340)	12000 (340)	12000 (340)
		7.5 psi	8000 (226)	10000 (283)	10000 (283)	12000 (340)	12000 (340)	12000 (340)	12000 (340)	12000 (340)	12000 (340)
		10 psi	8000 (226)	10000 (283)	10000 (283)	12000 (340)	12000 (340)	12000 (340)	12000 (340)	12000 (340)	12000 (340)

NOTE: CSA maximum capacities vary with spring range and pipe size. Please contact Maxitrol directly for CSA maximums. See pages 58-59 for Regulator Sizing Requirements and Examples.

210 SERIES

Balanced Valve Design

Capacities

Capacities expressed in CFH (m³/h) @ 0.64 sp gr gas

Model	Pipe Size	Inlet Pressure	Outlet Pressure - inches w.c. (kPa)								
			2.0 (0.5)	4.0 (1.0)	6.0 (1.5)	9.0 (2.25)	12 (3.0)	16 (4.0)	20 (5.0)	24 (6.0)	28 (7.0)
210G	2 1/2" x 2 1/2"	8.0" w.c.	10400 (294)	8500 (241)	6000 (170)	---	---	---	---	---	---
		0.5 psi	14700 (416)	13410 (380)	12000 (340)	9500 (269)	---	---	---	---	---
		0.75 psi	16000 (453)	17500 (495)	16400 (464)	14700 (416)	12750 (361)	9500 (269)	---	---	---
		1 psi	16000 (453)	20000 (566)	19900 (563)	18500 (524)	16950 (480)	14700 (416)	12000 (340)	8500 (241)	---
		1.5 psi	16000 (453)	20000 (566)	20000 (566)	24000 (680)	23250 (658)	21600 (612)	19900 (563)	18000 (510)	15850 (449)
		2 psi	16000 (453)	20000 (566)	20000 (566)	24000 (680)	24000 (680)	24000 (680)	24000 (680)	24000 (680)	22450 (636)
		3 psi	16000 (453)	20000 (566)	20000 (566)	24000 (680)	24000 (680)	24000 (680)	24000 (680)	24000 (680)	24000 (680)
		5 psi	16000 (453)	20000 (566)	20000 (566)	24000 (680)	24000 (680)	24000 (680)	24000 (680)	24000 (680)	24000 (680)
		7.5 psi	16000 (453)	20000 (566)	20000 (566)	24000 (680)	24000 (680)	24000 (680)	24000 (680)	24000 (680)	24000 (680)
		10 psi	16000 (453)	20000 (566)	20000 (566)	24000 (680)	24000 (680)	24000 (680)	24000 (680)	24000 (680)	24000 (680)

Capacities expressed in CFH (m³/h) @ 0.64 sp gr gas

Model	Pipe Size	Inlet Pressure	Outlet Pressure - inches w.c. (kPa)								
			2.0 (0.5)	4.0 (1.0)	6.0 (1.5)	9.0 (2.25)	12 (3.0)	16 (4.0)	20 (5.0)	24 (6.0)	28 (7.0)
210G	3" x 3"	8.0" w.c.	11500 (325)	9400 (266)	6600 (187)	---	---	---	---	---	---
		0.5 psi	16000 (453)	14800 (416)	13200 (374)	10450 (296)	---	---	---	---	---
		0.75 psi	16000 (453)	19300 (546)	18100 (516)	16200 (459)	14000 (396)	10450 (296)	---	---	---
		1 psi	16000 (453)	20000 (566)	20000 (566)	20350 (576)	18700 (529)	16200 (459)	13200 (374)	9350 (265)	---
		1.5 psi	16000 (453)	20000 (566)	20000 (566)	24000 (680)	24000 (680)	23800 (674)	21900 (620)	19800 (561)	17450 (494)
		2 psi	16000 (453)	20000 (566)	20000 (566)	24000 (680)	24000 (680)	27000 (765)	27000 (765)	26400 (748)	24700 (699)
		3 psi	16000 (453)	20000 (566)	20000 (566)	24000 (680)	24000 (680)	27000 (765)	27000 (765)	27000 (765)	27000 (765)
		5 psi	16000 (453)	20000 (566)	20000 (566)	24000 (680)	24000 (680)	27000 (765)	27000 (765)	27000 (765)	27000 (765)
		7.5 psi	16000 (453)	20000 (566)	20000 (566)	24000 (680)	24000 (680)	27000 (765)	27000 (765)	27000 (765)	27000 (765)
		10 psi	16000 (453)	20000 (566)	20000 (566)	24000 (680)	24000 (680)	27000 (765)	27000 (765)	27000 (765)	27000 (765)

NOTE: CSA maximum capacities vary with spring range and pipe size. Please contact Maxitrol directly for CSA maximums. See pages 58-59 for Regulator Sizing Requirements and Examples.

Capacities

Capacities expressed in CFH (m³/h) @ 0.64 sp gr gas

Model	Pipe Size	Inlet Pressure	Outlet Pressure - inches w.c. (kPa)								
			2.0 (0.5)	4.0 (1.0)	6.0 (1.5)	9.0 (2.25)	12 (3.0)	16 (4.0)	20 (5.0)	24 (6.0)	28 (7.0)
210J	4" x 4"	8.0" w.c.	20800 (589)	17000 (481)	12000 (339)	---	---	---	---	---	---
		0.5 psi	29500 (835)	27000 (764)	24000 (680)	19000 (538)	---	---	---	---	---
		0.75 psi	32000 (906)	35000 (991)	33000 (934)	29420 (833)	25500 (722)	19000 (538)	---	---	---
		1 psi	32000 (906)	40000 (1132)	40000 (1132)	37000 (1048)	34000 (963)	29420 (833)	24000 (680)	17000 (481)	---
		1.5 psi	32000 (906)	40000 (1132)	40000 (1132)	48000 (1359)	47000 (1331)	43350 (1227)	39700 (1124)	36000 (1019)	31800 (900)
		2 psi	32000 (906)	40000 (1132)	40000 (1132)	48000 (1359)	48000 (1359)	50000 (1416)	50000 (1416)	48000 (1359)	45000 (1274)
		3 psi	32000 (906)	40000 (1132)	40000 (1132)	48000 (1359)	48000 (1359)	50000 (1416)	50000 (1416)	50000 (1416)	50000 (1416)
		5 psi	32000 (906)	40000 (1132)	40000 (1132)	48000 (1359)	48000 (1359)	50000 (1416)	50000 (1416)	50000 (1416)	50000 (1416)
		7.5 psi	32000 (906)	40000 (1132)	40000 (1132)	48000 (1359)	48000 (1359)	50000 (1416)	50000 (1416)	50000 (1416)	50000 (1416)
		10 psi	32000 (906)	40000 (1132)	40000 (1132)	48000 (1359)	48000 (1359)	50000 (1416)	50000 (1416)	50000 (1416)	50000 (1416)

NOTE: CSA maximum capacities vary with spring range and pipe size. Please contact Maxitrol directly for CSA maximums. See pages 58-59 for Regulator Sizing Requirements and Examples.

210 SERIES

Balanced Valve Design

Pressure Drop: inches w.c. (kPa)

Flow Rate CFH (m ³ /h)	210D			210E		210G		210J
	1"	1 1/4"	1 1/2"	1 1/2"	2"	2 1/2"	3"	4"
500 (14.2)	0.23 (0.06)	0.15 (0.04)	0.14 (0.03)	---	---	---	---	---
1000 (28.3)	0.92 (0.23)	0.59 (0.15)	0.54 (0.13)	0.27 (0.07)	0.20 (0.05)	0.05 (0.01)	0.04 (0.009)	0.01 (0.002)
1500 (42.5)	2.08 (0.52)	1.33 (0.33)	1.22 (0.30)	---	---	---	---	---
2000 (56.6)	3.07 (0.76)	2.37 (0.59)	2.16 (0.54)	1.09 (0.27)	0.82 (0.20)	0.20 (0.05)	0.17 (0.04)	0.05 (0.01)
2500 (70.8)	5.78 (1.44)	3.70 (0.92)	3.38 (0.84)	---	---	---	---	---
3000 (85.0)	8.32 (2.07)	5.33 (1.33)	4.87 (1.21)	2.46 (0.61)	1.84 (0.46)	0.45 (0.11)	0.37 (0.09)	0.12 (0.03)
3500 (99.1)	11.33 (2.82)	7.25 (1.81)	6.62 (1.65)	---	---	---	---	---
4000 (113)	14.79 (3.68)	9.47 (2.36)	8.65 (2.15)	4.37 (1.09)	3.28 (0.82)	0.80 (0.20)	0.66 (0.16)	0.21 (0.05)
4500 (127)	18.72 (4.66)	11.98 (2.98)	10.95 (2.73)	---	---	---	---	---
5000 (142)	23.11 (5.76)	14.79 (3.68)	13.52 (3.37)	6.82 (1.70)	5.12 (1.28)	1.25 (0.31)	1.03 (0.26)	0.34 (0.08)
5500 (156)	27.97 (6.97)	17.90 (4.46)	16.35 (4.07)	---	---	---	---	---
6000 (170)	33.28 (8.29)	21.30 (5.30)	19.46 (4.85)	9.82 (2.45)	7.37 (1.84)	1.80 (0.45)	1.48 (0.37)	0.49 (0.12)
6500 (184)	---	25.00 (6.23)	22.84 (5.69)	---	---	---	---	---
7000 (198)	---	28.99 (7.22)	26.49 (6.60)	13.36 (3.33)	10.05 (2.50)	2.45 (0.61)	2.02 (0.50)	0.66 (0.16)
7500 (212)	---	---	30.41 (7.57)	---	---	---	---	---
8000 (226)	---	---	---	17.45 (4.35)	13.10 (3.26)	3.20 (0.80)	2.64 (0.66)	0.87 (0.22)
8500 (241)	---	---	---	---	---	---	---	---
9000 (255)	---	---	---	22.10 (5.50)	16.60 (4.13)	4.05 (1.01)	3.35 (0.83)	1.10 (0.27)
9500 (269)	---	---	---	---	---	---	---	---
10000 (283)	---	---	---	27.30 (6.80)	20.50 (5.11)	5.00 (1.24)	4.15 (1.03)	1.35 (0.34)
11000 (311)	---	---	---	33.00 (8.22)	24.80 (6.18)	6.05 (1.51)	5.00 (1.24)	---
12000 (340)	---	---	---	39.30 (9.79)	29.50 (7.35)	7.20 (1.79)	5.95 (1.48)	1.95 (0.48)
13000 (368)	---	---	---	---	34.60 (8.62)	8.50 (2.12)	7.00 (1.74)	---
14000 (369)	---	---	---	---	40.15 (10.00)	9.85 (2.45)	8.10 (2.01)	2.68 (0.67)
15000 (425)	---	---	---	---	---	11.30 (2.81)	9.30 (2.32)	---
16000 (453)	---	---	---	---	---	12.85 (3.20)	10.60 (2.64)	3.47 (0.86)
17000 (481)	---	---	---	---	---	14.50 (3.61)	11.95 (2.98)	---
18000 (510)	---	---	---	---	---	16.25 (4.05)	13.40 (3.34)	4.40 (1.09)
19000 (538)	---	---	---	---	---	18.10 (4.51)	14.90 (3.71)	---
20000 (566)	---	---	---	---	---	20.05 (4.99)	16.50 (4.11)	5.42 (1.35)
22000 (623)	---	---	---	---	---	24.25 (6.40)	20.00 (4.98)	6.56 (1.63)
24000 (680)	---	---	---	---	---	28.85 (7.19)	23.80 (5.93)	7.81 (1.94)
26000 (736)	---	---	---	---	---	33.85 (8.43)	27.90 (6.95)	9.06 (2.26)
28000 (793)	---	---	---	---	---	39.25 (9.78)	32.40 (8.07)	10.62 (2.64)
30000 (849)	---	---	---	---	---	---	37.20 (9.27)	12.41 (3.09)
32000 (906)	---	---	---	---	---	---	---	13.90 (3.46)
34000 (963)	---	---	---	---	---	---	---	15.69 (3.91)
36000 (1019)	---	---	---	---	---	---	---	17.60 (4.38)
38000 (1076)	---	---	---	---	---	---	---	19.60 (4.88)
40000 (1133)	---	---	---	---	---	---	---	21.70 (5.40)
45000 (1274)	---	---	---	---	---	---	---	27.40 (6.82)
50000 (1416)	---	---	---	---	---	---	---	33.80 (8.42)
55000 (1557)	---	---	---	---	---	---	---	41.00 (10.21)

NOTE: The minimum capacities for the different models listed on the capacity charts and represented by the heavy line on the pressure drop are values at which these controls have been certified by CSA (except for the 210J). See pages 58-59 for Regulator Sizing Requirements and Examples.

Spring Selection Chart: inches w.c. (kPa)

Model	CSA Certified Springs										Other Springs
	1 to 3.5 (0.25 to 0.9) Brown	2 to 5 (0.5 to 1.25) Plated	3 to 6 (0.75 to 1.5) Plated	3 to 8 (0.75 to 2) Pink	4 to 8 (1 to 2) Orange	4 to 12 (1 to 3) Violet	5 to 12 (1.25 to 3) Blue	5 to 15 (1.25 to 3.7) Green	10 to 22 (2.5 to 5.5) Red	15 to 30 (3.7 to 7.5) Yellow	
210D	1 to 3.5 (0.25 to 0.9) Brown	2 to 5 (0.5 to 1.25) Plated	3 to 6 (0.75 to 1.5) Plated	3 to 8 (0.75 to 2) Pink	4 to 8 (1 to 2) Orange	4 to 12 (1 to 3) Violet	5 to 12 (1.25 to 3) Blue	5 to 15 (1.25 to 3.7) Green	10 to 22 (2.5 to 5.5) Red	15 to 30 (3.7 to 7.5) Yellow	20 to 42 (5 to 10.5) Black
210E	1 to 3.5 (0.25 to 0.9) Brown	2 to 5 (0.5 to 1.25) Plated	3 to 6 (0.75 to 1.5) Plated	3 to 8 (0.75 to 2) Pink	4 to 8 (1 to 2) Orange	4 to 12 (1 to 3) Violet	5 to 12 (1.25 to 3) Blue	5 to 15 (1.25 to 3.7) Green	10 to 22 (2.5 to 5.5) Red	15 to 30 (3.7 to 7.5) Yellow	20 to 42 (5 to 10.5) Black
210G	1 to 3.5 (0.25 to 0.9) Brown	2 to 5 (0.5 to 1.25) Plated	3 to 6 (0.75 to 1.5) Plated	3 to 8 (0.75 to 2) Pink	4 to 8 (1 to 2) Orange	4 to 12 (1 to 3) Violet	5 to 12 (1.25 to 3) Blue	5 to 15 (1.25 to 3.7) Green	10 to 22 (2.5 to 5.5) Red	15 to 30 (3.7 to 7.5) Yellow	20 to 42 (5 to 10.5) Black
210J	---	2 to 5 (0.5 to 1.25) Plated	3 to 6 (0.75 to 1.5) Plated	3 to 8 (0.75 to 2) Pink	---	4 to 12 (1 to 3) Violet	5 to 12 (1.25 to 3) Blue	---	10 to 22 (2.5 to 5.5) Red	15 to 30 (3.7 to 7.5) Yellow	20 to 42 (5 to 10.5) Black

NOTE: The area within the heavy line indicates CSA certified springs. See pages 56-57 for complete Spring Selection Chart.

210 SERIES

Balanced Valve Design

Dimensions

Model	Pipe Size	Vent Connection	Swing Radius	Dimensions			
				A	B	C	D
210D	1", 1 1/4", 1 1/2"	1/2" NPT	5.4" (138 mm)	9" (228 mm)	7" (178 mm)	5.5" (140 mm)	2.4" (62 mm)
210E	1 1/2", 2"	3/4" NPT	8.3" (211 mm)	11.3" (286)	9.1" (232 mm)	7.6" (194 mm)	2.3" (59 mm)
210G	2 1/2", 3"	3/4" NPT	11.9" (302 mm)	16.1" (408 mm)	13.4" (341 mm)	10.4" (264 mm)	4.3" (107 mm)
210J	4"	3/4" NPT	18" (457 mm)	24.3" (616 mm)	18" (457 mm)	13.3" (349 mm)	5.4" (138 mm)

NOTE: Dimensions are maximums and to be used only as an aid in designing clearance for the valve. Actual production dimensions may vary somewhat from those shown.

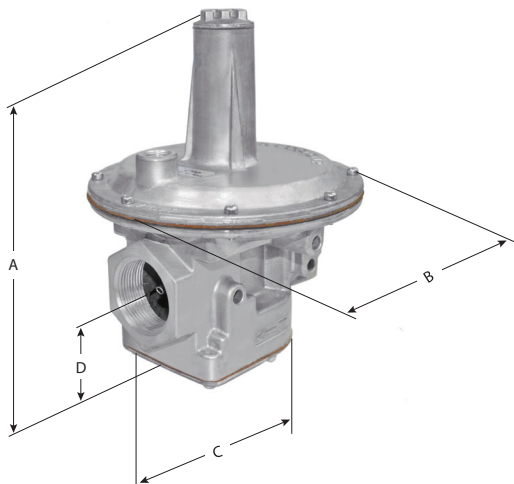

210D, 210E, 210G

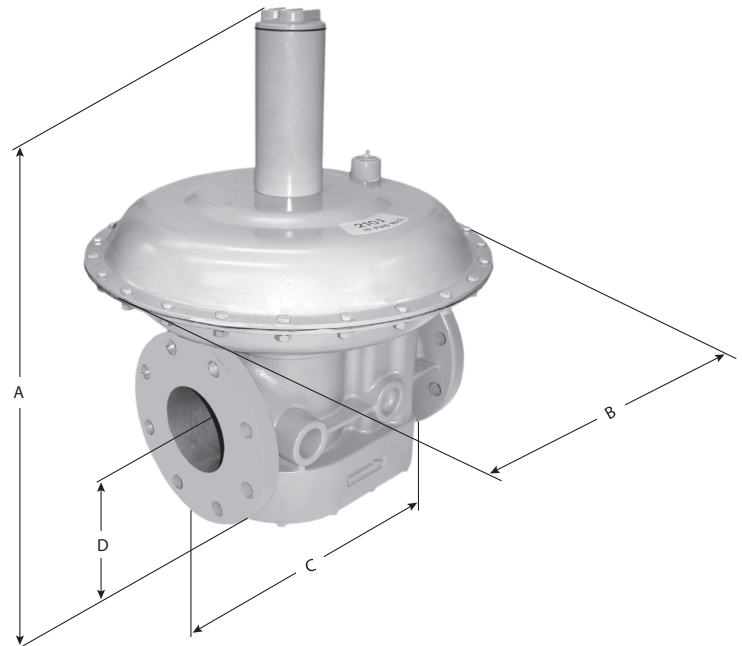

210J

210 Balanced Valve Design

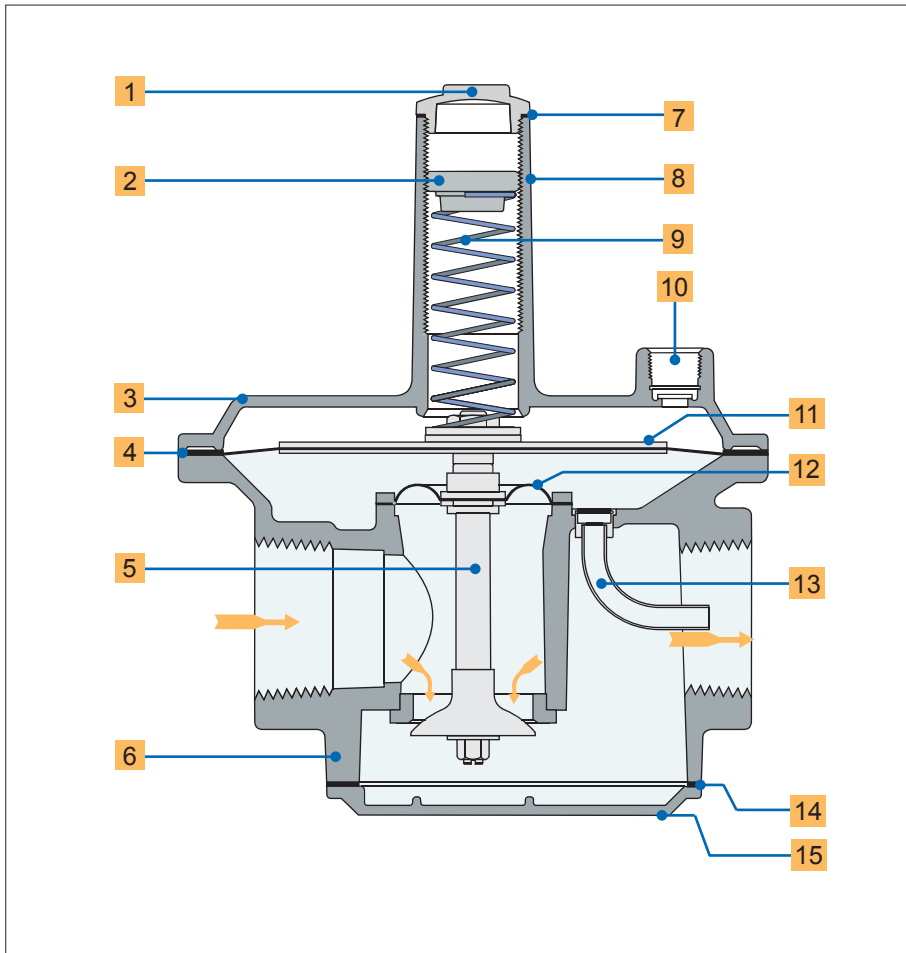

- 1 Welch Plug/Seal Cap
- 2 Vibration Resistant Adjusting Screw
- 3 Top Housing
- 4 Regulating Diaphragm
- 5 Stem & Valve
- 6 Bottom Housing
- 7 Seal Cap Gasket
- 8 Stack
- 9 Spring
- 10 Vent Connection
- 11 Diaphragm Plates
- 12 Balancing Diaphragm
- 13 Sensing Tube
- 14 Bottom Plate Gasket
- 15 Bottom Plate

NOTE: Diagrams are graphical representations only and may differ from actual product.

RZ and 210Z

Zero Governor Design

Both the RZ and 210Z series are adaptable for air-gas mixing applications. Because of the balanced valve construction, Z models offer superior performance at an economic price to other types of atmospheric regulators.

Maxitrol's RZ and 210Z Zero Governor model regulators are used for flow control of burners, nozzle mixers, mixing tees and proportional premixers.



210EZ

Specifications

Pipe Sizes	RZ Models: 3/8" to 1" threaded connections with NPT or ISO7-1 threads. 210Z Models: 1" to 3" threaded connections with NPT or ISO7-1 threads. 4" 125 lb. flange (210JZ only).
Housing Material	R400Z, R500Z, R600Z, 210DZ, 210EZ, 210GZ, 210JZ: aluminum.
Mounting	R400Z, 210DZ, 210EZ, 210GZ, 210JZ mount in an upright position only. R500Z, R600Z suitable for multi-positional mounting. If ball check vent limiting device is installed, mount in an upright position only. NOTE: All Maxitrol gas pressure regulators should be installed and operated in accordance with Maxitrol Safety Warning Instructions (see GPR_MI_EN.ES or GPR_CSA_MI_EN.FR).
Certifications	R400Z, R500Z, 210DZ, 210EZ, 210GZ: ANSI Z21.18/CSA 6.3 Gas Appliance Pressure Regulators.
Gas Types	Suitable for natural, manufactured, mixed gases, liquefied petroleum gases, and LP gas-air mixtures.
Maximum Inlet Pressure	CSA Certified: R400Z, R500Z: 1/2 psi (3.4 kPa); 210DZ, 210EZ, 210GZ: 5 psi (34.5 kPa) Maxitrol Tested: R600Z: 1/2 psi (3.4 kPa); 210JZ: 5 psi (34.5)
Emergency Exposure Limits	R400Z, R500Z, R600Z: 2 psi (13.8 kPa) 210DZ, 210EZ, 210GZ, 210JZ: 25 psi (172 kPa)
Ambient Temperature Ranges	R400Z, R500Z, R600Z: -40° to 205°F (-40° to 96°C) 210DZ, 210EZ, 210GZ, 210JZ: -40° to 200°F (-40° to 93°C)
Sensing Taps	210Z Models have convenient tap locations available for downstream sensing, cross connections, and differential control. Four locations can be tapped and plugged for measuring pressure.
Remote Sensing	210DZ, 210EZ, 210GZ models may be ordered with remote sensing. The internal sensing tube is omitted and external sensing taps are provided. Add suffix letter "R" to model number when ordering.
Minimum Regulation	R400Z: Suitable for pilot flow applications. (P) (Circle P) (0.15 CFH NG), (Δ) (Delta P) (0.50 CFH NG). R500Z, R600Z: 10 CFH.



Capacities and Pressure Drop

Capacities expressed in CFH (m³/h) @ 0.64 sp gr gas

Model Number	Pipe Size	Pressure Drop - inches w.c. (kPa)										
		0.2 (0.05)	0.4 (0.10)	0.6 (0.15)	0.8 (0.20)	1.0 (0.25)	1.5 (0.37)	2.0 (0.50)	2.5 (0.62)	3.0 (0.75)	3.5 (0.87)	4.0 (1.0)
R400Z	3/8" x 3/8"	77 (2.16)	110 (3.08)	134 (3.75)	155 (4.34)	174 (4.87)	212 (5.94)	245 (6.86)	274 (7.67)	--	--	--
	1/2" x 1/2"	86 (2.41)	121 (3.39)	148 (4.14)	172 (4.82)	192 (5.38)	235 (6.58)	271 (7.59)	303 (8.48)	--	--	--
R500Z	1/2" x 1/2"	163 (4.56)	231 (6.47)	283 (7.92)	327 (9.16)	366 (10.3)	447 (12.5)	516 (14.6)	577 (16.2)	635 (17.8)	685 (19.2)	730 (20.4)
	3/4" x 3/4"	196 (5.49)	277 (7.76)	340 (9.52)	392 (11.0)	438 (12.3)	537 (15.0)	620 (17.4)	693 (19.4)	760 (21.3)	820 (22.7)	876 (24.5)
R600Z	3/4" x 3/4"	298 (8.34)	421 (11.8)	516 (14.5)	595 (16.7)	666 (18.7)	816 (22.9)	942 (26.4)	1054 (29.5)	1150 (32.2)	1245 (34.9)	1335 (37.4)
	1" x 1"	330 (9.24)	468 (13.1)	572 (16.0)	661 (18.2)	739 (20.7)	906 (25.4)	1046 (29.3)	1169 (32.7)	1280 (35.8)	1380 (38.6)	1480 (41.4)

NOTE: CSA maximum capacities vary with spring range and pipe size. Please contact Maxitrol directly for CSA maximums. See pages 58-59 for Regulator Sizing Requirements and Examples.

RZ and 210Z

Zero Governor Design

Capacities and Pressure Drop

Capacities expressed in CFH (m³/h) @ 0.64 sp gr gas

Model Number	Pipe Size	Pressure Drop - inches w.c. (kPa) unless noted										
		0.1 (0.025)	0.3 (0.075)	0.5 (0.125)	1.0 (0.25)	3.0 (0.75)	5.0 (1.25)	7.0 (1.74)	0.5 psi (3.45)	0.75 psi (5.17)	1 psi (6.89)	1.5 psi (10.34)
210DZ	1" x 1"	--	--	--	900 (25.2)	1600 (44.8)	2000 (56.0)	2400 (67.2)	3300 (92.4)	4100 (115)	4750 (133)	5800 (162)
	1 1/4" x 1 1/4"	--	--	--	1100 (30.8)	1900 (53.2)	2500 (70.0)	2900 (81.2)	4100 (115)	5000 (140)	5850 (164)	7150 (200)
	1 1/2" x 1 1/2"	--	--	--	1200 (33.6)	2100 (58.8)	2700 (75.6)	3200 (89.6)	4500 (126)	5500 (154)	6350 (176)	7750 (217)
210EZ	1 1/2" x 1 1/2"	--	1050 (29.4)	1350 (37.8)	1915 (53.6)	3315 (92.8)	4280 (120)	5065 (142)	7125 (199)	8725 (244)	10075 (282)	12340 (345)
	2" x 2"	--	1210 (33.9)	1560 (43.7)	2210 (61.9)	3825 (107)	4940 (139)	5845 (164)	8225 (230)	10070 (282)	11630 (326)	14245 (399)
210GZ	2 1/2" x 2 1/2"	1410 (39.5)	2450 (68.6)	3160 (88.5)	4470 (125)	7740 (217)	9995 (280)	11825 (331)	16635 (466)	20370 (570)	23525 (659)	28810 (807)
	3" x 3"	1555 (43.5)	2695 (75.5)	3475 (97.3)	4920 (138)	8520 (239)	11000 (308)	13020 (365)	18310 (513)	22425 (628)	25890 (725)	31710 (888)
210JZ	4" x 4"	2700 (75.6)	4700 (132)	6000 (168)	8600 (241)	15000 (420)	19000 (532)	23000 (644)	32000 (896)	40000 (1120)	45500 (1274)	55700 (1560)

NOTE: CSA maximum capacities vary with spring range and pipe size. Please contact Maxitrol directly for CSA maximums. See pages 58-59 for Regulator Sizing Requirements and Examples.

Spring Selection: inches w.c (kPa)

Model	Outlet Pressure Range
R400Z	-1.5 to 1.0 (-0.37 to 0.25)
R500Z	-1.0 to 2.5 (-0.25 to 0.62)
R600Z	-1.0 to 1.5 (-0.25 to 0.37)

Model	Outlet Pressure Range
210DZ	-1.0 to 1.5 (-0.25 to 0.37)
210EZ	-1.0 to 1.5 (-0.25 to 0.37)
210GZ	-1.0 to 1.5 (-0.25 to 0.37)
210JZ	-1.0 to 1.5 (-0.25 to 0.37)

NOTE: See pages 56-57 for complete Spring Selection Chart.

RZ and 210Z

Zero Governor Design

Dimensions

Model	Pipe Size	Vent Connection	Swing Radius	Dimensions			
				A	B	C	D
R400Z	3/8", 1/2"	1/8" NPT	2.4" (60 mm)	3.3" (83 mm)	2" (51 mm)	2" (51 mm)	0.9" (24 mm)
R500Z	1/2", 3/4"	1/8" NPT	3.6" (90 mm)	4.7" (119 mm)	3.1" (79 mm)	3" (79 mm)	1.2" (30 mm)
R600Z	3/4", 1"	1/8" NPT	4.3" (109 mm)	5.7" (144 mm)	3.9" (98 mm)	4" (102 mm)	1.5" (37 mm)
210DZ	1", 1 1/4", 1 1/2"	1/2" NPT	5.4" (138 mm)	9" (229 mm)	7" (178 mm)	6" (152 mm)	2.4" (60 mm)
210EZ	1 1/2", 2"	3/4" NPT	8.3" (211 mm)	11.3" (286 mm)	9.1" (232 mm)	8" (203 mm)	2.9" (75 mm)
210GZ	2 1/2", 3"	3/4" NPT	11.9" (302 mm)	16.5" (419 mm)	13.5" (343 mm)	11.8" (138 mm)	4.6" (116 mm)
210JZ	4"	3/4" NPT	18.4" (467 mm)	24.3" (616 mm)	18" (457 mm)	13.8" (349 mm)	5.4" (138 mm)

NOTE: Dimensions are maximums and to be used only as an aid in designing clearance for the valve.
Actual production dimensions may vary somewhat from those shown.

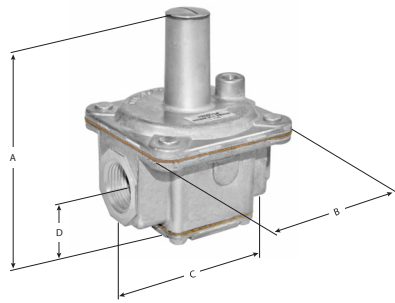

R400Z, R500Z, R600Z

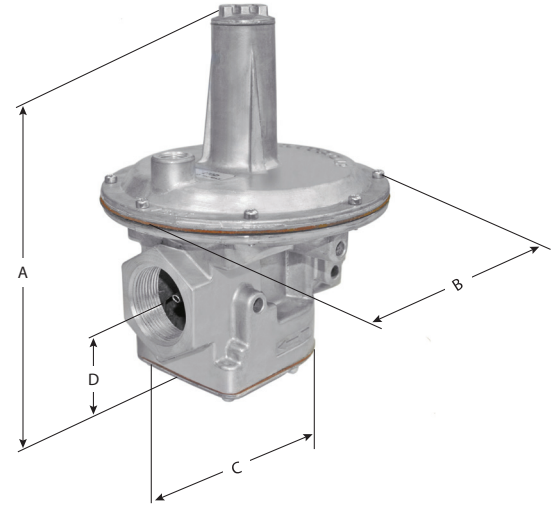

210DZ, 210EZ, 210GZ

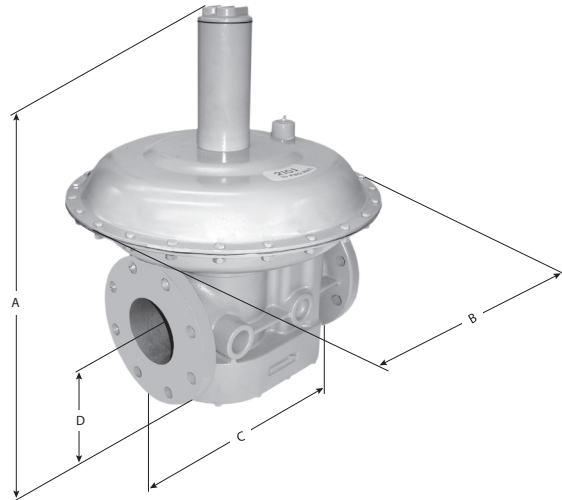

210JZ

Zero Governor Design

R400Z, R500Z, R600Z

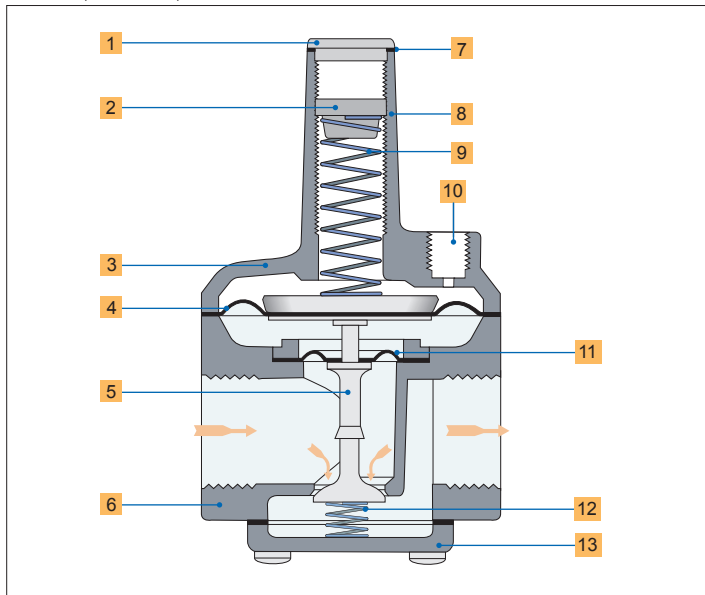

- 1 Seal Cap
- 2 Adjusting Screw
- 3 Top Housing
- 4 Regulating Diaphragm
- 5 Stem & Valve
- 6 Bottom Housing
- 7 Seal Cap Gasket
- 8 Stack
- 9 Spring
- 10 Vent Connection
- 11 Balancing Diaphragm
- 12 Counter Spring
- 13 Bottom Plate

210DZ, 210EZ, 210GZ, 210JZ

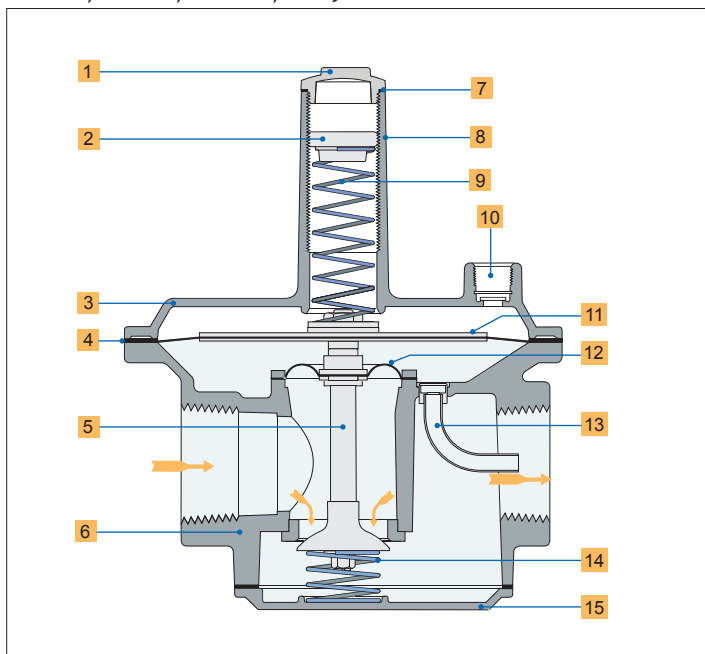

- 1 Seal Cap
- 2 Adjusting Screw
- 3 Top Housing
- 4 Regulating Diaphragm
- 5 Stem & Valve
- 6 Bottom Housing
- 7 Seal Cap Gasket
- 8 Stack
- 9 Spring
- 10 Vent Connection
- 11 Diaphragm Plates
- 12 Balancing Diaphragm
- 13 Sensing Tube
- 14 Counter Spring
- 15 Bottom Plate

NOTE: Diagrams are graphical representations only and may differ from actual product.

220 SERIES

Pilot Loaded Design

The 220 series uses a servo-operated design rather than a spring-loaded design and can deliver higher outlet pressures than the conventional spring-loaded models.

The main diaphragm of the model 220 is loaded with gas pressure instead of a spring. A small pilot regulator located in the upper housing precisely controls this gas pressure. When the regulated outlet pressure of the servo regulator is changed by spring adjustment, the outlet pressure of the main 220 regulator will be changed proportionately.



220 D

Specifications

Pipe Sizes 1" to 3" threaded connections with NPT or ISO7-1 threads. 4" 125 lb. flange (220J) only.

Housing Material 220D, 220E, 220G, 220J: aluminum.

Mounting Mount in an upright position only.

NOTE: All Maxitrol gas pressure regulators should be installed and operated in accordance with Maxitrol Safety Warning Instructions (see GPR_MI_EN.ES).

Gas Types Suitable for natural, manufactured, mixed gases, liquefied petroleum gases, and LP gas-air mixtures.

Maximum Inlet Pressure 10 psi (68.9 kPa)

Flow Rates up to 50,000 CFH (1416 m³/h)

Emergency Exposure Limits 25 psi (170 kPa)

Ambient Temperature Ranges -40 to 200°F (-40 to 93°C)

Sensing Taps Three positions can be tapped and plugged for measuring pressure. The fourth position is used to supply inlet pressure to the pilot regulator.

Remote Sensing 220D, 220E, 220G models may be ordered with remote sensing. The internal sensing tube is omitted and external sensing taps are provided. Add suffix letter "R" to model number when ordering.

NOTE: 220D, 220E, 220G, 220J are not CSA certified.

NOTE: "L" models available for outlet pressures under 1 psi (6.9 kPa).

Pressure Drop: inches w.c. (kPa) @ 0.64 sp gr gas

Flow Rate CFH (m ³ /h)	220D			220E		220G		220J
	1"	1 1/4"	1 1/2"	1 1/2"	2"	2 1/2"	3"	4"
1000 (28.3)	1.90 (0.47)	1.70 (0.42)	1.70 (0.42)	---	---	---	---	---
2000 (56.6)	4.93 (1.23)	3.10 (0.77)	2.90 (0.72)	1.90 (0.47)	1.90 (0.47)	---	---	---
3000 (85.0)	11.10 (2.76)	7.42 (1.85)	5.40 (1.34)	2.90 (0.72)	2.40 (0.60)	---	---	---
4000 (113)	19.70 (4.91)	13.20 (3.29)	11.10 (2.76)	4.93 (1.23)	4.00 (1.00)	2.00 (0.50)	1.90 (0.47)	1.70 (0.42)
5000 (142)	30.80 (7.67)	20.70 (5.16)	17.40 (4.33)	7.70 (1.92)	6.25 (1.56)	2.20 (0.55)	2.10 (0.52)	1.70 (0.42)
6000 (170)	44.20 (11.01)	29.70 (7.40)	25.00 (6.23)	11.10 (2.76)	9.00 (2.24)	2.60 (0.65)	2.30 (0.57)	1.70 (0.42)
7000 (198)	---	40.60 (10.11)	34.00 (8.47)	15.10 (3.76)	12.25 (3.05)	3.00 (0.75)	2.60 (0.65)	1.70 (0.42)
8000 (226)	---	---	44.50 (11.08)	19.70 (4.91)	16.00 (3.98)	4.00 (1.00)	3.00 (0.75)	1.80 (0.45)
9000 (255)	---	---	---	24.90 (6.20)	20.25 (5.04)	5.00 (1.25)	3.80 (0.95)	1.90 (0.47)
10000 (283)	---	---	---	30.80 (7.67)	25.00 (6.23)	6.22 (1.55)	4.60 (1.15)	2.10 (0.52)
12000 (340)	---	---	---	44.20 (11.01)	36.00 (8.97)	9.00 (2.24)	6.80 (1.69)	2.40 (0.60)
14000 (369)	---	---	---	---	---	12.20 (3.04)	9.30 (2.32)	2.80 (0.70)
16000 (453)	---	---	---	---	---	16.00 (4.00)	12.10 (3.01)	3.40 (0.85)
18000 (510)	---	---	---	---	---	20.20 (5.03)	15.30 (3.81)	4.40 (1.10)
20000 (566)	---	---	---	---	---	25.00 (6.23)	18.90 (4.71)	5.40 (1.35)
25000 (708)	---	---	---	---	---	40.60 (10.11)	30.70 (7.65)	8.90 (2.22)
30000 (849)	---	---	---	---	---	---	42.50 (10.59)	12.40 (3.09)
35000 (991)	---	---	---	---	---	---	---	17.05 (4.25)
40000 (1133)	---	---	---	---	---	---	---	21.70 (5.41)
45000 (1274)	---	---	---	---	---	---	---	27.40 (6.83)
50000 (1416)	---	---	---	---	---	---	---	33.80 (8.42)
55000 (1557)	---	---	---	---	---	---	---	41.00 (10.21)

NOTE: Do not exceed 36" pressure drop when determining acceptable capacities at which these controls may be used. Under some conditions, these limits may be surpassed, but only after consultation with Maxitrol. See pages 58-59 for Regulator Sizing Requirements and Examples.

Spring Selection

Model	Available Springs	
220D	1 psi to 3 psi (6.9 kPa to 20.7 kPa) Tagged	2 psi to 5 psi (13.8 kPa to 34.5 kPa) Tagged
220E	1 psi to 3 psi (6.9 kPa to 20.7 kPa) Tagged	2 psi to 5 psi (13.8 kPa to 34.5 kPa) Tagged
220G	1 psi to 3 psi (6.9 kPa to 20.7 kPa) Tagged	2 psi to 5 psi (13.8 kPa to 34.5 kPa) Tagged
220J	1 psi to 3 psi (6.9 kPa to 20.7 kPa) Tagged	2 psi to 5 psi (13.8 kPa to 34.5 kPa) Tagged

NOTE: See pages 56-57 for complete Spring Selection Chart.

220 SERIES

Pilot Loaded Design

Dimensions

Model	Pipe Size	Vent Connection	Swing Radius	Dimensions			
				A	B	C	D
220D	1", 1 1/4", 1 1/2"	12A06 vent limiting device installed.	8.1" (206 mm)	9.5" (241 mm)	7" (178 mm)	5.5" (140 mm)	8.3" (210 mm)
220E	1 1/2", 2"	12A06 vent limiting device installed.	8.6" (217 mm)	11.2" (285 mm)	9.1" (232 mm)	7.6" (194 mm)	10" (256 mm)
220G	2 1/2", 3"	12A06 vent limiting device installed.	10.4" (264 mm)	14.2" (362 mm)	13.5" (343 mm)	10.4" (264 mm)	15.8" (400 mm)
220J	4"	12A06 vent limiting device installed.	—	20.5" (520 mm)	18" (457 mm)	13.9" (352 mm)	20" (508 mm)

NOTE: Dimensions are maximums and to be used only as an aid in designing clearance for the valve. Actual production dimensions may vary somewhat from those shown.

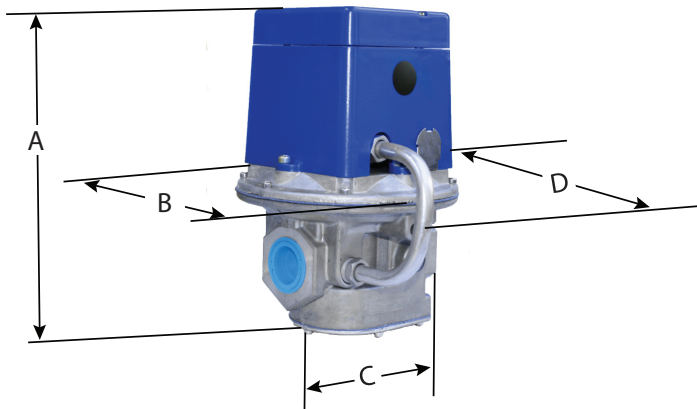

220D, 220E, 220G

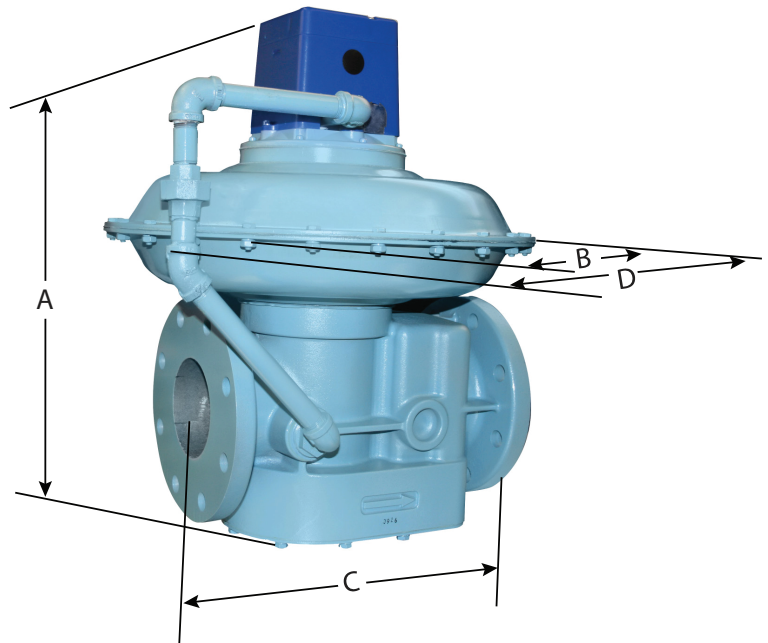

220J

Pilot Loaded Design

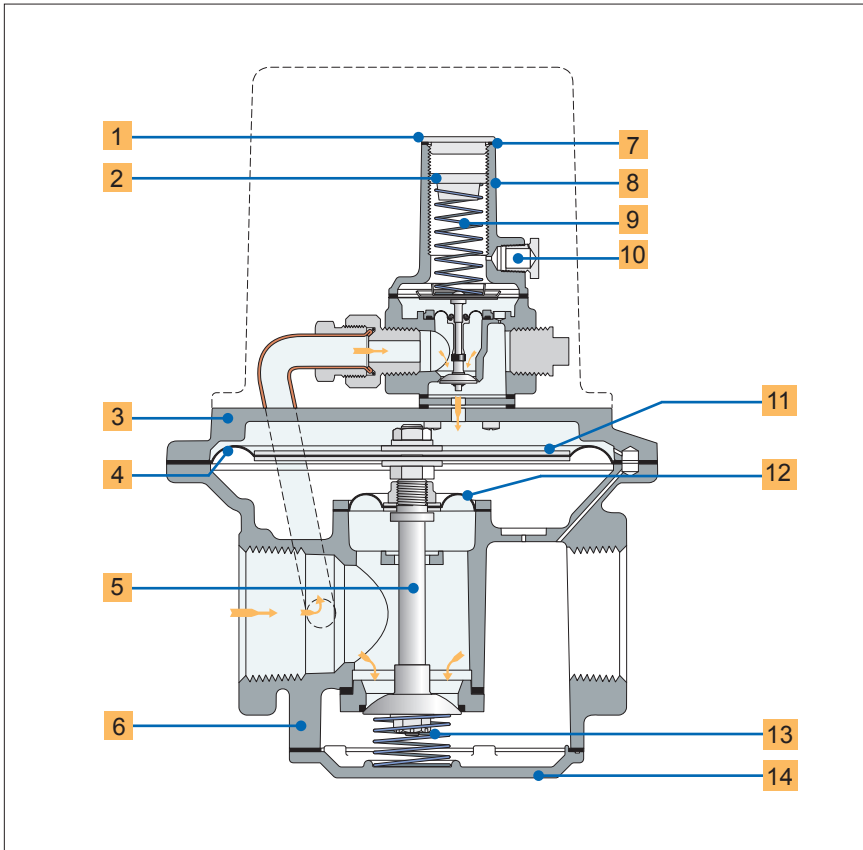

- 1** Seal Cap
- 2** Adjusting Screw
- 3** Top Housing
- 4** Regulating Diaphragm
- 5** Stem & Valve
- 6** Bottom Housing
- 7** Seal Cap Gasket
- 8** Stack
- 9** Spring
- 10** Vent Connection
- 11** Diaphragm Plates
- 12** Balancing Diaphragm
- 13** Counter Spring
- 14** Bottom Plate

NOTE: Diagrams are graphical representations only and may differ from actual product.

SR SERIES

2 Stage Design

An ideal replacement for dual manifold systems, the SR Series combines gas pressure regulating and flame staging in a single unit. Applications include direct-fired heaters with two speed fans, hi-lo control for outdoor heaters, LP natural gas switchover and industrial processing.



SR400

Specifications

Pipe Sizes	3/8" thru 1" threaded connections with NPT or ISO7-1 threads.
Housing Material	SR400, SR500, SR600: aluminum.
Mounting	Mount in an upright position only. NOTE: All Maxitrol gas pressure regulators should be installed and operated in accordance with Maxitrol Safety Warning Instructions (see SELMMRSR_MI_EN.FR.ES).
Certifications	SR400, SR500, SR600: ANSI Z21.18/CSA 6.3 Gas Appliance Pressure Regulators (except suffix -2 models).
Gas Types	Suitable for natural, manufactured, mixed gases, liquefied petroleum gases, and LP gas-air mixtures.
Maximum Inlet Pressure	CSA Certified: 1/2 psi (3.4 kPa) Maxitrol Tested: 1 psi (6.9 kPa)
Flow Rates	up to 1,000 CFH (28.32 m ³ /h)
Emergency Exposure Limits	2.5 psi (17.2 kPa)
Ambient Temperature Ranges	-40 to 175°F (-40 to 79°C)
Minimum Regulation	SR400, SR500: 5 CFH; SR600: 60 CFH

NOTE: SR400-2, SR500-2, SR600-2 models are designed primarily for LP gas applications.

NOTE: All models may be powered by a 24 volt AC transformer. When the coil is energized, the appliance is at low fire. When the coil is de-energized, it is high fire. Continuous regulation is maintained to hold the electrically set outlet pressure constant.



Pressure Drop: inches w.c. (kPa)

Model Number	Pipe Size	Flow Rate - CFH (m ³ /h)							
		100 (2.83)	200 (5.66)	300 (8.50)	400 (11.33)	500 (14.16)	600 (16.99)	750 (21.24)	1000 (28.32)
SR400	3/8" x 3/8"	0.33 (0.08)	1.30 (0.32)	---	---	---	---	---	---
	1/2" x 1/2"	0.27 (0.07)	1.10 (0.27)	---	---	---	---	---	---
SR500	1/2" x 1/2"	0.08 (0.02)	0.30 (0.08)	0.68 (0.17)	1.20 (0.30)	---	---	---	---
	3/4" x 3/4"	0.05 (0.01)	0.21 (0.05)	0.47 (0.12)	0.83 (0.20)	1.30 (0.32)	---	---	---
SR600	3/4" x 3/4"	---	0.09 (0.02)	0.20 (0.05)	0.36 (0.09)	0.56 (0.14)	0.81 (0.20)	1.25 (0.31)	---
	1" x 1"	---	0.07 (0.02)	0.16 (0.04)	0.29 (0.07)	0.45 (0.11)	0.66 (0.16)	1.00 (0.25)	1.75 (0.44)

NOTE: CSA maximum capacities vary with spring range and pipe size. Please contact Maxitrol directly for CSA maximums. See pages 58-59 for Regulator Sizing Requirements and Examples.

Spring Selection: inches w.c. (kPa)

Model	Available Springs					
SR400	Maximum	3 to 5 (0.75 to 1.25) S. Steel	2.5 to 3.5 (0.62 to 0.87) White	4 to 6 (1 to 1.5) S. Steel	3 to 5 (0.75 to 1.25) White	---
	Minimum	0.3 to 1.2 (0.07 to 0.3) Plated	0.3 to 1.2 (0.07 to 0.3) Plated	1 to 2.8 (0.25 to 0.7) Blue	1 to 2.8 (0.25 to 0.7) Blue	2.5 to 4 (0.62 to 1) Black
SR400-2*	Maximum	7.5 to 12 (1.87 to 3) - Blue				
SR500	Maximum	3 to 5 (0.75 to 1.25) S. Steel	1.5 to 3.5 (0.37 to 0.87) White	3.5 to 6 (0.87 to 1.5) S. Steel	2 to 4.5 (0.5 to 1.12) White	---
	Minimum	0.3 to 1.2 (0.07 to 0.3) Plated	0.3 to 1.2 (0.07 to 0.3) Plated	1 to 2.8 (0.25 to 0.07) Plated	1 to 2.8 (0.25 to 0.7) Blue	---
SR500-2*	Maximum	7.5 to 12 (1.87 to 3) - Black				
SR600	Maximum	3 to 5 (0.75 to 1.25) S. Steel	2.5 to 4 (0.62 to 1) Plated	4 to 6 (1 to 1.5) S. Steel	3 to 5.5 (0.75 to 1.37) White	---
	Minimum	0.5 to 1.2 (0.12 to 0.3) Plated	0.3 to 1.2 (0.07 to 0.3) Plated	1 to 2.8 (0.25 to 0.7) Plated	1 to 2.8 (0.25 to 0.7) Blue	---

* For LP application - may be used with any minimum spring.

NOTE: See pages 56-57 for complete Spring Selection Chart.

SR SERIES

2 Stage Design

Dimensions

Model	Pipe Size	Vent Connection	Dimensions			
			A	B	C	D
SR400	3/8", 1/2"	1/8" NPT, 12A06 vent limiting device installed.	4" (102 mm)	2" (51 mm)	2.2" (56 mm)	1" (25 mm)
SR500	1/2", 3/4"	1/8" NPT, 12A06 vent limiting device installed.	5.3" (135 mm)	3.2" (81 mm)	3.4" (86 mm)	1.2" (30 mm)
SR600	3/4", 1"	1/8" NPT, 12A06 vent limiting device installed.	7" (178 mm)	3.9" (99 mm)	4" (102 mm)	1.5" (38 mm)

NOTE: Dimensions are maximums and to be used only as an aid in designing clearance for the valve. Actual production dimensions may vary somewhat from those shown.

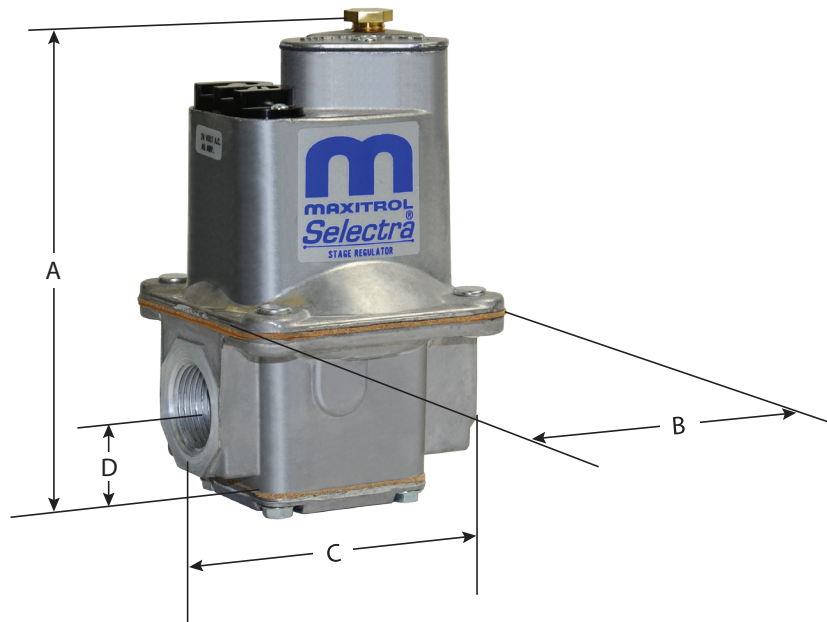

SR400, SR500, SR600

2 Stage Design

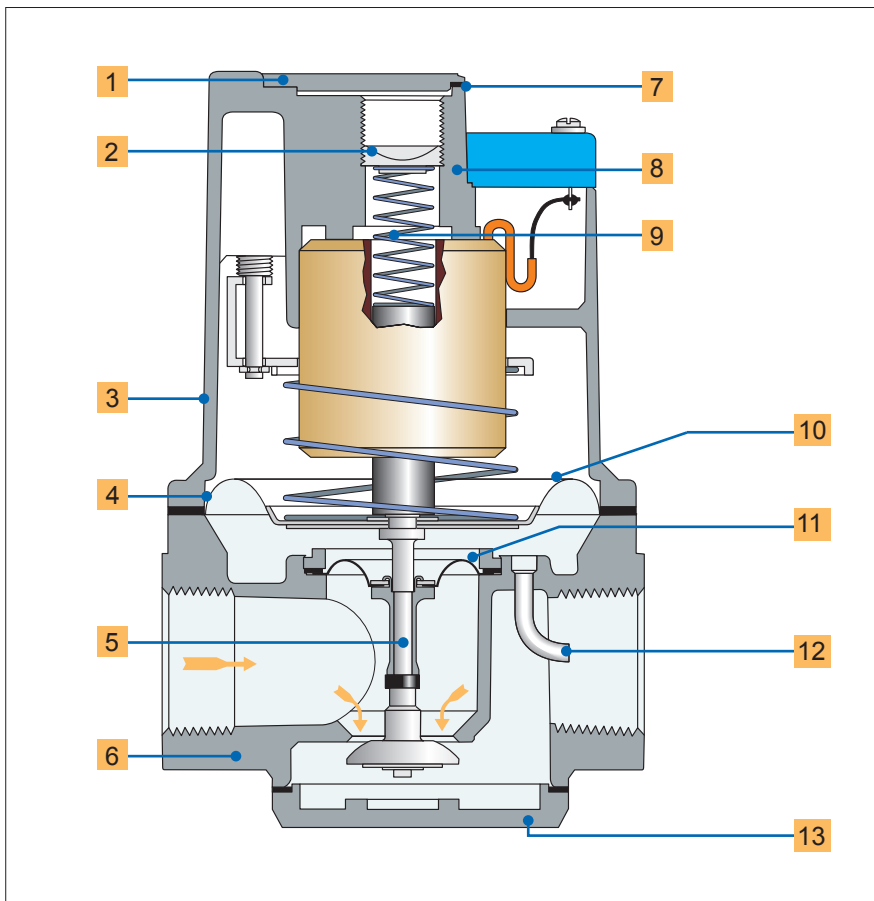

- 1 Seal Cap
- 2 Adjusting Screw
- 3 Top Housing
- 4 Regulating Diaphragm
- 5 Stem & Valve
- 6 Bottom Housing
- 7 Seal Cap Gasket
- 8 Stack
- 9 Spring
- 10 Diaphragm Plates
- 11 Balancing Diaphragm
- 12 Sensing Tube
- 13 Bottom Plate

NOTE: Diagrams are graphical representations only and may differ from actual product.

325-L SERIES

Lever Acting Design for 2 psi Piping Systems

Maxitrol's 325-L Series line pressure regulators are for 2 psi piping systems. 325 Series regulators are for use on residential, commercial, and industrial applications.

The 325 Series features a high leverage linkage assembly to deliver positive dead-end lock-up. The regulators are capable of precise regulating control from full flow down to pilot flow.

NOTE: The 325-9L will be available 2Q2014.



325-3L

Specifications

- Pipe Sizes** 3/8" to 2" threaded connections with NPT or ISO7-1 threads.
- Housing Material** 325-3L, 325-5L, 325-7AL, 325-9L: aluminum.
- Mounting** Suitable for multi-positional mounting. If ball check vent limiting device is installed, mount in an upright position only.
NOTE: All Maxitrol gas pressure regulators should be installed and operated in accordance with Maxitrol Safety Warning Instructions (see GPR_CSA_2PSI_MI_EN.FR).
- Certifications** 325-3L, 325-5L, 325-7AL, 325-9L: ANSI Z21.80/CSA 6.22 Line Pressure Regulators.
- Gas Types** Suitable for natural, manufactured, mixed gases, liquefied petroleum gases, and LP gas-air mixtures.
- Maximum Inlet Pressure** 2 psi (13.8 kPa)
- Minimum Inlet Pressure** 1 psi (6.9 kPa)
- Emergency Exposure Limits** 65 psi (450 kPa) (inlet side only)
- Maximum Individual Load** Largest single appliance served by the regulator: 325-3L: 140,000 Btu/h; 325-5L: 425,000 Btu/h; 325-7AL: 1,250,000 Btu/h; 325-9L: 2,250,000 Btu/h
- Capacity** Total load of multiple appliance combined
325-3L (3/8", 1/2"): 250,000 Btu/h;
325-5L (1/2"): 500,000 Btu/h; 325-5L (3/4", 1"): 600,000 Btu/h;
325-7AL (1 1/4", 1 1/2"): 1,250,000 Btu/h; 325-9L (1 1/2", 2"): 2,250,000 Btu/h
NOTE: Capacities are used to determine the maximum multiple appliance load. The largest single appliance served by the regulator should not exceed the maximum individual load specified above.
- Ambient Temperature Ranges** -40 to 205°F (-40 to 96°C)
- Minimum Regulation** Suitable for pilot flow applications. $\text{\textcircled{P}}$ (Circle P) (0.15 CFH NG), $\text{\textcircled{\nabla}}$ (Delta P) (0.50 CFH NG).
- Imblue Technology™** 325-3L, 325-5L, 325-7AL, 325-9L models may be ordered with Imblue Technology™. Imblue Technology™ increases corrosion resistance and provides extra protection against the elements for regulators used in outdoor applications. Add suffix letter "B" to model number when ordering.



Capacities

Capacities expressed in CFH (m³/h) @ 0.64 sp gr gas

Model	Pipe Size	Outlet Pressure Set Point	Operating Inlet Pressure				
			1/2 psi (3.4 kPa)	3/4 psi (5.2 kPa)	1 psi (6.9 kPa)	1 1/2 psi (10.3 kPa)	2 psi (13.8 kPa)
325-3L	3/8" x 3/8" 1/2" x 1/2"	7.0" w.c. (1.7 kPa)	145 (4.1)	200 (5.7)	250 (7.1)	250 (7.1)	250 (7.1)
		10.0" w.c. (2.5 kPa)	110 (3.1)	180 (5.1)	230 (6.5)	250 (7.1)	250 (7.1)
325-5L	1/2" x 1/2"	7.0" w.c. (1.7 kPa)	360 (10.2)	485 (13.7)	500 (14.2)	500 (14.2)	500 (14.2)
		10.0" w.c. (2.5 kPa)	275 (7.8)	475 (13.5)	500 (14.2)	500 (14.2)	500 (14.2)
325-5L	3/4" x 3/4" 1" x 1"	7.0" w.c. (1.7 kPa)	370 (10.5)	520 (14.7)	600 (17.0)	600 (17.0)	600 (17.0)
		10.0" w.c. (2.5 kPa)	275 (7.8)	450 (12.7)	570 (16.1)	600 (17.0)	600 (17.0)
325-7AL	1 1/4" x 1 1/4" 1 1/2" x 1 1/2"	7.0" w.c. (1.7 kPa)	750 (21.2)	1000 (28.3)	1250 (35.4)	1250 (35.4)	1250 (35.4)
		10.0" w.c. (2.5 kPa)	525 (14.9)	900 (25.5)	1125 (31.9)	1250 (35.4)	1250 (35.4)
325-9L	1 1/2" x 1 1/2" 2" x 2"	7.0" w.c. (1.7 kPa)	1390 (39.4)	2080 (58.9)	2250 (63.7)	2250 (63.7)	2250 (63.7)
		10.0" w.c. (2.5 kPa)	1050 (29.7)	1660 (47.0)	2090 (59.2)	2250 (63.7)	2250 (63.7)

NOTE: See pages 58-59 for Regulator Sizing Requirements and Examples.

Pressure Drop: expressed in CFH (m³/h) @ 0.64 sp gr gas

Model Number	7.0" w.c. (1.7 kPa)	1/2 psi (3.4 kPa)	3/4 psi (5 kPa)
325-3L	145 (4.0)	204 (5.8)	250 (7.0)
325-5L	400 (11.3)	550 (15.6)	670 (19.0)
325-7AL	815 (23.1)	1149 (32.5)	1405 (39.8)
325-9L	1360 (38.5)	2113 (59.8)	2557 (72.4)

Spring Selection

Outlet Pressure Range (all models)

Certified Spring 7" to 11" w.c. (1.7 to 2.7 kPa)

NOTE: See to pages 56-57 for complete Spring Selection Chart.

325-L SERIES

Lever Acting Design for 2 psi Piping Systems

Dimensions

Model	Pipe Size	Vent Connection	Swing Radius	Dimensions		
				A	B	C
325-3L	3/8", 1/2"	1/8" NPT	3" (76 mm)	3.5" (89 mm)	4.2" (108 mm)	3.9" (98 mm)
325-5L	1/2", 3/4", 1"	3/8" NPT	4.9" (124 mm)	5.3" (133 mm)	5.9" (149 mm)	5.4" (138 mm)
325-7AL	1 1/4", 1 1/2"	1/2" NPT	6.1" (156 mm)	7.3" (184 mm)	8" (203 mm)	7" (178 mm)
325-9L	1 1/2", 2"	1/2" NPT	7.8" (198 mm)	9.4" (239 mm)	10.8" (274 mm)	9.1" (231 mm)

NOTE: Dimensions are maximums and to be used only as an aid in designing clearance for the valve.
Actual production dimensions may vary somewhat from those shown.

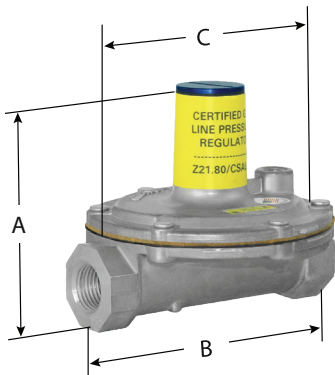

325-3L

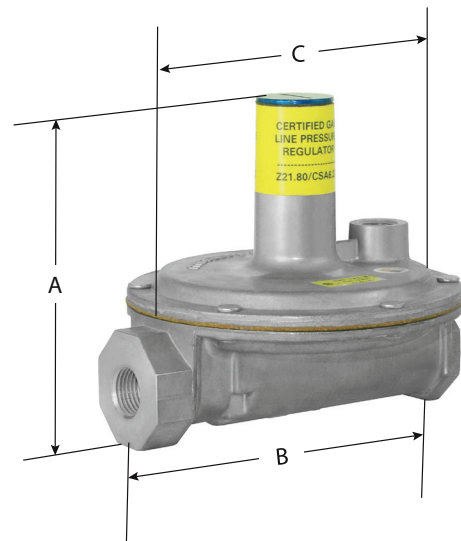

325-5L

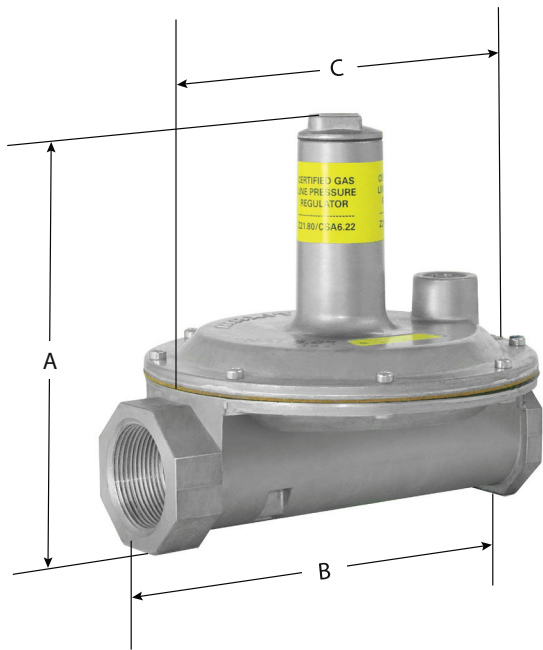

325-7AL

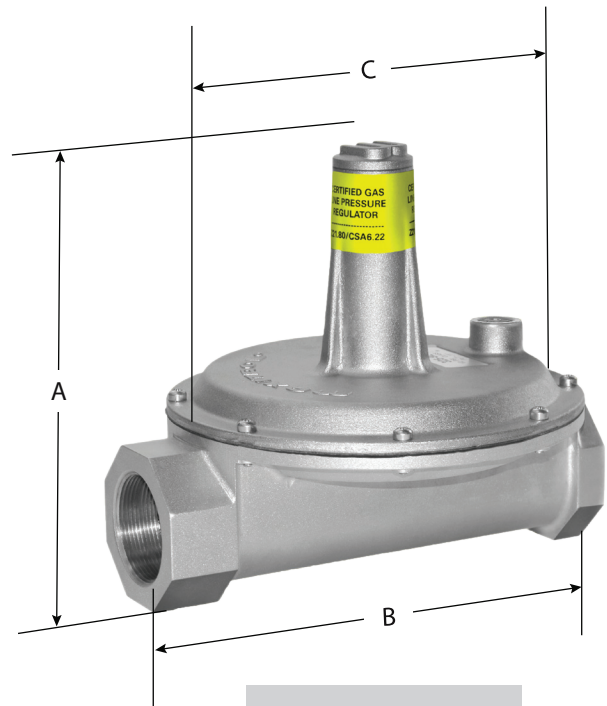

325-9L

Lever Acting Design

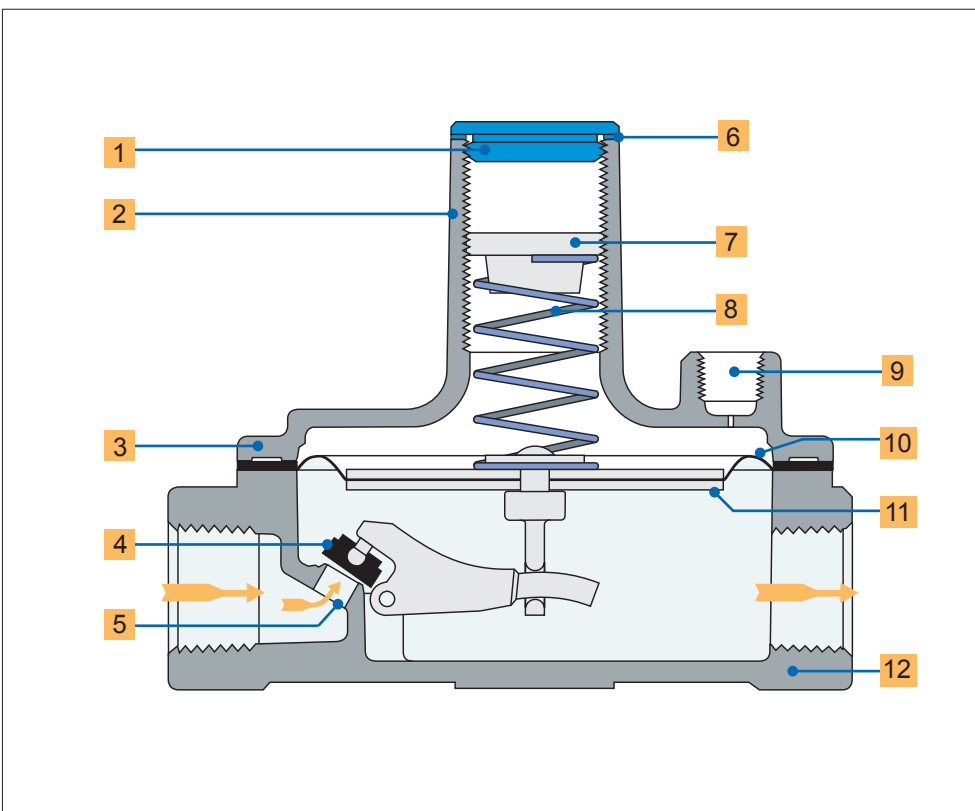

- 1 Seal Cap
- 2 Stack
- 3 Top Housing
- 4 Rubber Valve
- 5 Valve Seat
- 6 Seal Cap Gasket
- 7 Adjusting Screw
- 8 Spring
- 9 Vent Connection
- 10 Diaphragm
- 11 Diaphragm Plates
- 12 Bottom Housing

NOTE: Diagrams are graphical representations only and may differ from actual product.

325-L SERIES

Lever Acting Design with OPDs
for 5 psi Piping Systems

Maxitrol's 325-L Series line pressure regulators with OPDs are for use on piping systems up to 5 psi. The regulator reduces pounds pressure to a level within the appliance or equipment's operating supply range. The line regulator is located upstream of equipment already fitted with an appliance regulator.



325-3L47

NOTE: The 325-9L210E will be available 2Q2014

Specifications

- Pipe Sizes** 3/8" thru 2" threaded connections with NPT or ISO7-1 threads.
- Housing Material** All models: aluminum.
- Mounting** All models with the exception of 325-7AL210D and 325-9L210E are suitable for multi-positional mounting. 325-7AL210D and 325-9L210E are to be mounted in a horizontal position only. If ball check vent limiting device is installed, mount in an upright position only. **NOTE:** Line pressure regulators with separate overpressure protection devices are factory preassembled and supplied to the field as a unit. All Maxitrol gas pressure regulators should be installed and operated in accordance with Maxitrol Safety Warning Instructions (see LPROPD_MI_EN.FR).
- Certifications** All models: ANSI Z21.80/CSA 6.22 Line Pressure Regulators
- Gas Types** Suitable for natural, manufactured, mixed gases, liquefied petroleum gases, and LP gas-air mixtures.
- Maximum Inlet Pressure** 5 psi (34.5 kPa)
With 12A09, 12A39, or 12A49 Vent Limiter Installed
Natural: 5 psi (34.5 kPa); LP: 2 psi (13.8 kPa)
- Minimum Inlet Pressure** 1 psi (7 kPa)
- Emergency Exposure Limits** 65 psi (450 kPa) (inlet side only)
- Maximum Individual Load/
Capacity** 325-3L47 (3/8", 1/2") (w/OPD 47 attached)..... 125,000 Btu/h
325-3L48 (1/2") (w/OPD 48 attached)..... 200,000 Btu/h
325-5L48 (1/2") (w/OPD 48 attached).....235,000 Btu/h
325-5L48 (3/4") (w/OPD 48 attached).....320,000 Btu/h
325-5L600 (3/4") (w/OPD 600 attached).....425,000 Btu/h
325-5L600 (1") (w/OPD 600 attached).....465,000 Btu/h
325-7AL210D (1 1/4", 1 1/2") (w/OPD 210D attached)1,250,000 Btu/h
325-9L210E (1 1/2", 2") (w/OPD210E attached).....2,250,000 Btu/h
- Ambient Temperature Ranges**..... -40 to 205°F (-40 to 96°C)
- Minimum Regulation**..... Suitable for pilot flow applications. **Ⓟ** (Circle P) (0.15 CFH NG), **△** (Delta P) (0.50 CFH NG).



Capacities

Capacities expressed in CFH (m³/h) @ 0.64 sp gr gas

Model Number	Pipe Size	Outlet Pressure Set Point	Operating Inlet Pressure			
			1/2 psi (3.4 kPa)	3/4 psi (5.2 kPa)	1 psi (6.9 kPa)	5 psi (34.5 kPa)
325-3L47	3/8" x 3/8"	7" w.c.	125 (3.5)	125 (3.5)	125 (3.5)	125 (3.5)
		10" w.c.	100 (2.8)	125 (3.5)	125 (3.5)	125 (3.5)
325-3L47	1/2" x 1/2"	7" w.c.	125 (3.5)	125 (3.5)	125 (3.5)	125 (3.5)
		10" w.c.	105 (2.9)	125 (3.5)	125 (3.5)	125 (3.5)
325-3L48	1/2" x 1/2"	7" w.c.	160 (4.5)	200 (5.6)	200 (5.6)	200 (5.6)
		10" w.c.	120 (3.4)	200 (5.6)	200 (5.6)	200 (5.6)
325-5L48	1/2" x 1/2"	7" w.c.	235 (6.6)	235 (6.6)	235 (6.6)	235 (6.6)
		10" w.c.	235 (6.6)	235 (6.6)	235 (6.6)	235 (6.6)
325-5L48	3/4" x 3/4"	7" w.c.	320 (9.0)	320 (9.0)	320 (9.0)	320 (9.0)
		10" w.c.	245 (6.9)	320 (9.0)	320 (9.0)	320 (9.0)
325-5L600	3/4" x 3/4"	7" w.c.	345 (9.6)	425 (11.9)	425 (11.9)	425 (11.9)
		10" w.c.	260 (7.3)	425 (11.9)	425 (11.9)	425 (11.9)
325-5L600	1" x 1"	7" w.c.	375 (10.5)	465 (13.0)	465 (13.0)	465 (13.0)
		10" w.c.	285 (8.0)	465 (13.0)	465 (13.0)	465 (13.0)
325-7AL210D	1 1/4" x 1 1/4"	7" w.c.	815 (22.8)	1120 (31.4)	1250 (35.4)	1250 (35.4)
		10" w.c.	580 (16.2)	900 (25.2)	1100 (30.8)	1250 (35.4)
325-7AL210D	1 1/2" x 1 1/2"	7" w.c.	815 (22.8)	1120 (31.4)	1250 (35.4)	1250 (35.4)
		10" w.c.	580 (16.2)	900 (25.2)	1100 (30.8)	1250 (35.4)
325-9L210E	1 1/2" x 1 1/2"	7" w.c.	1380 (38.6)	2000 (56.0)	2250 (63.0)	2250 (63.0)
		10" w.c.	890 (24.9)	1750 (49.0)	2100 (58.8)	2250 (63.0)
325-9L210E	2" x 2"	7" w.c.	1380 (38.6)	2000 (56.0)	2250 (63.0)	2250 (63.0)
		10" w.c.	890 (24.9)	1750 (49.0)	2100 (58.8)	2250 (63.0)

NOTE: See pages 58-59 for Regulator Sizing Requirements and Examples.

Imblue Technology™: All models may be ordered with Imblue Technology™. Imblue Technology™ increases corrosion resistance and provides extra protection against the elements for regulators used in outdoor applications. Add suffix letter "B" to model number when ordering.

325-L SERIES

Lever Acting Design with OPDs
for 5 psi Piping Systems

Pressure Drop

Pressure Drop expressed in CFH (m³/h) @ 0.64 sp gr gas

Model Number	Pipe Size	Pressure Drop		
		7" w.c. (1.7 kPa)	1/2 psi (3.4 kPa)	3/4 psi (5.2 kPa)
325-3L47	3/8" x 3/8"	130 (3.6)	185 (5.2)	225 (6.3)
325-3L47	1/2" x 1/2"	135 (3.8)	195 (5.4)	235 (6.6)
325-3L48	1/2" x 1/2"	160 (4.5)	225 (6.3)	275 (7.7)
325-5L48	1/2" x 1/2"	315 (8.8)	450 (12.6)	545 (15.4)
325-5L48	3/4" x 3/4"	325 (9.1)	465 (13.0)	565 (16.0)
325-5L600	3/4" x 3/4"	345 (9.6)	490 (13.7)	595 (16.8)
325-5L600	1" x 1"	375 (10.5)	535 (15.0)	650 (18.4)
325-7AL210D	1 1/4" x 1 1/4"	800 (22.7)	1095 (31.0)	1385 (39.2)
325-7AL210D	1 1/2" x 1 1/2"	800 (22.7)	1095 (31.0)	1385 (39.2)
325-9L210E	1 1/2" x 1 1/2"	1360 (38.5)	2113 (59.8)	2557 (72.4)
325-9L210E	2" x 2"	1360 (38.5)	2113 (59.8)	2557 (72.4)

NOTE: See pages 58-59 for Regulator Sizing Requirements and Examples.

Spring Range Selection

Outlet Pressure Range (all models)

Certified Spring 7" to 11" w.c. (1.7 to 2.7 kPa)

NOTE: Please refer to pages 56-57 for complete Spring Selection Chart.

Lever Acting Design

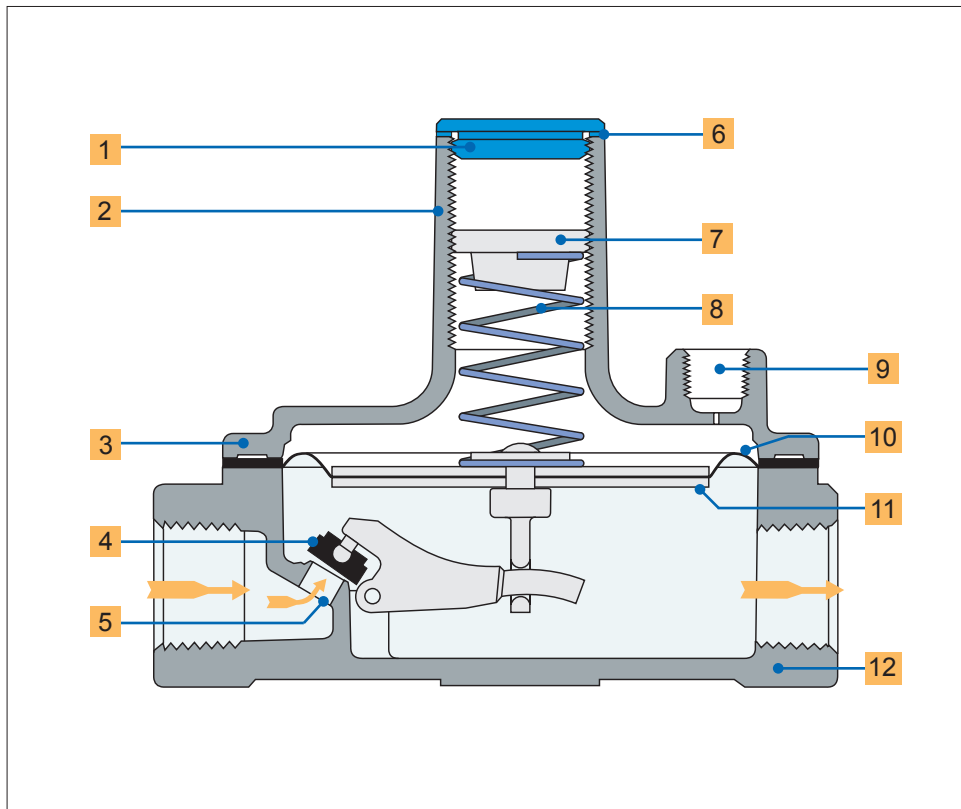

- 1 Seal Cap
- 2 Stack
- 3 Top Housing
- 4 Rubber Valve
- 5 Valve Seat
- 6 Seal Cap Gasket
- 7 Adjusting Screw
- 8 Spring
- 9 Vent Connection
- 10 Diaphragm
- 11 Diaphragm Plates
- 12 Bottom Housing

NOTE: Diagrams are graphical representations only and may differ from actual product.

325-L SERIES

Lever Acting Design with OPDs
for 5 psi Piping Systems

Dimensions

Model	Pipe Size	Vent Connection	Swing Radius	Dimensions		
				A	B	C
325-3L47	3/8", 1/2"	325-3L: 1/8" OPD47: Integral	3" (76 mm)	3.5" (89 mm)	8" (203 mm)	3.9" (99 mm)
325-3L48	1/2"	325-3L: 1/8" OPD48: 1/8"	3" (76 mm)	3.5" (89 mm)	8.5" (216 mm)	3.9" (99 mm)
325-5L48	1/2", 3/4"	325-5L: 3/8" OPD48: 1/8"	4.4" (112 mm)	5.3" (135 mm)	10" (254 mm)	5.4" (137 mm)
325-5L600	3/4", 1"	325-5L: 3/8" OPD600: 1/8"	4.4" (112 mm)	5.5" (140 mm)	11" (279 mm)	5.4" (137 mm)
325-7AL210D	1 1/4", 1 1/2"	325-7AL: 1/2" OPD210D: 3/8"	6.75" (171 mm)	7" (178 mm)	15.4" (391 mm)	9" (229 mm)
325-9L210E	1 1/2", 2"	325-9L: 1/2" OPD210E: 1/2"	8.3" (211 mm)	9.4" (239 mm)	20.6" (523 mm)	9.1" (231 mm)

NOTE: Dimensions are maximums and to be used only as an aid in designing clearance for the valve.
Actual production dimensions may vary somewhat from those shown.

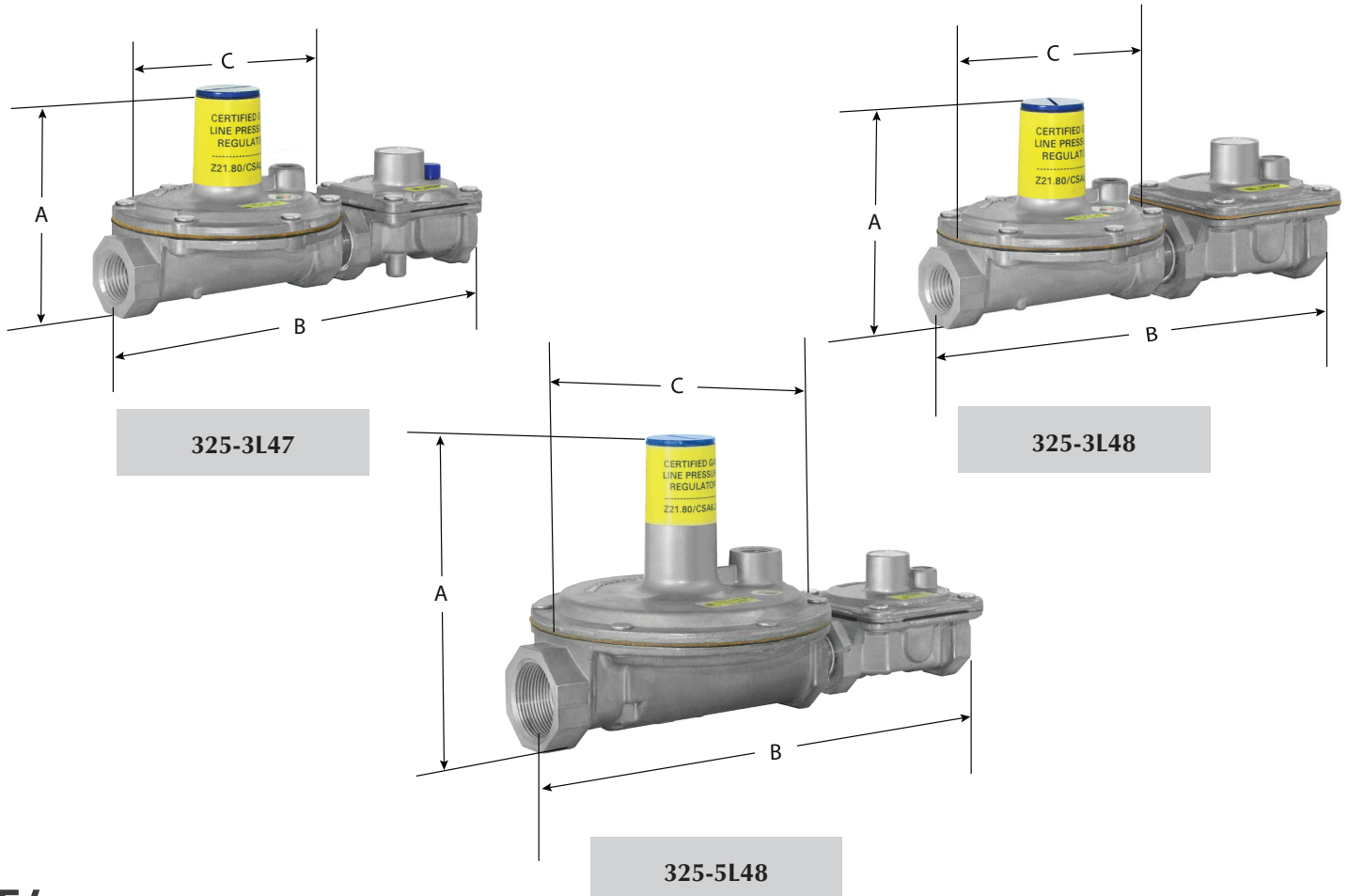

LINE REGULATORS

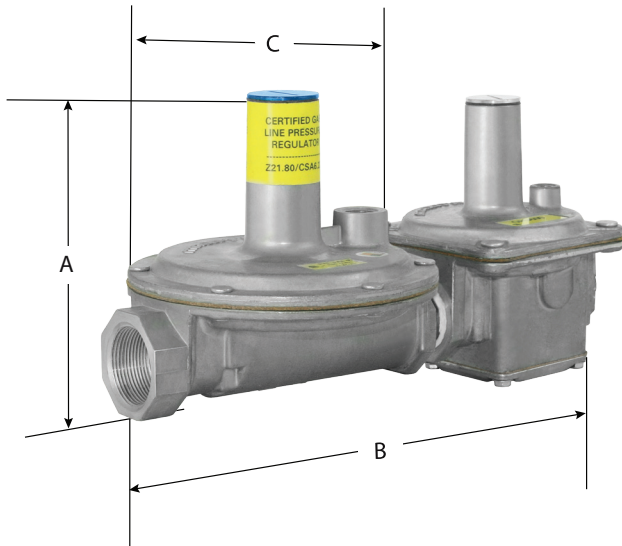

325-5L600

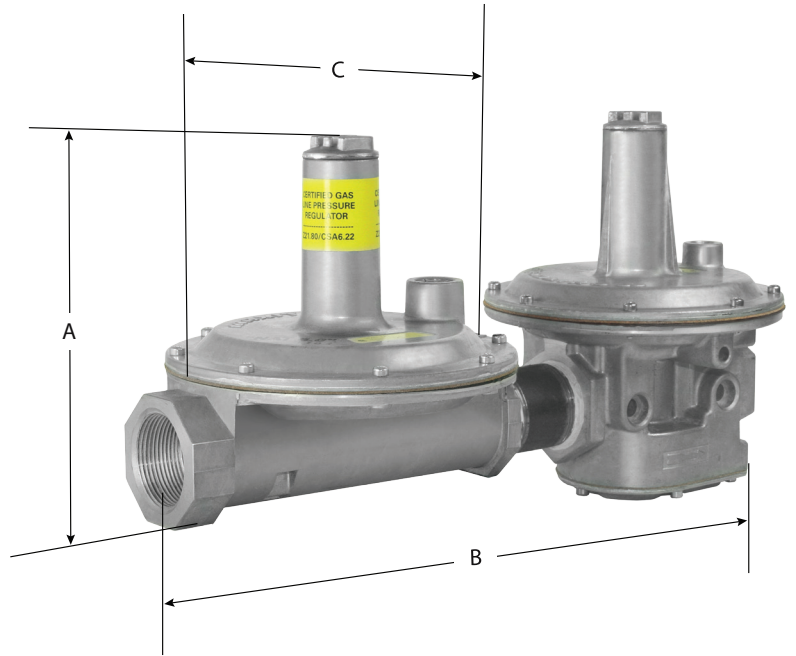

325-7AL210D

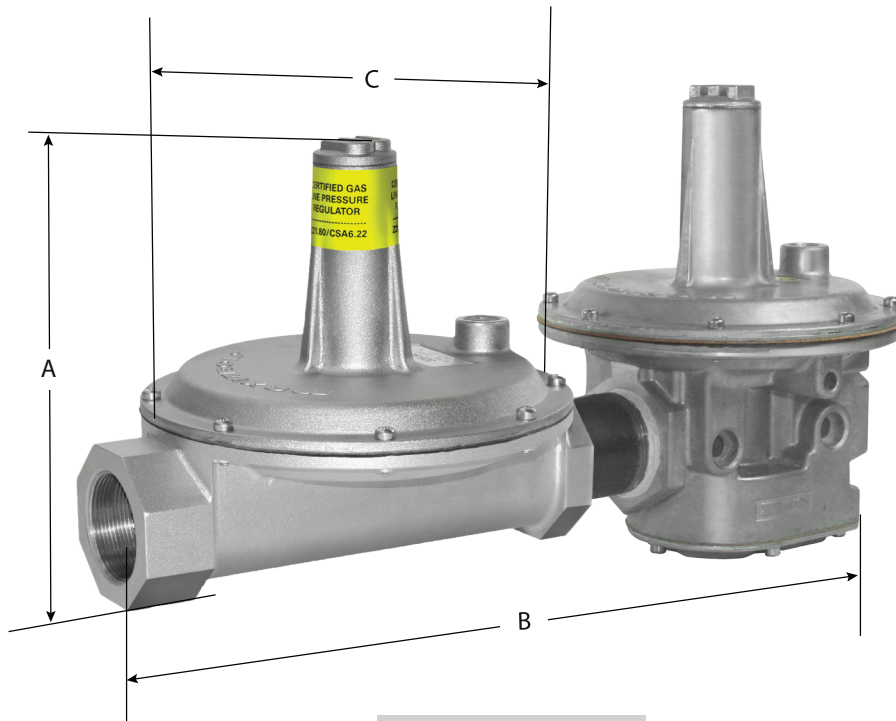

325-9L210E

SPRING SELECTION CHART

Model #	Part Number	Color Code	Outlet Pressure (In. w.c.)	Approx Inner Diameter	Approx Length
Adjustable Models:					
RV12L	R1210T-13 R1210T-35* R1210T-48 R1210T-610 R1210T-812	Brown Plated Orange Red Blue	1.0 to 3.5 2.8 to 5.2 4.0 to 8.0 6.0 to 10 8.0 to 12	3/8"	9/16" 3/4" 3/4" 7/8" 1"
RV20L	R2010-13 R2010-35* R2010-48 R2010-610 R2010-812 R2010-912	Brown Plated Orange Red Blue Plated	1.0 to 3.5 2.8 to 5.2 4.0 to 8.0 6.0 to 10 8.0 to 12 9.0 to 12	7/16"	13/16" 1 1/16" 15/16" 1" 1 1/8" 1 9/16"
RV20LT	R2010T-35* R2010T-48 R2010T-210 R2010T-812	Plated Orange Red Blue	2.8 to 5.2 4.0 to 8.0 6.0 to 10 8.0 to 12	7/16"	1 1/16" 15/16" 1" 1 1/8"
RV47AD RV47AL	R4710-4 R4710-5 R4710-6 R4710-10	Black Green Red Blue	3.8 to 4.3 4.7 to 5.3 5.6 to 6.4 9.7 to 11.3	9/16"	1 3/4" 1 13/16" 1 13/16" 1 11/16"
RV47D RV47L	R4710-13 R4710-35* R4710-48 R4710-412 R4710-610 R4710-812	Brown Plated Orange Violet Red Blue	1.0 to 3.5 2.8 to 5.2 4.0 to 8.0 4.0 to 12 6.0 to 10 8.0 to 12	9/16"	7/8" 1 1/4" 1 5/16" 1 1/16" 1 7/16" 1 1/2"
RV48	R4810-13 R4810-36* R4810-48 R4810-512 R4810-610	Brown Plated Orange Blue Red	1.0 to 3.5 3.0 to 6.0 4.0 to 8.0 5.0 to 12 6.0 to 10	9/16"	15/16" 1 3/16" 1 1/8" 1 3/16" 1 1/2"
RV48T	R4810T-36* R4810T-48 R4810T-512 R4810T-610	S Steel Orange Blue Red	3.0 to 6.0 4.0 to 8.0 5.0 to 12 6.0 to 10	9/16"	1 3/16" 1 1/8" 1 3/16" 1 1/2"
R400 R400S	R400B10-13 R400B10-25 R400B10-36* R400B10-38 R400B10-412 R400B10-512 R400B10-1022	Brown Plated Plated Pink Violet Blue Red	1.0 to 3.5 2.0 to 5.0 3.0 to 6.0 3.0 to 8.0 4.0 to 12 5.0 to 12 10 to 22	3/8"	1 1/4" 1 9/16" 2" 1 9/16" 1 1/2" 1 7/8" 1 3/4"
RV52 R500 R500S	R5210-13 R5210-25 R5210-36* R5210-38 R5210-48 R5210-412 R5210-512	Brown Plated Plated Pink Orange Violet Blue	1.0 to 3.5 2.0 to 5.0 3.0 to 6.0 3.0 to 8.0 4.0 to 8.0 4.0 to 12 5.0 to 12	9/16"	2" 2 9/16" 2 7/8" 2 9/16" 3 1/8" 2 1/2" 2 15/16"
R500 R500S	R5210-1022	Red	10 to 22	9/16"	2 13/16"
RV53 R600 R600S	R5310-13 R5310-25 R5310-36* R5310-38 R5310-48 R5310-412 R5310-512	Brown Plated Plated Pink Orange Violet Blue	1.0 to 3.5 2.0 to 5.0 3.0 to 6.0 3.0 to 8.0 4.0 to 8.0 4.0 to 12 5.0 to 12	5/8"	2 5/8" 2 15/16" 3 3/8" 3 1/16" 3 5/8" 3 1/6" 3 7/16"

* Standard Spring

Model #	Part Number	Color Code	Outlet Pressure (In. w.c.)	Approx Inner Diameter	Approx Length
Adjustable Models:					
R600 R600S	R5310-1022 R5310-1530	Red Yellow	10 to 22 15 to 30	5/8"	3 1/4" 3 1/2"
RV61	R6110-13 R6110-25 R6110-36* R6110-38 R6110-48 R6110-512 R6110-1022	Brown Plated Plated Pink Orange Blue Red	1.0 to 3.5 2.0 to 5.0 3.0 to 6.0 3.0 to 8.0 4.0 to 8.0 5.0 to 12 10 to 22	3/4"	2 5/8" 3 1/4" 3 1/2" 3 1/8" 3 9/16" 3 9/16" 3 1/2"
RV81 210D	R8110-13 R8110-25 R8110-36* R8110-38 R8110-48 R8110-412 R8110-512 R8110-515 R8110-1022	Brown Plated Plated Pink Orange Violet Blue Green Red	1.0 to 3.5 2.0 to 5.0 3.0 to 6.0 3.0 to 8.0 4.0 to 8.0 4.0 to 12 5.0 to 12 5.0 to 15 10 to 22	7/8"	3 1/8" 3 13/16" 4 5/16" 3 7/8" 4 1/2" 3 3/4" 4 1/16" 3 3/4" 4 5/16"
210D	R8110-1530 R8110-2042	Yellow Black	15 to 30 20 to 42	7/8"	4 1/2" 4 5/16"
RV91 210E	R9110-13 R9110-25 R9110-36* R9110-38 R9110-48 R9110-412 R9110-512 R9110-515 R9110-1022	Brown Plated Plated Pink Orange Violet Blue Green Red	1.0 to 3.5 2.0 to 5.0 3.0 to 6.0 3.0 to 8.0 4.0 to 8.0 4.0 to 12 5.0 to 12 5.0 to 15 10 to 22	1 1/8"	4" 4 15/16" 5 3/4" 5 1/16" 5 15/16" 5 1/16" 5 1/2" 5 1/8" 5 5/8"
210E	R9110-1530 R9110-2042*	Yellow Black	15 to 30 20 to 42	1 7/8"	5 7/8" 5 3/4"
RV111 210G	R11110-13 R11110-25 R11110-36* R11110-38 R11110-48 R11110-412 R11110-512 R11110-515 R11110-1022	Brown Plated Plated Pink Orange Violet Blue Green Red	1.0 to 3.5 2.0 to 5.0 3.0 to 6.0 3.0 to 8.0 4.0 to 8.0 4.0 to 12 5.0 to 12 5.0 to 15 10 to 22	1 1/2"	6 1/8" 7 1/6" 8 5/16" 7 3/8" 8 3/8" 7 3/8" 8 1/8" 7 1/16" 8 1/8"
210G	R11110-1530 R11110-2042	Yellow Black	15 to 30 20 to 42	1 1/2"	8 7/16" 8 1/4"
RV131 210J	R13110-25 R13110-36* R13110-38 R13110-412 R13110-512 R13110-1022 R13110-1530 R13110-2042	Plated Plated Pink Violet Blue Red Yellow Black	2.0 to 5.0 3.0 to 6.0 3.0 to 8.0 4.0 to 12 5.0 to 12 10 to 22 15 to 30 20 to 42	2 1/8"	9 1/6" 11 3/4" 10 1/8" 9 7/8" 11 5/8" 11 1/2" 11 11/16" 11 1/4"
220D, E,G,& J	R325C10-1022 R325C10-1530	Tagged Tagged	1 psi-3 psi 2 psi-5 psi	5/8"	2 1/8" 2 5/16"

SPRING SELECTION CHART

Model #	Part Number	Color Code	Outlet Pressure (In. w.c.)	Approx Inner Diameter	Approx Length
Adjustable Models:					
325-3	R325C10-26	Plated	2.0 to 6.0	5/8"	1 3/4"
	R325C10-59	Plated	5.0 to 9.0 #		2 5/16"
	R325C10-412*	Violet	4.0 to 12		1 3/4"
	R325C10-711	White	7.0 to 11		2 5/8"
	R325C10-1022	Red	10 to 22		2 1/8"
	R325C10-1530	Yellow	15 to 30		2 5/16"
R325C10-P12	Tagged	1 psi-2 psi	2 5/16"		
325-5	R325E10-26A	Plated	2.0 to 6.0	3/4"	2 7/8"
	R325E10-59A	Plated	5.0 to 9.0 #		4 3/16"
	R325E10-412A*	Violet	4.0 to 12		3 1/8"
	R325E10-711A	White	7.0 to 11		4"
	R325E10-1022A	Red	10 to 22		3 9/16"
	R325E10-1530A	Yellow	15 to 30		3 5/8"
R325E10-P12A	Tagged	1 psi-2 psi	3 3/4"		
325-7A	R8110-25	Plated	2.0 to 5.0	7/8"	3 13/16"
	R8110-412*	Violet	4.0 to 12		3 3/4"
	R8110-1022	Red	10 to 22		4 5/16"
	R8110-1530	Yellow	15 to 30		4 1/2"
	R8110-2042	Black	20 to 42		4 5/16"
	R325G10-711	White	7.0 to 11		4 5/8"
325-9	R9110-25	Plated	2.0 to 5.0	1 1/8"	4 15/16"
	R9110-412*	Violet	4.0 to 12		5 1/16"
	R9110-1022	Red	10 to 22		5 5/8"
	R9110-1530	Yellow	15 to 30		5 7/8"
	R9110-2042	Black	20 to 42		5 3/4"
	R325J10-711	White	7.0 to 11		6 1/2"

Model #	Part Number	How Used	Color Code	Approx Inner Diameter	Approx Length
Zero Governor Models:					
R400Z	R400B10-13	Regulate Counter	Brown Plated	3/8"	1 1/4"
	R400B10Z			1/2"	3/4"
R500Z	R5210-13	Regulate Counter	Brown Plated	9/16"	2"
R600Z	R5310-13	Regulate Counter	Brown Plated	5/8"	2 5/8"
210DZ	R8110-13	Regulate Counter	Brown Plated	7/8"	3 1/8"
	R210D10Z			1"	3 3/8"
210EZ	R9110-13	Regulate Counter	Brown Plated	1 1/8"	4"
	R210E10Z			1 7/16"	4 3/4"
210GZ	R11110-13	Regulate Counter	Brown Plated	1 1/2"	6 1/8"
	R210G10Z			2 1/16"	6 3/4"
210JZ	R13110-25	Regulate Counter	Brown Plated	2 1/8"	9 1/16"
	R210J10Z			2 7/8"	9 1/4"

Model #	Part Number	Min / Max	Color Code	Outlet Pressure (In. w.c.)	Approx Inner Diameter	Approx Length
Adjustable Models:						
SR400	SR400B10H	Max	S Steel	3.0 to 5.0	5/16"	1 5/16"
	MR410B10L	Min	Plated	0.3 to 1.2		7/8"
	SR400B10H-1	Max	White	2.5 to 3.5		1"
	MR410B10L	Min	Plated	0.3 to 1.2		7/8"
	SR400B10H	Max	S Steel	4.0 to 6.0		1 1/16"
MR410B10L-1	Min	Blue	1.0 to 2.8	1 1/16"		
SR400B10H-1	MR410B10L-1	Max	White	3.0 to 5.0	1"	1 1/16"
	MR410B10L-1	Min	Blue	1.0 to 2.8		1 1/16"
SR400B10L-4	Min	Black	2.5 to 4.0	1 3/16"		
SR400-2**	SR400B10H-2	Max	Blue	7.5 to 12.0	5/16"	1 1/2"
SR500	SR500B10H	Max	S Steel	3.0 to 5.0	7/16"	1 9/16"
	MR510B10L	Min	Plated	0.3 to 1.2		1 1/16"
	SR500B10H-1	Max	White	1.5 to 3.5		1 1/16"
	MR510B10L	Min	Plated	0.3 to 1.2		1 1/16"
SR500B10H	MR510B10L-1	Max	S Steel	3.5 to 6.0	1 5/8"	1 9/16"
	MR510B10L-1	Min	Plated	1.0 to 2.8	1 1/4"	
SR500B10H-1	MR510B10L-1	Max	White	2.0 to 4.5	1 1/16"	1 1/16"
	MR510B10L-1	Min	Blue	1.0 to 2.8		1 1/4"
SR500-2**	SR500B10L-2*	Max	Black	7.5 to 12.0	7/16"	2 1/4"
SR600	SR600B10H	Max	S Steel	3.0 to 5.0	5/8"	2"
	MR610B10L	Min	Plated	0.3 to 1.2		1 9/16"
	SR600B10H-1	Max	White	2.5 to 4.0		1 1/2"
	MR610B10L	Min	Plated	0.3 to 1.2		1 9/16"
SR600B10H	MR610B10L-1	Max	S Steel	4.0 to 6.0	2 1/8"	2"
	MR610B10L-1	Min	Plated	1.0 to 2.8	1 13/16"	
SR600B10H-1	MR610B10L-1	Max	White	3.0 to 5.5	1 1/2"	1 1/2"
	MR610B10L-1	Min	Blue	1.0 to 2.8		1 13/16"

* Standard Spring

**L.P. - May be used with any minimum spring.

- or 6.0 to 10.0 for 5 psi

NOTE: Spring free length is given as an aid to identification only. Variations of $\pm 1/2"$, although unlikely, can occur. This variation will not effect the spring range.

SIZING A REGULATOR

See www.maxitrol.com for our Regulator Sizing Program. Please contact Maxitrol directly for more information on sizing a regulator.

System Requirements

When sizing a regulator the following must be known:

- Gas Type
- Available Inlet Pressure
- Desired Outlet Pressure
- Zero Governor Application (indicated by model number ending in "Z")
- Will the regulator control main burner and pilot load OR main burner only?
- Required minimum and maximum flow rate in cfh or m³/h or Btu/h
- Pipe Size

In most cases, the manifold pipe size has already been selected on the basis of good engineering practice, and the regulator pipe size should conform to this size.

The capacity of any regulator is not an absolute value but will vary with the application depending on the prevailing differential pressure.

⚠ WARNING

Service and installation must be performed by a trained/experienced service technician.

All products used with combustible gas must be installed and used strictly in accordance with the instructions of the Original Equipment Manufacturer (OEM) and with all applicable government codes and regulations, e.g. plumbing, mechanical, and electrical codes and practices. These instructions do NOT supersede OEM's installation or operating instructions.

All Maxitrol products should be installed and operated in accordance with Maxitrol Safety Warning Instructions.

HOW TO CALCULATE PRESSURE DROP AT VARIOUS FLOW RATES FROM CAPACITY CHART

LP Applications - When using natural gas pressure drop chart to determine LP pressure drop in terms of Btu/h, multiply LP Btu/h by 0.621; in terms of CFH multiply LP CFH by 1.55.

$$\text{Formula: } P_2 = P_1 \times (Q_2/Q_1)^2$$

P₂ = Pressure drop at desired flow rate

P₁ = Known pressure drop

Q₂ = Desired flow rate

Q₁ = Known flow rate

A. Check Capacity Chart, insuring regulator has ample range of regulation and individual load capacities (for use with pilot) for the application.

B. Know the minimum encountered inlet pressure. MINIMUM INLET PRESSURE MINUS "P₂" MUST BE GREATER THAN DESIRED OUTLET PRESSURE. Solve for "P₂" using the formula above. (See examples on page 59.)

Sizing Examples

RUBBER SEAT POPPETS

For main burner and pilot load applications.

Example: To select an RV type regulator:

- Known: Single 150,000 Btu/h main burner; pipe size 1/2"; inlet pressure 7" w.c.; outlet pressure 4" w.c.
- Solution: The RV48 (1/2") has a maximum capacity of 230,000 Btu/h and a maximum individual load of 160,000 Btu/h. The pressure drop at a flow rate of 150,000 Btu/h is 0.4" w.c., well below the available differential of 3" w.c. The RV48 (without "L" fixed orifice) is the correct regulator to use for the application.

STRAIGHT-THRU-FLOW (S-T-F)

For main burner only applications not requiring a lock up type regulator. When sizing the S-T-F Series, it is recommended that pressure drop not exceed 1/2 of available differential pressure.

Example: To select an RV type regulator:

- Known: Flow rate 2,000,000 Btu/h; pipe size 1 1/4"; inlet pressure 9" w.c.; outlet pressure 5" w.c.
- Solution: The RV81 (1 1/4") has a maximum capacity of 2,500,000 Btu/h. The pressure drop at a flow of 2,000,000 Btu/h is 0.66" w.c. The RV81 (1 1/4") is the correct regulator to use with this application. The pressure drop of the RV61 (1 1/4") at a flow rate of 2,000,000 Btu/h is 2.64" w.c. This is within the available differential but exceeds the recommended 50% maximum.

LEVER ACTING

For main burner and pilot load application requiring positive dead-end lock up (see Definitions page 63).

Example: To select a 325 Series regulator:

- Known: Single 145,000 Btu/h burner; pipe size 1/2"; inlet pressure 2 psi; outlet pressure 7" w.c.
- Solution: The 325-3's pressure drop at a flow rate of 145,000 Btu/h is 7" w.c., well below the available differential of 1 3/4 psi. The 325-3 (1/2") is the correct regulator to use with this application.

BALANCED VALVE

For main burner and pilot load application requiring a lock up type regulator or zero governor usage (see Definitions page 63).

Example: To select a 210 or R/RS Series regulator:

- Known: Desired flow rate 6,000,000 Btu/h; pipe size 1 1/2"; inlet pressure 1 psi; outlet pressure 9" w.c.
- Solution: The 210E (1 1/2") has a maximum capacity of 10,000,000 Btu/h. The 210D (1 1/2") has a capacity of 6,000,000 Btu/h. Therefore, the 210E (1 1/2") will give you the desired outlet pressure of 9" w.c. and is the correct regulator to use for the application.

ACCESSORIES

Vent Tube Connector

Threaded sleeve - two piece assembly where the nut is tightened inside male connector.

- **11A03:** connects 1/8" female pipe thread to 1/8" O.D. tubing.
- **11A04:** connects 1/8" female pipe thread to 1/4" O.D. tubing.

Threaded sleeve nut - for RV20V.

- **11A08:** 5/16-24 threaded sleeve nut for 1/8" O.D. tubing.

Compression fitting - where nut and sleeve are slipped over tubing and tightened into fitting body.

- **11A05-42:** connects 1/4" female pipe thread to 1/4" O.D. tubing.
- **11A05-61:** connects 1/8" female pipe thread to 1/8" O.D. tubing.
- **11A05-63:** connects 3/8" female pipe thread to 3/8" O.D. tubing.
- **11A05-64:** connects 1/2" female pipe thread to 3/8" O.D. tubing.

Vent Limiting Device: vLimiter®

Optional automatic vent limiting device - ball check permits unobstructed inhalation for fast regulator diaphragm response on opening cycle, but limits gas escape-ment to within ANSI standards should a diaphragm rupture.

NOTE: When using the vent limiting device, regulator must be mounted in a horizontal upright position.

- **12A04:** CSA certified for up to 1/2 psi (14" w.c.) inlet pressure. Use on RV48, RV52, RV53, RV61, R400(S), R500(S), R600(S) regulators. Color - brass. 1/8" NPT.
- **12A09:** CSA certified for 2 psi (LP) and 5 psi (natural) inlet pressure with 325-3 and 325-3L regulators; OPD48, OPD600. Color - green. 1/8" NPT.
- **12A34:** CSA certified with RV81. Color - brass. 3/8" NPT.
- **12A39:** CSA certified for 2 psi (LP) and 5 psi (natural) inlet pressure with 325-5 and 325-5L regulators; OPD210D. Color - brass. 3/8" NPT.
- **12A49:** CSA certified for 2 psi (LP) and 5 psi (natural) inlet pressure with 325-7A, 325-7AL, 325-9, and 325-9L regulators; OPD210E. Color - brass. 1/2" NPT.

Satisfies ANSI Standards for both Natural and LP gas.

NOTE: Vent limiters are not recommended for use in models RV91, RV111, RV131, and 210 Series.

Vent Limiting Orifice

- **12A06:** Orifice hole is on side of body, under head. Fixed orifice equally limits inhalation and escapement. Use on RV48, RV52, RV53, RV61, R400(S), R500(S), R600(S) regulators. Color- brown. 1/8" NPT.

Satisfies ANSI Standards for both Natural and LP gas.





Vent Protector: vProtector®

Designed for outdoor applications. Use on vent opening to protect breather hole from rain, snow, dust, insects and other foreign particles.

NOTE: Vent protector **MUST** be mounted in an upright position.

- **13A15:** for 1/8" NPT vent. For outdoor use in 325-3, 325-3L, RV48, RV52, RV53, RV61, R500(S)(Z), and R600(S)(Z).
- **13A15-5:** for 3/8" NPT vent. For outdoor use in 325-5, 325-5L, RV81, 210D.
- **13A25:** for 1/2" NPT vent. For outdoor use in 325-7A, 325-7AL, 325-9, 325-9L, RV91, 210E.

NOTE: NOT a vent limiting device. Consult Maxitrol regarding other configurations.

Vent Dampener

- **KVOP-3:** Used on 325-5, 325-5L.
- **KVOP-4:** Used on 325-7A, 325-7AL.

Vent Screen

Brass, 40 mesh screen flame arrestor for insertion in vent outlet. Prevents ignition of gas-air mixture which might be present in upper diaphragm chamber.

- **13A03-1:** for 1/8" NPT vent.
- **13A03-2:** for 1/4" NPT vent.
- **13A03-3:** for 3/8" NPT vent.
- **13A03-4:** for 1/2" NPT vent.
- **13A03-6:** for 3/4" NPT vent.

Pressure Tap Connector

- **PF10:** Pressure tap connector installed as part of the control. It is a hose fitting incorporating a captured sealing means for testing inlet and outlet pressures. This eliminates the need for a special barb fitting.

Dust Cap

Use on vent opening to prevent blockage of breather hole from dust or other foreign particles.

- **13A09:** for 1/8" NPT vent. Press-in plastic cap.

Tamper Proof Seals

Permanent pressure sensitive backed paper. Attempted removal of these seals will destroy the face stock, leaving adhesive residue on surface beneath. Therefore, tampering can be easily detected. Available for all threaded models. Outlet pressure printed on seal.

- **101310:** for RV12, RV20L, RV47, RV48, RV52, RV53, RV61, R400(S)(Z), RV500(S)(Z), R600(S)(Z), 325-3, and 325-5.
- **101311:** for RV81, RV91, RV111, 210D, 210E, 210G, 325-7A, 325-9.



CHOOSING A VENT ACCESSORY

NOTE: If vent limiting device is not used, regulator vent must be piped in accordance with government and local codes and regulations.

RV12L, RV20L	Integral vent limiting orifice with dust cap standard.
RV20VL	Integral vent limiting orifice with dust cap standard or use 11A08 threaded sleeve nut and run vent line as per code.
RV47	Must order: "L" suffix - Integral vent limiting orifice, includes dust cap; or "D" suffix - integral ball-check limiting device, includes dust cap.
RV48	1/8" NPT vent tap. Optional 12A04 or 12A06 vent limiter. Optional 13A09 dust cap. Optional 10A16-2 or 10A16-3 plastic thread protector.
RV48L	Integral vent limiting orifice.
RV52, RV53, RV61	1/8" NPT vent tap. Optional 12A04 or 12A06 vent limiter.
RV81	3/8" NPT vent tap. Optional 12A34 vent limiter.
RV91 (2 1/2" pipe size)	1/4" NPT vent tap. Optional 13A15 vent protector. <i>Vent limiter not approved for this model.</i>
RV91 (2" pipe size)	1/2" NPT vent tap. 2" pipe size. Optional 13A25 vent protector. <i>Vent limiter not approved for this model.</i>
RV111, RV131	3/4" NPT vent tap. <i>Vent limiter not approved for these models.</i>
210D	3/8" NPT vent tap. Optional 13A15-5 vent protector. <i>Vent limiter not approved for this model.</i>
210E	1/2" NPT vent tap. Optional 13A25 vent protector. <i>Vent limiter not approved for this model.</i>
210G, 210J	3/4" NPT vent tap. <i>Vent limiter not approved for these models.</i>
220D, 220E, 220G, 220J	Pilot regulator is equipped with 12A06 vent limiting orifice, separate vent line is not required.
325-3, 325-3L	1/8" NPT vent tap. Optional 12A09 vent limiting device or 13A15 vent protector.
325-5, 325-5L	3/8" NPT vent tap. Optional 12A39 vent limiting device or 13A15-5 vent protector.
325-7A, 325-7AL	1/2" NPT vent tap. Optional 12A49 vent limiting device or 13A25 vent protector.
325-9, 325-9L	1/2" NPT vent tap. Optional 12A49 vent limiting device or 13A25 vent protector.
R400(S), R500(S), R600(S)	1/8" NPT vent tap. Optional 12A04 vent limiting device.
OPD47	Integral vent limiting orifice, includes dust cap.
OPD48, OPD600	1/8" NPT vent tap. Optional 12A09 vent limiting device or 13A15 vent protector.
OPD210D	3/8" NPT vent tap. Optional 12A39 vent limiting device or 13A15-5 vent protector.
OPD210E	1/2" NPT vent tap. Optional 12A49 vent limiting device or 13A25 vent protector.

NOTICE

Maxitrol vent limiting devices eliminate the need to run vent piping to the outside. Vent limiting devices are designed for use indoors and in spaces where limiting the amount of gas escapement due to diaphragm failure is critical. **Vent limiting devices should not be used outdoors if they are exposed to the environment.** Vent protectors are available for all outdoor applications to ensure proper vent protection.

Dead End Lock Up

Pressure will be maintained within ANSI/CSA limits under no flow conditions. The amount of climb above set point is influenced by inlet pressure, flow rate before no flow condition and piping arrangement. Dead end lock up pressure regulators must be properly sized for desired performance.

Differential Pressure

The difference between inlet pressure to the pressure regulator and outlet pressure from the pressure regulator. To obtain differential pressure, subtract the desired outlet pressure from available inlet pressure.

Line Pressure Regulator

A pressure regulator intended for installation in a building gas distribution system between the building service regulator or LP-gas 2 psi service regulator and gas utilization equipment.

Lock Up Type

Under no flow conditions, outlet pressure will rise above adjusted pressure but will not rise to line pressure.

Minimum Capacity (Main Burner Only)

Minimum capacity of a pressure regulator designed to control the flow to the main burner only.

Maximum Capacity (Main Burner Only)

Maximum capacity of a pressure regulator at which the pressure regulator will control main burner pressure within acceptable limits.

Maximum Capacity (Main Burner and Pilot)

Maximum capacity of a pressure regulator at which the pressure regulator will control main burner and pilot line pressure within acceptable limits.

Capacity

Total load Btu/h of all appliances combined.

Maximum Individual Load

Largest single appliance or burner served by the pressure regulator.

Maximum Individual Load Capacity

1. The maximum capacity or flow at which a line pressure regulator will control lockup pressure within acceptable limits.
2. The maximum capacity or flow at which a pressure regulator will control pilot line pressure within acceptable limits.

Non-Lock Up Type

Under static conditions when no gas is flowing, outlet pressure will rise to line pressure.

Overpressure Protection Device (OPD)

A device which under abnormal conditions will act to reduce, restrict, or shut off the supply of gas flowing into a system to prevent pressure in that system from exceeding 2 psi.

- *Monitoring Regulator:* An overpressure protection device which functions as a second pressure regulator in series with the primary pressure regulator.
- *Overpressure Relief Device:* An overpressure protection device which functions by discharging gas from the downstream system to a safe location.
- *Overpressure Shut-Off Device:* An overpressure protection device which functions by completely shutting off the flow of gas into the downstream system.

Pressure Drop

The natural loss of pressure that occurs in the pressure regulator (or in any valve or pipe) due to friction. This friction impedes fluid motion, without regard to artificial losses deliberately created by diaphragm action. The equivalent flow rate for a loss in given pressure with the pressure regulator valve in a normally wide open position.

Rated Inlet Pressure

The highest inlet pressure for which the control is intended to be used.

Vent Limiter

A means that limits the flow of gas from the atmospheric chamber to the atmosphere in the event of a diaphragm rupture. This may be either a limiting orifice or a ball check vent limiting device.

- *Limiting Orifice Type:* A vent limiter where the flow through the limiter is the same in both directions

Zero Governors

They require an external impulse signal, such as top loading with pressure or generating vacuum in the downstream piping.

GF SERIES

Gas and Air Filters

Gas and air filters protect downstream controls (regulators, automatic shut-off valves) from particulate contamination.



GF60

Specifications

Pipe Sizes 1/2" to 2" threaded connections with NPT or ISO7-1 threads.

Housing Material GF40, GF60, GF80: aluminum.

Mounting Suitable for multi-positional mounting, preferably with lid facing down or to the side to facilitate removal of debris during maintenance.

NOTE: All Maxitrol gas pressure regulators should be installed and operated in accordance with Maxitrol Safety Warning Instructions (see GF_IO_EN.DE).

Certifications According to DIN 3386, Gas Appliances 2009/142/EC and Pressure Equipment Directive 97/23/EEC.

Gas Types Suitable for natural, manufactured, mixed gases, liquefied petroleum gases, LP gas-air mixtures, sewer gas, and air.

Pressure Tap Connector Optional: Pressure tap (PF10) connections inlet and/or outlet side.

Maximum Inlet Pressure 15 psi (100 kPa)

Ambient Temperature Ranges -4 to 175°F (-20 to 80°C)

Storage and Transport Temp -58 to 175°F (-50 to 80°C)

Filter Replacement Material GF40 Models: part number 101706-1
GF60 Models: part number 101706-2
GF80 Models: part number 101706-3

GF SERIES GAS AND AIR FILTERS



Dimensions

NPT Model	ISO 7-1 Model	Pipe Size	Pressure	Weight
GF40-44	GF40M-44	1/2"	100 kPa, 400 kPa	7 oz (0.2 kg)
GF60-66	GF60M-66	3/4"	100 kPa, 400 kPa	24 oz (0.7 kg)
GF60-88	GF60M-88	1"	100 kPa, 400 kPa	24 oz (0.7 kg)
GF80-1010	GF80M-1010	1 1/4"	100 kPa, 400 kPa	60 oz (1.7 kg)
GF80-1212	GF80M-1212	1 1/2"	100 kPa, 400 kPa	60 oz (1.7 kg)
GF80-1616	GF80M-1616	2"	100 kPa, 400 kPa	60 oz (1.7 kg)

Outer Dimensions				
Model	Swing Radius	A	B	C
GF40	1.6" (41 mm)	2.1" (53 mm)	2.7" (69 mm)	2.3" (58 mm)
GF60	2.6" (66 mm)	3.7" (94 mm)	4.3" (109 mm)	3.7" (94 mm)
GF80	4" (102 mm)	6.2" (158 mm)	6.2" (163 mm)	6.4" (163 mm)

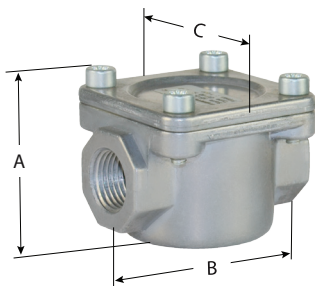

GF40

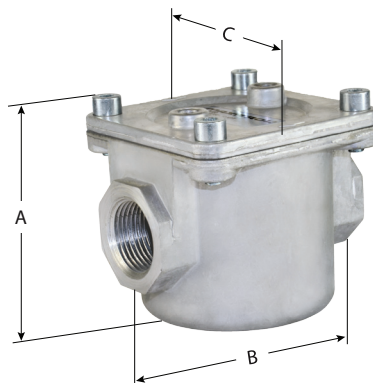

GF60

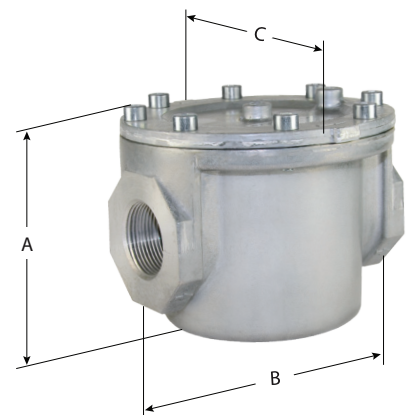

GF80

NOTES:

