

# SERIES 35-72



35.72.01

## 120 VAC Direct Spark Ignition Control Microprocessor Based

### FEATURES

- Two Mounting Configurations
  - Open Board With Stand-Off's - saves space and cost
  - Potted - protection for washdown and extreme vibration
- Multi Pin Connector - fast assembly
- 2 Trial for Ignition Options – 1 and 3 try
- 4 Trial for Ignition Times – 4, 7, 10 and 15 seconds (customized timings available)
- 2 Flame Sense Options – single spark and sense and remote sense
- Thermostat/Power Off Reset
- Line Polarity Insensitive – reduces chances of miswiring



### APPLICATIONS

- Construction Heaters
- Ceramic Infrared Heaters
- Black Body Infrared Heaters
- Commercial Cooking Equipment
- Any 120 VAC Gas Burner Application under 400K BTU

### DESCRIPTION

The 35-72 is a 120 VAC direct spark ignition control for controlling a gas valve and igniting LP or natural gas on heating equipment that provides a 120 VAC operating voltage.

The microprocessor circuit design provides precise, repeatable timing sequences for ignition times, purge times (pre- and inter-) along with multiple tries for ignition and flame sensing during pre-purge.

### Agency Certifications

Design certified by CSA International to CAN C22.2 #199-M89 and ANSI Z21.20 for Automatic Ignition Systems

### THE TOTAL SOLUTION FOR GAS IGNITION CONTROL

Fenwal offers a complete range of ignition control products including:

- Ignition Controls
- Spark and Flame Sense Electrodes
- Spark and Flame Sense Cables
- Wiring harnesses

Designed, developed and manufactured by Fenwal, these components integrate seamlessly providing maximum system performance.

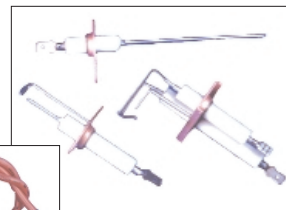

### Getting Started - Samples

To ensure proper system design and operation, Fenwal provides sample ignition controls, high-voltage wires and electrodes for trial and evaluation at no charge. To get you started quickly, Fenwal has identified our most popular ignition controls, see Page 8. Whether it is an individual control, complete start-up kit or customized control, Fenwal is ready to provide your gas ignition solution.

### Fenwal Ignition Development Center

Send your equipment to us and we'll design, install and qualify a control to meet your exact application requirements. Fully equipped and staffed with trained technicians, the Fenwal Ignition Development Center has proven extremely beneficial for many customers focused on product quality and reducing time-to-market for their appliances.

---

## SEQUENCE OF OPERATION / FLAME RECOVERY/ SAFETY LOCKOUT

### Start up - Heat Mode

When the thermostat is set above the ambient temperature, 120 VAC are supplied to the L1 terminal. When this occurs the control will power up and perform a self-check routine and begin a pre-purge\*, if selected. Following the pre-purge, the gas valve is energized and sparks commence until flame is detected or the Trial For Ignition (TFI) period expires.

When flame is detected, the spark is shut off and the gas valve remains energized. The thermostat and burner flame are constantly monitored to ensure that the system is functioning properly. When the thermostat is satisfied and the demand for heat ends, the gas valve is de-energized immediately and the flame is extinguished.

### System Response to Flame Failures

The robust design of our gas ignition controls is demonstrated by their ability to respond to flame failures in a safe manner and provide re-ignition options for the equipment designer.

### Flame Failure During Trial-for-Ignition Period

#### SINGLE TRIAL MODEL

Should the burner fail to light or flame is not detected at the end of the trial-for-ignition period, the gas valve is de-energized immediately and the control will go into lockout mode.

#### MULTI TRIAL MODEL

Should the burner fail to light or flame is not detected during the first trial for ignition period, the gas valve is de-energized and the control starts the inter-purge sequence before another ignition attempt. After inter-purge, the control will attempt two additional ignition trials. If these attempts are unsuccessful the control will go into lockout mode.

### Flame Failure of Established Flame

#### RE-IGNITION

If the established flame signal is lost while the burner is operating, the control responds and begins sparking within 0.8 seconds. The spark will be energized for the duration of the trial-for-ignition period in an attempt to re-light the burner. If flame is re-established, normal operation resumes.

#### SINGLE TRIAL MODEL

If the burner does not light after the first attempt, the control will de-energize the gas valve and go into lockout mode. See Lockout Recovery

#### MULTI TRIAL MODEL

If the burner does not light after the first attempt, the inter-purge sequence is completed between attempts to re-light the burner. If the burner fails to light after the third try, the control will de-energize the gas valve and go into lockout mode. See Lockout Recovery

### Lockout Mode (On-Board Safety System)

After single or multiple attempts to light the burner have failed or flame is not established, the control automatically enters lockout mode. The control will not open the gas valve unless there is intervention by the user. See Lockout Recovery.

### Lockout Recovery

For lockout recovery, reset the thermostat below ambient temperature or remove the 120 VAC power supply for 5 seconds.

\* The pre-purge is simply a delay to allow gas to dissipate from the combustion chamber. This control is not equipped with a combustion blower relay and therefore does not initiate a fan powered pre-purge.

## MOUNTING AND WIRING

The 35-72 is not position sensitive and can be mounted vertically or horizontally. The control may be mounted on any surface and fastened with #6 sheet metal screws. Secure the control in an area that will experience a minimum of vibration and remain below the maximum ambient temperature of 80°C (175°F).

All connections should be made with UL approved, 105°C rated, 18 gauge, stranded, .054" thick insulated wire. Refer to the appropriate wiring diagram when connecting the 35-72 to other components in the system. High voltage spark cables and control wiring harnesses are detailed on Pages 5 and 6.

### SINGLE SPARK AND SENSE

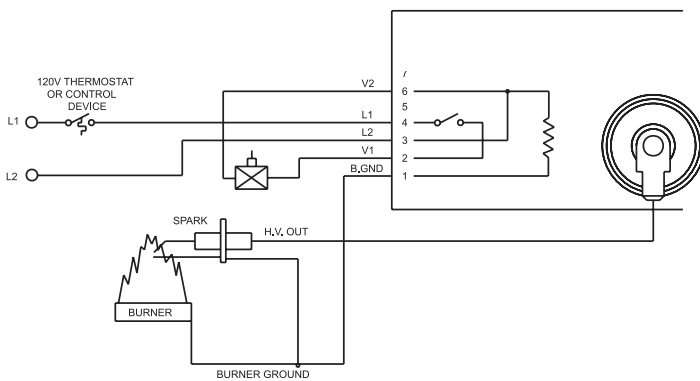

SIX PIN HEADER AMP PART NUMBER 644615-6 ON CIRCUIT BOARD. SEE PAGE 6 FOR MATCHING CONNECTORS AND WIRING HARNESSSES.

### REMOTE SENSE

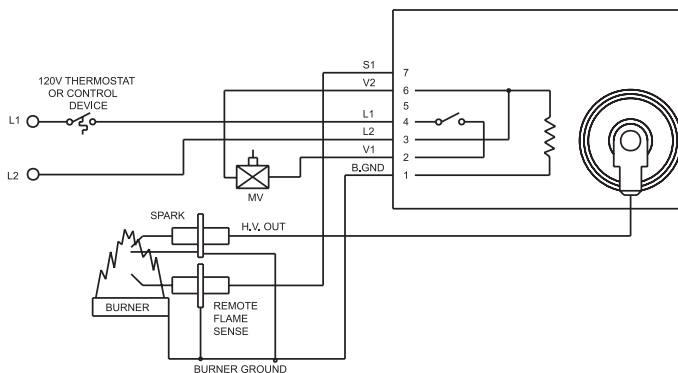

SIX PIN HEADER AMP PART NUMBER 64415-7 ON CIRCUIT BOARD. SEE PAGE 6 FOR MATCHING CONNECTORS AND WIRING HARNESSSES.

## Terminal Designations

TERMINAL	DESCRIPTION	PIN LOCATION	WIRE COLOR
<b>Single Spark and Sense</b>		<b>6-Pin Connector</b>	
B. Gnd	Burner Ground	1	Purple
V1	Valve Power	2	Brown
L2	Line Neutral	3	White
L1	120 Vac Input (Hot)	4	Black
Not Used		5	
V2	Valve Neutral	6	Yellow
<b>Remote Flame Sense</b>		<b>7-Pin Connector (same as above plus pin 7)</b>	
S1	Remote Flame Sensor	7	Gray



### CAUTION:

Label all wires prior to disconnection when servicing the control. Wiring errors can cause improper and dangerous operation. A functional checkout of a replacement is recommended.

## SPECIFICATIONS

Input Power	102 to 138 VAC, 50/60 Hz
Input Current Drain	50mA @ 120 VAC, 60 Hz
Gas Valve Rating	1.5A @ 120 VAC
Operating Temperature	-40°F to +175°F, -40°C to +80°C
Flame Sense Voltage	45% of line voltage
Flame Sense Current	1.0 microamp minimum
Flame Failure Response Time	0.8 seconds maximum
Type of Gases	Natural, LP and manufactured
Spark Rate	Line frequency (50/60 Hz)
Moisture Resistance	Conformal coated to operate to 95% R.H. Potted to operate up to 100% R.H.
Size (LxWxH)	See drawing on back page for details
Weight	Integral stand-offs: 2.3 oz Potted: 6.1 oz



### WARNING:

Operation outside specifications could result in failure of the Fenwal product and other equipment with injury or death to people and damage to property.

## TROUBLESHOOTING GUIDE

Symptom	Recommended Actions
Control will not start up	A. Check wiring B. No voltage @ pin 4, check thermostat C. Check fuse/circuit breaker D. Faulty control, consult Fenwal
Gas Valve on and no spark through TFI	A. Shorted electrode - re-establish 1/8" gap B. High voltage cable is disconnected C. Check wiring
Spark on and gas valve off	A. Valve coil open B. Valve wire disconnected C. Faulty control, check voltage @ pin 2
Flame during trial for ignition but no flame sense after trial for ignition	A. Check electrode position B. Check high voltage wire and connection C. Poor ground @ pin 1 D. Check flame current E. Check remote sensor wire on pin 7

# ACCESSORIES

## Proper Electrode Location

Proper location of the electrode assembly is important for optimum system performance. It is recommended that the electrode assembly be mounted temporarily using clamps or other suitable means to check the system before permanently mounting the assembly. The electrode assembly should be located so that the tips are inside the flame envelope and about 1/2 inch (10 mm) above the base of the flame. See Figures 3a and 3b.

### CAUTIONS:

1. Ceramic insulators should not be in or close to the flame.
2. Electrodes should have a gap spacing of  $0.125 \pm 0.031$  inch ( $3.12 \pm 0.81$  mm). If this spacing is not correct, the assembly must be replaced.
3. Exceeding the temperature limits can cause nuisance lockouts and premature electrode failure.
4. Electrodes must be placed where they are not exposed to the appliance user in normal operation.

## Flame Sensing

Flame sensing is achieved using the principal of flame rectification. Flame rectification relies on current passing from ground through the flame to the sense rod. The minimum flame current necessary to keep the system from lockout is 1.0 Micro Amperes DC.

### SINGLE SPARK AND SENSE

Figure 3a

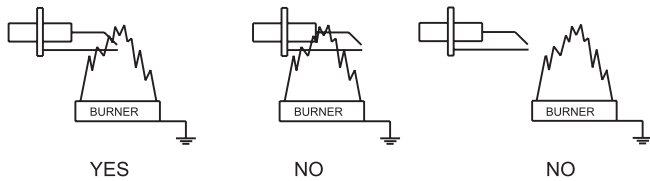

### REMOTE FLAME SENSE

Figure 3b

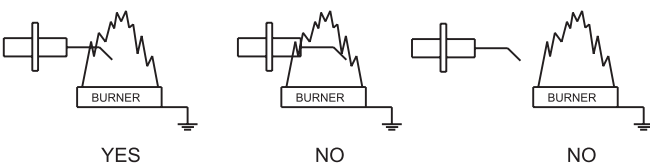

### FLAME CURRENT CHECK: SINGLE SPARK & SENSE

To measure flame current, disconnect input voltage, then insert a 0-5 Micro Amperes DC meter and capacitor in series with the spark electrode per Figure 4a. Reconnect input voltage and initiate call for heat. After sparking is complete and flame is established meter should read 1.0 Micro Amperes or higher while flame is established. If meter reads below "0" on the scale, meter leads are reversed. Disconnect power and reconnect meter leads for proper polarity.

Figure 4a

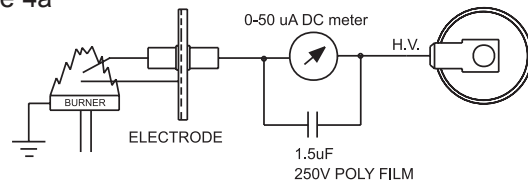

### FLAME CURRENT CHECK: REMOTE SENSE

To measure flame current, disconnect input voltage, then insert a 0-50 Micro Amperes DC meter inline with flame sense wire per Figure 4b. Reconnect input voltage and initiate call for heat. After sparking is complete and flame is established meter should read 1.0 Micro Amperes or higher while flame is established. If meter reads below "0" on the scale, meter leads are reversed. Disconnect power and reconnect meter leads for proper polarity.

Figure 4b

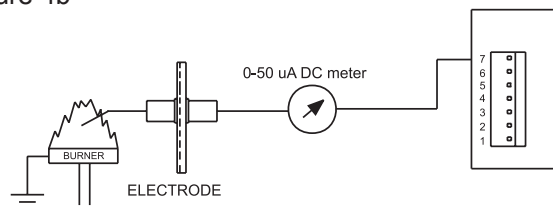

### TYPICAL SPARK ELECTRODE WITH INTEGRAL REMOTE FLAME SENSE

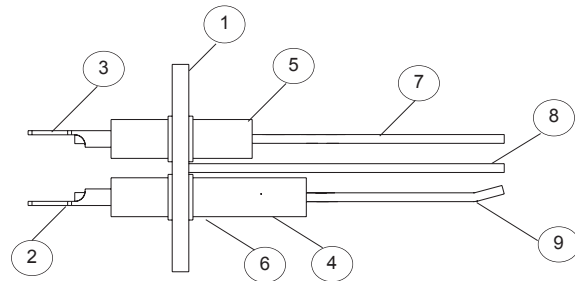

ITEM #	DESCRIPTION	STANDARD MATERIAL	HIGH TEMP MATERIAL
		CSA rated at 1800°F	CSA rated at 2500°F
1	Mounting Bracket	Steel Cu Flashed	Steel Cu Flashed
2	1/4" Q.C. High Voltage Terminal	Nickel Plated Steel	Nickel Plated Steel
3	3/16" Q.C. Flame Sense Terminal	Nickel Plated Steel	Nickel Plated Steel
4	Spark, H.V. Ceramic Tube	L-3 Steatite	Alumina
5	Sense Electrode Ceramic Tube	L-3 Steatite	Alumina
6	Press Ring	Spring Steel	Spring Steel
7	Flame Sense Electrode	Kanthal D	Kanthal APM
8	Ground Rod	Kanthal D	Kanthal APM
9	Spark Electrode, High Voltage	Kanthal D	Kanthal APM

## Electrode Assemblies

Providing over 1,000 configurations of spark electrodes and flame sense rods, Fenwal has a design for almost any application. The latest state-of-the-art wire forming and assembly equipment is used to accurately and efficiently produce high quality electrodes that deliver the hottest spark. The "Universal" electrodes depicted below are just a sampling of the 1,000 electrode styles available. These electrodes are designed for on-site customization. Cut and bend these to fit your application and then send the formed electrode back for Fenwal to detail **or** send us a print and we will provide you with a quote and samples.

### SPARK ELECTRODE WITH INTEGRAL REMOTE FLAME SENSE ROD

Part Number: 22-100000-593

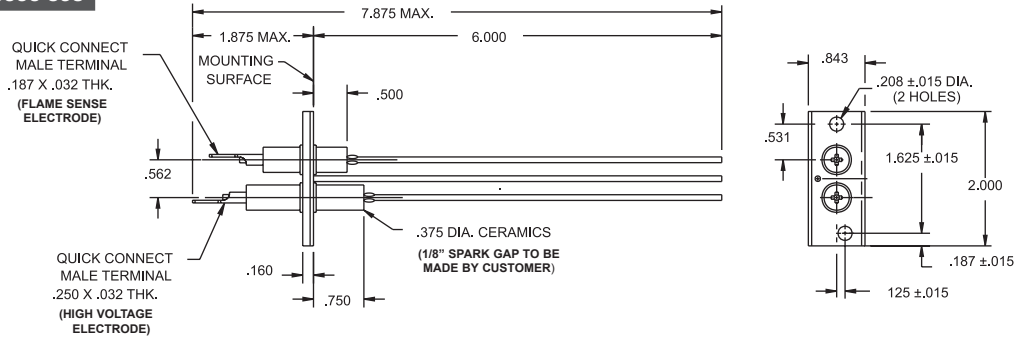

Part Number: 22-100001-076

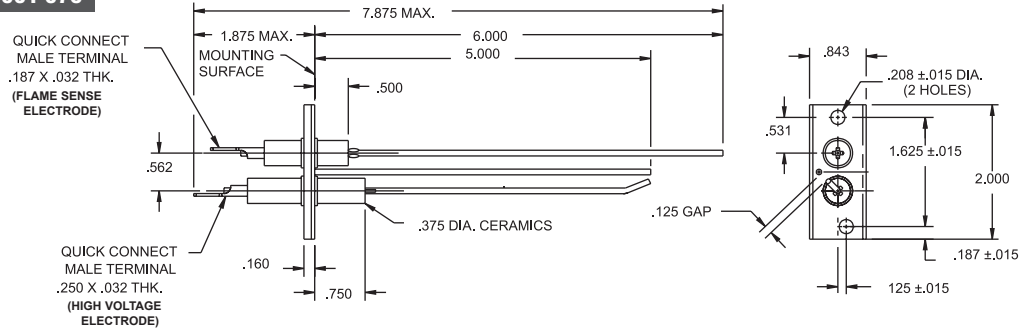

### SINGLE SPARK AND SENSE ELECTRODES

Part Number: 22-100001-117

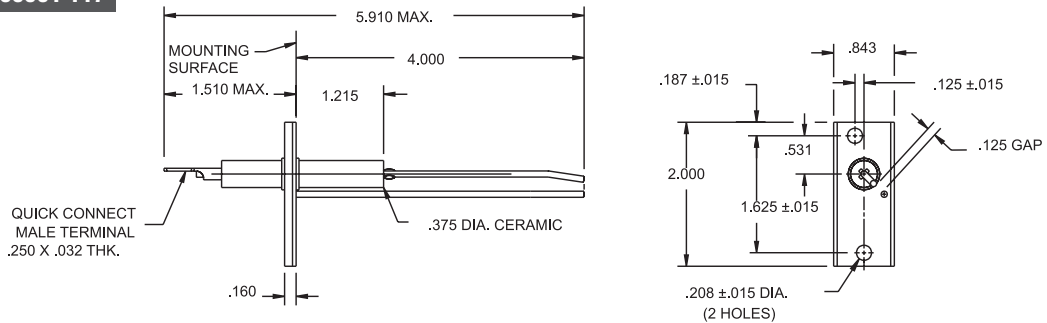

Part Number: 22-100001-025

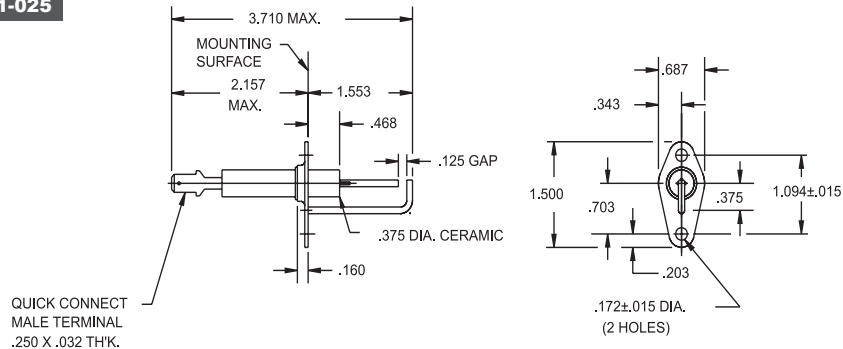

# Electrode Assemblies *continued*

## REMOTE FLAME SENSE RODS

**Part Number: 22-100001-080**

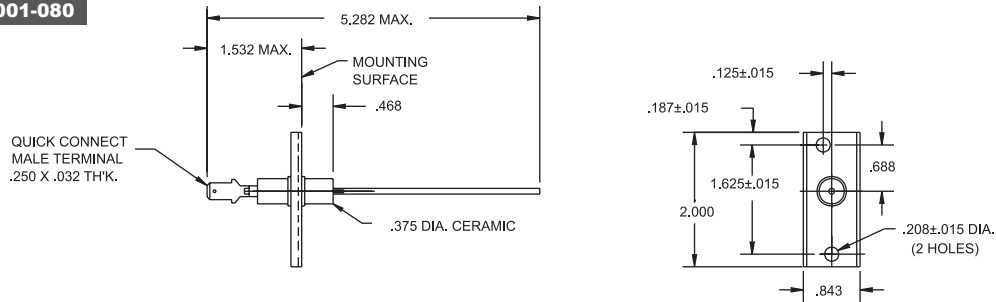

**Part Number: 22-100001-110**

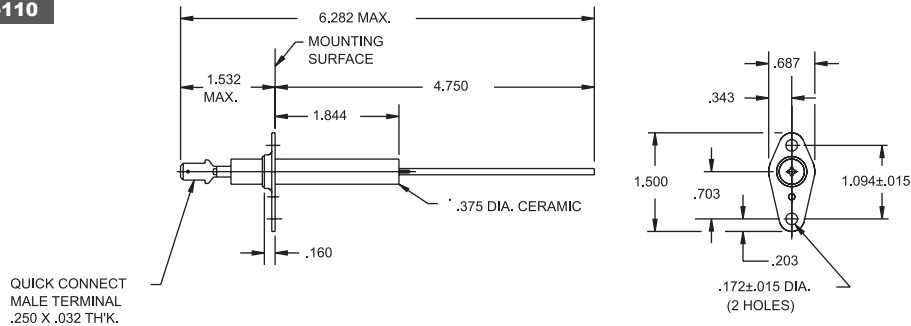

## Control Wire Harness

Select the proper harness (6 or 7 PIN) based on flame sense choice. Once the terminal configuration is determined, complete the part number by replacing the last two digits ("XX") with the length in inches ("L" dimension). Standard wire lengths are 12, 18, 24, 30, 36, 48, and 60 inches. Example: 05-129892-118 = 18 inches. For other lengths, please contact Fenwal.

SPECIFICATIONS:	Voltage Rating	Agency Rating	Temperature Rating	Diameter	Jacket Material
All Wires	600 V	UL/CSA Listed	105°C (221°F)	18 gage stranded	PVC
Gray Only	600 V	UL/CSA Listed	200°C (392°F)	18 gage stranded	PVC

## SINGLE SPARK AND SENSE

**Part Number: 05-129892-0XX**

**Part Number: 05-129892-1XX**

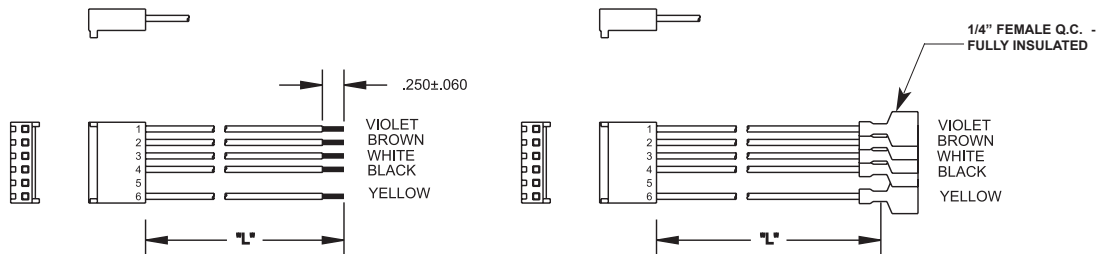

To make your own harness select AMP connector housing P/N: 770849-6 and AMP housing terminal P/N: 770552-1

## REMOTE SENSE

**Part Number: 05-129893-0XX**

**Part Number: 05-129893-1XX**

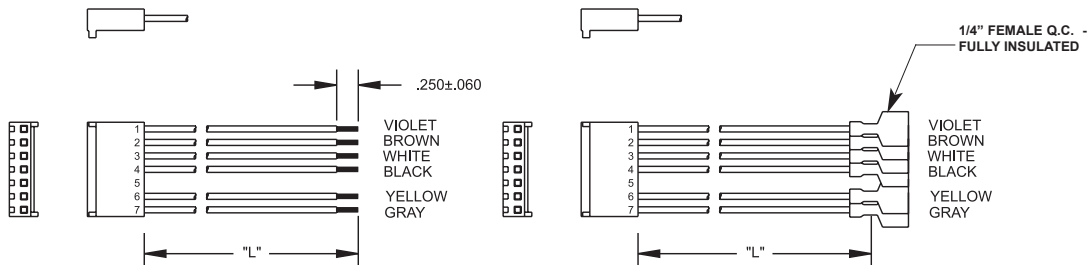

To make your own harness select AMP connector housing P/N: 770849-7 and AMP housing terminal P/N: 770552-1

## High Voltage Ignition Wire - 3 Types

Delivering the 15K to 25K volts of spark energy from the ignition control to the electrode is a vital element of an ignition system. There are 3 material options and multiple terminal configurations available. Shown are the most popular versions offered by Fenwal. To ensure maximum spark energy, it is recommended that the ignition wires not be longer than 36". Longer lengths are available and should be evaluated on the appliance to determine if there is sufficient spark energy to consistently light the burner under all conditions. Once the wire type and terminal configurations are determined, complete the part number by replacing the last two digits ("XX") with the length in inches ("L" dimension). Standard wire lengths are 12, 18, 24, 30, 36, 48, and 60 inches. For other lengths, please contact Fenwal.

**1. SILICONE RUBBER SUPPRESSION TYPE:** Resistive carbon coated fiberglass core prevents spark energy radiation from interfering with other electronic systems. Select this wire type for applications where wire lengths are less than 36" and noise is a major concern.

SPECIFICATIONS: Voltage Rating 25 KVDC      Agency Rating SAE J2031      Temperature Rating 200°C (392°F)      Diameter 7mm (.27")      Jacket Material Silicone Rubber over Fiberglass Braid

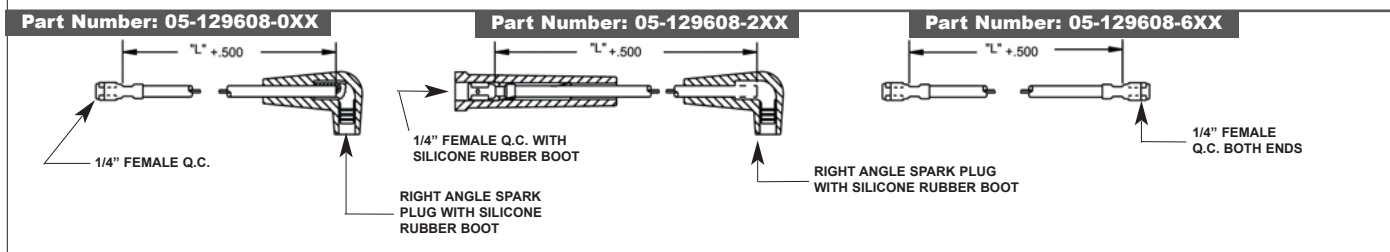

**2. SILICONE RUBBER COPPER CONDUCTOR TYPE:** Low resistance copper conductor transmits maximum spark energy. Select this type when maximum energy or longer wire lengths are required and noise is not a major concern.

SPECIFICATIONS: Voltage Rating 25 KVDC      Agency Rating UL Type 3257      Temperature Rating 250°C (482°F)      Diameter 7mm (.27")      Jacket Material Silicone Rubber

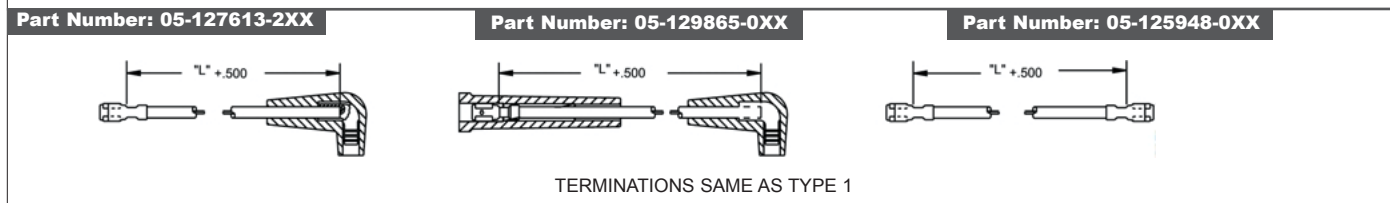

### 3. TEFLON INSULATED TYPE:

Low resistance copper conductor transmits maximum spark energy. Select this type for applications that have tight clearances and sharp bend radii.

SPECIFICATIONS: Voltage Rating 25 KVDC      Agency Rating UL Type 1911      Temperature Rating 250°C (482°F)      Diameter 2mm (.08")      Jacket Material Teflon

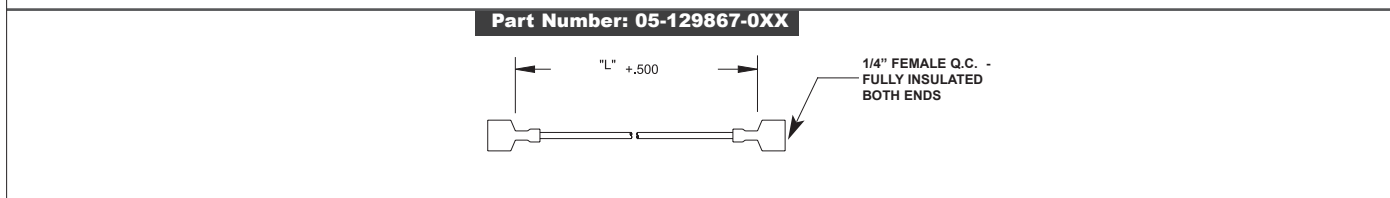

# HOW TO ORDER

# 35 - 72 5 X 0 X - X X X

## Enclosure Configurations and Wiring Options

2 = Potted Multi-Pin Connector (Figure 1)  
 4 = Integral Stand-off's Multi-Pin Connector (Figure 2)

or

## Assemblies

8 = Assemblies (may consist of control, high voltage ignition wire, electrode and harness)

or

## Non-Standard Configurations

9 = Non Standard Configuration

A 9 in this location of the part number (i.e. 35-725 901-113) identifies this configuration as a non-standard design. The part number does not follow the part numbering system. The 9XX is a sequential part number assigned by Fenwal. Consult factory for operating characteristics of this control.

## Trial for Ignition Time (TFI)

1 = 4 seconds  
 3 = 7 seconds  
 5 = 10 seconds  
 7 = 15 seconds

## Inter-Purge Time

0 = None  
 1 = 15 seconds  
 2 = 25 seconds

## Pre-Purge Time

0 = None  
 1 = 15 seconds  
 2 = 25 seconds  
 5 = 5 seconds

## Number of Ignition Trials, Flame Sense Method and Lock Out Reset Method

0 = 1 try, single spark and sense	Thermostat / power off reset
1 = 1 try, remote sense	Thermostat / power off reset
5 = 3 try, single spark and sense	Thermostat / power off reset
6 = 3 try, remote sense	Thermostat / power off reset

## MOST COMMON CONFIGURATIONS

Fenwal offers any option variation listed in the above part number scheme along with customized configurations to meet your exact application requirements. Because of the numerous options available, models not listed in the table below are made to order. For quick-ship samples and quick-ship orders, please select a model from the table below.

Ignition Control Part Number	Enclosure Type		Wiring Multi-Pin	Number of Ignition Trials		Flame Sense Method		Lockout Reset Method	Pre-purge Time (seconds)				Inter-purge Time (seconds)			Trial for Ignition Time (seconds)			
	Stand-Off	Potted		1	3	Single	Remote		0	15	30	5	0	15	30	4	7	10	15
<b>Single Spark and Sense Models</b>																			
35-725200-501		•	•	•		•		•				•	•			•			
35-725205-115		•	•		•	•		•			•		•					•	
35-725400-501	•		•	•		•		•				•	•			•			
35-725405-115	•		•		•	•		•			•		•					•	
<b>Remote Sense Models</b>																			
35-725201-501		•	•	•		•		•				•	•			•			
35-725206-115		•	•		•	•		•			•		•					•	
35-725401-501	•		•	•		•		•				•	•					•	
35-725406-115	•		•		•	•		•			•		•					•	

## POTTED

Part Number: 35-72520X-XXX

Figure 1

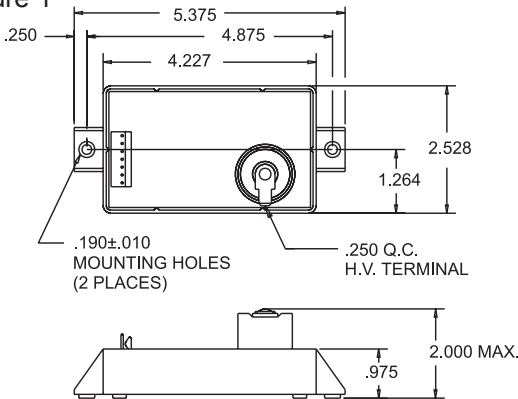

## INTEGRAL STAND-OFF

Part Number: 35-72540X-XXX

Figure 2

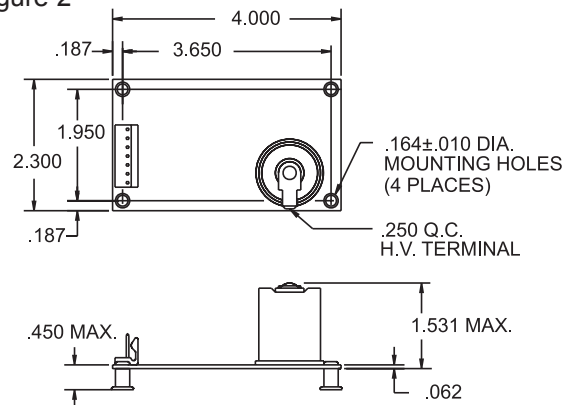

400 MAIN STREET, ASHLAND, MA 01721  
 TEL: (508) 881-2000 FAX: (508) 881-6729  
 www.fenwalcontrols.com

These instructions do not purport to cover all the details or variations in the equipment described, nor do they provide for every possible contingency to be met in connection with installation, operation and maintenance. All specifications subject to change without notice. Should further information be desired or should particular problems arise which are not covered sufficiently for the purchaser's purposes, the matter should be referred to KIDDE-FENWAL, Inc., Ashland, Massachusetts.



© 2001 Kidde-Fenwal Printed in U.S.A. CP P/N 35.72.01

Rev AA 4/30/01