



MALCO TOOL BOOK

TOOLS, FASTENERS & ACCESSORIES

Malco[®]

CONTENTS



NEW PRODUCTS	3-4
TOOL KITS	5
SIDING TOOLS: Fiber Cement	6-7
SIDING TOOLS: Vinyl	8-11
ROOFING TOOLS: Asphalt	12-13
CONSTRUCTION CLEANUP TOOLS	14-15
Magnetic Sweeps, 14-15	
Rake, 15	
GUTTER & DOWNSPOUT TOOLS	16-17
DRYWALL TOOLS	18
CAULKING GUNS	19
SNIPS: For Metal and Vinyl	20-24
SHEAR/CUTTER ACCESSORIES	25-26, 86-87
SEAMERS, FOLDING TOOLS & MINI BRAKE	27-29
AWLS, SCRIBERS & DIVIDERS	30-31
METAL DUCT TOOLS & ACCESSORIES	32-36
FIBERGLASS DUCTBOARD TOOLS	37-39
FIBERGLASS FLEX DUCT TOOLS	40-41
TUBING TOOLS	42-45
MEASURING TOOLS	46-49, 89
Levels, 46	
Chalk Lines & Squares, 47	
Rules, 48	
Measuring Wheels, 49	
Tape measure, 89	

SAWS	50-56
Hack Saws, 50	
Compass Saws, 51	
Vent Saw, 51	
Hole Saws, 52-53	
Reciprocating Saw Blades, 54-55	
Circular Saw Blades, 56	
KNIVES & BLADES	57
HAMMERS & PRY BARS	58-59
PLIERS & WRENCHES	60-62
HEX KEYS	63-64, 90
HAND DRIVERS	65-67
Screwdrivers, 65-66	
Nut Drivers, 67	
POWER DRIVES & INSERTS	68
DRILL BITS	69-70
HOLE PUNCHES	71
HAND RIVETERS	72
FASTENERS 73-77	
Rivets, 73	
Self Drilling Screws, 74-75	
Anchors, 75	
Self Tapping Screws, 76-77	
WORK ACCESSORIES	78-85
Pouches, Aprons, Knee Pads, 78-82	
Tool Boxes, 83	
Electric Cords & Lights, 84-85	
INDEX	91



A trademark of:
MALCO PRODUCTS, INC.
14080 State Hwy 55 NW
PO Box 400
Annandale, MN 55302

Inquiries: Contact Customer Service
Call: 1-800-328-3530 • Fax: 320-274-2269
www.malcotools.com • www.kenyontools.com

International Inquiries only
Contact Malco International, Inc.
14080 State Hwy 55 NW
PO Box 537
Annandale, MN 55302 USA
320-274-2376 • Fax: 320-274-2652
www.malcointl.com

All Malco tools and accessories carry a Full Warranty against manufacturing defects in materials or workmanship. Malco will replace, no charge, any tool or accessory that our examination determines to be within this warranty. Tools or accessories which are abused or worn out from normal use are excluded from this warranty.

89



"MAGNETIC TIP" TAPE MEASURE
Ideal for working with ductwork
and metal building components.

20



MAX2000 "CLASSIC GRIP"
The same great MAX
performance with a traditional
grip option.

21

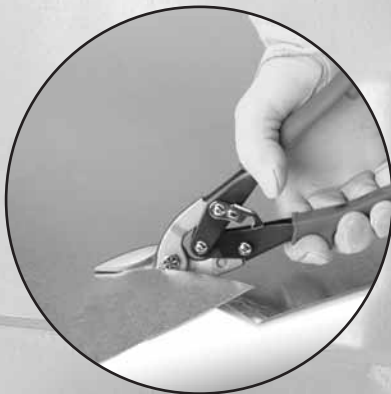

AVs AVIATION SNIPS
Traditional, compact
forged design at a price to
fit any budget.

25

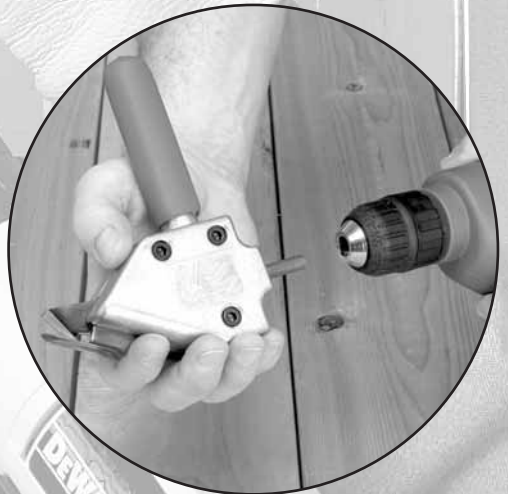

THE AMAZING TURBOSHEAR
Instantly makes your power
drill a power shear.

23

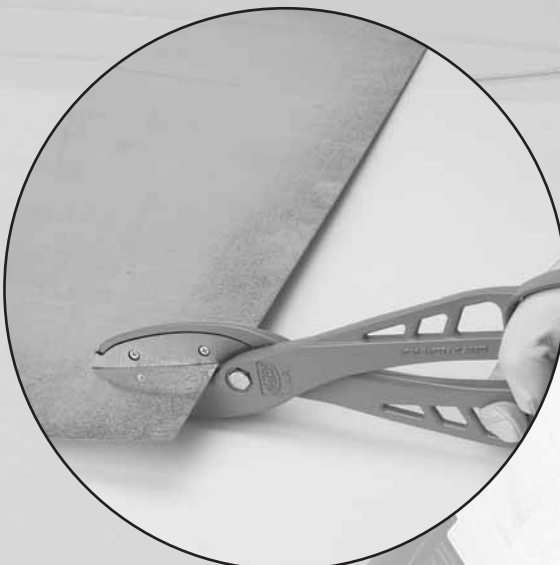

14-INCH ANDY "CLASSIC"
The fit and feel of the original
Aluminum Handled Snip with the
strength of steel.

87

OPTIONAL DRILL CLAMP
Converts original TS1
TurboShear for one-hand use.

86

HEAVY-DUTY TURBOSHEAR
Big 18-gauge capacity.
One hand operation is standard.



88

EDGE ROLLER
Makes right angle bends to 4" deep along edge of entire metal roofing or building panel.



24

VINYL-CUTTING SNIP
Specially designed to cut through the lock-seam edge of the toughest vinyl siding.



23

12-INCH ANDY "CLASSIC"
The snug fit and feel of the original Aluminum Handled Snip



6



7

FIBER CEMENT SIDING TOOLS
A full family of tools including Overlap Gauges, Facing Gauges, Notcher and Siding Nail Cutter.

HVAC Deluxe Starter Kit with FREE 1602 Tool Box

Catalog Number	Description
DSK	The following 27 tools and a FREE 1602 all steel box with tray 18" x 8" x 9" (457 x 203 x 229 mm).
C5	Pipe Crimper
SL1	Snap Lock Punch
N1	Hand Notcher
S2	Hand Seamer
12F	Folding Tool
18	Divider
M2001	Aviation Snip - left cut
M2002	Aviation Snip - right cut
M2005	Bulldog Aviation Snip
M14N	Aluminum Handled Snip
K44	10-12 Screwdriver
K56	12-16 Screwdriver
P33	No. 1 Phillips Driver
P44	No. 2 Phillips Driver
A0	1/8" (6.35 mm) Scratch Awl
A1	7/32" (5.54 mm) Scratch Awl
SH3	Setting Hammer
CT316	3/4" x 16" Tape Measure
W29	Hex Key Set
WM502	Wooden Mallet
DS2	Offset Duct Stretcher
MSH1/4	Hex Chuck
MSH5/16	Hex Chuck
ND8	1/4" Nut Driver
ND10	5/16" Nut Driver
L9M	Torpedo Level
TY4	Tie Tool



DSK



STKM

HVAC Starter Kit with FREE 1602 Tool Box

Catalog Number	Description
STKM	12 piece tool assortment and FREE 1602 all steel box with tray 19" x 7" x 7-1/2" (483 x 178 x 191 mm) .
C5	Pipe Crimper
N1	Hand Notcher
S2	Hand Seamer
SL1	Snap Lock Punch
12F	Folding Tool
18	Divider
M2001	Aviation Snip - left cut
M2002	Aviation Snip - right cut
M14N	Aluminum Handled Snip
A1	Scratch Awl
SH3	Setting Hammer
DS2	Duct Stretcher

Mini Starter Kit with free 1671 Tool Box

Catalog Number	Description
MSK	The following 11 piece core tool assortment and FREE 1671 rust proof polypropylene tool box. 16-3/4" x 8" x 7-1/2" (425 x 203 x 191 mm) .
C5	Pipe Crimper
N1	Hand Notcher
12F	Folding Tool
18	Divider
M2001	Aviation Snip - left cut
M14N	Aluminum Handled Snip
A1	7/32" (6 mm) Scratch Awl
2SW	Setting Hammer
DS2	Duct Stretcher
MSH1/4	Hex Chuck
MSH5/16	Hex Chuck



MSK



SK1

Siding Starter Kit with FREE 1671 Tool Box

Catalog Number	Description
SK1	The following 7 tools and a FREE 1671 rust proof polypropylene tool box, 163/4" x 8" x 7-1/2". (425 x 203 x 191 mm)
SL5	Snap Lock Punch, for vinyl or aluminum
MC12N	Andy, 12" (305 mm) Aluminum Handled Combination Snip
M2003	Aviation Snip, Straight, Left & Right Cutting Combo.
NHP1	Nail Hole Slot Punch, for vinyl or aluminum
SRT2	SideSwiper II, Siding Removal Tool, for Vinyl Siding
TNP2S	Trim Nail Punch, Heavy Duty Steel
4PK	Utility Knife

SIDING TOOLS: Fiber Cement



Fiber Cement Siding Overlap Gauges

Strong, one-piece tempered spring steel construction.

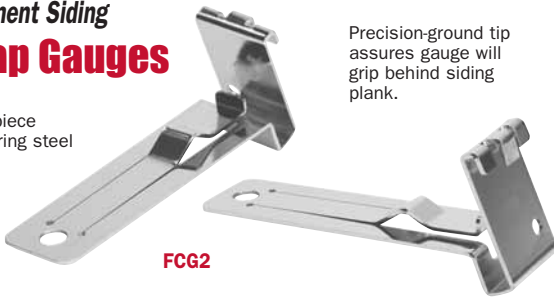

Precision-ground tip assures gauge will grip behind siding plank.

- Works with 5/16" (7.92mm) fiber cement siding.
- Permits 1-person application of siding planks by completely freeing up users hands.
- Two gauges support entire length of plank and precisely gauge a standard 1-1/4" (31.75mm) overlap in one easy step -- even on a bowed wall.
- No adjustments to vary and nothing to mark.
- Will not mar finish of pre-painted siding.

Place pair of gauges on top edge of lower plank as shown. Rest upper plank against outside face of the gauge stop to accurately space planks, and then nail upper plank approximately 18" (45.72 cm) away from gauge as shown at top of page at right.



Depress thumb tab to allow plank to snap flush to wall and gauge.

Remove gauge by depressing thumb tab again and lifting gauge up and off lower plank, then pulling gauge out from under top plank.

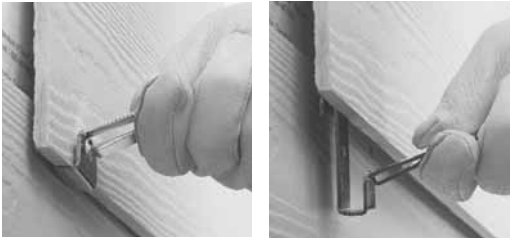

Catalog Number	Description
FCG2	Fiber Cement Siding Overlap Gauges, (1 pair)
FCGD	Fibercement Gauge Dispensing display

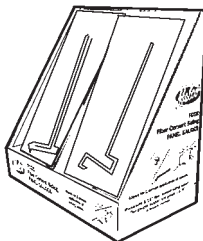

Fiber Cement Siding Facing Gauge

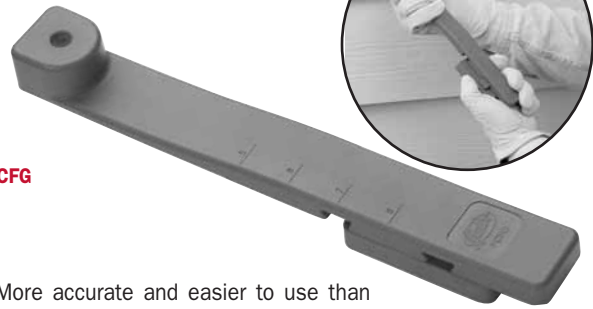

FCFG

- More accurate and easier to use than home-made wood "preacher" blocks.
- Adjustable for precise 5", 6", 7" or 8" (127.0, 152.4, 177.8 or 203.2 mm) exposures. Gauging block easily snaps into desired exposure position without use of tools or fasteners.
- Easily held with one hand while steadying new plank for nailing.
- May be used with Overlap Gauge for 1-person application (see No. FCMS Mixed Gauge Set).
- Manufactured of tough, long-lasting, weather-resistant nylon material throughout.



Using the Facing Gauge while working across the width of the plank assures greater accuracy of the desired exposure and guards against sagging. The Facing Gauge may also be used in combination with the Malco Overlap Gauge to prop up one end of the plank for one-person application.

Catalog Number	Description
FCFG	Fiber Cement Siding Facing Gauge

MIXED GAUGE SET	
FCMS	One Facing Gauge and One Overlap Gauge



No. FCMS Mixed Set

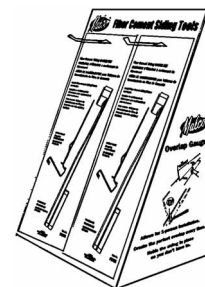



Fiber Cement Siding Notcher

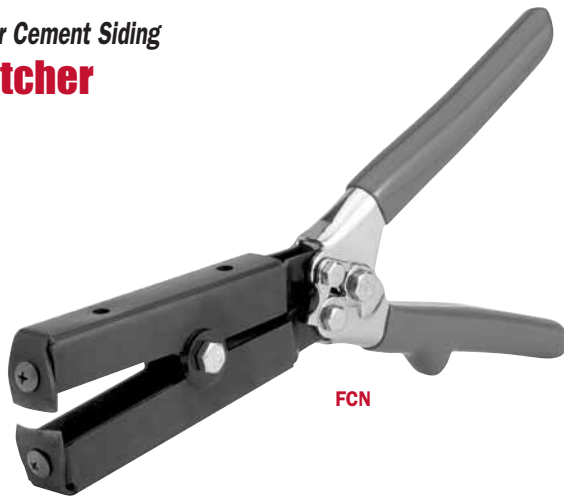

FCN

- Scores and cuts arcs up to 4" (101.6mm) diameter in fiber cement siding planks.
- Allows for plumbing, electrical, venting or other outlets to pass through siding plank.



Mark the arc of outlet diameter to be removed from plank.



Use Notcher to score along marking to avoid fractures outside arc.



Notcher may then be used to cut all the way through plank along pre-scored line.



Catalog Number	Description
FCN	Fiber Cement Siding Notcher

Replacement Spring for Hand Tools

5018	Fits C4, C5, FCN, JCC, JCC50, JCC75, N1, N2, NHP1, S2, S3, S5, S6, S9, SC3, SL1, SL2 AND SL8
------	--

Siding Nail Cutter



SNC

- Cuts hidden nails left-over from removal of damaged or unwanted fiber cement siding plank without damaging overlapping plank.
- Flat head with beveled leading edge easily maneuvers under edge of siding and into corners.
- Ideal for remodeling or salvaging projects.
- Precision-ground, heat treated jaws and compound handle leverage combine to cut up to 16D common nails.

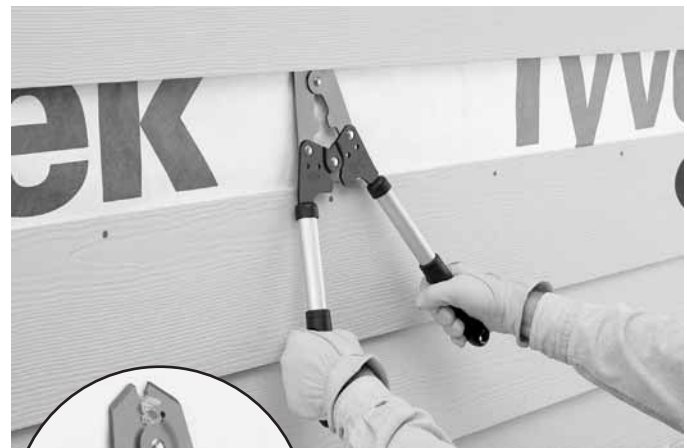

Catalog Number	Description
SNC	Siding Nail Cutter



WARNING

Do not use for cutting hardened nails or bolts.





1 INSERTION: Wedge tip of blade under overlapping panel and hook onto the back lip of buttlock.

2 UNLOCKING: Pulling lip downward, slide the tool along length of panel to unlock and expose nail row of panel to be removed.

3 PANEL REPLACEMENT: Lock and nail replacement panel into place. Use tool to relock overlapping panel. Pull down on panel lip and press it into lock of replacement panel below.



SideSwiper® II

SIDING REMOVAL TOOL
Durable one-piece steel design.

Easy-to-grasp
STRAIGHT
HANDLE.



NON-SLIP TEXTURED GRIP
permanently bonded
to handle.

SMOOTH UNLOCKING
Offset blade hooks onto siding lip securely, without
hanging up in material.

SRT2

SideSwiper model SRT2 combines the comfort and added leverage of an easy-to-grasp straight handle with the smooth unlocking motion of a burr free hook. The blade of the SRT2 is angled from the bottom plane of the handle and allows the user to keep the wrist straight while keeping knuckles well above the work. Blade surface finishing and plating assures that the sharply angled hook will not cut into the vinyl material or produce shavings.

Additional comfort and control is achieved with a non-slip textured handle grip. The gripping surface will not become slick from moisture, and the form fitting, plastisol dip process bonds the grip for the life of the tool.

Durable one piece spring steel construction is virtually indestructible. A handy oversize hang hole in handle accommodates a 1/4" peg hook.

Catalog Number	Description	Length in. (mm)	Net Wt. oz. (g)
SRT2	Siding removal tool	6-1/4 (159)	3 (85)
SRT2B	Siding removal tool bulk (25)		

The Original Malco

SideSwiper®

SRT1



Wide body and comfortable vinyl gripped handle protects knuckles and offers leverage and control needed for replacing siding panels.

Durable one piece, spring steel construction is virtually indestructible.

Catalog Number	Description	Length in. (mm)	Net Wt. oz. (g)
SRT1	SideSwiper Tool	4-1/4 (108)	1 (28)
SRT1B	SideSwiper Tool bulk (25)		

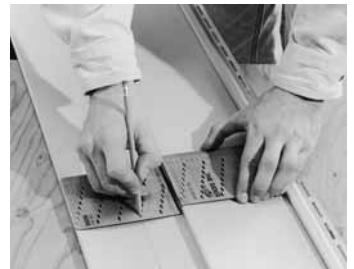
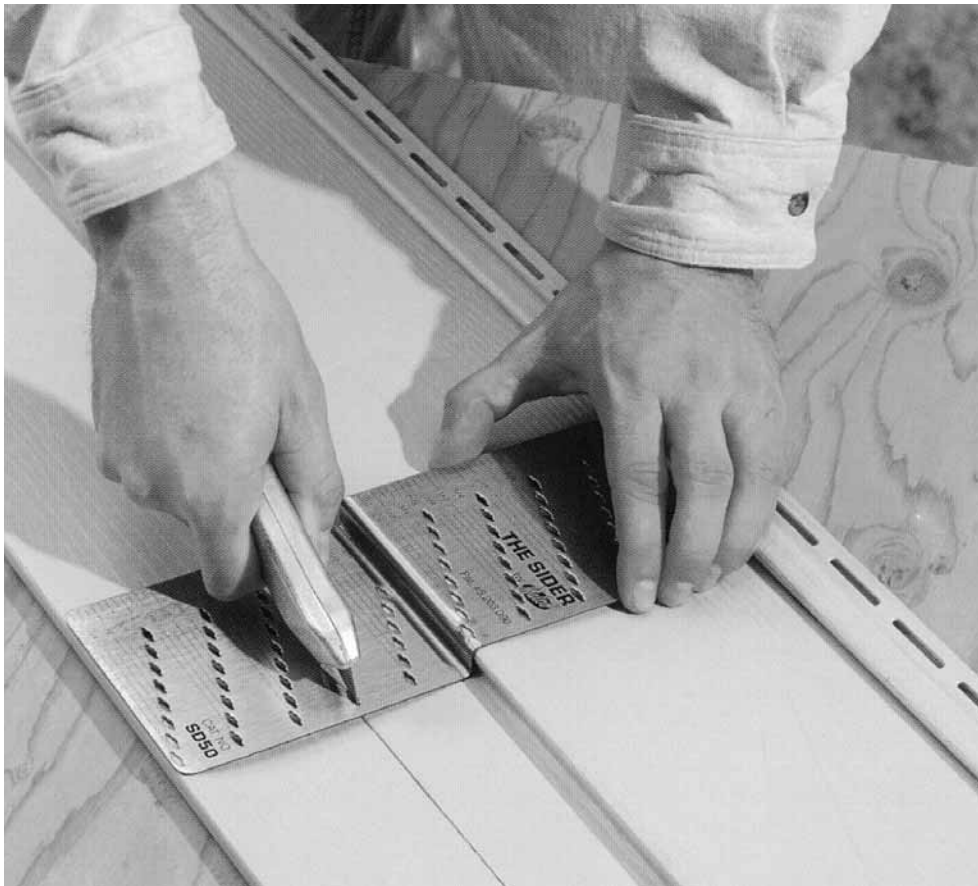

Scribe It



Square It



Cut It

THE SIDER[®] Marking, Cutting Template

The Sider Pays For Itself On The First Job!

Save up to 3 profitable hours on each job with the innovative Sider. It works quickly and accurately, replacing chalk lines, squares and straight edges. Use it as a scribe or square to mark or score precise lines. Or go straight to cutting with your utility knife in the precisely marked 1/8" holes. The Sider comes in 5 sizes to match popular siding profiles and features durable stainless steel 18 gauge construction. It's one smart little tool for even the biggest siding jobs.

Choose from 5 Sider sizes to fit most siding panel styles.

Catalog Number	Description	Net Wt.
SD40	Sider Double 4	7 oz.
SD50	Sider Double 5	8 oz.
SDL45	Sider Dutchlap 4-1/2	7 oz.
SDL50	Sider Dutchlap 5	8 oz.
SDT30	Sider Triple 3	8 oz.



SD40
Sider Double 4"



SD50
Sider Double 5"



SDL45
Sider Dutchlap
4-1/2"



SDL50
Sider Dutchlap
5"



SDT30
Sider Triple 3"



THE SIDER[®]
by *Malco*

Snap Lock Punches

For Vinyl & Aluminum Siding, Mobile Home Skirting



SL5

Snap lock plastic skirting and siding to finishing trim. Makes tabs in the cut edge of siding panel used as a finishing course at top of wall or below window. Tabs lock into utility trim.* Punch raises a high projection to compensate for natural relaxation of vinyl plastic. It also works well on aluminum siding but is not recommended for steel.

Catalog Number	Throat Depth in. (mm)	Length in. (mm)	Net Wt. oz. (g)
SL5	3/8 (9.53)	9 (229)	12 (340)

*NOTE: The SL5 should not be used when PERMATABS are required to snap into finished trim. For this application we recommend using the Malco SL1 or SL2 Snap Lock Punch. PERMATABS is a trademark of C & H Enterprises. Not Recommended for use below 32° F (0° C).

For Vinyl Only



SL8



For securing vinyl skirting and siding to finishing trim. The SL8 produces wider, more secure locking tab projections. Tabs grip a greater surface area and guard against dislodging due to relaxation of vinyl from heat. SL8 installations also resist blowout during times of high pressure and wind. Constructed of steel stampings and rugged investment cast alloy steel jaws. Nickel plate and black oxide finish with compound leverage design and red vinyl cushion grips. Not Recommended for use below 32° F (0° C).

Catalog Number	Throat Depth in. (mm)	Length in. (mm)	Net Wt. oz. (g)
SL8	1/2 (12.70)	8-1/2 (216)	16 (454)

Replacement Spring for Hand Tools

5018	Fits C4, C5, FCN, JCC, JCC50, JCC75, N1, N2, NHP1, S2, S3, S5, S6, S9, SC3, SL1, SL2 AND SL8		
------	--	--	--

Nail Hole Slot Punch



NHP1

The NHP1 punches a generous 5/32" x 3/4" horizontal slot for adding or elongating nail holes in vinyl and .019 aluminum siding to accommodate irregular stud spacing.

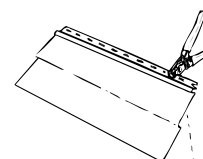

Catalog Number	Slot in. (mm)	Throat Depth in. (mm)	Length in. (mm)	Net Wt. oz. (g)
NHP1	5/32 x 3/4 (3.97 x 19.05)	5/8 (15.88)	8-1/2 (216)	16 (454)

Replacement Spring for Hand Tools

5018	Fits NHP1 and SL8 (see SL8 for full list.)
------	--



TNHP

Trim Nail Hole Punch

A 1/4" x 1/8" slot is absolutely no bigger than what you need for supporting vinyl or aluminum soffit and fascia without risking buckling of material from temperature changes. And a narrow profile head, extra wide opening jaws and a big 2 inch throat assures that you can make trim nail hole slots exactly where you need them, - not where you see them.

The TNHP punch easily fits inside soffit contours or over the lip edge of fascia. The result is a clean professional installation that is as easy to look at as the tool is to use. Built for long service it features Malco's signature compound leverage handles and comfortable vinyl grips and hand stops. Not recommended for use with some styles of stainless steel trim nails.

Catalog Number	Slot in. (mm)	Throat Depth in. (mm)	Length in. (mm)	Net Wt. oz. (g)
TNHP	1/4 x 1/8 (6.35 x 3.18)	2 (50.80)	10 (254)	18 (510)



J-Channel Cutters

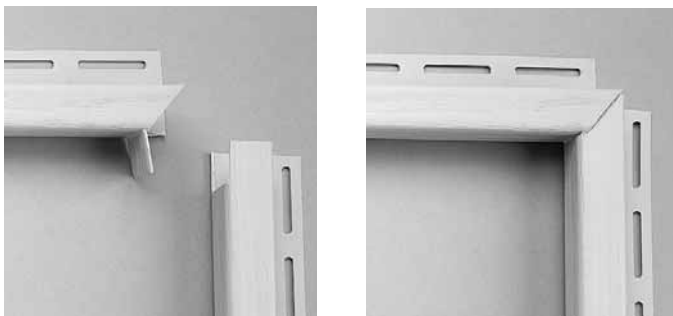

Now there are Malco J-Channel Cutters for 1/2 inch, 5/8 inch and 3/4 inch channel. Get professional results on every job with professional tools for every job! Grips are color coded for easy tool identification. **All Malco J-Channel Cutters feature a handy stop gauge to adjust cutting depth for various profiles.** And all Malco J-Channel Cutters feature compound leverage for smooth and easy cutting action plus, comfortable vinyl grips and hand stops. Durable all steel construction and rust resistant nickel chrome and black oxide finishes prolong the life of these tools.

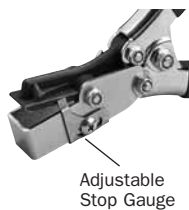

Catalog Number	Description	Grips	Overall Lgth. in. (mm)	Net Wt. oz. (g)
JCC50	1/2" (13 mm) J-CHANNEL CUTTER	Red	8-7/8 (225)	16 (454)
JCC	5/8" (16 mm) J-CHANNEL CUTTER	Blue	8-7/8 (225)	16 (454)
JCC75	3/4" (19 mm) J-CHANNEL CUTTER	Black	8-7/8 (225)	16 (454)

Replacement Spring for Hand Tools

5018 Fits JCC50, JCC, JCC75 (see page 10 for full list.)

HEAVY DUTY Trim Nail Punches

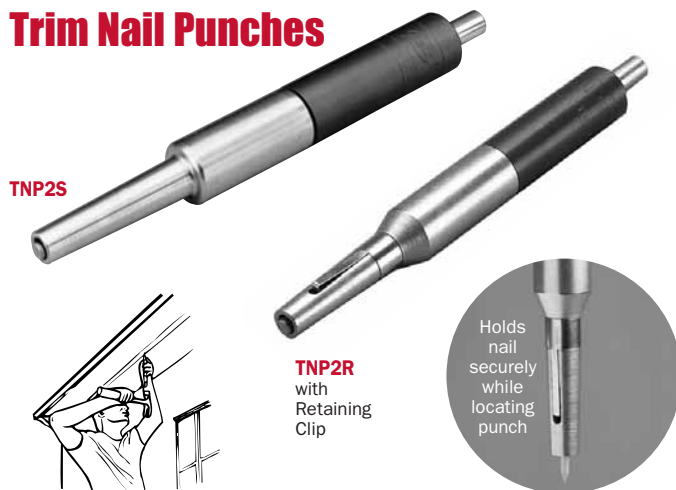

Drive trim nails into soffit, fascia and other finishing trim without denting or marring material. All steel nose and aluminum tail piece directs weight of this punch to the working end when grasping or starting a nail. Accommodates up to 1-1/4" standard trim nails. Nose fits into 1/2" J channel.

Catalog Number	Description	Length in. (mm)	Net Wt. oz. (g)
TNP2S	Trim Nail Punch	8 (203)	6 (170)

Trim Nail Punch with Nail Retaining Clip

For easier nailing from any angle or height, Malco now offers a Trim Nail Punch with an exclusive, new "nail retaining clip" feature. Avoid the awkwardness and strain of balancing nails in the nose of the punch or holding back the drive pin while standing on a ladder or reaching out to nail. The new retaining clip also minimizes scrapes and dents caused by nail slippage or improper setting depth.

Catalog Number	Description	Length in. (mm)	Net Wt. oz. (g)
TNP2R	Trim nail punch w/clip	6-3/4 (171)	6 (170)
TNP2CL	Replacement nail clip		

MINI-SIZE Trim Nail Punch

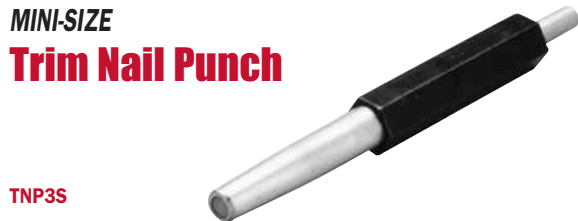

Pocket size punch is constructed of hardened steel, the tool will hold and install standard 1-1/4" trim nails. Small size allows easy access to recesses of formed trim pieces. Hex collar prevents rolling when tool is set down. Corrosion resistant.

Catalog Number	Description	Length in. (mm)	Net Wt. oz. (g)
TNP3S	Trim Nail Punch	5 (127)	2 (57)
TNP3SB	Trim Nail Punch bulk (24)		
TNP3SH	Trim Nail Punch bulk (100)		



Shingle removal is a beast of a job but now, finally, there's a tool that's up to the task. THE BEAST Shingle Remover from Malco makes a tough job bearable. THE BEAST cleanly lifts off heavy loads of shingles and pulls nails in one motion. Long handled models are available with either an **adjustable head** for handling any roof pitch, or a versatile **fixed head**. Adjustable models also feature fiberglass handles and a choice of 48 or 58 inch tool lengths. All long handled BEASTS feature replaceable 10 gauge tempered steel blades with **variable length teeth**. A comfortable D-grip is also standard.



Extra long teeth get under shingles.



Aggressive short teeth pull nails.



Handle those tight spots with a **short handled BEAST**! For steep pitched roof caps and hard to get at dormers, overhangs, valley flashing and flashing around structures, this compact tool is indispensable. The short handled BEAST also features extra side slots for pulling out nails along walls and from under trim. And the one piece steel integral handle is covered with a comfortable foam grip.

Fixed Head

- Rugged 48 inch long all steel BEAST.
- Durable 10 gauge blade is also replaceable.
- Fixed pitch angle of head is versatile for most shingle removal tasks.



Steel Handle.
48 inch Tool Length.

SB48

Variable Length Teeth. Extra long teeth get under shingles. Aggressive short teeth pull nails.

Replaceable Blades



Adjustable Head

- 3 position head makes this BEAST ideal for handling any roof pitch.
- Choice of 48 or 58 inch tool length.
- Heavy duty, but lighter weight, fiberglass handle for exceptional balance and control.

SB48A



Adjustable Position 1



Adjustable Position 2



Adjustable Position 3

Short Handled Beast

- For roof cap removal and hard to get at dormers, overhangs, valley flashing and flashing around structures.
- Beveled side slots pull out nails along walls and from under trim.



Durable
Cushion Grip

Beveled Side Slots

SB24

One-Piece Steel
Construction



Catalog Number	Head	Tool Lgth. in. (m)	Handle	Net Wt. lbs. (kg)	Replacement Blade	Replacement Handle
SB48	Fixed	48 (1.22)	Steel	6.9 (3.13)	SBRB	-
SB48A	Adjustable	48 (1.22)	Fiberglass	7.1 (3.22)	SBRB	SB48ARH
SB58A	Adjustable	58 (1.47)	Fiberglass	7.8 (3.54)	SBRB	SB58ARH

Short Handled Beast

SB24	Fixed	24 (0.61)	Steel	2.8 (1.27)	N/A	NA
-------------	-------	-----------	-------	------------	-----	----

Shingle Shovel

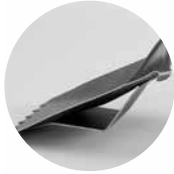

Fulcrum for lifting heavy loads.

- Thick 14-gauge steel.
- Heavy-duty teeth pry up nails.
- Deep-set, fine-grained wood handle.
- Rivet reinforced head-to-handle connection.



Catalog Number	O/A Length in. (cm)	Net Wt. lbs. (kg)
SSW	58.0 (147.3)	4.8 (2.18)

Shingle Fork



- Forged steel head.
- Fiberglass handle.
- Rivet-reinforced head and handle connections.
- Solid-molded D-grip.

Catalog Number	O/A Length in. (cm)	Net Wt. lbs. (kg)
SFF	41.5 (105.4)	4.1 (1.86)

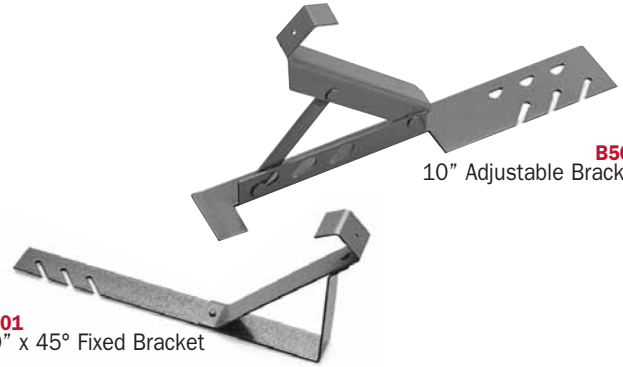

B500
10" Adjustable Bracket

B501
10" x 45° Fixed Bracket

Roof Brackets

Use 10" brackets with wood planks to create a platform that the roofer can walk or stand on. The platform can also support tools and materials. Our 4" and 6" brackets are designed to hold tools and material only.

- Durable all steel construction.
- Easy installation and removal without damaging the shingles.
- 10" Capacity: 1 man per 8 foot staging plus 40 lbs. of tools or materials. Maximum 8' spacing between brackets.
- 4" and 6" Capacity: 250 Lbs. of tools or materials only. Maximum 8' spacing between brackets.

Catalog No.	Description
B500	10" (254 mm) Adjustable Roof Bracket
B501	10" (254 mm) x 45° Fixed Roof Bracket
B502	6" (152 mm) x 90° Fixed Roof Bracket
B503	6" (152 mm) x 60° Fixed Roof Bracket
B504	6" (152 mm) x 45° Fixed Roof Bracket
B505	4" (102 mm) x 90° Fixed Roof Bracket

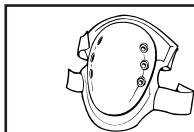

RELATED ITEM

Soft Cap Knee Pads
See Page 82

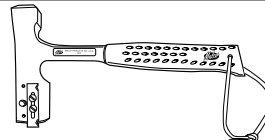

RELATED ITEM

Shinglers Hammer
See Page 59

CONSTRUCTION CLEANUP TOOLS: Magnetic Sweeps



WHEELED Magnetic Sweeps

Picks up a wide path of nails and other metal debris.



Rotational Quick Release.



Powerful Magnets attract and retain metal debris.

MS24WH

"Wheeled" models equipped with collection hoppers are available in 24 and 34-inch sweep widths.

Wheeled Model features T-Handle with Cushion Grips.



Heavy Duty Torsion Spring.

Stainless Steel Axle

U.S. Patent No. 6,113,169



Quick Release rotates housing toward hopper.



Wiper Blade clears debris off housing and directs it into removable hopper.

WHEELED MAGNETIC SWEEPS

Wheeled Magnetic Sweeps easily navigate uneven terrain while attracting and retaining metal debris. The **4-inch diameter magnet housing** is designed to freely rotate on a stainless steel axle. There is no need for height adjustment. The cylindrical housing turns slightly as obstacles are encountered to prevent captured debris from being wiped off during use. The Wheeled Sweeps' **rotational quick release** allows material to be removed from the tool quickly and easily. A **heavy duty torsion spring** returns magnetic surface of housing to down position after debris is released. A large capacity **collection hopper** allows multiple releases of debris without having to travel to a common dumping location. **Permanent magnets assure long service life** and resistance to shock and vibration. Magnets are also replaceable. A **T-handle with cushion grips** offers superior maneuverability and control. Wheeled Magnetic Sweeps come in 24 and 34-inch widths.

Removable Collection Hopper

The hopper feature allows multiple releases of debris without having to travel to a common dumping location. The quick release mechanism rotates the cylindrical housing toward a wiper blade that clears debris off the housing and directs it into the large capacity hopper. Filled hopper is easily lifted off the sweeper frame by hand and emptied.

Catalog Number	Magnetized Cylinder Housing Dimensions in. (mm)	Hopper Dimensions in. (mm)	Tool Length in. (m)	T-handle Width in. (mm)	Net Wt. lbs. (kg.)	Replacement Magnets	Replacement Wiper Blade
Wheeled Magnetic Sweep with Hopper							
MS24WH	4" dia. x 24 (102 x 610)	25-1/2 x 3-7/8 x 3-3/8 (648 x 98 x 86)	51 (1.30)	18 (457)	22 (9.98)	MS24RK	MS24WHRW
MS34WH	4" dia. x 34 (102 x 864)	35-1/2 x 3-7/8 x 3-3/8 (902 x 98 x 86)	51 (1.30)	18 (457)	28 (12.70)	MS34WHRK	MS34WHRW



CONSTRUCTION CLEANUP TOOLS: Rake

HAND HELD Magnetic Sweep



"Hand held" 12-inch sweep reaches into confined areas.

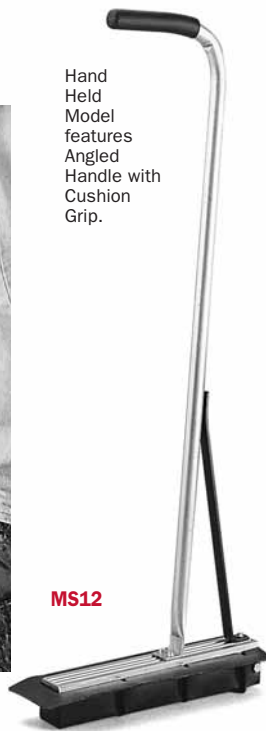

Hand Held Model features Angled Handle with Cushion Grip.

MS12

Comfortable angled handle grip projects magnet forward and to the side of user **for handy reach into confined areas** yet keeps entire magnetic surface close to ground for efficiently picking up metal debris. **Permanent magnets assure long service life** and resistance to shock and vibration. Magnets are also replaceable. **A contoured quick release sleeve** allows debris to be easily removed from tool.



Powerful Magnetic Surface efficiently picks up debris.



Quick Release Sleeve allows debris to be easily removed.

Catalog Number	Magnetized Sleeve Housing Dimensions in. (mm)	Tool Lgth. in. (mm)	Net Wt. lbs. (kg)
MS12	12 x 1-7/8 x 1-5/8 (305 x 48 x 41)	34-1/2 (876)	5 (2.27)

Replacement Parts

MS12RK	Magnets
MS12RS	Replacement Sleeve

CONSTRUCTION Cleanup Rake

Heavy-Duty Performance in an Ultra Lightweight Design
Great for ROOFERS!



BIG 66" OVERALL LENGTH

OVAL HANDLE FOR COMFORT AND GREATER LATERAL CONTROL

FORM-FIT, WRAP-AROUND BRACE CONNECTION TO HANDLE.

CR30

VERSATILE 30" HEAD



CURVED TEETH are aggressive yet easy to control for fast jobsite cleanup.

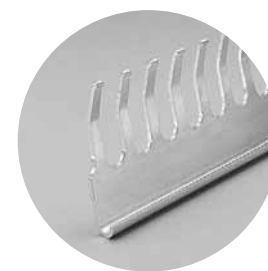
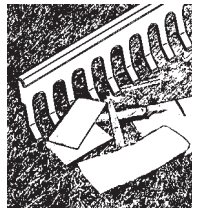

ROUNDED GRADING EDGE for smoothing and leveling pea gravel and ballast rock.

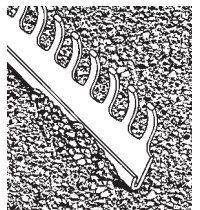

Strong yet lightweight all-aluminum rake is fully braced for non-twisting, non-turning stability. An oval handle shape gives added comfort and control. The versatile 30-inch head width and a big 66-inch reach are efficient for gathering manageable loads of debris in just one or two strokes. And a round grading edge is perfect for smoothing and leveling pea gravel and ballast rock.

Catalog Number	Head Width in. (mm)	Teeth	O/A Length in. (mm)	Net Wt. lb. (kg)
CR30	30 (762)	30	66 (1676)	3.10 (1.41)

Ships KD = Knock Down

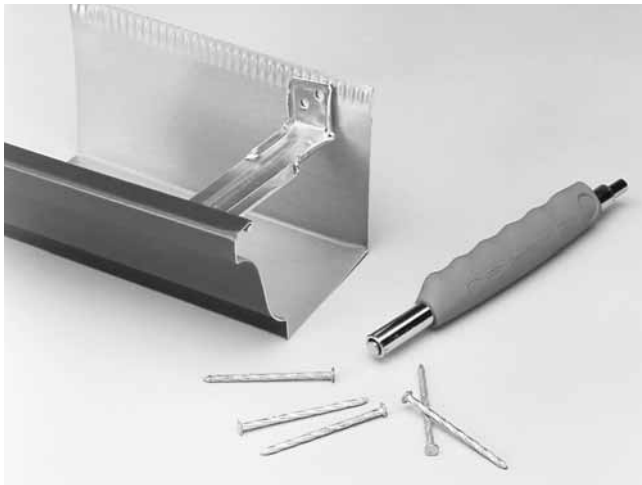

GND

Gutter Nail Driver

Works anywhere to attach gutter to fascia with ease.

Use the Malco Gutter Nail Driver with hidden hangers and 8D galvanized nails to hang aluminum or steel gutters. A non-slip ergonomic grip provides multiple positions for grasping tool and working from above or below roof overhang. Durable 2-piece steel construction plus weather resistant zinc and nickel plating assure long service life of this professional quality tool.

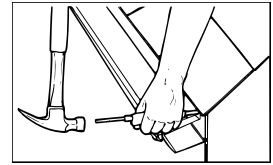

WORKING FROM ABOVE

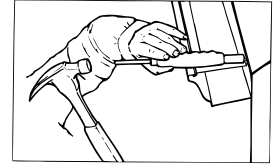

WORKING FROM BELOW

Catalog Number	Description	Length in. (mm)	Net Wt. oz. (g)
GND	Gutter Nail Driver	7-5/8 (194)	7 (199)



SL2

Snap Lock Punch

Ideal for crimping end caps on gutter.

Slide adjustment for throat depth allows settings from 1/4" to 5/8" depth. Also used to crimp end caps on gutter. Nickel plate and black oxide finish. Green grips. Formed metal cutting jaws.

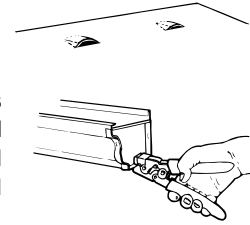

Catalog Number	Throat Depth in. (mm)	Length in. (mm)	Net Wt. oz. (g)
SL2	1/4 to 5/8 (6.35 to 15.88)	8 (203)	16 (454)

Not Recommended for Heavy Sheet Metal.



C4

Downspout Crimpers

5 Blade Crimper

Produces a double crimp that downsizes without deforming down-spout; walls stay square for a tight fitting, leakproof connection. Tool also features rust resistant plating. Non-slip vinyl grips with hand stops provide added comfort and resistance to elements.

Catalog Number	Throat Depth in. (mm)	Length in. (mm)	Net Wt. oz. (g)
C4	1-1/4 (31.75)	9 (229)	16 (454)

Replacement Spring for Hand Tools

5018 Fits SL2 and C4 (see page 10 for full list.)

CAPACITIES

Material:	Aluminum	Copper	Stainless Steel	Galvanized Sheet Metal
Inches (mm)	.035 (0.89)	.023 (0.58)	.021 (0.53)	.023 (0.58)

TOOL SPECIFICATIONS

Blades	Variable Leverage Ratio High/Low Throughout Stroke
Carbon Steel	7.1 to 1.0 - 9.8 to 1.0

Single Crimper

Light duty tool without grips. Makes a single crimp for downsizing aluminum downspouts.

Catalog Number	Throat Depth in. (mm)	Length in. (mm)	Net Wt. oz. (g)
SC2	1-1/8 (28.58)	8 (203)	8 (227)





EXPANDED LINE

Gutter Outlet Punches

All Malco Gutter Outlet Punch and Dies make clean, accurate hole cuts in aluminum gutter (.032 max). Ample throat clearance allows these lightweight outlet punches to work over the front edge of gutter to quickly line up cuts. Fastener holes are provided in the tool frame base for optional bench mount application. An easy ratcheting mechanism and angled punch-blade provide smooth cutting action. High carbon steel blades on punches assure long service life and are also easily replaceable. Heat treated components and weather resistant finishes provide added tool strength and durability.

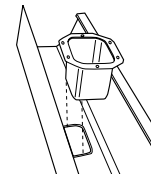

GOP23LUK
GOP23UK
GOP34UK

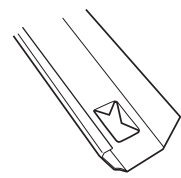

GOP23XUK

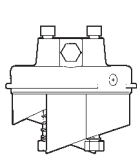

GOP23UK
GOP23LUK

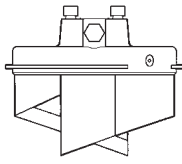

GOP34UK

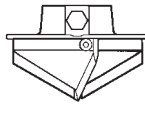

GOP23XUK

TOOL FRAME

Order punch and die assembly separately

Catalog Number	Description	Frame Dim.'s in. (mm)	Net Wt. lbs. (kg)
GOT	Tool Frame	19x10 (483x254)	6.7 (3.04)
GOTRC	Replacement Chocks		



Partial list of larger nominal 2" x 3" drops compatible with the GOP23LUK includes:

AMERIMAX GUTTER SUPPLIERS PETIT	BERGER BROTHERS LYNCH ALUMINUM RAYTEC	BUCHNER MFG. METALTECH US ALUMINUM	CLENDENON MATTEO ALUMINUM
---------------------------------------	---	--	------------------------------

Malco Gutter Drops

True 2" x 3" and 3" x 4" dimensions are compatible with Malco's standard GOP23UK and GOP34UK punches.

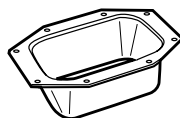

GD23
2" x 3" drop works with Malco GOP23UK outlet punch

GD34
3" x 4" drop works with Malco GOP34UK outlet punch



Catalog Number	Description
GD23	2" x 3" (51 x 75 mm) Aluminum Gutter Drop
GD34	3" x 4" (76 x 102mm) Aluminum Gutter Drop

PUNCH AND DIE ASSEMBLIES

Catalog Number	Description	Net Wt. lbs. (kg)
2.2" x 3.2" (56 x 81 mm) OVERSIZE Rectangular Hole (See list of oversize drops at left.)		
GOP23LUK	Punch and Die Assy - Upgrade Kit	2.2 (0.98)
GOP23LRB	Replacement Blade	1.3 (0.58)
2" x 3" (51 x 76 mm) Standard Rectangular Hole (Works with Malco GD23 and other true 2" x 3" drops.)		
GOP23UK	Punch and Die Assy - Upgrade Kit	2.2 (0.98)
GOPRB	Replacement Blade	1.3 (0.58)
3" x 4" (76 x 102 mm) Standard Rectangular Hole (Works with Malco GD34 and other true 3" x 4" drops.)		
GOP34UK	Punch and Die Assy - Upgrade Kit	2.5 (1.13)
GOP34RB	Replacement Blade	1.8 (0.83)
2" x 3" (51 x 76 mm) X-Style (No drop required. Fasten downspout securely to ears created by X.)		
GOP23XUK	Punch and Die Assy - Upgrade Kit	1.9 (0.87)
GOP23XRB	Replacement Blade	0.16 (0.07)

Punch Lock Stud Crimper

Secures any width Stud and Runner without screws or other fasteners.

PL1

Unique Punch and die are easily replaceable

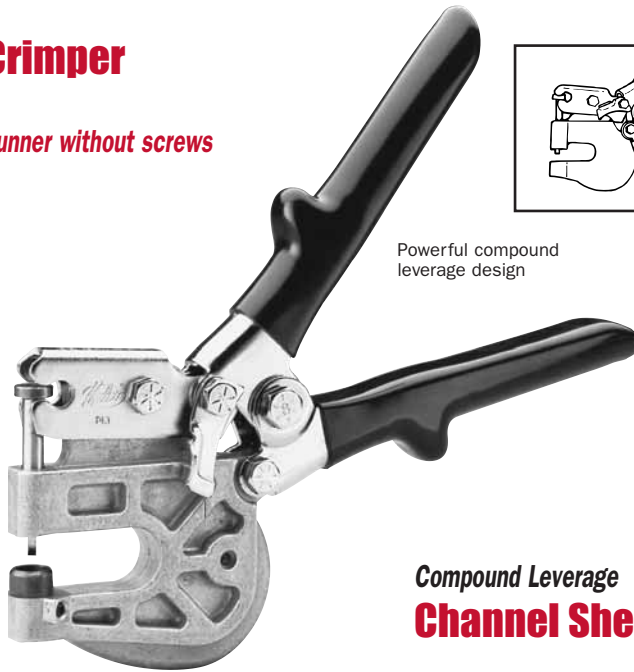

Powerful compound leverage design

Maximum capacity 22 gauge stud and runner.

Black vinyl cushion grips with handle stops.

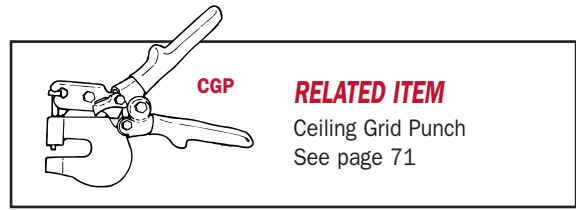

CGP

RELATED ITEM

Ceiling Grid Punch
See page 71

Compound Leverage Channel Shear



SRC24A

Compound leverage increases mechanical advantage nearly 7 to 1. Simply squeeze handles together with one hand while holding stud in place. A unique punch and die shape creates a rectangular crimp, bending over thicknesses of channel and stud at the same time to form a sturdy bond. Crimp is always the proper strength and resists stress from any angle. Spring return handles snap the punch back in a ready position to go on to the next stud or fastening point. Lightweight and compact size allows the user to work overhead or in tight quarters with ease. Tool fits inside the smallest stud and runner. Punch and dies are constructed from high quality tool steel and are easily replaceable. Body of tool consists of an aluminum die cast 'C' frame and rust resistant, nickel plated steel handles and parts. Tool also features non-slip vinyl grips with hand stops for added comfort and resistance to elements.

Compound leverage shear cuts through 20 gauge metal studs and runner faster, easier and more economically than any other tool on the market. Shear completes cut in one easy stroke without deforming metal channel. Die assembly assures that cutting action is clean and precise. Hollow ground hardened steel blade can be resharpened or replaced. A 36" long handle provides additional leverage making cutting with this shear almost effortless. Lightweight and portable enough to be where you want it, when you want it. Model SRC24A cuts 3 basic channel sizes (1-5/8, 2-1/2 & 3-5/8" stud and accommodating runners). Shear features rugged all steel and bolt construction. Handle has red vinyl comfortable grips.

Catalog Number	Description	Throat Depth in. (mm)	Capacity (Sheet Metal)	Net Wt. oz. (g)
PL1	Punch Lock/ Stud Crimper	1-1/2 (38.10)	Max. (2) layers 22 gauge.	16 (454)

Replacement Parts

PLD1	Replacement Punch and Die
------	---------------------------

CAPACITIES

Material:	Aluminum	Copper	Stainless Steel	Galvanized Sheet Metal
Inches (mm)	n/a	n/a	n/a	.035 (0.89) up to 2 layers

TOOL SPECIFICATIONS

Punch / Frame	Variable Leverage Ratio High/Low Throughout Stroke
Tool Steel Punch w/Cast Aluminum Frame	Shear Action (Punch)

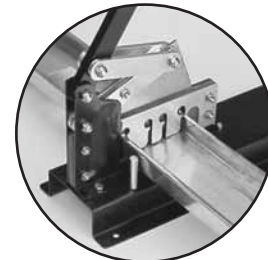
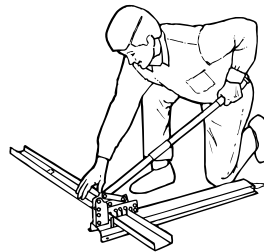

Catalog Number	Capacity	Cuts both Stud & Runner Sizes in. (mm)	Height in. (mm)	Length in. (mm)	Net Wt. lbs. (kg)
SRC24A	20 gauge	1-5/8, 2-1/2 & 3-5/8 (41, 64 & 92)	8 (203)	36 (914)	23 (10.43)

Replacement Blade

Catalog Number	Description
10627	One replacement blade and two spacers. Field replacement.



Professional Caulking Guns

Square Piston Design



CG20

Puncture wire folds inside handle.



CG25

Puncture wire.

Heavy duty professional models with thumb-activated pressure release. Designed for use with spouted cartridge. Powerful ratcheting action minimizes worker fatigue or need to warm up caulk. User can regulate stroke to fit hand. Square piston rod may be rotated to expose new gripping surface and increase service life of tool. Handy puncture wire folds inside handle.

Catalog Number	Application	Cartridge Capacity	Carriage Dia. in. (mm)	Length in. (mm)	Net Wt. oz. (g)
CG20	Spouted Cartridge	1/10 gal.	2 (51)	8-1/2 (216)	28 (794)
CG25	Spouted Cartridge	1qt.	2-5/8 (67)	12 (305)	44 (1247)

Round Piston Design Caulking Gun

CG30



Puncture wire folds inside handle.

Accommodates 1/10 gallon spouted cartridge. Puncture wire folds inside handle. Smooth round action piston. Easy to activate pressure release. Metallic finish.

Catalog Number	Application	Cartridge Capacity	Carriage Dia. in. (mm)	Length in. (mm)	Net Wt. oz. (g)
CG30	Spouted Cartridge	1/10 gal.	2 (51)	9 (229)	21 (595)

Utility Caulking Guns

CG10



CG15



Catalog Number	Application	Cartridge Capacity	Carriage Dia. in. (mm)	Length in. (mm)	Net Wt. oz. (g)
CG10	Spouted Cartridge	1/10 gal.	2 (51)	8-1/2 (216)	17 (482)
CG15	Spouted Cartridge	1qt.	2-5/8 (67)	12 (305)	33 (936)

SNIPS: For Metal & Vinyl



MAX[®] 2000

**Nothing outcuts,
outmaneuvers
or outlasts MAX!**

ERGONOMIC GRIP
maximizes power
stroke of hand

CLASSIC GRIP
with the fit and
feel of tradition

Tips of jaws ground to point
allows access in tight quarters.

Multi-operational
latch is
accessible from
right, left or top.

Extra long life
compression
spring.

Color-coded TPE
(thermoplastic
elastomer)
upper grip.



Color coded
PVC
(Polyvinyl
chloride)
upper grip.



Riveted handle
will not loosen.

Nylon
lower
grip

Metal
Latch

Piano wire torsion
handle spring.

PVC
lower
grip.



M2001
Ergonomic

M2002
Ergonomic

M2003
Ergonomic

MAXCG1
CLASSIC
GRIP

MAXCG2
CLASSIC GRIP

MAXCG3
CLASSIC GRIP



Catalog Number	Length of Cut in. (mm)	Grip	Length in. (mm)	Net Wt. oz. (g)
M2001 / MAXCG1	1.375 (34.93)	red	10.75 (273)	13.80 (391)
M2002 / MAXCG2	1.375 (34.93)	green	10.75 (273)	13.80 (391)
M2003 / MAXCG3	1.687 (42.86)	yellow	10.75 (273)	13.80 (391)



Max2000 Bulldog Aviation Snips

M2005
Ergonomic

MAXCG5
CLASSIC
GRIP



Catalog Number	Length of Cut in. (mm)	Grip	Length in. (mm)	Net Wt. oz. (g)
M2005 / MAXCG5	1.062 (26.95)	red	10.00 (254)	12.70 (360)



Max2000 Offset Aviation Snips

M2006
Ergonomic

M2007
Ergonomic

MAXCG6
CLASSIC
GRIP

MAXCG7
CLASSIC
GRIP



Catalog Number	Length of Cut in. (mm)	Grip	Length in. (mm)	Net Wt. oz. (g)
M2006 / MAXCG6	1.25 (31.75)	red	10.75 (273)	15.50 (439)
M2007 / MAXCG7	1.25 (26.95)	green	10.75 (273)	15.50 (439)

Replacement Spring

M2000S Fits all Max2000 Snips

CAPACITIES • ALL MAX2000 SNIPS

Material	Aluminum	Copper	Stainless Steel	Galvanized Sheet Metal
Inches (mm)	.062 (1.57)	.054 (91.46)	.038 (0.97)	.054 (1.46)
TOOL SPECIFICATIONS				
Jaws		Variable Leverage Ratio High/Low Throughout Stroke		
Fine Blanked Alloy Steel		3.7 to 1.0 - 5.2 to 1.0		



Forged Steel AVIATION SNIPS



Catalog Number	Cutting Application	Length of cut in. (mm)	Grips	Length in. (mm)	Net Wt. oz. (g)
AV1	Cuts left	1.38 (34.93)	red	9.63 (245)	13.70 (388)
AV2	Cuts right	1.38 (34.93)	green	9.63 (245)	13.70 (388)
AV3	Cuts straight, left and right	1.50 (38.10)	yellow	9.88 (251)	13.70 (388)



AV's Offset Aviation Snips



AV6	Cuts sharp left angles, straight lines and tight diameter circles.	1.25 (31.75)	red	9.63 (245)	14.50 (411)
AV7	Cuts sharp right angles, straight lines and tight diameter circles.	1.25 (31.75)	green	9.63 (245)	14.50 (411)

Offset DOUBLE CUT SNIP

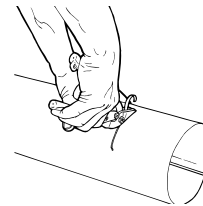

Double cut design is ideal for cutting metal pipe or duct. Double cut design removes a curled strip of metal from path with virtually no surface distortion. Double cut also features adjustable taper ground outer blade. Offset handle design aids maneuverability and also protects user's hands.

Catalog Number	Cutting Application	Length of cut in. (mm)	Grips	Length in. (mm)	Net Wt. oz. (g)
4R	Straight inside cuts	0.69 (17.46)	yellow	8.50 (216)	14.00 (397)

SNIPS: For Metal & Vinyl



**AndyTM
SNIP**

Lightweight with strength of steel!

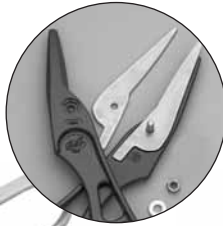

Pressure-fit inset blades make field replacement easy!

Larger ungripped handle loops accommodate small, large or gloved hands.



Comfort Gripped Option. For cushiony comfort, fit and control in cold, wet or heat.



Slim nose makes cuts in J-channel, and other tight material shapes.

Full 3-inch cut. Extended blade tips reach into corners.



Andy 12-Inch Pattern

Straight shearing, mild curve cuts, and multiple layers of material.

Catalog Number	Length of cut in. (mm)	Tool Length in. (mm)	Net Wt. oz. (g)	Repl. Blade
M12N	3.00 (76)	12.00 (304)	15.50 (439)	M12NRB
M12NG Grip	3.00 (76)	12.00 (304)	20.10 (570)	M12NRB



Andy 12-Inch Combination

L or R circles to 6" (152.40 mm) diameter and straight cuts.

Catalog Number	Length of cut in. (mm)	Tool Length in. (mm)	Net Wt. oz. (g)	Repl. Blade
MC12N	3.00 (76)	12.00 (304)	15.50 (439)	MC12NRB
MC12NG Grip	3.00 (76)	12.00 (304)	20.10 (570)	MC12NRB



Big 14-Inch frame and handle loops with 3.25 inch cutting length.

M14N



Blade tips reach into corners.

MC14N

Sleek head design for greater maneuverability.



Pressure-fit inset blades make field replacement easy!



Andy 14-Inch Pattern

Straight shearing, mild curve cuts, and multiple layers of material.

Catalog Number	Length of Cut in. (mm)	Tool Length in. (mm)	Net Wt. oz. (g)	Repl. Blades
M14N	3.25 (82.55)	14.25 (362)	19.50 (553)	M14NRB

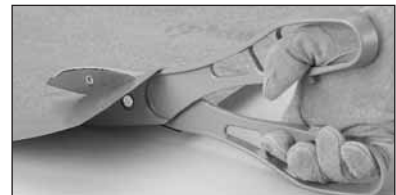

Andy 14-Inch Combination

L or R circles to 6" (152.40 mm) diameter and straight cuts.

Catalog Number	Length of Cut in. (mm)	Tool Length in. (mm)	Net Wt. oz. (g)	Repl. Blades
MC14N	3.25 (82.55)	14.25 (362)	19.50 (553)	MC14NRB





Original 12-Inch Styling



M12A

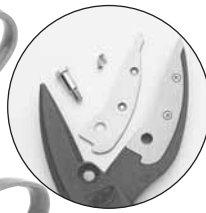

Blades are easily replaceable with the use of a common wrench and #2 Phillips driver.



MC12A

Familiar round design.



The snug fit and feel of the Original.



Andy Classic 12-Inch Pattern

Straight shearing, mild curve cuts, and multiple layers of material.

Catalog Number	Length of Cut in. (mm)	Tool Length in. (mm)	Net Wt. oz. (g)	Repl. Blades
M12A	3.00 (76.20)	12.00 (305)	16.70 (473)	M12ARB

For original model M12, use replacement blades M12RB.

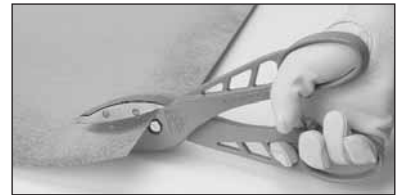

Andy Classic 12-Inch Combination

L or R circles to 6" (152.40 mm) diameter and straight cuts.

Catalog Number	Length of Cut in. (mm)	Tool Length in. (mm)	Net Wt. oz. (g)	Repl. Blades
MC12A	3.00 (76.20)	12.00 (305)	16.70 (473)	MC12ARB

For original model MC12, use replacement blades MC12RB.



Original 14-Inch Styling



M14A



Blades are easily replaceable with the use of a common wrench and #2 Phillips driver.



MC14A



Andy Classic 14-Inch Pattern

Straight shearing, mild curve cuts, and multiple layers of material.

Catalog Number	Length of Cut in. (mm)	Tool Length in. (mm)	Net Wt. oz. (g)	Repl. Blades
M14A	3.25 (82.55)	14.00 (356)	22.30 (632)	M14ARB

For original model M14, use replacement blades M14RB.



Andy Classic 14-Inch Combination

L or R circles and straight cuts.

Catalog Number	Length of Cut in. (mm)	Tool Length in. (mm)	Net Wt. oz. (g)	Repl. Blades
MC14A	3.25 (82.55)	14.00 (356)	22.30 (632)	MC14ARB

For original model MC14, use replacement blades MC14RB.



CAPACITIES • ALL ANDY SNIPS

Material:	Vinyl	Aluminum	Copper Steel	Stainless Sheet Metal	Galvanized Sheet Metal 24 Gauge
Inches (mm)	.055 (1.40)	.035 (0.89)	.023 (0.58)	.021 (0.53)	.023 (0.58)

TOOL SPECIFICATIONS

Inset Blades	Variable Leverage Ratio High/Low Throughout Stroke
High Carbon Steel	Shear Action

SNIPS: For Metal & Vinyl



**Ultra Lightweight
Combination Snip**

Fiberglass reinforced, polymer frame with spring return handles. Makes left, right or straight cuts in sheet steel, aluminum, vinyl and other thin materials. Cuts circles down to 6 inches (152 mm) diameter. Inset steel blades offer long service life. Routine light oiling of blades is recommended to resist corrosion. Blades are also easily replaceable.



10 and 12-inch Navi-Gator

Catalog Number	Length of Cut in. (mm)	Tool Length in. (mm)	Net Wt. oz. (g)
M2010	2.00 (50.80)	10.00 (254)	8.40 (238)
M2012	3.00 (76.20)	12.00 (305)	11.80 (335)

Replacement Blade **M2010RB** / **MB2012RB**, Spring **M2021S**



14-inch Navi-Gator

Catalog Number	Length of Cut in. (mm)	Tool Length in. (mm)	Net Wt. oz. (g)
M2014	3.50 (88.90)	14.00 (356)	15.30 (434)

Replacement Blade **M2014RB**, Spring **M2024S**

M2010

Compact 10 inch (254 mm) snip with big 2 inch (50.80 mm) blades. A narrow exposed nose easily cuts into tight corners and operates in clearances as small as 1/2 inch (13 mm).

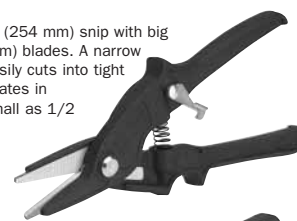

M2012

12 inches (305 mm) long with 3 inch (76.20 mm) blades. Exposed tips of blades allow easy maneuvering in tight corners.

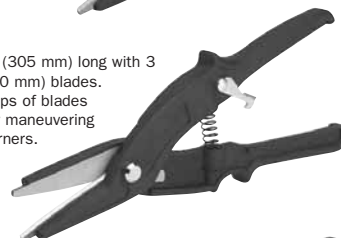

M2014

14 inches (356 mm) long with fast shearing 3-1/2 inch (88.90 mm) blades.



FORGED STEEL SNIPS



Regular Pattern Snip

For straight cutting and wide curves.

Catalog Number	Length of Cut in. (mm)	Tool Length in. (mm)	Net Wt. oz. (g)
M9	3.00 (76.20)	12.50 (318)	26.70 (757)

M9



Bulldog Pattern Snip

Big, powerful snip for straight cuts and notches.

Catalog Number	Length of Cut in. (mm)	Tool Length in. (mm)	Net Wt. oz. (g)
M15	2.50 (63.50)	16.50 (419)	59.20 (1678)

M15



Vinyl Combination Snip (Not For Metal Cutting)

Cuts through lock-seam edge of toughest vinyl siding material.

Catalog Number	Length of Cut in. (mm)	Tool Length in. (mm)	Net Wt. oz. (g)
VS12	3 (76.20)	12.50 (318)	26.60 (757)

VS12



MD7



MD10



MD12



Circular "Duckbill" Snips

Catalog Number	Length of Cut in. (mm)	Tool Length in. (mm)	Net Wt. oz. (g)
MD7	1.75 (44.45)	7.00 (178)	9.20 (261)
MD10	2.50 (63.50)	10.00 (254)	13.00 (369)
MD12	3.00 (76.20)	12.50 (318)	26.50 (751)

Maneuvers and cuts easily to very tip of blade. Cuts sheet metal, aluminum and steel siding, plastics and other thin materials without tearing or catching.

TurboShear™



For best results, be sure to keep the *TURBOSHEAR* blades level with cutting plane, this offset design also keeps hands away from work surface. **NOTE: Requires two hands to operate.** Metal must be pre-set in place or held by an assistant.



The *TURBOSHEAR* cuts straight and to the left and is capable of navigating tight curved patterns and square cuts. Blind cuts require only a 1/2" starting hole.



The *TURBOSHEAR* makes short work of long rip cuts in metal roofing or building panels. And cutting steel mesh is a breeze with the amazing *TURBOSHEAR*.



Make your drill a **POWER SHEAR-INSTANTLY!**

The time-saving *TURBOSHEAR* Model No. TS1 inserts directly into the chuck of a standard 1200 rpm A/C or cordless drill. It's that easy to convert your power drill to a power shear! This rugged but inexpensive accessory cuts straight and to the left and is capable of navigating tight curved patterns and squares in heavy 20-gauge galvanized steel. Blind cuts require only a 1/2" starting hole. Cutting applications include both ferrous and non-ferrous sheet metals, metal roofing/building panels, vinyl, steel mesh, ductwork, even the thick metal of furnace jackets, equipment enclosures or automotive body panels. An offset design keeps both hands away from work surface. Long-wearing hardened jaws are also replaceable.

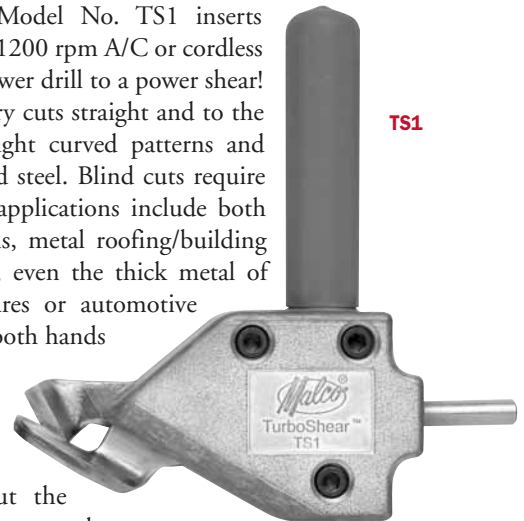

TS1

For premium performance without the premium price of a dedicated power shear, *TURBOSHEAR* is an easy addition to every tool box.



The camshaft of the *TURBOSHEAR* inserts directly into the 3/8" chuck of a standard 1200 rpm A/C or cordless drill.

SEE ADDENDUM PAGES 86-87.

- Drill Clamp option for TS1 allows one-hand operation.
- Big 18-Gauge Capacity TurboShearHD features heavy-duty gearing and larger, wider-opening jaws. A drill clamp comes standard.

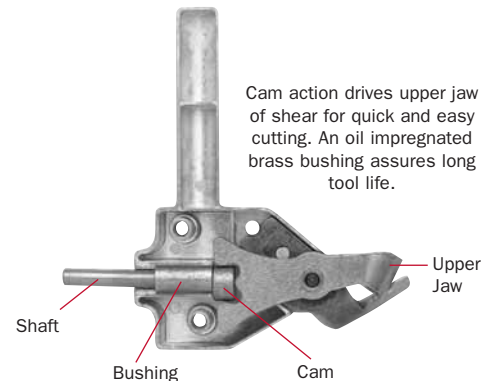

Cam action drives upper jaw of shear for quick and easy cutting. An oil impregnated brass bushing assures long tool life.

Catalog Number	Bar Code Number	Description	Net Wt. oz. (kg)	Capacity in Galv. Steel gauge (mm)	Pkg. Qty.
TS1	53020	TurboShear	26 (0.73)	20 (1.02)	1

Replacement Blades

TS1RB	53034	TurboShear Replacement Blades			1
-------	-------	-------------------------------	--	--	---

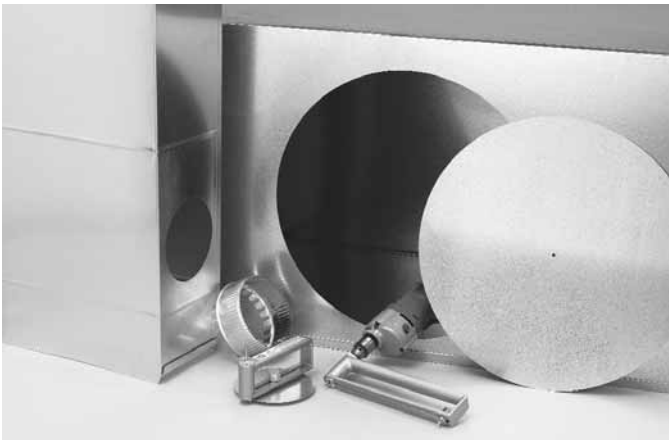

Hole Cutters



HC1



HC2

HC2 • Large Diameter Hole Cutter

The No. HC2 Hole Cutter adjusts for making 2 to 20 inch holes in galvanized sheet metal. It will install into the chuck of a standard electric drill as small as 1/4" and uses the same No. CB mill type Cutting Bit and other replacement parts as the more compact 12 inch maximum diameter HC1. Both Malco Hole Cutters store easily in a tool box and both the HC2 and HC1 feature a lightweight aluminum frame and high speed bearings at top and bottom of drill shaft to assure perfect cutting balance and long cutting life.

HC1 • The Original Malco Hole Cutter

Adjusts for cutting 2 to 12 inch holes in galvanized sheet metal. Lightweight aluminum frame.

Replacement Parts for HC1 and HC2

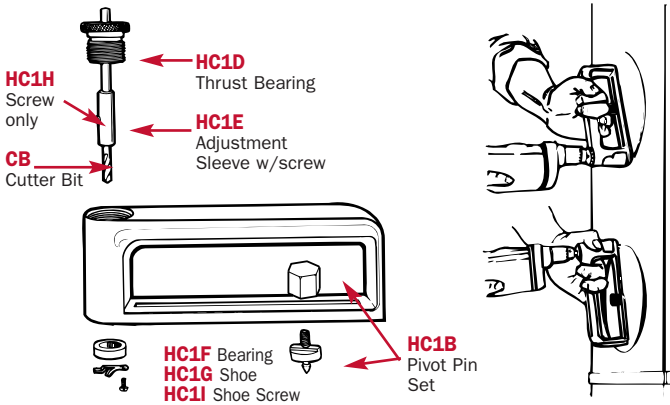

Catalog Number	Hole Dia. in. (mm)	Capacity	Net Wt. oz. (g)
HC1	2-12 (51-305)	20 ga.	16 (454)
HC2	2-20 (51-508)	20 ga.	22 (624)

NOTE: Cutting bit wears only in the dimension of the thickness of material cut. Adjusting bit up or down slightly will expose a new cutting edge and thus increase life of bit.

Replacement Cutter Bit

Catalog Number	Description
CB	Mill type cutting bit for HC1 & HC2

CAPACITIES

Material:	Aluminum	Copper	Stainless Steel	Galvanized Sheet Metal
Inches (mm)	.054 (1.46)	.042 (1.07)	.035 (0.89)	.042 (1.07)

TOOL SPECIFICATIONS

Cutting Bit	Variable Leverage Ratio
High Speed Steel	High/Low Throughout Stroke
* Recommended RPM 1350	n/a

Angle Drive Accessory



HCAD
Fits 1/4", 3/8" electric drills.
Comes with own chuck

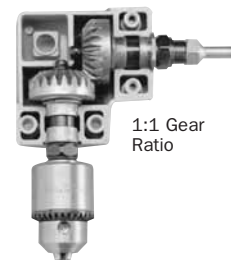

1:1 Gear Ratio

Works well with HC1 and HC2 Hole Cutters. May be used to help cut take-off holes in sheet metal ductwork suspended below floor joists or for take-offs from the side of large trunk lines where reaching up and cutting at 90° is desirable

Catalog Number	Description	Net Wt. oz. (g)
HCAD	Angle Drive Accessory	20 (567)





Hand Seamers with Die-Cast Zinc Jaws

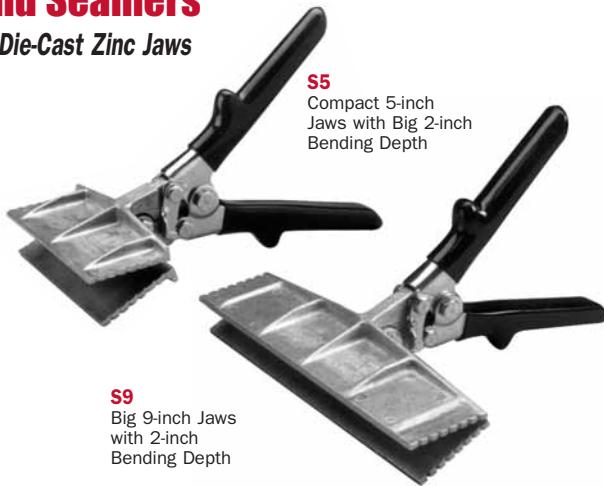

S5
Compact 5-inch
Jaws with Big 2-inch
Bending Depth

S9
Big 9-inch Jaws
with 2-inch
Bending Depth

Ideal for making clean and accurate angle bends for aluminum roof flashing, coil stock or fascia. Jaws feature depth graduations in 1/4" increments to a maximum 2" bending depth. Lightweight die cast zinc jaws with compound handle leverage offer comfort and ease of use on-the-job, even when working from heights. Durable construction offers long, dependable service life under normal use. Tool also features rust resistant nickel plating. Non-slip vinyl grips with hand stops provide added comfort and resistance to elements. **Malco S5 and S9 Seamers are not warranted for use as a striking tool or for use on ferrous sheet metal.**

Catalog Number	Jaw Depth in. (mm)	Jaw Width in. (mm)	Overall Length in. (mm)	Net Wt. oz. (g)
S5	2 (50.80)	5 (127)	9 (229)	22 (624)
S9	2 (50.80)	9 (229)	9 (229)	28 (794)

CAPACITIES

Material:	Aluminum	Copper	Stainless Steel	Galvanized Sheet Metal
Inches (mm)	.029 (0.74)	n/a	n/a	n/a

TOOL SPECIFICATIONS

Jaws	Variable Leverage Ratio High/Low Throughout Stroke
Die Cast Zinc	4.7 to 1.0 - 7.1 to 1.0

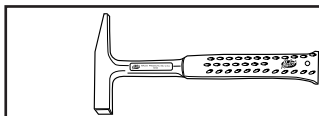

RELATED ITEMS

Sheet Metal Hammers
See Page 58

Hand Seamers with Forged Steel Jaws



S2
3-inch Jaws

S3
3-inch Jaws
with Offset Handles

S6
6-inch Jaws

Precise vee-notched depth graduations on jaws are in 1/4" increments. Jaws are drop forged, high impact steel. Hardened steel handles resist abuse. Powerful compound leverage design. Tool also features rust resistant nickel plating. Non-slip vinyl grips with hand stops provide added comfort and resistance to elements.

3" Hand Seamer

Catalog Number	Jaw Depth in. (mm)	Jaw Width in. (mm)	Overall Length in. (mm)	Net Wt. oz. (g)
S2	1-1/4 (31.75)	3-1/4 (83)	8 (203)	24 (680)

3" Offset Hand Seamer

Works overhead or in confined areas.

S3	1-1/4 (31.75)	3-1/4 (83)	8 (203)	24 (680)
-----------	---------------	------------	---------	----------

6" Hand Seamer

Wide 6" jaws produce uniform, accurate bends in sheet steel and non-ferrous metals with greater control and efficiency. Wider jaws also minimize buckling and bowing of metal. Fewer strokes are required to bend and straighten angles. Designed for all the metal trades, including HVACR installation, roofing and siding applications and commercial building and remodeling.

S6	1-1/4 (31.75)	6 (152)	8 (203)	30 (851)
-----------	---------------	---------	---------	----------

CAPACITIES

Material:	Aluminum	Copper	Stainless Steel	Galvanized Sheet Metal
Inches (mm)	.035 (0.89)	.023 (0.58)	.021 (0.53)	.023 (0.58)

TOOL SPECIFICATIONS

Jaws	Variable Leverage Ratio High/Low Throughout Stroke
High Carbon Steel Forgings	4.7 to 1.0 - 7.1 to 1.0

Replacement Spring for Hand Tools

5018	Fits C4, C5, FCN, JCC, JCC50, JCC75, N1, N2, NHP1, S2, S3, S5, S6, S9, SC3, SL1, SL2 AND SL8
-------------	--

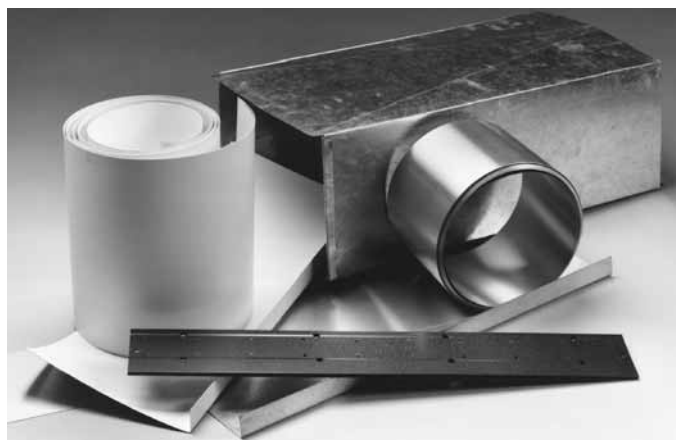

Adjustable Folding Tool



9A

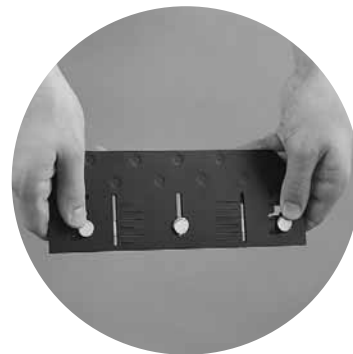

Quickly adjusts from 1/4" to 1-1/2" folding depths.

Folding Tools

Folding seams are formed from two steel halves, permanently joined together. Handy sight holes assure proper depth alignment.

3/8 in. and 1 in. folding depths

24F

18F

12F

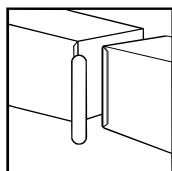
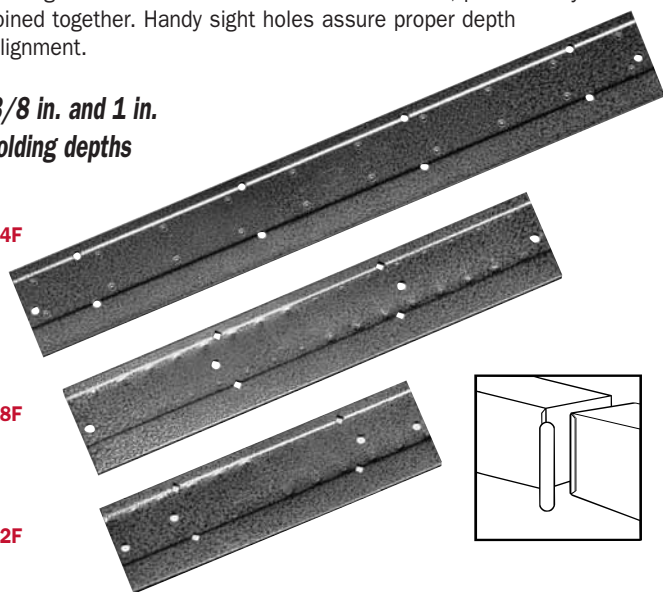

No. 12F (12-in. long tool) is ideal for HVAC applications such as 3/8" folds for drive cleats and big 1 in. deep folds for joist panning, plenums, register boots, trunk line end caps and more

Longer, No. 18F (18-in. tool) assures a uniform fold.

Extra long No. 24F (24-in. tool) may also be used as a mini brake by siding applicators.

Catalog Number	Folding Depths in. (mm)	Width in. (mm)	Net Wt. oz. (g)
12F	3/8 (9.53), 1 (25.40)	12 (305)	20 (425)
18F	3/8 (9.53), 1 (25.40)	18 (457)	31 (879)
24F	3/8 (9.53), 1 (25.40)	24 (610)	42 (1191)

3/8 in. and 1/2 in. folding depths

8

12

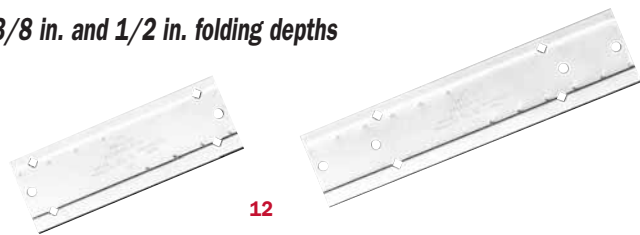

Catalog Number	Folding Depths in. (mm)	Width in. (mm)	Net Wt. oz. (g)
8	3/8 (9.53), 1/2 (12.70)	8 (203)	12 (340)
12	3/8 (9.53), 1/2 (12.70)	12 (305)	18 (510)

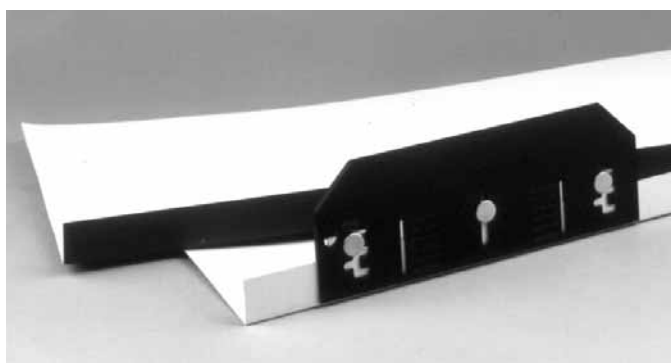

Folds trim coil and aluminum siding.

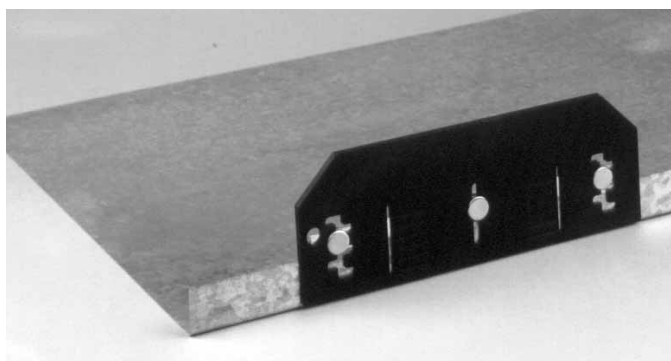

Folds sheet metal up to 26 gauge.

Malco's No. 9A Adjustable Folding Tool easily folds edges of aluminum siding, trim coil and lighter gauges of sheet metal (up to 26 gauge). The 9A quickly adjusts from 1/4" to 1-1/2" folding depths in 1/4" increments. The adjustment mechanism is completely hand operated; there are no loose parts or extra tools to contend with. A compact 3-1/4" x 9" size provides easy leverage for any folding depth.

The tool also features a handy hang hole for workbench applications, or stores easily in a tool box. Fully hardened steel plate construction and corrosion resistant black zinc coating assures long service life.

Catalog Number	Folding Depths Range in. (mm)	Width in. (mm)	Net Wt. oz. (g)
9A	1/4 to 1-1/2 (6.35 to 38.10)	9 (229)	18 (510)



PORTABLE

Mini Brake™

Ideal Job-Site Tool for HVAC and Roofing Contractors.

Makes bends to 135 degrees in galvanized sheet metal up to 22 gauge. A beefed-up 1/4-inch plate steel apron and 4-foot metal width capacity makes the Mini Brake ideal for fabricating plenums or large transitions at the job site.

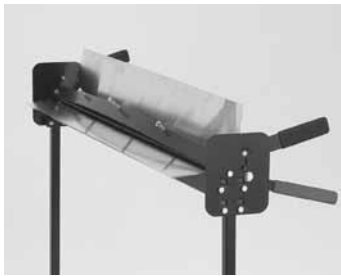

The Mini Brake also bends metal roofing components and roof flashing including copper and aluminum.



Compact size makes the Mini Brake suitable for use virtually anywhere on the job site. Extra wide feet offer stability even when operating on a truck tailgate.

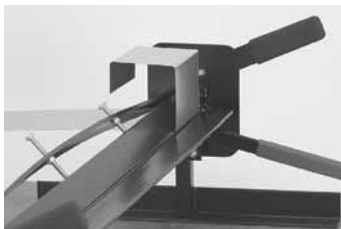

Accommodates sheet metal up to 4-feet wide in any length. There is no fixed throat depth to contend with.

Versatile bending range accommodates compact fabrications as small as a 4-inch square.

A 1/4-inch plate sheet apron and adjustable strengthening ribs on anvil assure uniform bends across width of material.

Common 5/16-inch, course-thread adjustment bolts on anvil are factory set and are also easily adjustable in the field as necessary.

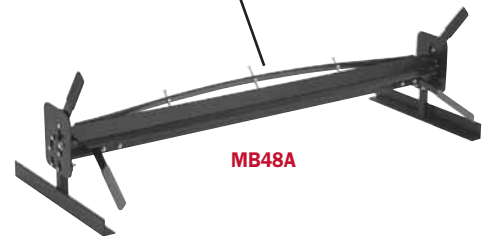
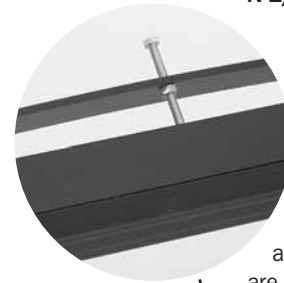

Dual-direction, cam-over style clamps keep anvil secure in any position. This safety conscious feature prevents anvil from free falling or creating a pinching hazard.

Catalog Number	Capacity Galvanized Gauge (mm)	O/A Width in. (m)	Net Wt. lbs. (kg)
MB48A	22 (0.86)	48 (1.22)	72.0 (32.66)

OPTIONAL LEG KIT

MBL	-	-	18 (8.17)
------------	---	---	-----------

MBL
Optional Leg Kit



LEGS ARE SOLD SEPARATELY AND ARE EASILY INSTALLED IN THE FIELD

Scratch Awls

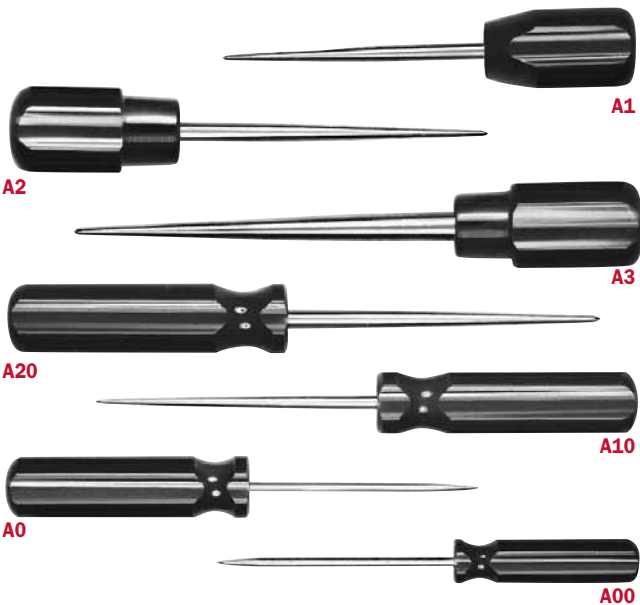
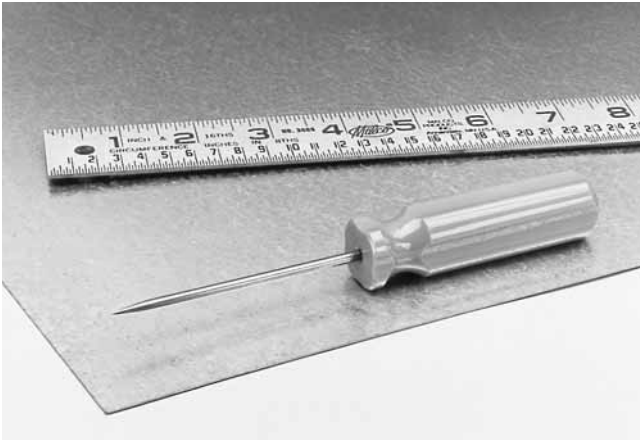

Use to scribe lines on metal, plastic and a variety of other materials. Pierce holes in wood, plastic, leather, - even light gauge metal. Blades are high carbon, alloy tool steel fully polished to resist rust. Blade tapers to a fine point and may be resharpened many times. Easy-to-spot orange handles are shock and shatter resistant. Shallow fluted handles with large end bearing surface provide a sure, comfortable grip. User has choice of large diameter or regular grip handles.

Catalog Number	Nominal Blade Diameter in. (mm)	Blade Length in. (mm)	O/A Length in. (mm)
Regular Grip Handle			
A00	1/8 (3)	3 (76)	5-1/2 (140)
A0	1/8 (3)	3 (76)	6-1/4 (159)
A10	3/16 (5)	3-3/4 (95)	7 (178)
A1	7/32 (6)	3-1/2 (89)	5-3/4 (146)
A20	1/4 (6)	4 (102)	7-3/4 (197)
A2	1/4 (6)	4 (102)	6-1/4 (159)
A3	3/8 (10)	5 (127)	7-1/2 (191)

POCKET SIZE

Sheet Metal Scribe



A40 Five teeth produce 10 scribing depths.

Compact scribe stores in pocket, pouch or tool box.

Use hang hole or magnet to keep handy on -the-job.



Scribe common place trim lines on galvanized sheet metal quickly and accurately. Ten pre-set scribing depths from 1/8" to 1". Each scribing depth size features a dual edged point to create clean, readable and accurate score lines parallel to the edge of the metal sheet. Corrosion resistant finish and etched-in dimensions are readable for life of tool. Packaged in a clear vinyl, reusable pouch for storage in pocket, pouch or tool box.

Catalog Number	Scribing Depths in. (mm)
A40	1/8", 3/16", 1/4", 5/16", 3/8", 1/2", 5/8", 3/4", 7/8", 1" (3, 5, 6, 8, 10, 13, 16, 19, 22, 25 mm)

Carbide Tipped Scriber

Always a sharp point.



A50

Solid carbide tip for scribing fine lines on hardened steel as well as glass, ceramics, plastics or sheet metal. Retractable tip is easily replaceable. Tool has handy pocket clip. Carbide tip assures long service.

Catalog Number	Description
A50	Carbide Tipped Scriber with retractable point.
A50R	Replacement Carbide Tip.



ADJUSTABLE Sheet Metal Scriber



A60



Measure, mark and scribe trim lines on sheet metal in one easy operation. Set desired trim depth on the 1/8" graduated scriber extension and tighten knob. The stop at the end of the scriber sleeve glides along edge of work as a 6x3/8" sheet metal screw point scribes a clean, hard line. Adjustable from 1/4" to 12-1/2" depths. Rotate the scriber extension and knob end to end for depths larger than 6-1/2". The use of a common sheet metal screw makes point replacement practical and economical. Pocket size tool is constructed of rust resistant nickel plated steel. Knob assembly with hardened steel bolt insert will not strip out.

Catalog Number	Minimum & Maximum Adjustments inches (mm)	Net Wt. oz. (g)
A60	Scribes 1/4" to 12-1/2" (6 to 318) depths.	10 (284)

Replacement Parts

12027	Replacement Knob
--------------	------------------

Trammel Points



Two sizes handle a variety of layout applications. The TR42 expands to a big 42" radius (84" diameter). The compact TR18 expands to 18" and stores in most tool boxes. All steel construction. Points are resharpenable and also replaceable. Telescoping arms are nickel plated to resist corrosion. Handle features a comfortable vinyl grip.

Catalog Number	Radius Min. in. (mm)	Radius Max. in. (mm)	O/A Storage Lgth in. (mm)	Net Wt. oz. (g)
TR18	7 (178)	18 (457)	12 (305)	4 (113)
TR42	12 (305)	42 (1067)	24 (610)	7 (199)

Replacement Parts

TRP	1 pair replacement points
------------	---------------------------

Dividers

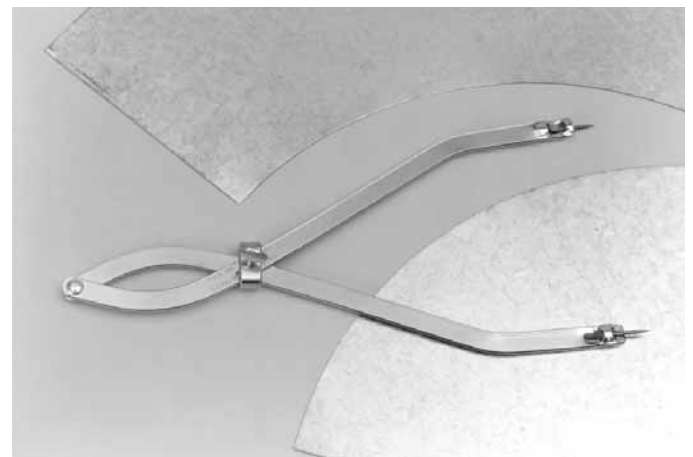

Accurate and fast adjusting. Two sizes for circles up to 32" and 42". Points are easily resharpen or replaced. Nickel plated steel body.

Catalog Number	Description in. (mm)	Length in. (mm)	Net Wt. oz. (g)
#18	Maximum diameter circle 32 (813)	11 (279)	7 (199)
#24	Maximum diameter circle 42 (1067)	13-1/2 (343)	9 (255)

Replacement Parts

RP2	Replacement points for #18 and #24
10018	Thumb Screw

Hand Notchers

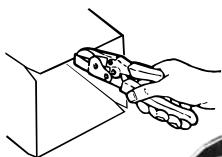

N1

Fast and easy cutting. Notcher makes a clean 30° "V" shaped cut in sheet metal. 13/16" maximum throat depth. Upper cutting jaw is drop forged high impact alloy steel. Hook design of cutting jaw facilitates notching corners or take-off tabs to desired depth without slipping. Rust resistant nickel plate and black oxide finishes. Tool also features vinyl grips with hand stops for added comfort and resistance to elements.

Catalog Number	Throat Depth in. (mm)	Cutting Angle	Length in. (mm)	Net Wt. oz. (g)
N1	13/16 (20.64)	30°	8 (203)	16 (454)

CAPACITIES

Material:	Aluminum	Copper	Stainless Steel	Galvanized Sheet Metal
Inches (mm)	.035 (0.89)	.023 (0.58)	.021 (0.53)	.023 (0.58)

TOOL SPECIFICATIONS

Jaws	Variable Leverage Ratio High/Low Throughout Stroke
Alloy Steel Forging w/Carbon Steel Shell	7.4 to 1.0 - 8.0 to 1.0

ONE-INCH NOTCHER



Provides more clearance for folding and fabricating metal ductwork

N2

The N2 Notcher punches a big 1 inch deep "V" notch in common 24 to 28 gauge galvanized sheet metal quickly and easily. A narrower handle opening provides additional user comfort while still allowing a full throat opening. Folding and fabricating metal ductwork is easier than ever with the full 1 inch clearance that the N2 single operation notcher provides.

Catalog Number	Description in. (mm)	Net Wt. oz. (g)
N2	1 (25.40) Notcher	17 (482)

Replacement Spring for Hand Tools

5018 Fits N1, N2, SL1 and SL2 (See page 27 for full list).

CAPACITIES

Material:	Aluminum	Copper	Stainless Steel	Galvanized Sheet Metal
Inches (mm)	.035 (0.89)	.023 (0.58)	.021 (0.53)	.023 (0.58)

TOOL SPECIFICATIONS

Jaws	Variable Leverage Ratio High/Low Throughout Stroke
Alloy Steel Forging w/Carbon Steel Shell	6.6 to 1.0 - 7.0 to 1.0

Snap Lock Punches



SL1

Join sheet metal, duct and pipe sections economically. No need for extra hardware. Punches raise a louvered shaped projection on metal edge for locking into rolled edge of sheet or piece to be joined. Metal pieces snap together and are fastened securely. Compound Handle Leverage for maximum ease of operation. Punch impression spaced 3/8" from edge of metal. Heavy forged cutting jaw. Rust resistant nickel plate and black oxide finishes. Tool also features vinyl grips with hand stops for added comfort and resistance to elements.

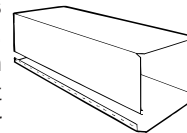

Catalog Number	Throat Depth in. (mm)	Length in. (mm)	Net Wt. oz. (g)
SL1	3/8 (9.53)	8 (203)	16 (454)

CAPACITIES

Material:	Aluminum	Copper	Stainless Steel	Galvanized Sheet Metal
Inches (mm)	.035 (0.89)	.023 (0.58)	.021 (0.53)	.023 (0.58)

TOOL SPECIFICATIONS

Jaws	Variable Leverage Ratio High/Low Throughout Stroke
Alloy Steel Forging w/Carbon Steel Shell	10.8 to 1.0 - 11.7 to 1.0

ADJUSTABLE SNAP LOCK PUNCH

Not recommended for heavy sheet metal

SL2



Slide adjustment for throat depth allows settings from 1/4" to 5/8" depth. Also used to crimp end caps on gutter. Nickel plate and black oxide finish. Green grips. Formed metal cutting jaws.

Catalog Number	Throat Depth in. (mm)	Length in. (mm)	Net Wt. oz. (g)
SL2	1/4 to 5/8 (6.35 to 15.88)	8 (203)	16 (454)



Pipe Crimpers

Easy Hand Motion and Greater Control:

A superior compound leverage mechanism offers maximum ease of operation. Comfortable opening, spring-actuated handles, and vinyl cushioned grips, give additional comfort and control.

Longer Lasting Performance

Wear resistant, hardened steel construction features heavy duty linkage between handles and jaws. Hardened steel also produces greater handle strength to resist abuse and collapsing. Nickel plating resists elements.

5-BLADE CRIMPER

Longer, shallower crimps produced with the C5 result in a tighter fitting, more self supporting, leak-proof connection in sheet metal pipe and duct.

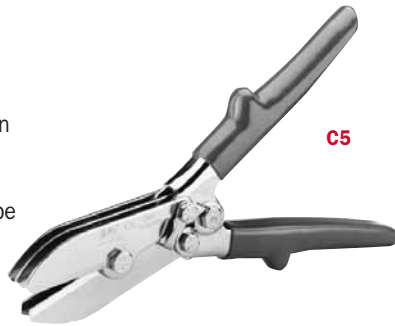

C5

Catalog Number	Throat Depth in. (mm)	Length in. (mm)	Net Wt. oz. (g)
C5	1-5/8 (41.28)	9-5/8 (244)	17 (482)

Replacement Spring for Hand Tools

5018 Fits C5 and SC3 (See page 27 for full list).

CAPACITIES

Material:	Aluminum	Copper	Stainless Steel	Galvanized Sheet Metal
Inches (mm)	.035 (0.89)	.023 (0.58)	.021 (0.53)	.023 (0.58)

TOOL SPECIFICATIONS

Blades	Variable Leverage Ratio High/Low Throughout Stroke
Carbon Steel	6.6 to 1.0 - 8.7 to 1.0

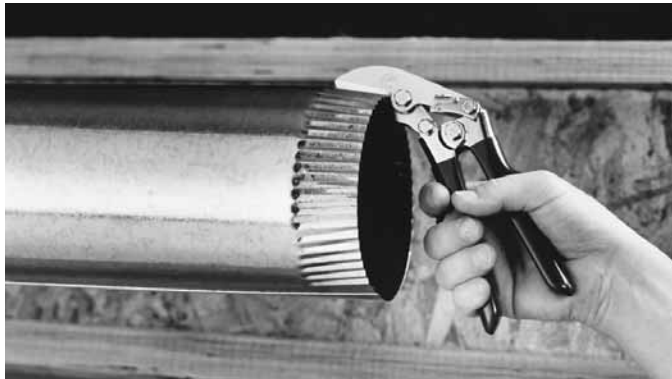

OFFSET CRIMPER

Ideal crimping tool wherever you encounter tight working quarters or working over-head. A unique blade design keeps handles offset and keeps hands off work obstacles such as floor joists and underlayments. The handle design also promotes correct gripping of tool resulting in less wrist fatigue.



C6

Catalog Number	Description	Throat Depth in. (mm)	Net Wt. oz. (g)
C6	Offset Pipe Crimper	1-5/8 (41.28)	16 (454)



3 BLADE CRIMPER

Ideal for crimping heavy 22 and 24 gauge sheet metal. Nickel plating and vinyl grips.

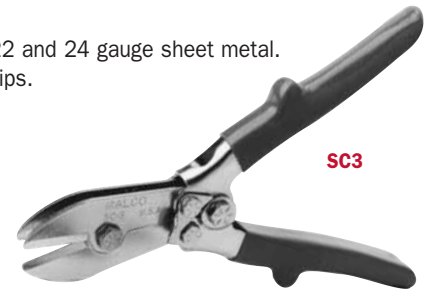
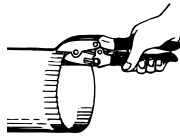

SC3

Catalog Number	Throat Depth in. (mm)	Length in. (mm)	Net Wt. oz. (g)
SC3	1-1/4 (31.75)	9 (229)	14 (397)

CAPACITIES

Material:	Aluminum	Copper	Stainless Steel	Galvanized Sheet Metal
Inches (mm)	n/a	.n/a	n/a	.035 (0.89)

TOOL SPECIFICATIONS

Blades	Variable Leverage Ratio High/Low Throughout Stroke
Carbon Steel	6.6 to 1.0 - 8.7 to 1.0

SINGLE CRIMPER

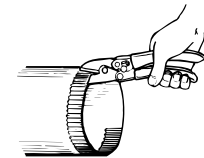

SC1

Fast, easy to use and lightweight. Handy lock makes tool pocket sized. Zinc plated steel. Red grips.

Catalog Number	Throat Depth in. (mm)	Length in. (mm)	Net Wt. oz. (g)
SC1	1-1/4(31.75)	8 (203)	8 (227)

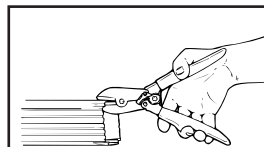

RELATED ITEMS

Downspout Crimpers
See Page 16

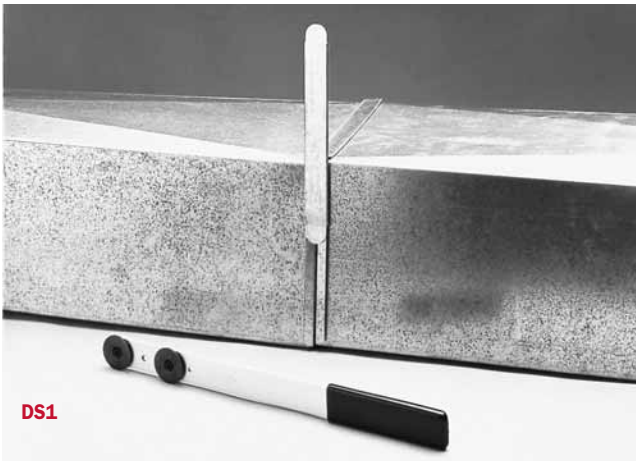

Locking Duct Stretcher

**Frees Hands
and Frees up Time.**

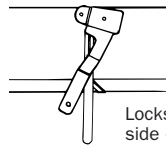

Locks on from either side of duct connection

Duct Stretchers

Use the Duct Stretcher to hold duct in place with one hand while slipping drive cleat in place with other hand. The low profile, straight body is designed to go anywhere, even in the tightest quarters. Additional spacing holes allow wheels to be adjusted to span greater distances. Rugged anodized aluminum body features large vinyl cushion grip and handy hang-up hole.

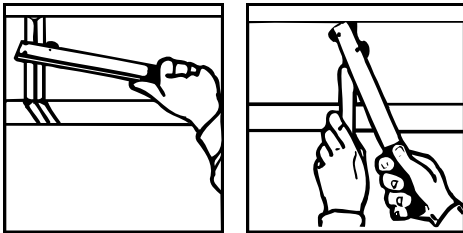

Catalog Number	Description	Length in. (mm)	Net Wt. oz. (g)
DS1	Duct Stretcher	16 (406)	12 (340)

Offset Duct Stretcher

Same features as DS1 plus offset handle to eliminate knuckle contact.



Catalog Number	Description	Length in. (mm)	Net Wt. oz. (g)
DS2	Offset Duct Stretcher	16 (406)	12 (340)

Replacement Parts for DS1, DS2, DS3

Catalog Number	Description
DS1C	Replacement wheels, nuts & screws (2 ea.)

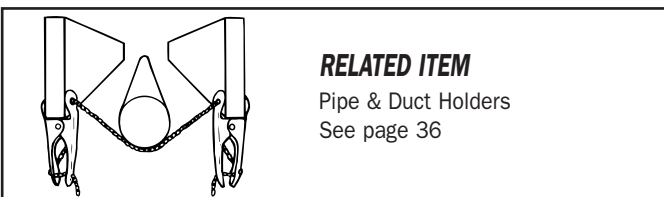

RELATED ITEM

Pipe & Duct Holders
See page 36

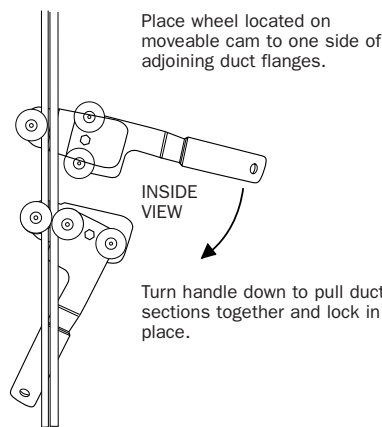

Locking duct stretcher pulls duct sections together and holds them in place while freeing both hands to align and install drive cleats.

The DS3 locks on from either side of duct connection. No need to adjust wheels! Simply place wheel located on moveable cam to one side of adjoining duct flanges. Turn handle downward to pull duct sections together and lock in place. Greater wheel clearance makes capturing the ends of duct sections, even misshapen flanges, easier than ever. The versatile shape of the DS3 frame also lets you hook and pull duct from above as the drive cleat is coaxed along the remainder of flanged track. The durable all steel frame extends beyond wheel edges, making it safe to push, hammer and bend drive cleats as necessary to complete installation. An offset handle design eliminates knuckle contact with work.

Catalog Number	Description	Length in. (mm)	Net Wt. oz. (g)
DS3	Locking Duct Stretcher	12 (305)	30 (851)



28 GAUGE Dampers

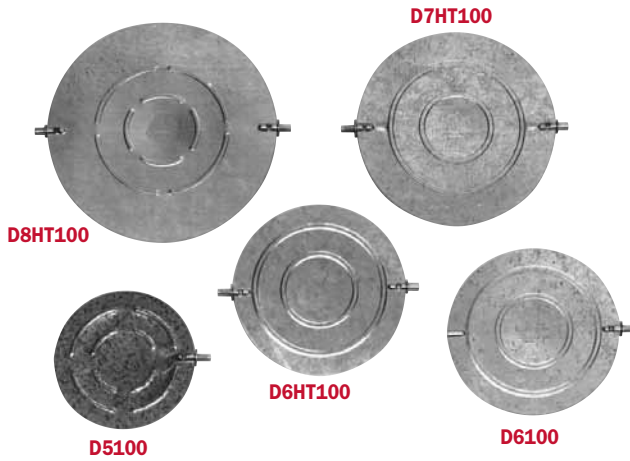

1/4" bearings allow bearing holes to be made in round duct with the use of a scratch awl. Squeeze pipe so that it is oval shaped. Insert damper into pre-punched bearing hole(s). Pipe will spring back to round when released. Secure with wing nut provided. Damper may be adjusted with screwdriver or optional damper handle. Available with or without handles.

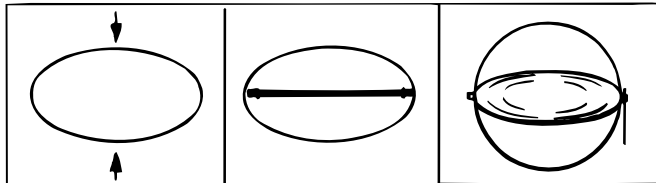
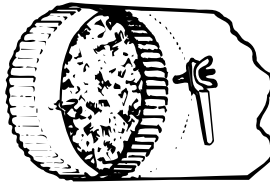

CAUTION: Malco Dampers are designed for forced air systems, they are not capable of being used in wood, coal, or other similar systems.

Standard Dampers Wing Nuts Included

28 Gauge (0.48 mm)

Catalog Number	Pipe Diameter in. (mm)	Bearing
D5100	5 (127)	single
D6100	6 (152)	single
D6HT100	6 (152)	double
D7HT100	7 (178)	double
D8HT100	8 (203)	double

Pre-assembled Dampers, Handles and Wing Nuts

28 Gauge (0.48 mm)

Catalog Number	Pipe Diameter in. (mm)	Bearing
D4AS	4 (102)	single
D5AS	5 (127)	single
D6AS	6 (152)	single
D7AS	7 (178)	single
D8AS	8 (203)	single
D6HTAS	6 (152)	double
D7HTAS	7 (178)	double
D8HTAS	8 (203)	double

Damper Regulator Hardware

- Fast installing hammer-on design.
- For use on 24-30 gauge steel.
- Standard 5/16" threads.
- Packaged 12 sets per bag.
- **Not for stove pipe:** Use only for air handling applications where temperature does not exceed 350°F (176°C).

DR25

Single Bearing/Fixed

- Contents: 1 fixed tip
• 1 inside washer
• 1 handle • 1 wing nut

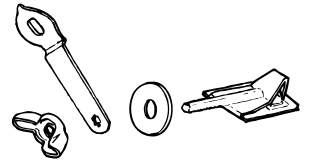

DR69

Single Bearing / Spring Loaded

- Contents: 1 spring bearing
• 1 inside washer
• 1 handle • 1 wing nut

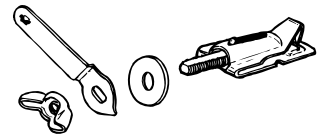

DR70

Double Bearing

- Contents: 2 spring bearings
• 1 inside washer
• 1 handle • 1 wing nut

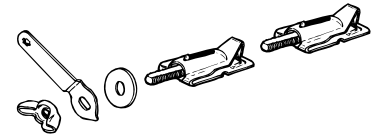

DR71

Double Bearing

- Contents: 1 spring bearing
• 1 fixed tip
• 1 inside washer
• 1 handle • 1 wing nut

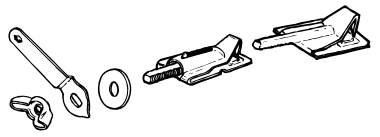

Bulk Components

DT516 (1000 pc. ctn.)
Head/Tail Piece, Fixed
(5/16" threads)

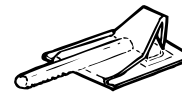

DRW (1000 pc. ctn.)
Inside Washer



H1100 (100 pack)
Damper Handle

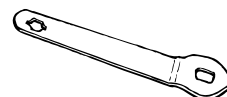

Flexible Duct Connector

Double fold "offset seams" offer superior locking power, tear resistance and added structural rigidity to the duct connection. Matched fingers allow easier cutting or bending without chewing fabric or metal.

Double Fold Offset Seams

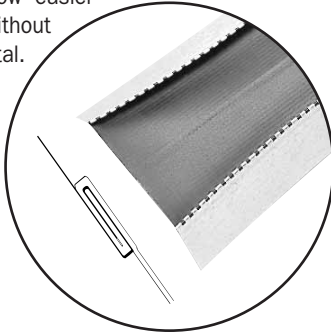

Matched Fingers

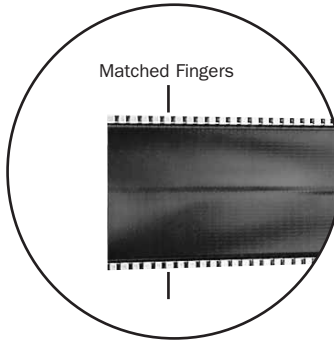

Neoprene Connector (Non Toxic)

Use with confidence on High Velocity and High Pressure HVAC systems, or where exposed to toxic fumes.

Specifications:

Basic Fabric:	Fiberglass Weave
Coating:	Neoprene
Tensile Strength:	275 x 260 psi
Burst Strength:	450 psi
Tear Strength:	50 x 45 lbs
Dimensions:	listed below
Steel Gauge:	listed below
Heat Range:	-35°F +235°F (-37°C +112°C)

Fire Rating: Self extinguishing fabric. Non toxic fumes. Emits minimal white, inorganic smoke. Meets National Fire Protection Association Standard 90A requirements for Duct Connectors. Meets ULC-S109 Large Scale Flame Test Requirements. UL Listed.

Other Outstanding Characteristics:

• Airtight • Waterproof • Resists Mildew • Resists Toxic Fumes • High Resistance to Broad Range of Chemicals, Acids, Alkalis and Oils.

Catalog Number	Steel Fabric Steel Widths in. (mm)	Coil Length ft. (m)	Steel Gauge (mm)	Application
CRN100	2x 3 x 2 (51 x 76 x 51)	100 (30.48)	28 (0.48)	Residential Quality
CCN100	3 x 3 x 3 (76 x 76 x 76)	100 (30.48)	24 (0.71)	Commercial/Industrial

Vinyl Connector

The economical choice for many HVAC applications. Can be used on both warm and cool sides of heating duct systems. Applicable for most commercial systems.

Specifications:

Basic Fabric:	Polyester Scrim
Coating:	Polyvinyl Chloride
Tensile Strength:	200 x 190 psi
Burst Strength:	350 psi
Tear Strength:	80 x 50 lbs
Dimensions:	listed below
Steel Gauge:	listed below
Heat Range:	-35°F +200°F (-37°C +95°C)

Fire Rating: Self extinguishing fabric. Meets National Fire Protection Association Standard 90A requirements for Duct Connectors and Standard 701 Large Scale Flame Test for Fabrics. Meets ULC-S109 Large Scale Flame Test Requirements.

Other Outstanding Characteristics:

• Airtight • Waterproof • Leakproof • Resists Moisture and Mildew • Resists Sunlight, UV Rays and Ozone • Abrasion Resistant

Catalog Number	Steel Fabric Steel Widths in. (mm)	Coil Length ft. (m)	Steel Gauge (mm)	Application
CRV100	2x 3 x 2 (51 x 76 x 51)	100 (30.48)	28 (0.48)	Residential Quality
CCV100	3 x 3 x 3 (76 x 76 x 76)	100 (30.48)	24 (0.71)	Commercial/Industrial

Pipe & Duct Holders

Like an extra pair of hands

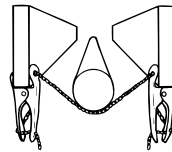

Holds duct in place, either between or under joists until properly secured.

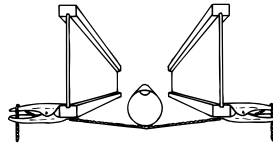
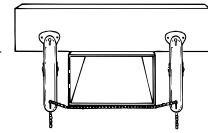

Holder also open wide and clamp securely for use on Engineered Wood Joists.



2DH

Two powerful clamps and four feet of 125 lb. tensile strength linked chain. Set holds duct in place, either between or under joists until it is properly secured. Also ideal for installing fiberglass duct, link chain will not puncture foil skin. Clamps and chain are nickel plated steel.

Catalog Number	Description
2DH	1 pair of clamps and chain



FasGroov[®]

Lay out ductboard as you cut with the FasGroov Fabricating System.

Single tools and full kits available for easy fabrication of all brands of 1-inch (25 mm) or 1-1/2-inch (38 mm) ductboard.

Malco's patented one-piece layout system incorporates a FasGroov Square with distinctive sled-style tools. Offsets built into square and tools allow you to lay out ductboard as you cut. Simply align dimensions on square with edge of previous cut and move across the board.

FasGroov[®] Square

Easy-to-use, easy-to-adjust anodized aluminum square.

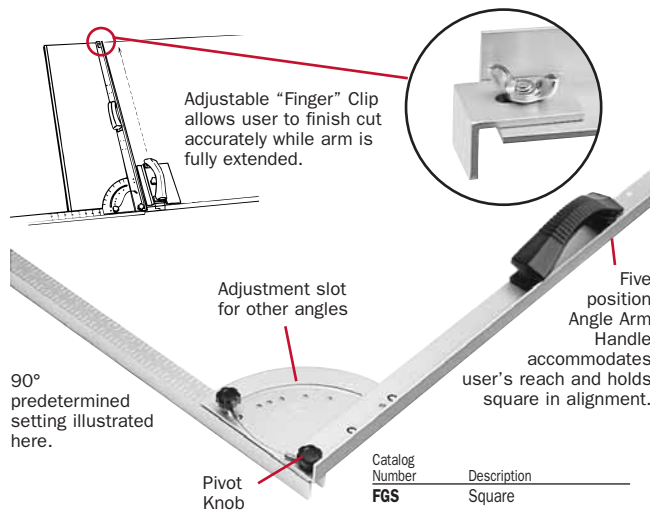

FasGroov[®] Hand Tools

Anodized aluminum sled-style tools for 1-inch and 1-1/2-inch ductboard. See page 38 for individual tool numbers and kits.

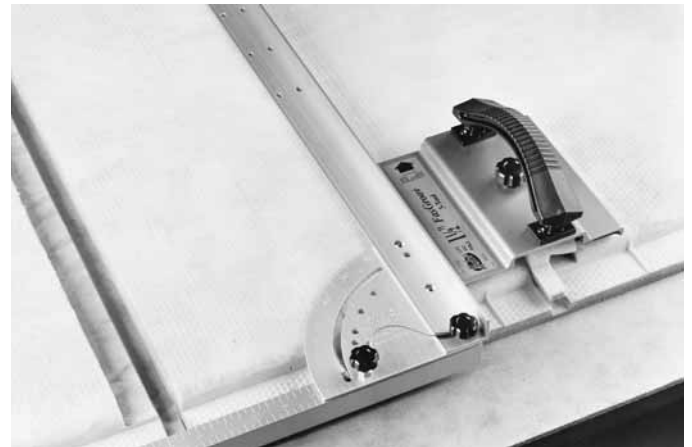
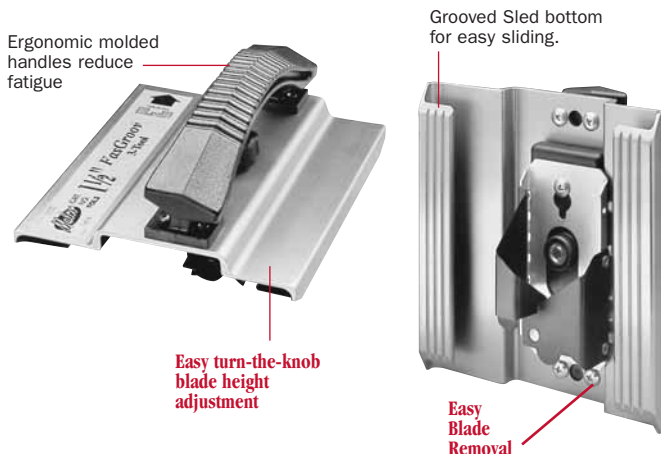

FasGroov[®] Knives

Safer to use with comfortable molded handles. Male and Female Shiplap Knives for 1-inch and 1-1/2-inch ductboard can be used on closed duct sections. Duct Knife features a rounded scoring edge to cut fiberglass without tearing skin. Plus, Malco's No. FG1 Hole Cutter and a special 1-1/2-inch blade No. KBHC are available separately for creating flex duct take-offs.

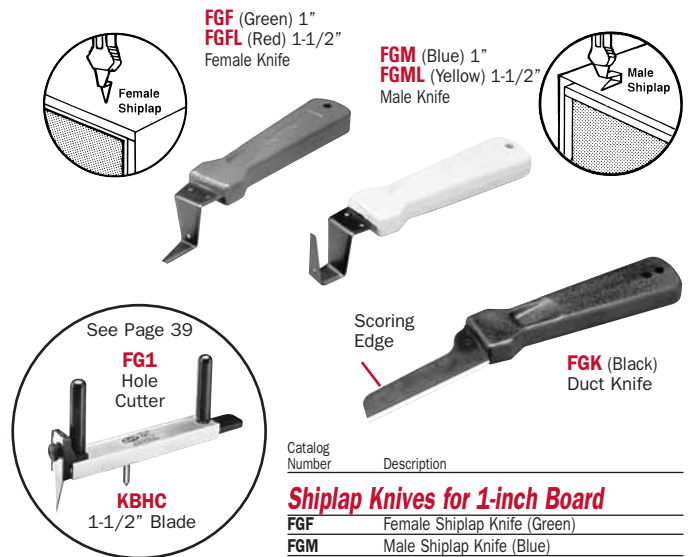

Shiplap Knives for 1-inch Board

FGF	Female Shiplap Knife (Green)
FGM	Male Shiplap Knife (Blue)

Shiplap Knives for 1-1/2-inch Board

FGFL	Female Shiplap Knife (Red)
FGML	Male Shiplap Knife (Yellow)

Ductboard Knife

FGK	Duct Knife (Black)
-----	--------------------

FasGroov® Hand Tools

	1-INCH (35 mm) SILVER TOOLS		1-1/2-INCH (38 mm) GOLD TOOLS							
	Catalog Numbers	Repl. Blade	Catalog Numbers	Repl. Blade						
<p>#1 Female Shiplap</p>	FGV1	FGV1RB	FGL1	FGL1RB						
<p>#2/4 R. Hand Shiplap</p>	FGV24	FGV24RB	FGL24	FGL24RB						
<p>#3 L. Hand Shiplap</p>	FGV3	FGV3RB	FGL3	FGL3RB						
<p>#5 Staple Flap</p>	FGV5	FGV5RB	FGL5	FGL5RB						
<p>Vee-Groove</p>	FGV	FGVRB	FGLV	FGLVRB						
<p>#6 Shiplap Trim Tool</p> <p>Use #6 Tool to shorten length of duct section, by measuring from outside edge of material to be scrapped. Available for 1-inch board only.</p>										
<table border="1"> <thead> <tr> <th>Catalog Number</th> <th>Description</th> <th>Repl. Blade Number</th> </tr> </thead> <tbody> <tr> <td>FGV6</td> <td>#6 Shiplap Trim Tool</td> <td>FGV6RB</td> </tr> </tbody> </table>	Catalog Number	Description	Repl. Blade Number	FGV6	#6 Shiplap Trim Tool	FGV6RB				
Catalog Number	Description	Repl. Blade Number								
FGV6	#6 Shiplap Trim Tool	FGV6RB								

FasGroov® Kits



See preceding page for description of FGS Square

KITS FOR 1-INCH DUCTBOARD

Shiplap Kit #FGSLK - Silver Hand Tools

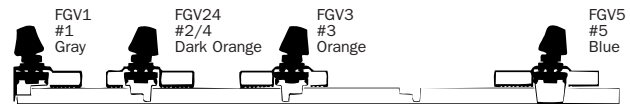

Includes: FGS Square and tools listed above plus FGK, FGM and FGF Knives and #6 Tool FGV6 in Tool Case.

Vee Kit #FGVK

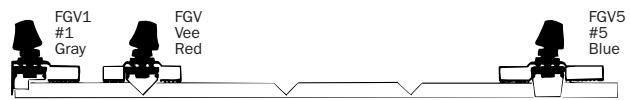

Includes: FGS Square and tools listed above plus FGK, FGM and FGF Knives and #6 Tool FGV6 in Tool Case.

KITS FOR 1-1/2-INCH DUCTBOARD

Shiplap Kit #FGSLKL - Gold Hand Tools

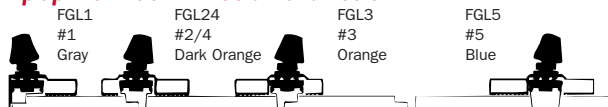

Includes: FGS Square and tools listed above plus FGK, FGML and FGFL Knives in Tool Case. Order FGSLKLW for Shiplap Kit WITHOUT Square.

Vee Kit #FGVKL



Includes: FGS Square and tools listed above plus FGK, FGML and FGFL Knives in Tool Case. Order FGVKLW for Vee Kit WITHOUT Square.



Fiberglass Duct Hole Cutter

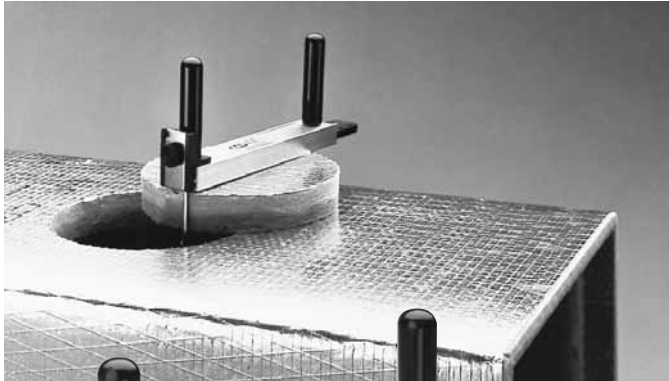

FG1



Makes precise holes in ductboard for flex duct take-offs.

Supplied with standard double point utility knife blade for cutting 1 inch board. USE SPECIAL No. KBHC BLADE FOR 1-1/2 INCH DUCTBOARD. Cuts 4" to 20" diameter holes in fiberglass ductboard. Operation is fast and easy. Cutter rotates counter clockwise on a center pivot punch. Durable extruded aluminum frame and engineering grade molded plastic and nylon components. Blade holder stores in body for safety and to protect blade from damage when not in use.

Catalog Number	Hole Diameter in. (mm)	Net Wt. oz. (g)
FG1	4 to 20 (102 to 508)	7.5 (213)

1-1/2-inch Ductboard Blade for FG1

KBHC	1-1/2" (38 mm) Blade for FG1 Hole Cutter
-------------	--

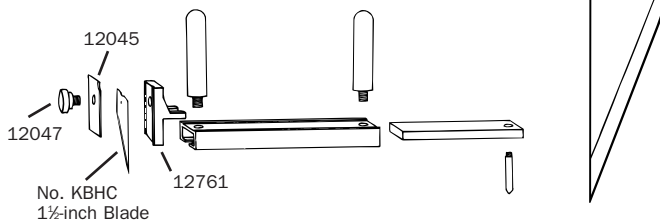

Replacement Parts for FG1

12761	Blade Holder
12045	Blade Clamp
12047	Blade Knob

Double Edge Duct Knife

DK1

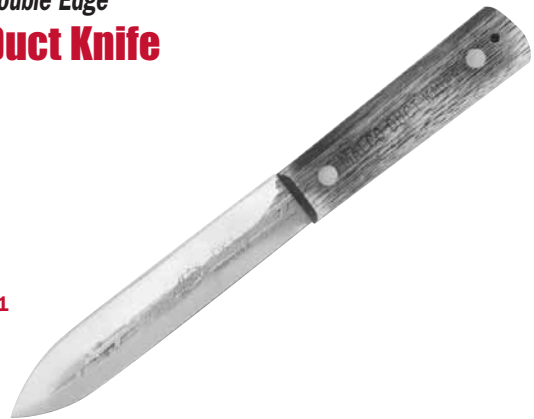

Use as an aid in fabricating fiberglass duct. Long life, double edge blade facilitates easy piercing for inside cuts. Double edge also ideal for tapping into and trimming flex duct. Resharpenable. Made of heavy cutlery steel with comfortable walnut wood handle.

Catalog Number	Description	Blade Length in. (mm)	Net Wt. oz. (g)
DK1	Double Edge Duct Knife	6 (152)	5 (142)

Leather Knife Sheath

TP301

Catalog Number	Description
TP301	Sheath for DK1 Duct Knife.

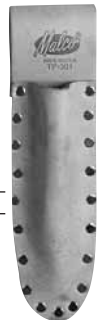

Washer Seals

For use with wire-reinforced ductboard walls. Volcano washers seat flush to ductboard surface. Washers are available with or without pre-applied Malco seals. Washers with pre-applied seals (FLWS) are fast installing and assure a proper seal around hole puncture and wire reinforcement to prevent air leakage and whistling.



Catalog Number	Description
FLW	2-1/2" x 2-1/2" x .030" (64 x 64 x 0.76 mm) galvanized reinforced volcano washer with 1/8" (3.18 mm) diameter hole.
FLWS	As above with pre-applied seals

Reinforcement Washer

Use with #8 screw for fastening sheet metal components to fiberglass duct.

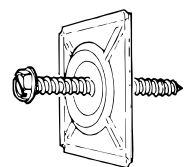

RW732	2-1/2" x 2-1/2" x .030" (64 x 64 x 0.76 mm) galvanized reinforced volcano washer with 7/32" (5.56 mm) diameter hole.
--------------	--



Fiberglass Duct Hole Cutter

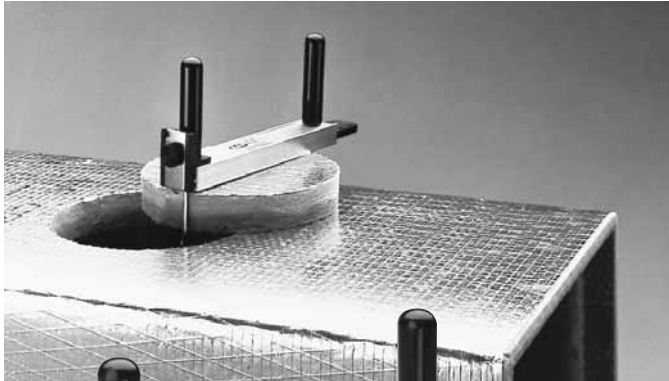

FG1



Makes precise holes in ductboard for flex duct take-offs.

Supplied with standard double point utility knife blade for cutting 1 inch board. USE SPECIAL No. KBHC BLADE FOR 1-1/2 INCH DUCTBOARD. Cuts 4" to 20" diameter holes in fiberglass ductboard. Operation is fast and easy. Cutter rotates counter clockwise on a center pivot punch. Durable extruded aluminum frame and engineering grade molded plastic and nylon components. Blade holder stores in body for safety and to protect blade from damage when not in use.

Catalog Number	Hole Diameter in. (mm)	Net Wt. oz. (g)
FG1	4 to 20 (102 to 508)	7.5 (213)

1-1/2-inch Ductboard Blade for FG1

KBHC	1-1/2" (38 mm) Blade for FG1 Hole Cutter
-------------	--

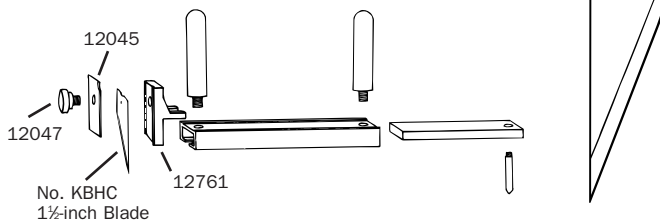

Replacement Parts for FG1

12761	Blade Holder
12045	Blade Clamp
12047	Blade Knob

Double Edge Duct Knife

DK1



Use as an aid in fabricating fiberglass duct. Long life, double edge blade facilitates easy piercing for inside cuts. Double edge also ideal for tapping into and trimming flex duct. Resharpenable. Made of heavy cutlery steel with comfortable walnut wood handle.

Catalog Number	Description	Blade Length in. (mm)	Net Wt. oz. (g)
DK1	Double Edge Duct Knife	6 (152)	5 (142)

Leather Knife Sheath

TP301

Catalog Number	Description
TP301	Sheath for DK1 Duct Knife.

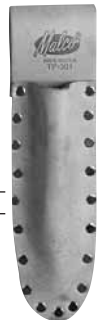

Washer Seals

For use with wire-reinforced ductboard walls. Volcano washers seat flush to ductboard surface. Washers are available with or without pre-applied Malco seals. Washers with pre-applied seals (FLWS) are fast installing and assure a proper seal around hole puncture and wire reinforcement to prevent air leakage and whistling.



Catalog Number	Description
FLW	2-1/2" x 2-1/2" x .030" (64 x 64 x 0.76 mm) galvanized reinforced volcano washer with 1/8" (3.18 mm) diameter hole.
FLWS	As above with pre-applied seals

Reinforcement Washer

Use with #8 screw for fastening sheet metal components to fiberglass duct.

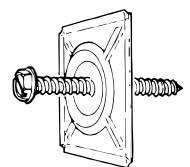

RW732	2-1/2" x 2-1/2" x .030" (64 x 64 x 0.76 mm) galvanized reinforced volcano washer with 7/32" (5.56 mm) diameter hole.
--------------	--



Adjustable, High Leverage Tensioning Tool with Auto-Cut-Off

Hardened steel stampings with weather resistant nickel chrome finish.

TY6



Vinyl cushion grips with hand stops

TENSIONING ADJUSTMENT KNOB AND AUTOMATIC CUT-OFF MECHANISM. Patent #'s 4,947,901 & 5,048,575

CAUTION: DO NOT OVERTIGHTEN. ADJUST KNOB ONLY WITH FINGERS.

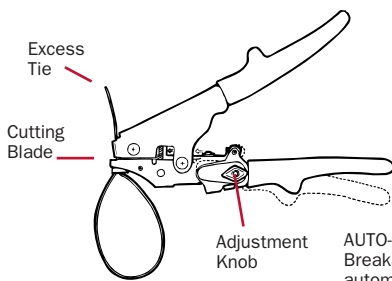

ALL MALCO TIE TOOLS ARE DESIGNED TO WORK ON STANDARD 175 LB TIES AS WELL AS THINNER 125 LB TIES.

AUTO-CUT-OFF
Breakaway spring mechanism automatically engages cut-off blade at desired tension setting.

For continuous use on-the-job. The TY6 Tensioning Tool is designed for a heavy user of nylon ties. An adjustment knob allows installer to set desired tension for securing flex duct to a take-off collar. When the tie is tight, a breakaway spring mechanism releases the tool's lower handle, causing the blade to engage and automatically flush cut off the excess tail of the nylon tie. No extra operation for manual trimming is required. Nylon tie installation is fast and easy with the TY6. Works on all ties including thin designs.

Operating the TY6 is easy on the installer tool! Contoured handles, with stops, are easier to grasp. Also, smooth lever action and vinyl cushion grips minimize hand and arm fatigue on big jobs.

The TY6 features a hardened steel body, long wearing parts, and a weather resistant nickel chrome finish to assure many years of dependable service.

Turn knob clockwise to increase tension and counterclockwise to decrease tension. Do not over-tighten. Adjust knob only with fingers to avoid breaking ties before cut-off occurs.



Catalog Number	Description	Length in. (mm)	Net Wt. oz. (g)
TY6	High Leverage Tie Tool	8-1/2 (216)	15 (425)



MANUAL CUT-OFF Tensioning Tools

TY4

TY4G

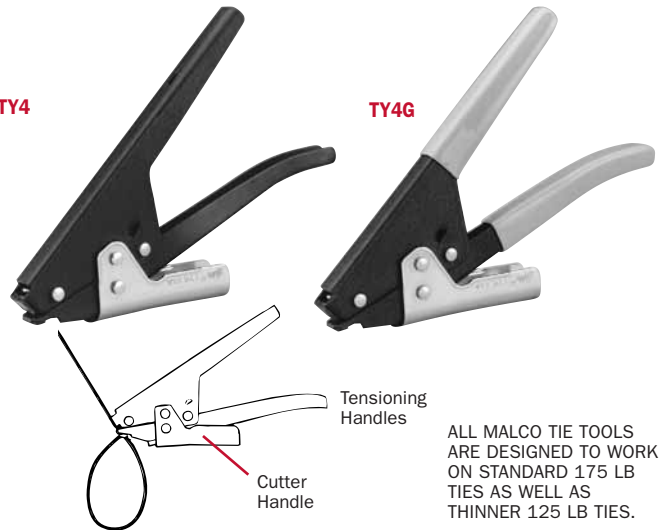

ALL MALCO TIE TOOLS ARE DESIGNED TO WORK ON STANDARD 175 LB TIES AS WELL AS THINNER 125 LB TIES.

These rugged lever action tie tools feature a unique notched gripper. A clean black baked on enamel wrinkle finish will also weather the elements and stand up to abuse on-the-job. Comfortable handles reduce the pinch point area, and gray vinyl cushion grips are available on the model TY4G. Works on all ties including thin designs.

Catalog Number	Description	Length in. (mm)	Net Wt. oz. (g)
TY4	Manual Cut-Off Tie Tool	6 (152)	10 (284)
TY4G	Manual Cut-Off Tie Tool /Gripped	6 (152)	11 (312)

Adjustable Nylon Ties



Use Malco Nylon Ties to install flexible duct to take-offs, or secure bundles, up to 15" diameter. Made of 100% nylon, Malco ties offer a minimal tensile strength of 175 pounds.

Catalog Number	Length in. (mm)	Width in. (mm)	Adjustable Dia. in. (mm)
TY34	36 (914)	3/8 (10)	to 10 (254)
TY48	48 (1219)	3/8 (10)	to 15 (381)

Tube Cutters



TC312



SPARE CUTTING WHEEL
Spare cutting wheel carried under retractable, locking reamer.



RETRACTABLE REAMER
Fold away tool steel reamer with turned cutting edge removes inside burrs cleanly. Filing surface removes outside burrs.

TC274

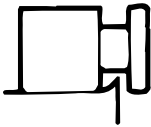

FLARE CUT-OFF GROOVE
Groove in roller reduces tube loss when cracked flare is removed.



BALL BEARING FEED
Ball bearing, enclosed feed mechanism provides easier operation, reduces friction.

For hard or soft copper tubing. Makes clean, right-angle cuts with no burrs or chips to clog tubing. Features ball bearing feed, flare cut-off groove, retractable reamer and spare cutting wheel. Rugged aluminum alloy body is designed for handling ease.

Conforms to federal specification GGG-C771d 1-31-64. Type II, Class 1, Style B.

Catalog Number	Tubing O.D. in. (mm)	Nominal Sizes inches
TC274	1/8 to 1-1/8 (4 to 28)	1/8 to 1
TC312	1/4 to 1-5/8 (7 to 41)	1/8 to 1-1/2

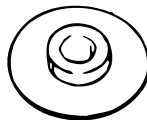

Replacement Cutting Wheels

Catalog Number	Description
RW274	Cutting wheel for TC274, TC312, TC174
75046	Cutting wheel for stainless fits TC274, TC312 and TC174
274TCS	Cutting wheel screw for TC274, TC312, TC174

Big Imp™ Tube Cutter

TC174

Tubing pivots on double rollers.



Compact cutter requires only 1-15/16" clearance, yet accommodates tubing from 3/8" to 1-1/8" O.D. (1/4" to 1" Nominal). Cuts copper, aluminum or brass, thin wall tubing. Lightweight aluminum alloy body. Spare cutter wheel included with tool.

Catalog Number	Tubing O.D. in. (mm)
TC174	3/8 to 1-1/8 (10 to 28)

Imp™ Tube Cutter

TC127

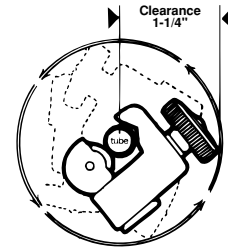

A handy tube cutter for cramped spaces so often encountered on installations or repairs. Only 1-11/16" x 1-15/16" x 7/8". Weighs only 2-1/2 oz. A mere 1-1/4" clearance is all that is needed to operate the "Imp".

Conforms to federal specification GGG-C771d, 1-31-64. Type 2, Class 2, Amendment 2.

Catalog Number	Tubing O.D. in. (mm)
TC127	1/8 to 5/8 (4 to 15)

Replacement Wheel

Catalog Number	Description
RW127	Cutting wheel for TC127
127TCS	Cutting wheel screw

SURE GRIP Tube Slicer

TC400



Produces cuts in ABS, PVC, rubber and fabric reinforced hose up to 1" I.D. Rigid, durable nylon handle design provides sufficient leverage when cutting so that only moderate hand pressure is required. Stainless steel cutting blade is resharpenable and replaceable.

Catalog Number	Description	Net Wt. oz. (g)
TC400	Plastic tube slicer	5 (142)
RB400	Replacement blade	-



Flaring Tools BAR CLAMP TYPE



FT195

Flares 7 sizes of soft copper, aluminum and brass tubing. Forged steel slip-on yoke and hardened flaring bar. Yoke design permits flaring where there is little space between nut and tube end. Positive clamping of bars prevents tube slippage. Hard chrome-finished swivel-type cone makes better flares with less effort. Satin finish nickel-chrome plated.

Conforms to federal specification GGG-G-451a, 6-13-68. Type 2, Class 2, Style A.

Catalog Number	Tubing O.D. in. (mm)	Nominal Sizes inches
FT195	3/16, 1/4, 5/16, 3/8, 7/16, 1/2, 5/8 (5, 6, 8, 10, 11, 13, 16)	1/8, 1/4, 3/8, 1/2

DIE BLOCK TYPE



FT500

For soft copper, aluminum and brass tubing. Faceted, hard chrome finished cone rolls out perfect 45° flares - then automatically burnishes flare face. Handy slip-on yoke permits use in tight quarters. Movable dies allow tubing to be slipped in easily. Heat treated dies grip tubing without scoring and the original tube wall thickness is maintained at base of flare. Satin chrome and black nickel finish.

Catalog Number	Tubing O.D. in. (mm)	Nominal Sizes inches
FT500	3/16, 1/4, 5/16, 3/8, 1/2, 5/8 (5, 6, 8, 10, 13, 16)	1/8, 1/4, 3/8, 1/2

ADJUSTABLE Flaring Tool

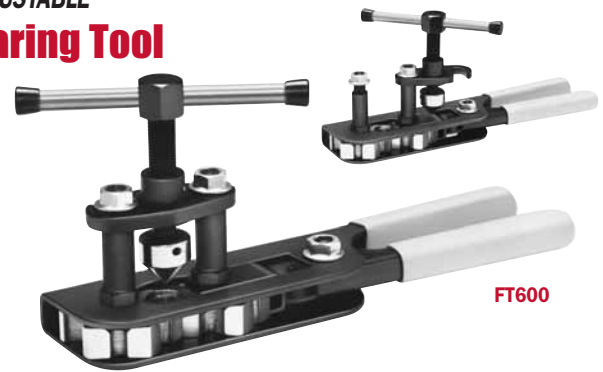

FT600

A rugged tool designed to flare a wide variety of tubing metals and sizes. Single lap flares are produced in brass, aluminum, copper and mild steel. Unique swing-away flare cone mount and moveable handle lever affords easy set up. Adjusting screw and lock nut assembly allows user to set desired gripping pressure to handle lever. Hardened steel tube clamps provide positive grip to prevent tube slippage. All steel construction with vinyl cushion grips.

Catalog Number	Tubing O.D. in. (mm)	Nominal Sizes inches
FT600	3/16, 1/4, 5/16, 3/8, 1/2, 5/8 (5, 6, 8, 10, 13, 16)	1/8, 1/4, 3/8, 1/2

COMBINATION Swaging Punches

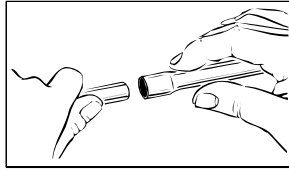

COMBINATION SWAGING PUNCH

Three sizes in one tool. Knurled stock for easy removal of punch.

Catalog Number	Tubing O.D. in. (mm)	Nominal Sizes inches
ST94	1/2, 5/8, 7/8 (13, 16, 22)	3/8, 1/2, 3/4

6-in-1 SWAGING TOOL

ST96	3/16, 1/4, 5/16, 3/8, 1/2, & 5/8" (5, 6, 8, 10, 13, 16)
------	---

Reamer-Deburring Tools

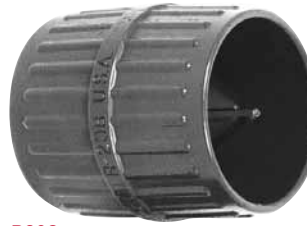

For copper, aluminum and brass tubing. Reams both inside and outside edges of tube with 3 hollow ground tool steel blades. Tool cuts when turned both clockwise and counter-clockwise. Fluted body is shaped to fit comfortably in palm.

R208

Catalog Number	Tubing O.D. in. (mm)	Nominal Sizes inches
R208	3/16 to 1-1/2 (5 to 38)	1/8 to 1-1/4

Pocket Size Deburring Tool



R308

Pocket size reamer deburrs nominal 1/4" or larger tubing and fittings. Freely rotating, hardened steel blade holds its edge in both copper and ABS/PVC plastic. Under 6" overall length.

Catalog Number	Description
R308	Pocket size, swivel reamer

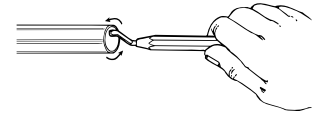

COPPER TUBE Fitting Brushes



Stainless steel fill. Comfortable plastic handle. For cleaning and burnishing all types of copper tubing. Assures strong, tight connections. Stainless steel, crimped fill with comfortable flat plastic handle.

Catalog Number	Nom. Tube Dia. inches	Actual Dia. in. (mm)	Brush Lgth. in. (mm)
FB1/2SS	1/2	5/8 (16)	1 (25)
FB3/4SS	3/4	7/8 (22)	1 (25)
FB1SS	1	1-1/8 (29)	1 (25)

Carbon steel crimped fill handle and stem

FB1/2	1/2	5/8 (16)	1 (25)
FB3/4	3/4	7/8 (22)	1 (25)
FB1	1	1-1/8 (29)	1 (25)



Plumbers Roll

ABRASIVE CLOTH



Specially processed for cleaning and preparing solder joint fittings.



Creates a bite on metal surface for solder or paint. Aluminum oxide cutting grain rates 9.2 on MO scale (diamond=10). Flexible cloth back fits contours of any surface configuration and hard to reach areas. Long lasting urea resin bonding is water resistant.

WHITE CLOTH Open coat, 120 grit alum. oxide.

Catalog Number	Description
AC110	1-1/2" x 10 yd. (38 mm x 9.14 m) white roll

BROWN CLOTH Closed coat, 120 grit alum. oxide.

AC310	1-1/2" x 10 yd. (38 mm x 9.14 m) brown roll
-------	---

ABRASIVE MESH

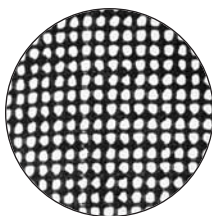

Actual Size of Weave

180 grit open mesh cleans with both sides, requires only light pressure, lasts twice as long as cloth. Scrim is nylon weave. Waterproof adhesive bonding. Will not clog, load or break down.

Catalog Number	Description
AC5M	1-1/2" x 5 yd. (38 mm x 4.57 m) mesh roll

Fin Straightening Tools

with Adjustable Nylon Combs



The FST tool straightens commonplace 8, 10, 12 or 14 fins per inch. Use the FST2 tool for straightening closely spaced 16, 18, 20 or 22 fins per inch. Both tools feature one-piece adjustable combs. The resilient nylon comb material will not damage the soft aluminum fins of condenser or evaporator units. Malco fin tools function by either pushing or pulling and efficiently straighten fins in tight quarters or where multiple passes over bent fins are required. Comfortable offset handles provide a sure grip and protect knuckles from scraping.

Catalog Number	Description
FST	Fin Straightening tool for 8, 10, 12 or 14 fins per inch
FST2	Fin Straightening tool for 16, 18, 20 or 22 fins per inch

Tube Benders



These budget priced tools are for bending soft tubing to any shape without collapsing walls. The special spring steel is zinc finished. One end is flared for quick tube insertion and removal. The 5 convenient sizes can be used economically for many jobs.

Catalog Number	Tubing O.D. in. (mm)
TB1024	1/4 (6)
TB1026	3/8 (10)
TB1028	1/2 (13)
TB1020	5/8 (16)
TB1022	3/4 (19)
TB102K	Set of above



Aluminum Levels

WITH TOP READ CENTER VIAL

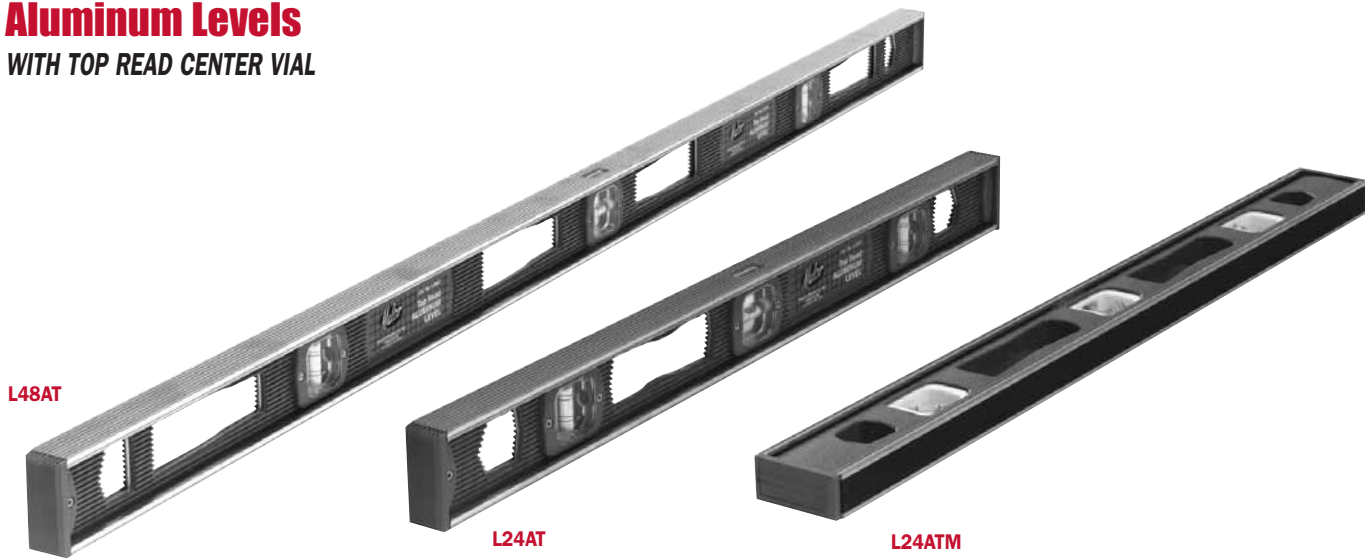

Strong and durable extruded aluminum frame is heat treated and grooved on both gauging surfaces. Unique construction design features multi-directional vial. Dust proof covers are screwed in to protect vial. Top read feature makes for quick, easy reading. Available in 24" and 48" lengths.

Catalog Number	Length in. (mm)	Number of Vials	I-Beam Stock Size in. (mm)
L24AT	24 (610)	3	1 x 2-1/8 (25 x 54)
L48AT	48 (1219)	3	1 x 2-1/8 (25 x 54)

MAGNETIC BASE

Holds firmly to metal surfaces, thus freeing hands. Magnetic strip is matched to milled aluminum edge for professional accuracy and exceptional holding power.

Catalog Number	Length in. (mm)	Number of Vials	I-Beam Stock Size in. (mm)
L24ATM	24 (610)	3	1 x 2-1/8 (25 x 54)

TOP READING

Torpedo Levels



Duplex milled aluminum frame with "cyclocac" end plates is lightweight and withstands shock or abuse. Precision cast parallel edges will not scratch work surface. Three large vials - plumb, level and 45°. White vial holders and top read feature facilitate quick, easy reading. Grooved working edge designed for use on pipe and conduit.

Catalog Number	Length in. (mm)	Number of Vials
L9	9 (229)	3

MAGNETIC BASE

Same description as above. Features magnetic strip on one side.

L9M	9 (229)	3
-----	---------	---

Pocket Level



Strong molded plastic frame with pocket clip. Multi view vial reads top, bottom or side. Ideal for leveling thermostats.

Catalog Number	Length in. (mm)	Number of Vials
L5	5 (127)	1



RELATED ITEMS
 More Torpedo Levels
 See **CREWLINE**
 Supplement **SL10650**



MEASURING TOOLS: Chalk Lines & Squares

SPEED

Chalk Reel

**100 foot Reel
rewinds
3-1/2
times faster!**

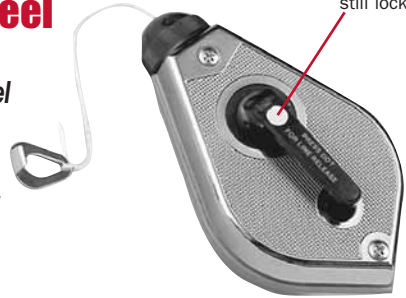

Press-in handle lets line out freely while still locked in place.

CLPS100

Large chalk capacity. Screw off cap prevents chalk leakage. Press-in handle feature lets line out freely, while handle is locked in place. Locking handle also allows use as a plumb bob. Durable high impact chrome plated case.

Catalog Number	Line Length ft. (m)
CLPS100	100 (30.48)

Chalk/Plumb Line

Chalk/plumb line marks on any surface, including wood, brick, stone and metal. Lightweight case is die-cast aluminum with baked enamel finish. Side action winding reel lock releases automatically on rewind. Hook ring holds line securely. Wedge lock plumb bob tip prevents chalk leakage, opens for quick, easy refilling. "Pop-in" line spool is easily replaceable.

CLP100



Catalog Number	Line Length ft. (m)	Replacement Spool Cat. No.
CLP100	100 (30.48)	CLR100



Powdered Chalk

Vibrant blue and permanent red chalk lays down a hard, clean line that won't blow away. Available in 8 oz. and big 5 lb. plastic dispensing bottles.

Catalog Number	Color	Net Wt.
C8B	Blue	8 oz.
C8R	Red	8 oz.

Framing Squares

SA24



SS24

STEEL RAFTER SQUARE

Professional steel square for all kinds of construction work - from roof rafting to building shelves. Body measures 24" x 2". Tongue is 16" x 1-1/2". Features frequently used measurement tables such as brace measure, octagon eight square scale and essex board measure. Square comes with hang-up hole on the tongue.

Catalog Number	Description	Net Weight
SS24	Steel rafter square	1 lb. 12 oz.

ALUMINUM RAFTING SQUARE

Lightweight aluminum frame. Body measures 24" x 2". Tongue is 16" x 1-1/2". Easy to read graduations on enamel surface. Also features reverse reading scale. Hang up hole on tongue.

Catalog Number	Description	Net Weight
SA24	Aluminum framing square	12 oz.

Combination Squares

12" with solid mounted vial



SCS12



SCS16

16" with scriber and pencil guide

360° View Vial

Machined head has self aligning zinc drawbolt for easy blade installation. Satin finish steel blades are precision stamped in eighths and sixteenths on each side. Level vials are durable acrylic. The SCS16 square also features a hardened scriber with brass bushing and pencil guide on blade.

Catalog Number	Description	Net Weight
SCS12	12" w/ solid mounted vial	12 oz.
SCS16	16" w/ scriber & pencil guide, 360° view vial	14 oz.

ALUMINUM

Straight Edge Rule

48AR



Made from .125 thickness extruded aluminum. This 48" rule is 2" wide. Large and clear, easy to read, thermo-bonded red markings on gray finish. Can be read from either end. Graduations in eighths and sixteenths.

Catalog Number	Description	Net Wt.
48AR	48" Straight Edge	16 oz.

Tinner's Circumference Rules



48BS
48CR



Standard bench rules with circumference readings for sheet metal work. Made from Stainless Steel which means they never need to be oiled. Fully etched markings are black filled for easy reading. 150 circumference inches in 1/8" increments both sides. Rules are 48" long x 1-1/4" wide.

Catalog Number	Lgth.	Upper Scale Graduations	Lower Scale Graduations
SEMI FLEXIBLE - .029" THICK			
48BS	48"	Increments to 1/16" both sides.	150 circumference inches in 1/8" increments both sides
HEAVY DUTY - .062" THICK			
48CR	48"	Increments to 1/16" both sides.	150 circumference inches in 1/8" increments both sides

Wood Folding Rules

606F

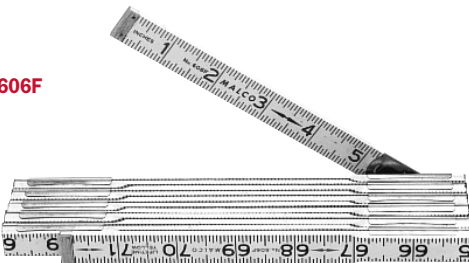

Milled from number 1 select hardwood stock. Rules are graduated on both edges in inches and sixteenths, with stud markings every 16 inches. Finish is coated with a clear protective film that resists oil, alkalis and acids. Concealed steel ball-lock joints are smooth action, long wearing and lubricated to prevent rule stretch. Joints, strike plates and tips are all brass plated.

Catalog Number	Lgth.	Net Wt.	Description	Color
606F	6 ft.	6 oz.	Inside read L to R	natural wood

RELATED ITEMS

Tape Measures, Long Tapes

See **CREWLINE**

Supplement **SL10650**



DISTANCE MEASURING WHEELS

For applications in heavy construction, specialty contracting trades, landscape design, irrigation installation, utility management, sport facility maintenance, agriculture, real estate, law enforcement, and more, there is a Malco Measuring Wheel that is ideally suited to your needs. Choose from a portable 6-inch model for smooth surface measurements to 1,000 feet, a versatile 10-inch model that reads up to 10,000 feet, or a rugged 19-inch wheel for accurate measurements over any terrain. All models feature long lasting, easy-to-read, gear driven counters with push-button resets. Polyvinyl wheel treads assure adequate traction on smooth or rough surfaces.



MW6
Portable 6-inch wheel is easy to store.

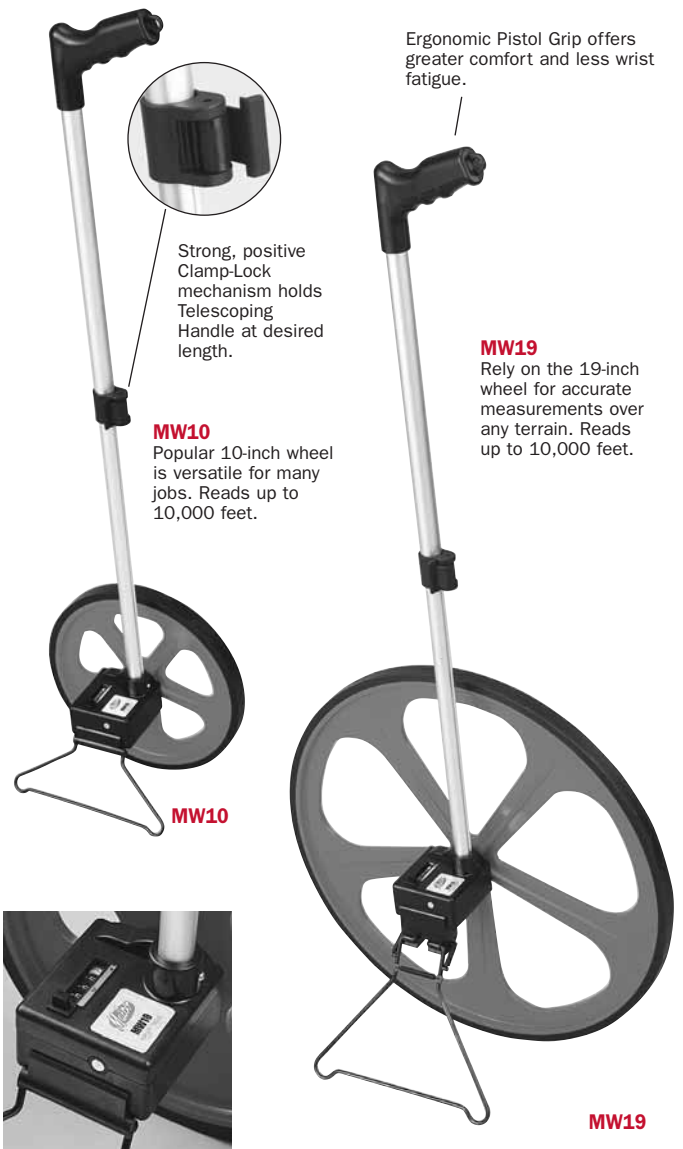

10-Inch and 19-Inch Measuring Wheels

5-Digit Counters to read up to 10,000 ft.
2-Section Telescoping Handles, with positive Clamp-Lock Mechanism. Ergonomic Pistol Grips. Handy Kickstands.



Catalog Number	Wheel Dia.	Nominal Circumference	Storage Lgth.	Extended Lgth.	Net Wt. Ea. lbs.
MW10	10"	3'	25"	41"	2.1
MW19	19"	5'	27"	40"	3.6

6-Inch Measuring Wheel

5-Digit Counter reads to 10,000 feet. 3-Section, Telescoping, Twist-and-Lock Handle. Hard-Sided Poly Carrying Case.

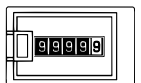

Catalog Number	Wheel Dia.	Nominal Circumference	Storage Lgth.	Extended Lgth.	Net Wt. Ea. lbs.
MW6	6"	1-1/2'	18"	39"	1.0

SAWS: Hack Saws



HIGH TENSION Hack Saw Frame

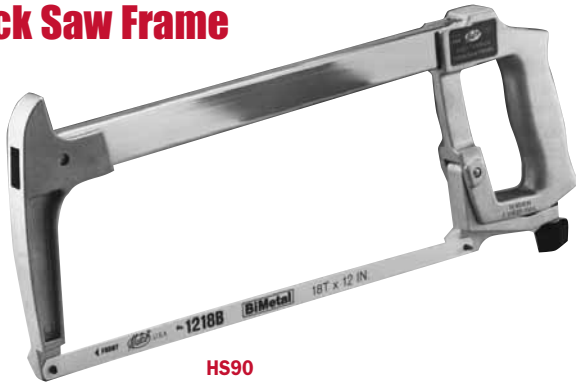

HS90

28,000 PSI TENSION FOR EASIER CUTTING AND LONGER BLADE LIFE.

Prevents Bi-Metal hacksaw blade from twisting and binding when cutting. Easy to adjust tension knob. Cast aluminum frame with tubular steel beam is rugged yet lightweight. Comfortable ergonomic handle. Convenient front end grip for better cutting leverage. Extra blades can store in tubular beam. Set screw will secure hacksaw blade or reciprocating saw blade for "jab sawing" in tight spots. Four permanent mounting pins allow both straight cutting and 45° angle for flush cutting.

Catalog Number	Description	Throat Depth in. (mm)	Net Wt. oz. (g)
HS90	High tension hack saw frame	4-3/8 - 5 (111 - 127)	26 (737)

Hack Saw Blades

BiMetal by Malco™

Shatterproof, versatile combination of high speed steel teeth and flexible carbon alloy back assures cleaner, faster, straighter cuts in any type of material. Out performs, outlasts standard carbon and high speed steel blades.

Catalog Number	Length in. (mm)	Width in. (mm)	Teeth Per in. (25.4 mm)	Thickness in. (mm)
1218B	12 (305)	1/2 (13)	18	.025 (0.64)
1224B	12 (305)	1/2 (13)	24	.025 (0.64)
1232B	12 (305)	1/2 (13)	32	.025 (0.64)



HIGH SPEED MOLYBDENUM STEEL

1224F	12 (305)	1/2 (13)	24	.025 (0.64)
1232F	12 (305)	1/2 (13)	32	.025 (0.64)

GENERAL PURPOSE CARBON STEEL

1218S	12 (305)	1/2 (13)	18	.025 (0.64)
1224S	12 (305)	1/2 (13)	24	.025 (0.64)
1232S	12 (305)	1/2 (13)	32	.025 (0.64)

THE ORIGINAL

Mini-Saw™

MS65

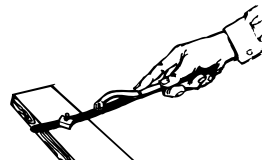

Extend and Flex Blade for Flush Cutting.

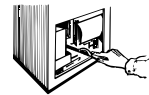

Use in Hard to Reach Places.

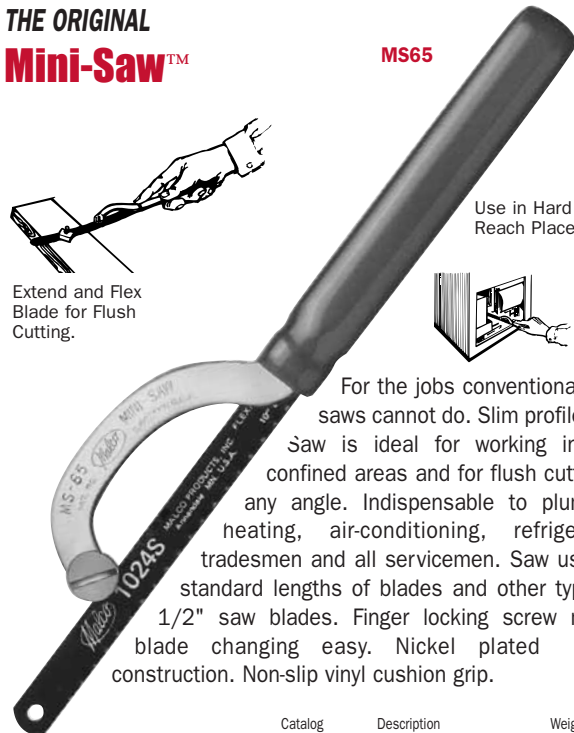

For the jobs conventional hack saws cannot do. Slim profile Mini-Saw is ideal for working in very confined areas and for flush cutting at any angle. Indispensable to plumbing, heating, air-conditioning, refrigeration tradesmen and all servicemen. Saw uses all standard lengths of blades and other types of 1/2" saw blades. Finger locking screw makes blade changing easy. Nickel plated steel construction. Non-slip vinyl cushion grip.

Catalog Number	Description	Weight oz. (g)
MS65	Mini-Saw	6 (170)



Compass Saw & Blades



CHW

Use laminated wood handle with either standard compass saw blade shown. Nickel wing nut facilitates easy change of blades. Blades may be reversed in handle for overhead cutting. Handle size fits large and small hands comfortably.

COMPASS SAW HANDLE ONLY

Laminated Wood

Stronger than ordinary grain cut handles. Will not break when dropped. Handle is sanded and coated with a clear gloss finish.

Catalog Number	Description
CHW	Wood handle only

COMPASS SAW BLADES ONLY

Manufactured from a special analysis high carbon steel, hardened and tempered for long life.



14CS



12CS

Description and Cutting Applications

For fast, clean accurate cuts through nails, metal lath, plasterboard, stucco, BX conduit and all types of wood. Teeth are generated on punch press. Each tooth is individually set and filed. Faces are filed square with backs filed to alternate 10° bevels.

Catalog Number	Length in. (mm)	Thickness in. (mm)	Teeth Per Inch (25.4 mm)
12CS	12 (305)	.060 (1.52)	10
14CS	14 (356)	.060 (1.52)	10

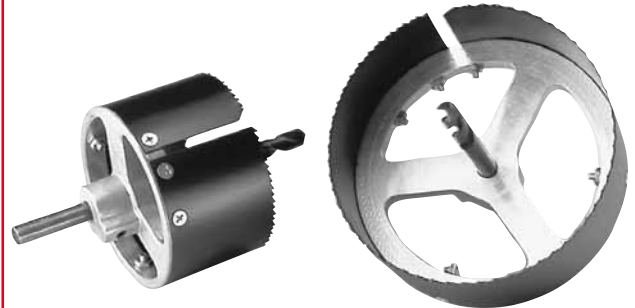

APPLICATION

DUCT PIPE APPLICATION

VENT HOOD

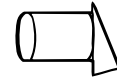

HSW68 for 4" Duct Pipe and Vent Hood Holes
HSW97 for 6" Duct Pipe and Vent Hood Holes

Designed for cutting all types of hard and soft wood, and other non-ferrous materials including plywood, composition board and siding.

The Malco VENT SAW® is **indispensable when fitting fresh air intakes** through foundation plates, exterior siding or facing materials encountered in residential or light commercial installations of gas or oil fired furnaces.

VENT SAW® features easily replaceable alloy steel blades and a versatile one piece arbor/mandrel combination made of high grade cast aluminum. **The webbed mandrel allows easy plug removal and a built-in arbor eliminates the need for separate arbor attachments.**

Catalog Number	Saw Diameter in. (mm)	Depth Of Cut in. (mm)	Replacement Blades
HSW68	4-1/4 (108)	2 (51)	RBW68
HSW97	6-1/4 (159)	2 (51)	RBW97
HSRD	7/16 (11) Dia. Replacement Drill		

BiMetal Hole in One™ HOLE SAW

Shatterproof alloy steel body.

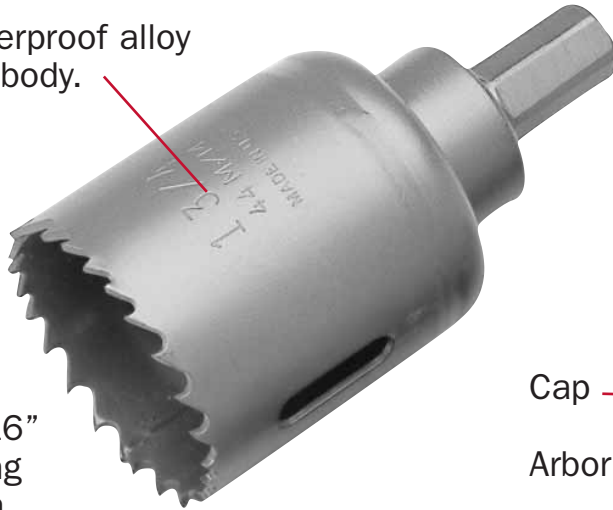

1-9/16"
Cutting
Depth

4/6 Variable Pitch
Teeth milled into high speed steel edge and microwelded to body. Varied tooth size permits an overall coarser pitch for more aggressive cutting.

Cap
Arbor

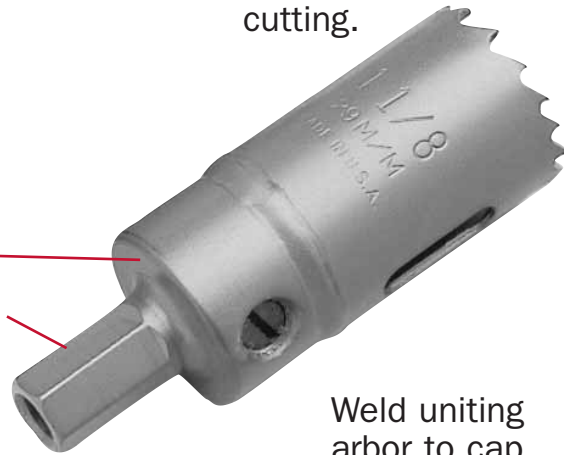

Weld uniting arbor to cap proven under extreme test conditions.

Featuring
SUPER SHARP, SUPER TOUGH
BiMetal By Malco™

The Hole Saw with the Built-in Arbor!

One piece arbor and hole saw combination eliminates the need for separate arbor attachments. 4/6 VARIABLE PITCH TEETH milled into high speed steel edge and micro-welded to body.

Hole-in-One Kit

Hole Saw selection, pilot drills, arbor extension and driver (for installing pilot) packaged in durable polypropylene case.



HSK

HSB



HSB Hole Saw 1/4" Pilot Drill Bit Replacements

Saw Extension

HSX



Catalog Number	Description
HSX	13" (330 mm) Arbor Extension fits Malco VENT SAW® and Hole-in One Hole Saws

Catalog Number	Description
HSK	Maintenance Hole in One Kit. One each of the following sizes: 2-1/2, 2-1/4, 2, 1-3/4, 1-1/2, 1-3/8, 1-1/8, 7/8 and 3/4". (64, 57, 51, 44, 38, 35, 29, 22, 19 mm) Plus (4) HSB drills, (1) HSX extension arbor shank and (1) stubby driver.



BiMetal Hole in One™ HOLE SAW

Catalog Number	Diameter Inches	mm	Recommended Clearance				RECOMMENDED (RPM) CUTTING SPEED					
			Pipe (I.D.) Tap Size	Entr. Size	Tubing (I.D.) Coupling	Entr. Size	Coupling	Mild Steel	Tool and Stainless Steel	Cast Iron	Brass	Alum.
H10	5/8	15.8	-	-	-	1/4	-	550	275	365	730	825
H11	11/16	17.5	-	-	-	-	-	500	250	330	665	750
H12	3/4	19.0	-	-	-	3/8	-	460	230	300	600	690
H14	7/8	22.2	3/4	1/2	-	5/8	-	390	195	260	520	585
H15	15/16	23.8	-	-	-	-	-	370	185	245	495	555
H16	1	25.4	-	-	1/4	3/4	1/2	350	175	235	470	525
H17	1-1/16	27.0	-	-	-	-	-	325	160	215	435	480
H18	1-1/8	28.6	1	3/4	3/8	-	-	300	150	200	400	450
H19	1-3/16	30.2	-	-	-	-	-	285	145	190	380	425
H20	1-1/4	31.8	-	-	1/2	1	3/4	275	140	180	360	410
H21	1-5/16	33.3	-	-	-	-	-	260	136	175	345	390
H22	1-3/8	34.9	-	1	-	-	-	250	125	165	330	375
H24	1-1/2	38.1	1-1/4	-	3/4	1-1/4	1	230	115	150	300	345
H26	1-5/8	41.3	-	-	-	-	-	210	105	140	280	315
H28	1-3/4	44.5	1-1/2	1-1/4	-	1-1/2	1-1/4	195	95	130	260	295
H30	1-7/8	47.6	-	-	-	-	-	180	90	120	240	270
H32	2	50.8	-	1-1/2	-	-	1-1/2	170	85	115	230	255
H33	2-1/16	52.4	-	-	-	-	-	165	80	110	220	245
H34	2-1/8	54.0	-	-	-	-	-	160	80	105	210	240
H36	2-1/4	57.2	2	-	1-1/4	2	-	150	75	100	200	230
H38	2-3/8	60.3	-	-	-	-	-	140	70	95	190	220
H40	2-1/2	63.5	-	2	1-1/2	-	-	135	70	90	180	205
H42	2-5/8	66.7	-	-	-	-	-	130	65	85	170	195
H44	2-3/4	69.9	-	-	-	2-1/2	-	125	60	80	160	185
H46	2-7/8	73.0	-	-	-	-	-	120	60	80	160	180
H48	3	76.2	-	2-1/2	2	-	2-1/2	115	55	75	150	170
H50	3-1/8	79.4	-	-	-	-	-	110	55	70	145	165
H52	3-1/4	82.6	3	-	-	3	-	105	50	70	140	155
H56	3-1/2	88.9	-	-	-	-	-	95	45	65	125	145
H58	3-5/8	92.1	-	3	-	-	3	95	45	60	120	140
H64	4	101.6	-	-	2-1/2	3-1/2	3-1/2	85	40	55	115	125
H66	4-1/8	104.2	-	3-1/2	-	-	-	85	40	55	110	120
H68	4-1/4	108.0	-	-	-	-	-	80	40	55	110	115
H72	4-1/2	114.3	-	4	3	4	-	75	35	50	100	105
H80	5	127.0	-	-	-	-	-	65	30	40	85	90

All sizes feature 4/6 VARIABLE PITCH TEETH for aggressive cutting in all machinable materials.

SAWS: Reciprocating Saw Blades



A full line selection of Reciprocating Saw Blades featuring **SUPER SHARP, SUPER TOUGH**

BiMetal By Malco™



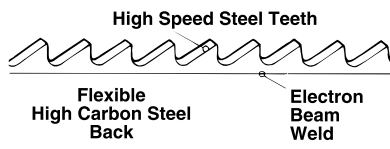

THEY STACK UP BETTER: For wood with nails, metal pipe, angles, and a variety of specialty applications from drywall to drain pipe, BiMetal By Malco stacks up best against the rest. These shatterproof blades are formulated from a premium metal composition consisting of a High Speed Steel cutting edge micro welded to a flexible High Carbon Steel back. Wood Cutting BiMetal blades are available in a wide variety of profiles and tooth combinations to match cutting speed, plus control and maneuverability needed for the job. Wide 3/4" profiles on Metal Cutting BiMetal combine with superior manufacturing processes to outperform and outlast all other similar blades in head to head comparisons.



Catalog Number	Nominal L x W x Thickness inches (mm)	Teeth Per inch (25.4 mm)	Tooth Set	Tooth Form	Cutting Edge	Description / Application
----------------	---------------------------------------	--------------------------	-----------	------------	--------------	---------------------------



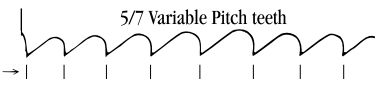
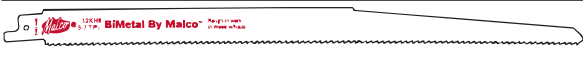

WOOD CUTTING BLADES

BiMetal By Malco™

 4DL6	6 x 5/8 x .050 (152 x 16 x 1.27)	6	Alternate	Standard	Milled	DELUXE CONTOUR 4DL6 used for rough-in, contours in wood with nails.
 4KH6	6 x 3/4 x .059 (152 x 19 x 1.50)	5/7	Alternate	Variable / Standard	Milled	KEYHOLE PROFILE -- VARIABLE PITCH Varied tooth sizes permit an overall coarser pitch for aggressive cutting in wood with nails.
 8KH7	9 x 3/4 x .049 (229 x 19 x 1.24)	5/7	Alternate	Variable / Standard	Milled	 4KH6, 8KH7, 12 KH8 used for rough-in, mild contours in wood with nails.
 12KH8	12 x 3/4 x .049 (305 x 19 x 1.24)	5/7	Alternate	Variable / Standard	Milled	
 4KH8	6 x 3/4 x .049 (152 x 19 x 1.24)	8	Alternate	Standard	Milled	KEYHOLE PROFILE 4KH8 produces less vibration, smoother, cleaner cuts in wood with nails, composition board.
 4GT7	6 x 5/8 x .031 (152 x 16 x 0.79)	6	Alternate	Standard	Milled	STRAIGHT PROFILE 4GT7 used for smooth cutting in hard and soft wood, composition board.

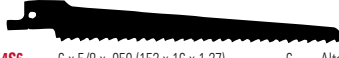
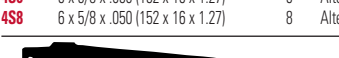
WOOD CUTTING BLADES

HCS (High Carbon Steel)

 4S6	6 x 5/8 x .050 (152 x 16 x 1.27)	6	Alternate	Standard	Milled	SUPREME CONTOUR -- FLEAM SHARPENED Teeth are fleam sharpened (alternate ground set) for fast feeding, clean shearing action. 4S6 is fastest cutting blade for rough-in, contours in nail free wood. 4S8 used for rough-in, contours in wood with nails.
 4S8	6 x 5/8 x .050 (152 x 16 x 1.27)	8	Alternate	Standard	Milled	
 4KH7	6 x 3/4 x .049 (152 x 19 x 1.24)	6	Alternate	Standard	Ground	KEYHOLE PROFILE -- FLEAM SHARPENED Teeth are fleam sharpened (alternate ground set) for fast feeding, clean shearing action. 4KH7 used for rough-in, mild contours in nail free wood.
 12KH7	12 x 3/4 x .049 (305 x 19 x 1.24)	6	Alternate	Standard	Ground	KEYHOLE PROFILE 12KH7 used for rough-in, mild contours in nail free wood.
 8PWB	8 x 3/4 x .050 (203 x 19 x 1.27)	Progr.	Alternate	Variable / Progressive	Ground	PLUNGE CUT TIP - PROGRESSIVE PITCH Smaller teeth near blade shank and larger teeth at tip for faster cuts / longer life. 8PWB is a High Carbon Steel, PROGRESSIVE PITCH blade used for making fast, clean cuts in wood and composite material.



PLASTER BLADE

BiMetal By Malco™

 4P6	6 x 3/4 x .049 (152 x 19 x 1.24)	6	Alternate	"V"	Milled	STRAIGHT PROFILE - "V" TOOTH 60° angle "V" tooth cuts on both forward and backward stroke. 4P6 used for continuous cutting in plaster, sheetrock and metal lath.
--	----------------------------------	---	-----------	-----	--------	---

GENERAL PURPOSE BLADE

BiMetal By Malco™









 4GT10	6 x 3/4 x .031 (152 x 19 x 0.79)	10	Alternate	Standard	Milled	STRAIGHT PROFILE 4GT10 used for cuts in wood with nails or metals > 3/16".
 8PAP	8 x 3/4 x .051 (203 x 19 x 1.30)	Progr.	Wavy	Special Progressive	Milled	PLUNGE CUT TIP - PROGRESSIVE PITCH Smaller teeth near blade shank and larger teeth at tip for faster cuts / longer life. 8PAP is a BiMetal, PROGRESSIVE PITCH blade used for making fast cuts in wood, wood with nails, non-ferrous metals (including aluminum and brass), plastic and fiberglass. This durable blade offers outstanding performance in thick or thin materials.

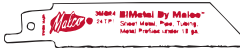

SELECTION TIPS

Selecting the right blade for the job is critically important. Factors that should be considered are:

1. Type and hardness of material to be cut, which will determine the tooth form, thickness and material composition of the blade to be used.
2. Size and variation in cross section of stock to be cut which dictates the pitch of the teeth (or teeth per inch) required, tooth set and blade length.
3. Type of cut, whether straight, contour or both will determine blade width.

Catalog Number	Nominal L x W x Thickness inches (mm)	Teeth per in. (25.4 mm)	Tooth Set	Tooth Form	Cutting Edge	Description /Application
METAL CUTTING BLADES BiMetal By Malco™						
	STRAIGHT PROFILE -- HIGH SPEED CUTTING 4TF14 used for metals, including stainless over 1/8".					
4TF14	6 x 3/4 x .031 (152 x 19 x 0.79)	14	Raker	Standard	Milled	
	STRAIGHT PROFILE -- HIGH SPEED CUTTING 3TF18, 4TF18 used for 18 gauge to 1/8" metals.					
3TF18	4 x 3/4 x .031 (102 x 19 x 0.79)	18	Raker	Standard	Milled	
	STRAIGHT PROFILE -- HIGH SPEED CUTTING 3MC24, 4MC24 used for metal sheet, pipe, profiles under 18 ga.					
4TF18	6 x 3/4 x .031 (152 x 19 x 0.79)	18	Raker	Standard	Milled	
	STRAIGHT PROFILE -- HIGH SPEED CUTTING 3MC24, 4MC24 used for metal sheet, pipe, profiles under 18 ga.					
3MC24	4 x 3/4 x .031 (102 x 19 x 0.79)	24	Wavy	Standard	Milled	
	STRAIGHT PROFILE -- HIGH SPEED CUTTING 3MC24, 4MC24 used for metal sheet, pipe, profiles under 18 ga.					
4MC24	6 x 3/4 x .031 (152 x 19 x 0.79)	24	Wavy	Standard	Milled	
	STRAIGHT PROFILE -- VARIABLE PITCH 9MC10 used for pipe diameters to 4" O.D. (NOTE: Do not use to cut waste stack.)					
9MC10	9 x 3/4 x .050 (229 x 19 x 1.27)	10/14	Raker	Variable / Standard	Milled	
	PLUNGE CUT TIP - PROGRESSIVE PITCH Smaller teeth near blade shank and larger teeth at tip for faster cuts / longer life. 6PMC is a BiMetal, PROGRESSIVE PITCH blade used for making fast, clean cuts in thick or thin material including non-ferrous metals, galvanized sheet metal, copper and steel pipe, and steel and aluminum profiles. This shatterproof blade offers maximum on-the-job performance and long service life.					
6PMC	6 x 3/4 x .037 (152 x 19 x 0.94)	Progr.	Wavy	Variable / Standard / Progressive	Milled	
	SCROLL BLADE 2MS18 used for scroll cuts in metals to 1/8".					
2MS18	3/2 x 1/4 x .031 (89 x 6 x 0.79)	16	Raker	Standard	Milled	
METAL CUTTING BLADES HSS (High Speed Steel)						
	STRAIGHT PROFILE -- HIGH SPEED CUTTING 4MC14 used for metals over 1/8". 4MC18 used for 18 gauge to 1/8" metals.					
4MC14	6 x 5/8 x .031 (152 x 16 x 0.79)	14	Raker	Standard	Milled	
4MC18	6 x 5/8 x .031 (152 x 16 x 0.79)	18	Raker	Standard	Milled	
CARBIDE GRIT BLADE HCS (High Carbon Steel)						
	STRAIGHT PROFILE -- CARBIDE GRIT CUTTING EDGE 8CG used for soil pipe, cast iron, ceramic tile and brick.					
8CG	8 x 3/4 x .040 (203 x 19 x 1.02)	---	---	Carbide Grit	---	

SAWS: Circular Saw Blades



Trade Saw™ CIRCULAR SAW BLADES

Professional™ Edge CIRCULAR SAW BLADES



B725PP
186 TOOTH PLYWOOD FINISHING
Precision ground for smooth cuts in plywood, siding and plastic materials.

**CONTRACTOR GRADE - ELECTRIC CHROME PLATED BLADES
OUTLAST UNPLATED STEEL.**

Catalog Number	Dia. in. (mm)	Arbor	RPM	Teeth
B725PP	7-1/4 (184)	Univ.	6500	186



ALUMINUM & PLASTIC:
For Aluminum sheets, tubing, siding and other nonferrous metals; vinyl siding, other plastics-composites; formica, etc.

Catalog Number	Dia. in. (mm)	Arbor	RPM	Teeth
C700AP	7 (178)	Univ.	5800	150

Abrasive Blades



B700PMA
MASONRY CUTTING
Bonded silicon carbide for fast cuts in bricks, block and tile.



PLYWOOD & VENEER:
For clean cuts in plywood, veneer, thin plastics and cellotex.

Catalog Number	Dia. in. (mm)	Arbor	RPM	Thickness in. (mm)
B700PMA	7 (178)	Univ.	7600	1/8 (3)

Catalog Number	Dia. in. (mm)	Arbor	RPM	Teeth
C725P	7-1/4 (184)	Univ.	5800	150



B700PME
METAL CUTTING
Bonded aluminum oxide for cutting light metals, aluminum and other ferrous metal products.



REGULAR COMBINATION:
For smooth, fast cutting in any direction through wood grain.

Catalog Number	Dia. in. (mm)	Arbor	RPM	Thickness in. (mm)
B700PME	7 (178)	Univ.	7800	1/8 (3)

Catalog Number	Dia. in. (mm)	Arbor	RPM	Teeth
C725C	7-1/4 (184)	Univ.	5800	26

Utility Knives

SIDE BUTTON ACTION

3PK



Retractable blade advances to three locked cutting positions with the aid of push button. Lightweight, strong handle is contoured to the hand for easy, controlled use.

Catalog Number	Description
3PK	3 position utility knife (side button)

TOP BUTTON ACTION

4PK



Die-cast heavy duty model comes complete with 3 double point blades. Safe, easy to operate, thumb action mechanism on top facilitates three cutting positions - fully extended, partially extended for carton opening and intermediate.

4PK	3 position utility knife (top button)
-----	---------------------------------------

Quick Open Knife

9PK



"No tools" blade change is fast and easy with just a turn of the knob. Extra blades store in handle. Retractable blade advances to "3 locked cutting positions" with aid of thumb button. Heavy duty, die-cast knife halves feature "integrated hinge" to eliminate lost or dropped parts. Contoured knife shape features "ergonomic safety grip". Comes with one blade in retracting mechanism.

Catalog Number	Description
9PK	Quick Open Utility Knife

Mini-Knife®

3PKM



Chrome plated steel with handy key chain. Stores 5 blades.

Catalog Number	Description
3PKM	Mini-Knife with retractable blade.

MINI-KNIFE® BLADES

Catalog Number	Description
KBM	Carded 5-pack, Mini-Knife Blades

RELATED ITEMS

More Utility Knives & Blades
See **CREWLINE**
Supplement SL10650

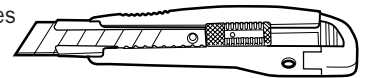

CBAUK Break-away utility Knife

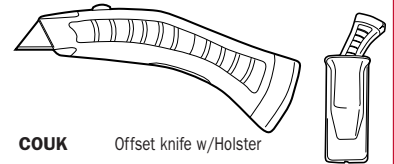

COUK Offset knife w/Holster

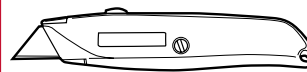

CEUK Economy utility Knife



CSUK 3-Position utility Knife



CRUK Roofer's Knife



CBAB (10 pack)

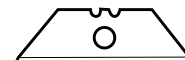

CSB (100 pack)
CSB5 (5 pack)



CHB (100 pack)
CHB5 (5 pack)

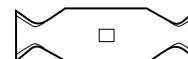

CBT (100 pack)
CBT5 (5 pack)



Sheet Metal Hammers

VINYL GRIPPED

One-piece forged, I-beam construction. Full-polished heads are corrosion resistant. Hammer sections are individually hardened and tempered for strength and resiliency. Molded-on vinyl grips minimize recoil and offer excellent comfort, non-slip gripping and durability.



Catalog Number	Head Weight oz. (g)	Head Length in. (mm)	Face Size in. (mm)	Nominal O/A Length in. (mm)
RH4V	12 (340)	4-7/8 (124)	3/4 (19)	11 (279)



Catalog Number	Head Weight oz. (g)	Head Length in. (mm)	Face Size in. (mm)	Nominal O/A Length in. (mm)
SH3V	18 (510)	5-1/2 (140)	7/8 (22)	11-3/4 (298)

LEATHER GRIPPED

One-piece forged, I-beam construction



Catalog Number	Head Weight oz. (g)	Head Length in. (mm)	Face Size in. (mm)	Nominal O/A Length in. (mm)
RH4	12 (340)	4-7/8 (124)	3/4 (19)	11 (279)



Catalog Number	Head Weight oz. (g)	Head Length in. (mm)	Face Size in. (mm)	Nominal O/A Length in. (mm)
SH3	18 (510)	5-1/2 (140)	7/8 (22)	11-3/4 (298)

WOOD HANDLED

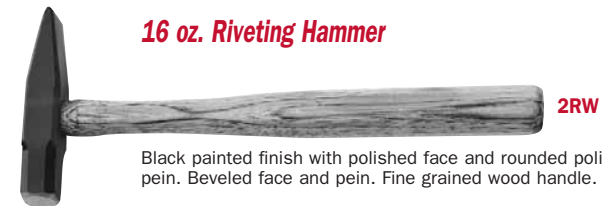

Catalog Number	Head Weight oz. (g)	Head Length in. (mm)	Face Size in. (mm)	Nominal O/A Length in. (mm)	Replacement Handle #
2RW	16 (454)	5 (127)	1 (25)	13-1/4 (337)	WH23



Catalog Number	Head Weight oz. (g)	Head Length in. (mm)	Face Size in. (mm)	Nominal O/A Length in. (mm)	Replacement Handle #
2SW	16 (454)	5 (127)	1 (25)	13 (330)	WH23

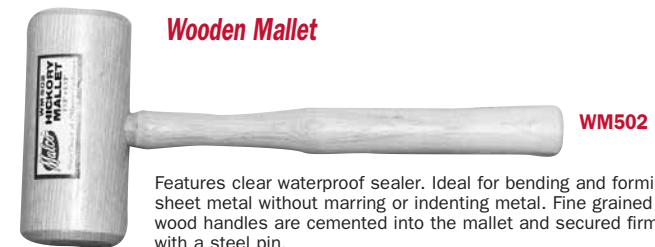

Catalog Number	Head Weight oz. (g)	Head Length in. (mm)	Face Size in. (mm)	Nominal O/A Length in. (mm)
WM502	16 (454)	5-1/2 (140)	2-1/2 (64)	13 (330)

Shinglers Hammer



Milled face and 1-13/16" cutting edge with stop gauge and retractable blade. One-piece forged I-beam construction, molded-on vinyl grip and leather safety strap.

Catalog Number	Cutting Edge in. (mm)	Nominal O/A Length in. (mm)
SHV	1-13/16 (46)	12-1/2 (318)

Replacement Parts

SHB	Replacement Blade
SHG	Replacement Gauge
SHS	Replacement Screw

Claw Hammers



One-piece forged, I-beam construction. Full polished head with beveled face. Comfortable, non-slip vinyl grip.

Catalog Number	Claw	Head Wt. oz. (g)	Head Length in. (mm)	Face size in. (mm)	Nominal O/A Length
16SCV	straight	16 (454)	4-7/8 (124)	1-1/16 (27)	12-1/2 (318)
20SCV	straight	20 (567)	5-5/8 (143)	1-3/16 (30)	12-1/2 (318)



One-piece forged, I-beam construction. Full polished head with beveled face.

Catalog Number	Claw	Head Wt. oz. (g)	Head Length in. (mm)	Face size in. (mm)	Nominal O/A Length
16CC	curved	16 (454)	4-1/4 (108)	1-1/16 (27)	12-1/2 (318)
16SC	straight	16 (454)	4-7/8 (124)	1-1/16 (27)	12-1/2 (318)
20CC	curved	20 (567)	5 (127)	1-3/16 (30)	12-1/2 (318)
20SC	straight	20 (567)	5-5/8 (143)	1-3/16 (30)	12-1/2 (318)



Black paint and polished finish with chamfered edges and beveled face. Fiberglass minimizes recoil and vinyl grip adds comfort.

Catalog Number	Claw	Head Wt. oz. (g)	Head Length in. (mm)	Face size in. (mm)	Nominal O/A Length
16CCF	curved	16 (454)	5-1/4 (133)	1 (25)	13 (330)
16SCF	straight	16 (454)	5-1/2 (140)	1 (25)	13 (330)
20SCF	straight	20 (567)	6 (152)	1-1/16 (27)	13 (330)

Ball Pein Hammer



Black painted finish with polished face and pein. Faces are beveled. Fine grained wood handle.

Catalog Number	Head Wt. oz. (g)	Length in. (mm)	Face Size in. (mm)	Nominal O/L Length in. (mm)
BP8W	8 (227)	3-3/8 (86)	1 (25)	12-1/4 (311)

Engineers Hammer



Double faced hammer. Black painted finish with polished faces and bevels. Fits easily in tool box! Fine grained wood handle.

Catalog Number	Head Wt. lbs. (kg)	Length in. (mm)	Face Size in. (mm)	Nominal O/L Length in. (mm)
SLH250	2.5 (1.13)	4-1/2 (114)	1-5/8 (41)	15-1/2 (394)

Pry Bars



Handy Bar

Wide, thin tapered design for easy mar-proof prying. Half round heel provides easy rocking action.



I-Beam Pry Bar

I-Beam construction gives superior strength, yet is lightweight for less worker fatigue. Polished double hammer faces.

Catalog Number	Nominal Length in. (mm)	Net Wt. oz. (g)
HB15	14-1/2 (368)	24 (680)
PB18	18 (457)	22 (624)

Long Nose Pliers



LNC6G

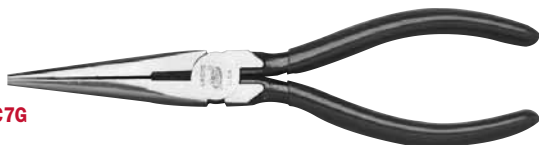

LNC7G

Long reach cutter style pliers are suited for a variety of jobs. Jaws comprise 1/3 of total length. Smooth functioning box joint insures accurate alignment of cutter edges. Milled jaws firmly grip out to very tip of nose. Tempered steel with polished finish faces. Handles are palm-fitting design with red vinyl non-slip cushion grips.

Catalog Number	Length in. (mm)	Net Wt. oz. (g)
LNC6G	6-3/4 (171)	4-1/2 (128)
LNC7G	7-3/4 (197)	5-1/2 (155)

Lineman's Side Cutters



LSC7G



LSC8G

Precision pliers are rugged design with powerful leverage for pulling and cutting heavy wires. Carefully matched cutting edges and milled gripping surface are specially hardened and tempered for long life. Forged from high quality alloy steel. Polished faces. Comfort designed handles with red vinyl cushion grips.

Catalog Number	Length in. (mm)	Net Wt. oz. (g)
LSC7G	7-1/2 (191)	10-1/2 (298)
LSC8G	8-1/2 (216)	14-1/2 (411)

New England Style



LSC9G

High leverage plier is designed for cutting number 8 and other large wires. Forged from high quality alloy steel. Precision matched cutting edges are induction hardened. Jaw rivet is offset for increased leverage. Built-in insulation crusher. Red vinyl cushion grips.

Catalog Number	Length in. (mm)	Net Wt. oz. (g)
LSC9G	9-1/2 (241)	20 (577)

Diagonal Cutters



DC6G



DC7G

Powerful leverage short nose is designed to cut flush from side without obstructing handle grip. Absence of flat gripping surface on jaws allows tool to cut out to very tip. (Diagonal cutters are the only tools capable of reaching into an electrical box to cut wires). Smooth functioning box joint insures accurate alignment of cutting edges. Forged from high quality alloy steel. Hardened and tempered for long life. Polished faces. Red vinyl cushion grips.

Catalog Number	Length in. (mm)	Net Wt. oz. (g)
DC6G	7-1/4 (184)	5 (142)
DC7G	8-1/4 (210)	8 (227)

RELATED ITEMS

More Pliers & Wrenches

See CREWLINE Supplement SL10650

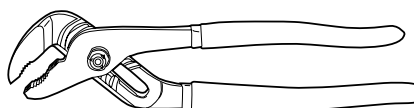
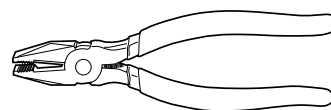
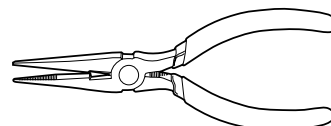



Electrical Plier

UP FRONT CRIMPING ACTION

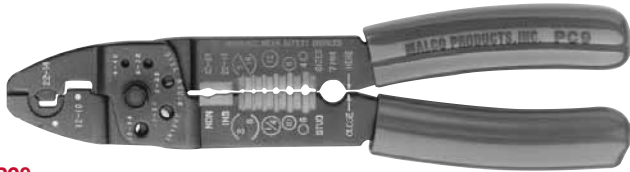

PC9

Insulated and uninsulated terminal and splice crimper with wire cutter up front. Crimps insulated terminal sizes 12-10 (yellow) and 22-14 (red and blue). Tool also crimps uninsulated terminals 22-10 and 7-8 mm auto ignition terminals. Cuts bolts with perfect rethread and features six wire stripping stations for 22-10 ga. Constructed of induction hardened alloy steel. Pivot joint is made of hardened steel lifetime bushing. Black oxide oil finish with paint markings to highlight crimping functions. Red vinyl grips are comfortable, three pocket air cushion type.

Catalog Number	Capacities		Crimping	Stripping	Length	Net Wt.
	Bolt	Cutting				
PC9	4-40	8-32	22-10 ga.	22-10 ga.	8-3/4"	7 oz.
	6-32	10-32				
		10-24				

Electrical Plier

CUTTER/STRIPPER/CRIMPER



WSC8

Up front scissors action strips copper wire clean and easily cuts sizes 10 thru 20. Bolt cutters leave a perfect rethread. Plier nose features serrated jaw and slim profile for pulling and putting loops on wire. Crimps all insulated and non-insulated solderless terminals including 7-8 mm auto. Lifetime pivot point assures greater joint strength and adds easy, precise adjustment capability. Black oxide, satin finish steel. Extra large red vinyl cushion grips.

Catalog Number	Capacities		Crimping	Stripping	Length	Net Wt.
	Bolt	Cutting				
WSC8	4-40	8-32	22-10 ga.	22-10 ga.	8-1/4"	8 oz.
	5-40	10-32				
	6-32	10-24				

Cutter/Stripper

COMBINATION AWG-METRIC



WSC1S

Automatic spring opening increases speed of stripping operation. Convenient lock protects precision cutting surfaces when not in use.

Catalog Number	Capacities AWG	Metric	Length	Net Wt.
			in. (mm)	oz. (g)
WSC1S	20-10 ga.	.5-5.3 mm	6 (152)	4 (113)

Multi-Track Pliers



MT12

MT10

MT7

Multiple slip joint pliers are ideal for use on conduit, pipe and cable connections. Tongue and groove joints hold jaws securely in selected position and take strain off bolt. Teeth are designed to give maximum grip on any round, square or hex shaped object. Long cushion grip handles give powerful leverage with gentle angled spread for easy one hand operation. Thin design permits access to confined spaces where conventional pipe wrenches won't go. Tempered steel halves offer long dependable service.

Catalog Number	Size in. (mm)	Square Opening in. (mm)	Tracks	Net Wt. oz. (g)
MT7	7 (.78)	1-1/4 (32)	5	6 (170)
MT10	10 (254)	1-1/2 (38)	5	12 (340)
MT12	12 (305)	2-3/8 (60)	7	26 (737)

Pipe Wrench Plier



MTP10

90° Offset Jaws offer 20% more leverage.

Reach where other pliers will not go. Jaws feature pipe wrench style teeth and are offset 90° to create 20% more leverage than conventional 32° angled jaws. Machined tongue and groove eliminates wear and strain on bolt. And a special handle stop prevents pliers from pinching fingers. Satin chrome finish with comfortable vinyl cushion grips.

Catalog Number	Length in. (mm)	Net Wt. oz. (g)
MTP10	10 (254)	12 (340)

PLIERS & WRENCHES



X-TRA CAPACITY

Adjustable Wrenches



Greater jaw capacity than standard adjustables, these wrenches often eliminate the need to use the next larger size. Ideal for jobs where convenience of a smaller, lighter weight wrench is desired.

Slim, tapered jaws are induction hardened to prevent disfiguring of opening. Malco wrenches are drop-forged from high quality alloy steel, heat treated and nickel chrome plated. Finished with bright head faces and satin finished handles.

Gripped Wrenches

Catalog Number	Length in. (mm)	Jaw Opening in. (mm)	Net Wt. oz. (g)
AW4G	4 (102)	1/2 (13)	1-1/2 (43)
AW6XG	6 (152)	15/16 (24)	4 (113)
AW8XG	8 (203)	1-1/8 (29)	7-1/2 (212)
AW10XG	10 (254)	1-5/16 (33)	13-1/2 (383)
AW12XG	12 (305)	1-1/2 (38)	24 (680)

Ungripped Wrenches

AW6	6 (152)	15/16 (24)	4 (113)
AW8	8 (203)	1-1/8 (29)	7-1/2 (212)
AW10	10 (254)	1-5/16 (33)	13-1/2 (383)
AW12	12 (305)	1-1/2 (38)	24 (680)

RELATED ITEMS

More Pliers & Wrenches

See **CREWLINE**
Supplement **SL10650**



REFRIGERATION

Ratchet Wrenches

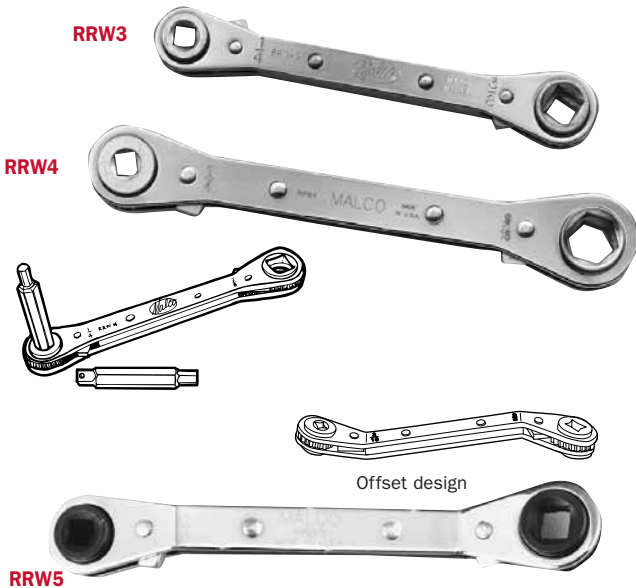

For installing or servicing heating, air conditioning or refrigeration units.

Catalog Number	Square	Hex in.
RRW4	3/16" & 1/4"	1/2" & 9/16"
RRW3	3/16", 1/4", 5/16" & 3/8"	
RRW5	3/16", 1/4", 5/16" & 3/8"	

5/16" & 3/16" HEX KEY WRENCH INSERTS

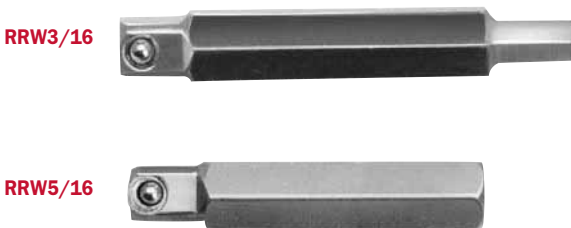

1/4" square drive shanks fit Malco RRW3 and RRW4 Ratchet Wrenches. Facilitates easy ratcheting action for servicing hard to access valves common in air conditioning and refrigeration condensing units. 1-5/8 inches long.

Catalog Number	Square Shank Dia.	Hex Key Dia.	O/A Lgth.
RRW5/16	1/4"	5/16"	1-5/8"
*RRW3/16	1/4"	3/16"	1-5/8"

*RRW3/16 Hex Stock Measures 5/16"

"T" Handle Hex Keys

Finest quality nickel-chrome alloy steel. Precision tempered. Easy to grasp loop handle may be hung up. Available in 6" and 9" lengths. Key sizes stamped on top of handles. Black oxide finish.

6" length Catalog Number	9" length Catalog Number	Width Across Flats	Handle Width
WT6 1/8	WT9 1/8	1/8"	3"
WT6 5/32	WT9 5/32	5/32"	3"
WT6 3/16	WT9 3/16	3/16"	4"

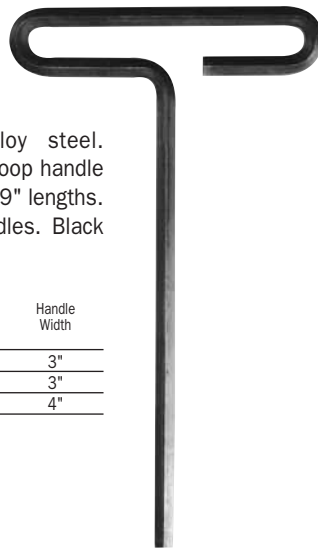

"T" Handle Hex Key Sets in Plastic Pouch

WT6S
8 PC. SET
6" Length



WT9S
8 PC. SET
9" Length



Catalog Number	Description
WT6S	6" long, eight "T" handle hex keys (3/32-1/4").
WT9S	9" long, eight "T" handle hex keys (3/32-1/4").

"L" Hex Keys

REFRIGERATION LENGTHS

Available in 6" and 12" long series. Tough alloy steel, black oxide finish. In reusable vinyl pouch.

W6
9 PC. SET
6" Length



W12
7 PC. SET
Big 12" Length

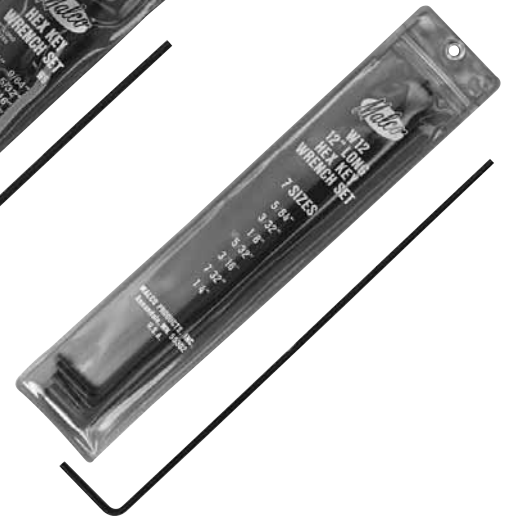

"L" Hex Key Sets in Plastic Pouch

Catalog Number	Length	Number of sizes
W6	6"	9 sizes: 5/64, 3/32, 7/64, 1/8, 9/64, 5/32, 3/16, 7/32 and 1/4"
W12	12"	7 sizes: 5/64, 3/32, 1/8, 5/32, 3/16, 7/32 and 1/4"

"L" Hex Key - Individual Sizes

6 INCH LONG		12 INCH LONG	
Catalog Number	Description	Catalog Number	Description
W6 5/32	5/32"	W1218	1/8"
		W12532	5/32"

HEX KEYS



Ball Tip L-Wrench Sets

EASY SOCKET
ACCESS AT ANGLES
UP TO 25° OFF-AXIS



Wrench Sets
store in Handy
reusable case.



WBL7S
7 PIECE SET

Tough alloy steel. Black oxide finish.

TWO TOOLS IN ONE Standard hex end for maximum torque. Ball end for angles.



WBL12S
12 PIECE
SET



WBL7S
7 PIECE
SET



PROFESSIONAL QUALITY
Folding Hex Key Sets
PRODUCED FROM
TOUGH ALLOY STEEL

Hex Corners of keys are sharp and clean. Finish is black oxide.



Smooth nickel plated case can be used as handle for extra leverage. Flat spring holds keys in any work position.

Catalog Number	W19	W29	W45	W48
Description	SMALL POCKET	DELUXE POCKET	LARGE SIZES	EXTRA LONG
Handle Lgth.	3-5/8"	4-1/4"	5-1/4"	5-1/4"
No. of Keys	9	9	5	8
HEX SIZES - WIDTH ACROSS FLATS				
<p>Flat spring in case holds keys in any work position</p>	.050"	-	-	-
	1/16"	-	-	-
	5/64"	5/64"	-	-
	3/32"	3/32"	-	3/32"
	7/64"	7/64"	-	7/64"
	1/8"	1/8"	-	1/8"
	9/64"	9/64"	-	9/64"
	5/32"	5/32"	-	5/32"
	3/16"	3/16"	3/16"	3/16"
	-	7/32"	7/32"	7/32"
	-	1/4"	1/4"	1/4"
	-	-	5/16"	-
-	-	3/8"	-	



Regular Grip Screwdrivers

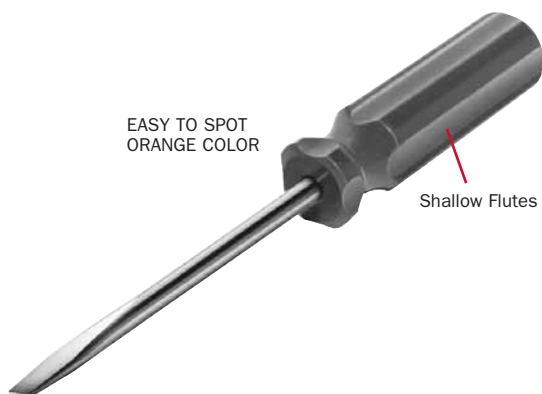

Precision Ground tip for perfect screw fit.

Cushion Grip Screwdrivers

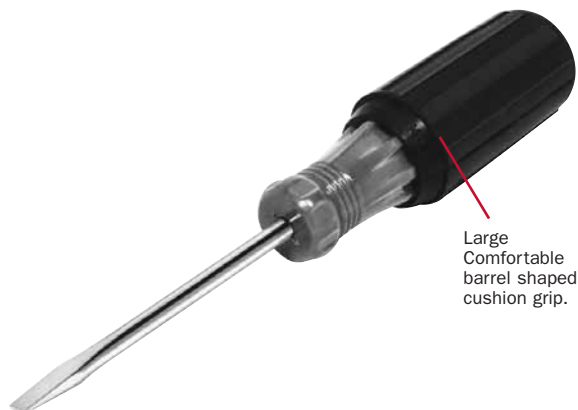

Designed for maintenance, electrical and assembly continuous use applications. Keystone and Phillips drivers are also ideal for driving hardened screw heads in sheet metal. Individually heat treated blade tips are precision ground for perfect fit in screw head. Handles are shockproof and shatterproof. Driver handles and blades are joined securely and will not turn or come loose. Driver construction assures many years of reliable, superior performance.

REGULAR GRIP SCREWDRIVERS

Shallow fluted handles with large end bearing surface provide a sure, comfortable grip for maximum torque.

CUSHION GRIP SCREWDRIVERS

The same great features as all Malco drivers plus a large, comfortable barrel shaped cushion grip.

SQUARE SHANK KEYSTONE

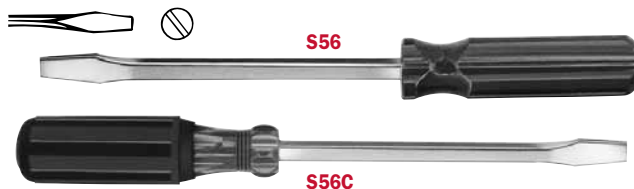

Catalog Number	Regular Grip	Cushion Grip	Blade Dia.	Blade Length	Recom. Screw#
S44		S44C	1/4"	4"	10-12
S56		S56C	5/16"	6"	12-16
S68		S68C	3/8"	8"	16-20
S612		S612C	3/8"	12"	16-20

ROUND SHANK KEYSTONE

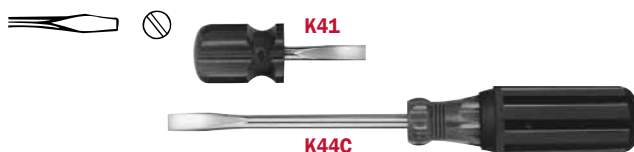

Catalog Number	Regular Grip	Cushion Grip	Blade Dia.	Blade Length	Recom. Screw#
K41		K41C	1/4"	1-1/2"	10-12
K44		K44C	1/4"	4"	10-12
K56		K56C	5/16"	6"	12-16
K68		K68C	3/8"	8"	16-20

ELECTRICAL/CABINET STYLE



Catalog Number	Regular Grip	Cushion Grip	Blade Dia.	Blade Length	Recom. Screw#
C22		—	1/8"	2"	2-5
C33		C33C	3/16"	3"	6-9
C36		C36C	3/16"	6"	6-9
—		C45C	1/4"	5"	10-12
—		C48C	1/4"	8"	10-12

ELECTRICAL STYLE

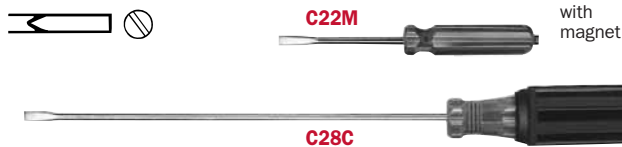

Catalog Number	Regular Grip	Cushion Grip	Blade Dia.	Blade Length	Recom. Screw#
C22M		—	1/8"	2"	2-5
C24		C24C	1/8"	4"	2-5
—		C26C	1/8"	6"	2-5
—		C28C	1/8"	8"	2-5

SCREWDRIVERS



PHILLIPS HEAD High Polish Finish

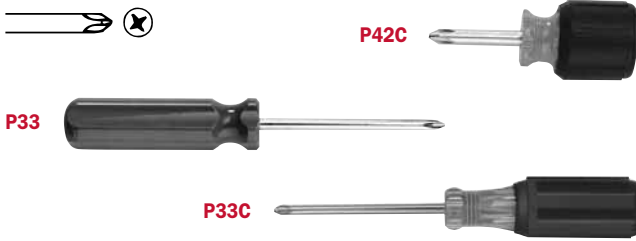

Catalog Number	Regular Grip	Cushion Grip	Blade Dia.	Blade Length	Recom. Screw#
P33		P33C	3/16"	3"	No. 1
		P42C	1/4"	1-1/2"	No. 2
P44		P44C	1/4"	4"	No. 2
P56		P56C	5/16"	6"	No. 3

7 PIECE COMBINATION Screwdriver Sets



SK20



Most popular sizes of Keystone, cabinet style and Phillips screwdrivers packaged in a vinyl see-thru pouch.

REGULAR GRIP SET

CUSHION GRIP SET

Catalog Number	Description	Catalog Number	Description
K41	Round Shank Keystone	K41C	Round Shank Keystone
K44	Round Shank Keystone	K44C	Round Shank Keystone
K56	Round Shank Keystone	K56C	Round Shank Keystone
C22	Electrical/Cabinet Style	C24C	Electrical Style
C33	Electrical/Cabinet Style	C33C	Electrical/Cabinet Style
P33	Phillips Head	P33C	Phillips Head
P44	Phillips Head	P44C	Phillips Head

Catalog Number	Description
SK20	Regular grip 7 piece driver set
SK2C	Cushion grip 7 piece driver set

6 in 1 Reversible Driver

COMBINATION BITS CHANGE TO DRIVE 6 DIFFERENT HEAD STYLES OR SIZES.

1/4" & 5/16 Hex opening nut driver with 3/16" & 9/32" Slotted Head bit and #1 & #2 Phillips Head bit.

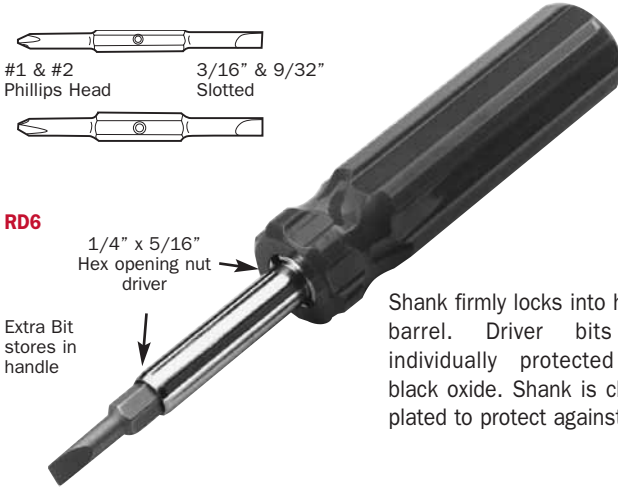

Catalog Number	Description
RD6	Driver with 2 replaceable bits
10550	Replacement bit for 3/16" & 9/32" slotted head screws
10551	Replacement bit for #1 & #2 phillips head screws

RELATED ITEMS

More Screwdrivers & Nut Drivers

See CREWLINE Supplement SL10650

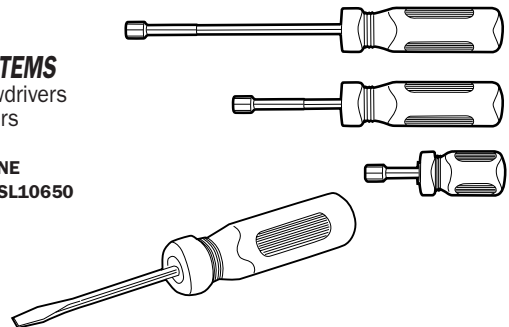



Standard Nut Drivers with FULL HOLLOW SHAFT

Malco Nut Drivers feature steel shafts with precision cold drawn and case hardened nose sockets. Nickel chrome finish resists elements. Comfortable fluted handles are color coded by size and feature a larger diameter and end bearing surface for maximum torque.

Standard and Extra Long Nut Driver sizes are also available in 7 PIECE SETS packaged in a vinyl plastic pouch.

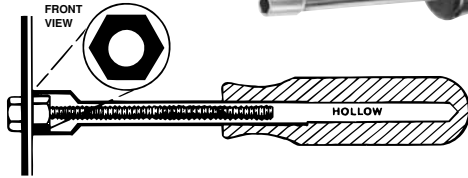

Hollow shafts (see illustration) make these nut drivers more versatile for a variety of jobs requiring nut setting.

Catalog Number	Hex Opening	Shank Dia.	Shank Lgth.	Hole Depth.	Nose Dia.	Handle Color	O/A Lgth.
ND6	3/16"	1/4"	3-1/8"	5-1/2"	3/8"	black	6-1/4"
ND8	1/4"	5/16"	3-1/8"	6"	7/16"	red	7-1/4"
ND10	5/16"	5/16"	3-1/8"	6"	1/2"	amber	7-1/4"
ND11	11/32"	5/16"	3-1/8"	6"	9/16"	green	7-1/4"
ND12	3/8"	3/8"	3-1/8"	6"	9/16"	blue	7-1/4"
ND14	7/16"	7/16"	3-1/8"	6"	5/8"	amber	7-1/4"
ND16	1/2"	7/16"	3-1/8"	6"	11/16"	red	7-1/4"

STANDARD NUT DRIVER KIT

ND7K Drivers ND6, ND8, ND10, ND11, ND12, ND14 and ND16

Extra Long Nut Drivers WITH FULL HOLLOW SHAFT



Extra long for extra reach.

Catalog Number	Hex Opening	Shank Dia.	Shank Lgth.	Hole Depth.	Nose Dia.	Handle Color	O/A Lgth.
ND8L	1/4"	5/16"	6"	9-3/4"	7/16"	red	9-1/8"
ND10L	5/16"	5/16"	6"	9-3/4"	1/2"	amber	10-1/8"
ND12L	3/8"	3/8"	6"	10"	9/16"	blue	10-1/8"

EXTRA LONG NUT DRIVER KIT

NDL7K Drivers ND6L, ND8L, ND10L, ND11L, ND12L, ND14L and ND16L

MAGNETIC Hex Drivers

Use with Zip-in® and Type "A" hex head screws.

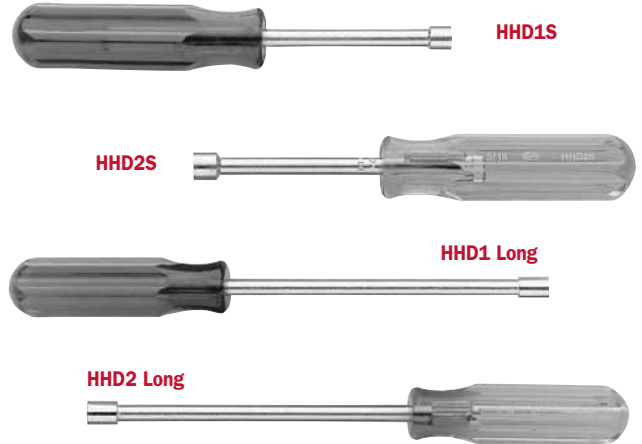

STANDARD LENGTHS

Catalog Number	Hex Opening	Shank Dia.	Nose Dia.	Handle Color	O/A Lgth.
HDD1S	1/4"	1/4"	3/8"	red	7-1/4"
HDD2S	5/16"	1/4"	7/16"	amber	7-1/4"

LONG DRIVERS

Catalog Number	Hex Opening	Shank Dia.	Nose Dia.	Handle Color	O/A Lgth.
HDD1	1/4"	5/16"	7/16"	red	10-1/8"
HDD2	5/16"	5/16"	1/2"	amber	10-1/8"

Stubby Nut Drivers



For working in confined areas. Make small work of big jobs with three sizes.

Catalog Number	Hex Opening	Shank Dia.	Shank Lgth.	Hole Depth.	Nose Dia.	Handle Color	O/A Lgth.
ND8S	1/4"	1/4"	1-1/4"	1-1/4"	7/16"	red	3-1/4"
ND10S	5/16"	1/4"	1-1/4"	1-1/4"	1/2"	amber	3-1/4"
ND12S	3/8"	1/4"	1-1/4"	1-1/4"	9/16"	blue	3-1/4"

POWER DRIVERS



1/4" HEX SHANK Power Bits

MBLP4



PHILLIPS POWER BITS

Catalog Number	Point Size	Shank Dia.	O/A Length
MBLP2	3	1/4"	1-15/16"
MBLP3	2	1/4"	1-15/16"
MBLP4	2	1/4"	2-3/4"



MAGNETIC HEX DRIVERS

Catalog Number	Hex Opening	Shank Dia.	Nose Dia.	O/A Length
MSH1/4	1/4"	1/4"	7/16"	1-3/4"
MSH5/16	5/16"	1/4"	1/2"	1-3/4"
MSH3/8	3/8"	1/4"	9/16"	1-3/4"



LONG STYLE

MSHL1/4	1/4"	1/4"	7/16"	2-9/16"
MSHL5/16	5/16"	1/4"	1/2"	2-9/16"
MSHL3/8	3/8"	1/4"	9/16"	2-9/16"
MSHL7/16	7/16"	1/4"	11/16"	2-9/16"



EXTRA LONG STYLE

MSHML1/4	1/4"	1/4"	7/16"	4"
MSHXL1/4	1/4"	1/4"	7/16"	6"
MSHML5/16	5/16"	1/4"	1/2"	4"
MSHXL5/16	5/16"	1/4"	1/2"	6"

Power Bit Extensions

BHE10



BHE6

Ball Bearing Lock Big 6" and 10" lengths

Accepts 1/4" hex power bits. Ball Bearing on holder provides a positive lock on 1/4" hex shank power bits. Tempered steel.

Catalog Number	Hex Opening	Shank Dia.	Nose Dia.	O/A Length
BHE6	1/4"	1/4"	9/16"	6"
BHE10	1/4"	1/4"	9/16"	10"

QUICK CHANGE Hex adapter

HAD1



Accepts 1/4" hex power bits. Installs into chuck of a standard 3/8" power drill. Hex power bits can then be inserted or removed instantly without a key, by retracting the adapter sleeve. Tempered steel. Black finish.

Catalog Number	Hex Opening	Shank Dia.	Bore Depth	Sleeve Dia.	O/A Length
HAD1	1/4"	3/8"	7/8"	7/8"	1-3/4"

PHILLIPS INSERT



Catalog Number	Point Size	Shank Dia.	O/A Length
MBSP2	2	1/4"	1"

MAGNETIC BIT HOLDER

For 1/4" Hex Shank Insert Bits



Catalog Number	Hex Opening	Shank Dia.	Nose Dia.	O/A Length
MBH1/4	1/4"	1/4"	7/16"	3"



Wood Bits

SPADE TYPE



Unique designed ground points and cutting edges drill faster, cleaner holes, using less power than standard spade type bits. Cut straight or angled holes in soft and hard woods, plus formica, plaster, chipboard, foam core material, many non-metallic building sidings and foam insulation. Made of one-piece special heat treated tool grade steel. Six "flat" 1/4" shank fits securely in conventional chucks. Easy to spot "size marking" is stamped on head. Bits also feature "head hole" for convenient storage and wire pulling. Resharpener with saw file or grinder. Available individually or in sets. 12" extension also available. See below.

Catalog Number	Diam.
WB38	3/8"
WB12	1/2"
WB58	5/8"
WB34	3/4"
WB78	7/8"
WB1	1"
WB118	1-1/8"
WB114	1-1/4"
WB138	1-3/8"
WB112	1-1/2"



WB6K

WOOD BIT KIT

Catalog Number	Description
WB6K	6 piece set: 3/8", 1/2", 5/8", 3/4", 7/8" and 1"

WOOD BIT EXTENSION



WBEX

Catalog Number	Diam.	Overall Lgth.	Shank Dia.
WBEX	—	12-7/8"	1/4"

Step Drills

A unique double flute design assures the penetration of soft or thin materials at the proper speed. Drill hole sizes from 1/8" to 1" in sheet metal without burring or deforming stock or threading drill bit. Malco Step Drills actually deburr as they drill. Perfect for use as a "hole-opening" reamer. They can also be used for making round holes from slots or intersecting holes. Made of industrial grade high speed steel. Malco Step Drills are heat treated and tempered to assure maximum strength for long wearing rugged use. Completely resharpenable.

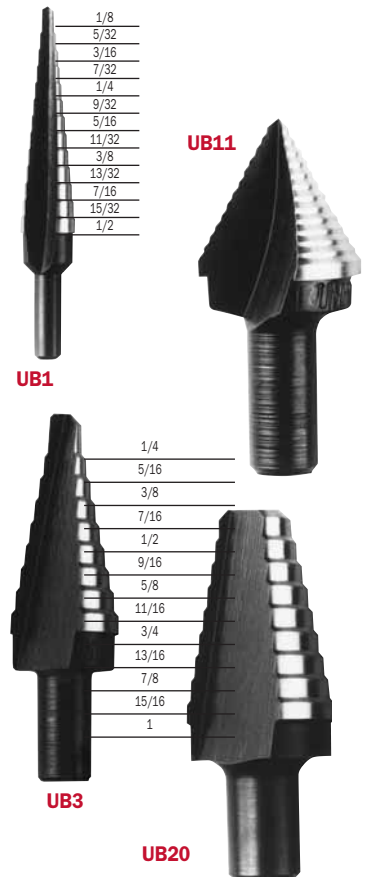

Catalog Number	Description in. (mm)	Depth Each Step	Elect. Drill Size	Pilot Hole Req.
UB1	Drills 13 hole sizes from 1/8" to 1/2" diameter in 1/32" (0.79) increments.	1/8"	1/4"	No
UB20	Drills 8 hole sizes from 9/16" to 1" diameter in 1/16" increments.	1/8"	1/2"	1/2"
UB3	Drills 9 hole sizes from 1/4" to 3/4" diameter in 1/16" increments.	1/8"	3/8"	No
UB11	Drills single hole size 7/8" diameter for creating 1/2" knock outs.	N/A	3/8"	No

CARBIDE TIPPED

Rotary-Percussion Bits



Use in any rotary or rotary percussion drilling device for unexcelled performance in brick, tile, granite, concrete, masonry and other similar hard and dense materials. Brazed tungsten carbide tips have 120° chamfer and are specially tempered for strength and long life. Drill body is black oxide finish.

Catalog Number	Bit Dia.	Shank Dia.	Nominal O/A Lgth.
RP01	1/8"	1/8"	3"
RP04	3/16"	3/16"	3-1/2"
RP09	1/4"	1/4"	4-1/4"
RP10	1/4"	1/4"	6"
RP18	5/16"	5/16"	4-1/2"
RP31	3/8"	1/4"	6"
RP46	1/2"	3/8"	6-3/4"

DRILL BITS



Jobber Drill Sets

13 PIECE SET

Catalog Number Description
FJ13S
 Fractional sizes in metal DRILDEX container. Sizes: 1/16 to 1/4" x 64ths.



15 PIECE SET

Catalog Number Description
FJ15S
 Fractional sizes in metal DRILDEX container. Sizes: 1/16 to 1/2" x 32nds.



29 PIECE SET

Catalog Number Description
FJ29S
 Fractional sizes in metal DRILDEX container. Sizes: 1/16 to 1/2" x 64ths.

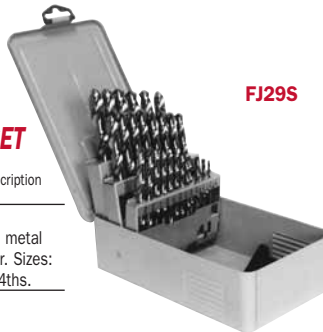

60 PIECE SET WIRE GAUGE

Catalog Number Description
FJ60S
 Wire gauge sizes in metal DRILDEX container. Sizes: 1 to 60.

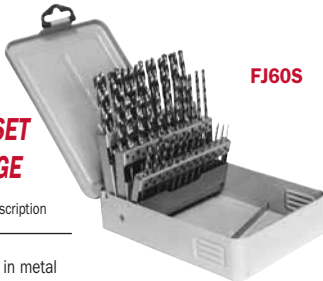

20 PIECE ORIFICE DRILL SET

FJ6180
 includes PV1 Pin Vise

Catalog Number Description
FJ6180
 Wire gauges sizes for drilling or cleaning oil and gas orifices. Metal DRILDEX container. Sizes: 61 to 80. Includes pin vise.



HIGH SPEED Jobber Length Drills

General purpose drills. 118° conventional point angle allows deep drilling in a variety of materials including metal.

FRACTIONAL SIZES

Catalog Number	Decimal Equiv. Inches	Length Overall Inches
FJ1/8	.1250	2-3/4
FJ3/16	.1875	3-1/2
FJ1/4	.2500	4
FJ5/16	.3125	4-1/2
FJ3/8	.3750	5
FJ7/16	.4375	5-1/2
FJ1/2	.5000	6

Sheet Metal Drills

Sheet metal drills with 135° split point design bite into metal precisely where wanted - will not wander.

FRACTIONAL SIZES

Catalog Number	Decimal Equiv. Inches	Length Overall Inches	Pkg. Size
FS1/8	.1250	1-7/8	1
FS3/16	.1875	2-3/16	1
FS1/4	.2500	2-1/2	1

FS Series with 1/4" reduced shank

FS5/16	.3125	2-13/16	1
FS3/8	.3750	3-1/8	1
FS1/2	.5000	3-3/4	1

WIRE GAUGE SIZES

FS29	.1360	1-15/16	1
-------------	-------	---------	---

POLISHED DRILLS

PFS1/8	.1250	1-7/8	12
PFS30	.1285	1-15/16	12
PFS1/4	.2500	2-1/2	12

BLACK NITRIDED DRILLS

NFS1/8	.1250	1-7/8	12
NFS30	.1285	1-15/16	12

Pin Vise

PV1



Use in hand or insert in drill chuck. Pin Vise holds wire gauge drill sizes 60 to 97.

Catalog Number	Capacity	Length
PV1	Gauge sizes 60-97	3"

DOUBLE ENDER Sheet Metal Drills



TWO POINTS FOR TWICE THE LIFE, TWICE THE CONVENIENCE

Polished Drills

Catalog Number	Decimal Equiv. Inches	Length Overall Inches	Length of twist Inches	Pkg. Size
DE1/8	.1250	2	1/2	12
DE30	.1285	2	1/2	12
DE9/64	.1406	1-15/16	1/2	12
DE3/16	.1875	2-3/16	1/2	12
DE1/4	.2500	2-1/2	1/2	12



DE1/8B

Double Enders in Bulk Boxes

Catalog Number	Description	Pkg. Size
DE1/8B	Bulk Double Enders	144
DE30B	Bulk Double Enders	144

Black Nitrided Drills

Catalog Number	Decimal Equiv. Inches	Length Overall Inches	Length of twist Inches	Pkg. Size
NDE1/8	.1250	2	1/2	12
NDE30	.1285	2	1/2	12



1/8" (3.18 mm)

Ceiling Grid Punch



Work overhead and in tight corners



Malco's unique, new Ceiling Grid Punch makes a clean 1/8 inch hole in up to three layers of 25 gauge ceiling grid. The tool's slim but strong steel "C" frame allows easy access in tight corners and is ideal for punching through main tees and perimeter wall angle that is to be secured with rivets. A generous throat opening allows full operation from the edge of both standard 1 in. and 1/2 in. grid profiles. The Malco Ceiling Grid Punch features durable all steel construction and rust resistant nickel plate and black oxide finishes; the 1/8 in. tool steel punch is easily replaceable. Lightweight, one hand operation, aided by compound leverage, helps assure a consistent professional quality installation. Tool also features non-slip vinyl grips with hand stops for added comfort and resistance to elements.

Catalog Number	Punch in. (mm)	Overall Length in. (mm)	Net Wt. oz. (g)
CGP	1/8 (3.18)	9 (229)	19 (539)
CGP18	Replacement Punch 1/8"		

CAPACITIES

Material:	Aluminum	Copper	Stainless Steel	Galvanized Sheet Metal
Inches (mm)	n/a	n/a	n/a	.026 (0.66) up to 3 layers

TOOL SPECIFICATIONS

Punch / Frame	Variable Leverage Ratio High/Low Throughout Stroke
Tool Steel Punch w/ Alloy Steel Frame	6.7 to 1.0 - 8.4 to 1.0

1/8" - 3/16" (3.18 - 4.76 mm)

Hole Punch

ADJUSTS FROM 1/4" TO 1-1/8" (6 to 29 mm) DEPTHS

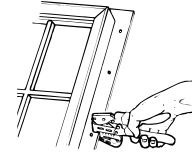

HP18K

Maximum capacity (2 layers) 24 gauge.

Compound Handle Leverage for maximum ease of operation.

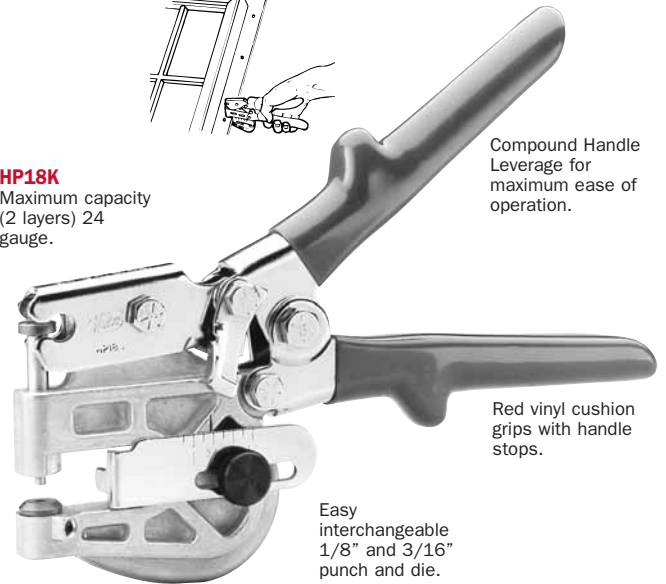

Red vinyl cushion grips with handle stops.

Easy interchangeable 1/8" and 3/16" punch and die.

Does the work of more expensive bulkier punches faster and easier. Work overhead to pre-punch rivet holes in suspended ceiling grids or use in any edge application for making holes in window extrusions, metal ductwork or sheet stock. Compound leverage increases one hand mechanical advantage 8 to 1. Spring return handles allow quick set-up for repetitive applications. Stop gauge permits adjustments from 1/4" to 1-1/8" increments. Punch and die are easily replaceable or changed from standard 1/8" hole size to 3/16". Punch and dies are constructed from high quality tool steel used in commercial high production punch press dies. Body of tool consists of lightweight, aluminum die cast 'C' frame and rust resistant nickel plated steel handles and parts. Tool also features non-slip vinyl grips with hand stops for added comfort and resistance to elements. Compact enough to fit in any tool box or pouch.

Catalog Number	Punches in. (mm)	Capacity (Sheet Metal)	Net Wt. oz. (g)
HP18K	1/8 (3.18)	Max. (2) layers	16 (454)
	3/16 (4.76)	24 gauge	

PUNCH AND DIE SETS

HPD18	1/8" Replacement Punch & Die Kit
HPD316	3/16" Replacement Punch & Die Kit
HPD36M	3.6 mm Replacement Punch & Die Kit
HPD41M	4.1 mm Replacement Punch & Die Kit
HPD63M	6.3 mm Replacement Punch & Die Kit

CAPACITIES

Material:	Aluminum	Copper	Stainless Steel	Galvanized Sheet Metal
Inches (mm)	n/a	n/a	n/a	.029 (0.74) up to 2 layers

TOOL SPECIFICATIONS

Punch / Frame	Variable Leverage Ratio High/Low Throughout Stroke
Tool steel Punch w/Die Cast Zinc Frame	6.7 to 1.0 - 8.4 to 1.0

HAND RIVETERS: Blind Rivets



2-in-1 Hand Riveter

2 IN 1

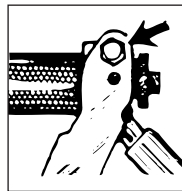

LONG STROKE
Bolt in upper hole for easy pulling rivets in one pull

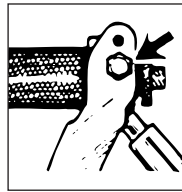

SHORT "RATCHET ACTION" POWER STROKE
Bolt in lower hole for hard pulling rivets in several easy pulls

One hand operation with normal squeezing action provides enough pulling power to set all popular size rivets (see spec. columns below). 2-in-1 adjustment features a single long stroke for most hand riveting applications and a short "ratchet action" power stroke for setting larger diameter rivets. Outside jaw-grip adjustment wheel opens and closes jaws with fingertip ease to fit any size mandrel and to obtain maximum stroke efficiency. Professional slim nose allows 2-in-1 to go where other hand riveters cannot. Ideal for reaching into corners and recessed areas. Three nosepieces 1/8, 5/32 and 3/16" included with tool. Nosepieces are stored in handle. Heavy duty all steel construction insures long life and minimum wear. Polished finish, nickel-chrome plated. Red vinyl cushion grip and hand stop.

Catalog Number	Capacity in. (mm)	Length in. (mm)	Net Wt. oz. (g)
2-in-1	1/8 thru- 3/16 (3.18 - 4.76) rivet w/steel mandrel	8 (203)	20 (567)
	1/8 thru- 5/32 (3.18 - 3.97*) rivet w/stainless steel mandrel		

2-in-1 KIT

Catalog Number	Description
2-in-1K	Riveter with carrying case.

ACCESSORIES & PARTS

Catalog Number	Description
ER41	Jaws for 2 in 1
ER44	3/16" nosepiece for 2 in 1
ER45	1/8" nosepiece for 2 in 1
ER46	5/32" nosepiece for 2 in 1
HR3-7	Adjustment rod assembly for 2 in 1
1667	7 compartment kit box



ECONOMY Hand Riveter

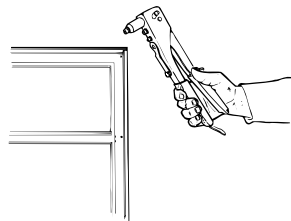

CR18



Lightweight, compact size and slim nose projection allows this riveter to go wherever the work is. Four rivet nosepieces: 3/32, 1/8, 5/32, 3/16" store in handle. Ideally suited for blind riveting applications in aluminum windows, gutter and downspout. **Not for use with 5/32" or 3/16" steel rivets.** Spring return handles and comfortable contour grip make operation fast and easy. Just open handles and insert rivet into tool until flange touches nosepiece. Squeeze handles slightly to allow jaws to grip rivet mandrel. Insert rivet into pre-drilled work to be fastened and squeeze handles until mandrel snaps. Release grip on handles and mandrel will drop out front end of tool when tilted.

Rugged steel construction with black paint finish and comfortable vinyl grip. Secure handle latch makes this tool easy to fit in pouch or pocket.

Catalog Number	Description in. (mm)	Length in. (mm)	Net Wt. oz. (g)
CR18	3/32 thru 3/16 (2.38 - 4.76) aluminum capacity	8 (203)	22 (624)



Rivet Washers

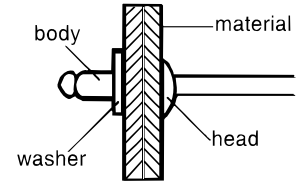
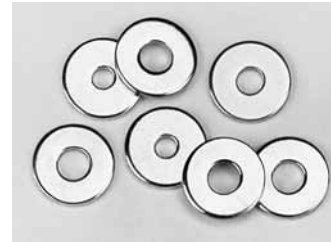

Back up washers for riveting in soft materials. Non-blind applications only. Install washer on rivet head protruding through backside of material to be fastened. Washers are zinc plated steel.

Catalog Number	Size in. (mm)	I.D. in. (mm)	O.D. in. (mm)	Thickness in. (mm)
4RW	1/8 (3.18)	.130 (3.30)	.500 (12.70)	.0478 (1.21)
5RW	5/32 (3.98)	.160 (4.06)	.500 (12.70)	.0478 (1.21)
6RW	3/16 (4.75)	.191 (4.85)	.500 (12.70)	.0478 (1.21)

Blind Rivets

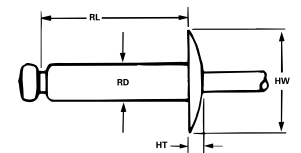
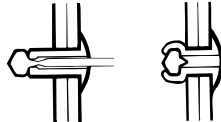

Rivet Dia.	Steel Rivet Coated Steel Mandrel	Steel Rivet Plated Steel Mandrel	Aluminum Rivet Aluminum Mandrel	Aluminum Rivet Plated Steel Mandrel	Stainless Rivet Stainless Mandrel	Copper Rivet Plated Steel Mandrel	Hole Size # Drill No.	RL=Rivet Body Length RD=Rivet Body Diam. HW=Rivet Head Width HT=Rivet Head Thickness	RL	RD	HW	HT	Grip Range
1/8"	SS42DJ	SS42D	AA42D	AS42D	SS/SS42D	CS42D		.232	.125	.250	.032	.063-.125	
1/8"		SS43D	AA43D					.294	.125	.250	.032	.126-.187	
1/8"	SS44DJ	SS44D	AA44D	AS44D	SS/SS44D	CS44D		.357	.125	.250	.032	.188-.250	
1/8"		SS46D	AA46D		SS/SS46D			.481	.125	.250	.032	.313-.375	
1/8"			AA48D		SS/SS48D		.128-.132	.606	.125	.250	.032	.376-.500	
Drill #30													
1/8"		SS42DW	AA42DW **					.232	.125	.250	.032	.063-.125	
1/8"		SS44DW	AA44DW **					.357	.125	.250	.032	.188-.250	
3/16"		SS62D						.277	.187	.375	.047	.020-.125	
3/16"		SS64D	AA64D				.192-.196	.402	.187	.375	.047	.188-.250	
3/16"		SS66D					Drill #11	.527	.187	.375	.047	.251-.375	

NOTE: Package sizes available in handy boxes, tubs or bulks. Consult your Malco Suggested Trade Prices for specific package quantities available for each size. Count on Malco for full, accurate piece counts in every fastener pack you buy.

Painted Rivets**

DW = White



OTHER PAINTED RIVETS IN STOCK

AA42DW	=	White
AA42DRB	=	Royal Brown
AA42DMB	=	Musket Bronze
AA42DCC	=	Classic Cream
AA44DMB	=	Musket Bronze
AA44DRB	=	Royal Brown

Painted Rivets packaged in 100 piece bags.

Rivet Mandrel	Rivet Dia.	Minimum Lbs. Shear/Tensile	
Steel Rivet Steel Mandrel	1/8"	260	310
	3/16"	540	680
Aluminum Rivet Aluminum Mandrel	1/8"	120	150
	3/16"	260	320
Aluminum Rivet Steel Mandrel	1/8"	120	150
	3/16"	260	320
Stainless Rivet Either Mandrel	1/8"	420	530
	3/16"	950	1200
Copper Rivet Steel Mandrel			
	1/8"	350	450

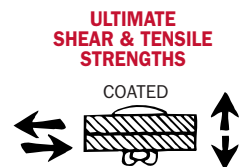



FASTENERS: Self Drilling Screws

Zip-in® Screws

Catalog Number	Head Size
HW6x3/8Z	1/4"
* HW7x1/2Z	1/4"
* HW8x1/2Z	1/4"
* HW8x3/4Z	1/4"
* HW8x1Z	1/4"
* HW8x1-1/2Z	1/4"
* HW8x2Z	1/4"
HW10x1/2Z	1/4"
HW10x3/4Z	1/4"
HW10x1Z	1/4"



NOTE: Package sizes available in handy boxes, tubs, bulks and NEW PAILS!

* Denotes screw sizes available in pails.

Consult Malco Suggested Trade Prices for specific package quantities available for each screw size. **Count on Malco for full, accurate piece counts in every ZIP-IN package you buy.**

Zip-in® White Painted Screws

HW8x1-1/2ZW	1/4"
HW8x2ZW	1/4"

Zip-in® REGISTER SCREWS White Painted Phillips Oval Head

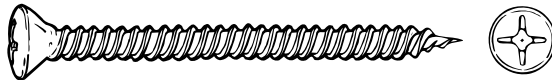

Catalog Number	Color	Point Size
PO8x2ZW	White	#2

Zip-in® Kit

HWZ1K



Contains five Zip-in® sizes plus an MSH1/4 hex chuck driver. Ideal for maintenance applications. Packaged in compact refillable plastic case.

Catalog Number	Description
HWZ1K	Plastic case containing one MSH1/4 and 100 each HW7x1/2Z, HW8x1/2Z, HW8x3/4Z, HW10x1/2Z and HW10x3/4Z.

Painted Sheet Metal Screws

RB = Royal Brown	W = White
MB = Musket Bronze	CC = Classic Cream
A = Almond	CL = Clay

Catalog Number	Head Size
HW6x3/8ZA	1/4"
HW6x3/8ZCC	1/4"
HW6x3/8ZCL	1/4"
HW6x3/8ZMB	1/4"
HW6x3/8ZRB	1/4"
HW6x3/8ZW	1/4"
HW7x1/2ZA	1/4"
HW7x1/2ZCC	1/4"
HW7x1/2ZCL	1/4"
HW7x1/2ZMB	1/4"
HW7x1/2ZRB	1/4"
HW7x1/2ZW	1/4"
HW7x1ZCL	1/4"
HW8x1ZRB	1/4"
HW8x1ZW	1/4"
HW8x3/4ZRB	1/4"
HW8x3/4ZW	1/4"

Packaged in bags.



Drill-in Screws

Type A, Single Thread

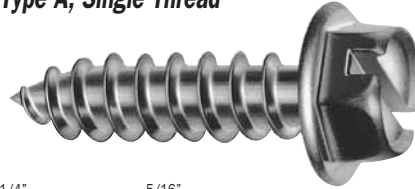

1/4" HEAD SIZE Catalog No.	5/16" HEAD SIZE Catalog No.
HW8x3/4	HW10x1-1/4
HW8x1-1/4	HW10x1-1/2
HW8x1-1/2	HW10x2
HW8x2	HW12x1
	HW12x1-1/2
	HW12x2

STAINLESS STEEL DRILL-IN SCREWS

Catalog No.
HW8x1/2SS

FASTENERS: Anchors

Red Lip Plastic Anchors

Use with wood, sheet metal or lag screws. Flexible anchor is ideal for masonry or stone. Lip on collar prevents anchor from pushing through hole in hollow walls.

Catalog Number	Anchor Size	For Screw Size(s)	Uses Bit Dia.
PA810	3/16" x 7/8"	8-9-10	3/16"
PA1012	1/4" x 1"	10-12	1/4"
PA1416	5/16" x 1-3/8"	14-16	5/16"



RED LIP ANCHOR KITS

All kits contain equal quantities of anchors and screws with one matching carbide tipped drill bit.



Kits with slotted pan head screws

Catalog Number	Anchor Size	Screw Size(s)	Uses Bit Dia.	Anchor Kit Quantity
PA810K	3/16" x 7/8"	SP8x1	3/16"	100
PA1012K	1/4" x 1"	SP10x1-1/4	1/4"	100
PA1416K	5/16" x 1-3/8"	SP14x1-1/2	5/16"	50

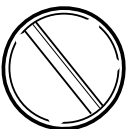

Kits with hex washer head screws

PA810KW	3/16" x 7/8"	HW8x1Z	3/16"	100
PA1012KW	1/4" x 1"	HW10x1Z	1/4"	100





FASTENERS: Self Drilling Screws

Zip-in® Screws

Catalog Number	Head Size
HW6x3/8Z	1/4"
* HW7x1/2Z	1/4"
* HW8x1/2Z	1/4"
* HW8x3/4Z	1/4"
* HW8x1Z	1/4"
* HW8x1-1/2Z	1/4"
* HW8x2Z	1/4"
HW10x1/2Z	1/4"
HW10x3/4Z	1/4"
HW10x1Z	1/4"



NOTE: Package sizes available in handy boxes, tubs, bulks and NEW PAILS!

* Denotes screw sizes available in pails.

Consult Malco Suggested Trade Prices for specific package quantities available for each screw size. **Count on Malco for full, accurate piece counts in every ZIP-IN package you buy.**

Zip-in® White Painted Screws

HW8x1-1/2ZW	1/4"
HW8x2ZW	1/4"

Zip-in® REGISTER SCREWS White Painted Phillips Oval Head

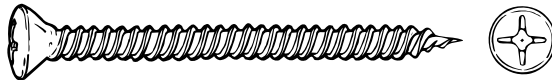

Catalog Number	Color	Point Size
PO8x2ZW	White	#2

Zip-in® Kit

HWZ1K



Contains five Zip-in® sizes plus an MSH1/4 hex chuck driver. Ideal for maintenance applications. Packaged in compact refillable plastic case.

Catalog Number	Description
HWZ1K	Plastic case containing one MSH1/4 and 100 each HW7x1/2Z, HW8x1/2Z, HW8x3/4Z, HW10x1/2Z and HW10x3/4Z.

Painted Sheet Metal Screws

RB = Royal Brown	W = White
MB = Musket Bronze	CC = Classic Cream
A = Almond	CL = Clay

Catalog Number	Head Size
HW6x3/8ZA	1/4"
HW6x3/8ZCC	1/4"
HW6x3/8ZCL	1/4"
HW6x3/8ZMB	1/4"
HW6x3/8ZRB	1/4"
HW6x3/8ZW	1/4"
HW7x1/2ZA	1/4"
HW7x1/2ZCC	1/4"
HW7x1/2ZCL	1/4"
HW7x1/2ZMB	1/4"
HW7x1/2ZRB	1/4"
HW7x1/2ZW	1/4"
HW7x1ZCL	1/4"
HW8x1ZRB	1/4"
HW8x1ZW	1/4"
HW8x3/4ZRB	1/4"
HW8x3/4ZW	1/4"

Packaged in bags.



Drill-in Screws

Type A, Single Thread

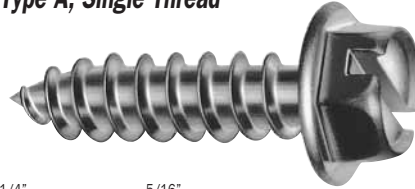

1/4" HEAD SIZE Catalog No.	5/16" HEAD SIZE Catalog No.
HW8x3/4	HW10x1-1/4
HW8x1-1/4	HW10x1-1/2
HW8x1-1/2	HW10x2
HW8x2	HW12x1
	HW12x1-1/2
	HW12x2

STAINLESS STEEL DRILL-IN SCREWS

Catalog No.
HW8x1/2SS

FASTENERS: Anchors

Red Lip Plastic Anchors

Use with wood, sheet metal or lag screws. Flexible anchor is ideal for masonry or stone. Lip on collar prevents anchor from pushing through hole in hollow walls.

Catalog Number	Anchor Size	For Screw Size(s)	Uses Bit Dia.
PA810	3/16" x 7/8"	8-9-10	3/16"
PA1012	1/4" x 1"	10-12	1/4"
PA1416	5/16" x 1-3/8"	14-16	5/16"



RED LIP ANCHOR KITS

All kits contain equal quantities of anchors and screws with one matching carbide tipped drill bit.



Kits with slotted pan head screws

Catalog Number	Anchor Size	Screw Size(s)	Uses Bit Dia.	Anchor Kit Quantity
PA810K	3/16" x 7/8"	SP8x1	3/16"	100
PA1012K	1/4" x 1"	SP10x1-1/4	1/4"	100
PA1416K	5/16" x 1-3/8"	SP14x1-1/2	5/16"	50

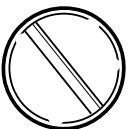

Kits with hex washer head screws

PA810KW	3/16" x 7/8"	HW8x1Z	3/16"	100
PA1012KW	1/4" x 1"	HW10x1Z	1/4"	100



BIT-TIP®

Drill & Tap Screws

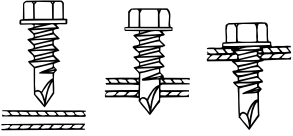

BIT-TIP®

drills its own hole, taps a matching thread and fastens in steel up to .220 thick in less time than it takes to drill a pilot hole for other standard fasteners.



THE ONE OPERATION FASTENER WITH THE TRUE DRILLING ACTION POINT!

By drilling its own hole, Bit-Tip® produces the optimum hole size, resulting in better thread engagement and a tighter fit. One operation fastening also means no alignment problems.

Bit-Tip® has a wide range of industry applications. Select the Bit-Tip® that's right for the job. Point length will determine metal thickness that can be drilled, tapped and fastened. Also, plywood, soft wood, composition board, drywall, insulation and laminates may be fastened to metal framing or components.

Made from strong, high quality, specially heat treated steel. Bit-Tip® Self Drilling and Tapping Screws are precision cold forged insuring uniformity of dimension and drill point contours.

The versatile Bit-Tip® Screw is an excellent replacement for fastening operations now using rivets, nuts and bolts, spot welds or adhesives. Bit-Tip® also eliminates the need for costly auxiliary fastening equipment such as drill bits, taps and welding equipment.

Requires only a standard screw gun power tool rated at 2500 RPM equipped with drilling depth locator.



TOP VIEW

HEAD TYPE CONFIGURATION



HEX WASHER



SLOTTED HEX WASHER



BONDED SEALING HEX WASHER

INDUSTRIAL APPLICATIONS

Sheet Metal

STRUCTURAL

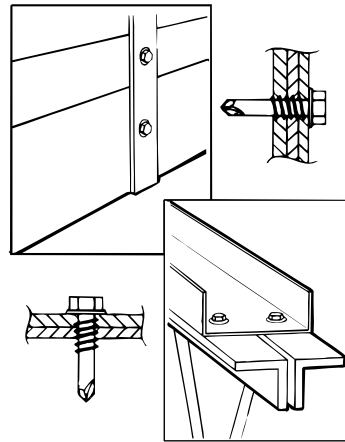

Metal Building

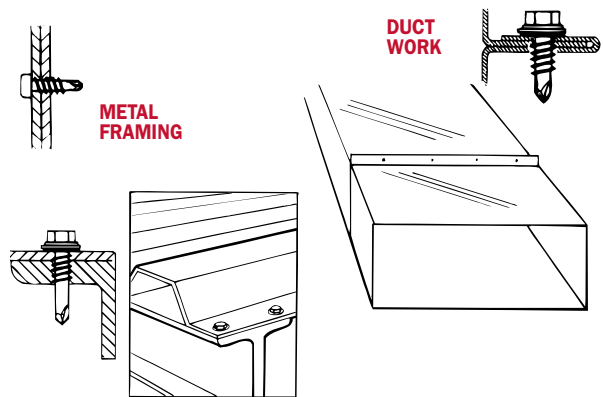

SHEET TO STRUCTURE

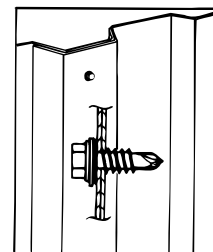



BIT-TIP®

SCREW SELECTION

NOTE: Package sizes available in handy boxes, tubs or bulks. Consult your Malco Suggested Trade Prices for specific package quantities available for each size. **Count on Malco for full, accurate piece counts in every BIT-TIP pack you buy.**

Material thickness recommendation for Bit-Tips®

For This Material Thickness			
.050	.100	.150	.200

Catalog Number	Head Type	Screw Size	Driver Size
----------------	-----------	------------	-------------

HEX WASHER, SLOTTED HEX WASHER BIT-TIP®

BIT-TIP SCREW #2 POINT	BT131	HW	8-18x1/2	1/4	
	BT132	HW	8-18x5/8	1/4	
	BT133	HW	8-18x3/4	1/4	
	BT134	HW	8-18x1	1/4	
	BT231	HS	8-18x1/2	1/4	
	BT233	HS	8-18x3/4	1/4	
	BT234	HS	8-18x1	1/4	
	BT141	HW	10-16x1/2	5/16	
#3	BT142	HW	10-16x5/8	5/16	
	BT143	HW	10-16x3/4	5/16	
	BT144	HW	10-16x1	5/16	
	BT145	HW	10-16x1-1/4	5/16	
	BT153	HW	10-24x3/4	5/16	
	BT154	HW	10-24x1	5/16	
	BT156	HW	10-24x1-1/2	5/16	
#3	BT163	HW	12-14x3/4	5/16	
	BT164	HW	12-14x1	5/16	
	BT166	HW	12-14x1-1/2	5/16	
	BT174	HW	1/4-14x1	3/8	

BONDED SEALING TYPE HEX WASHER HEAD (ZINC PLATED) BIT-TIP®

#3	BT464	HB	12-14x1	5/16	
	BT466	HB	12-14x1-1/2	5/16	
	BT474	HB	1/4-14x1	3/8	

Ultimate Bit-Tip® Screw Strengths

Test results furnished are given purely as a guide and do not constitute a warranty of any type. Results may vary by modification to the fastener or in certain applications.

Thread Size	Point Size	Pull-out values (lbs.) in common steel gauges.											Torsional Strength (lbs.)	Strength (lbs.)		
		26	24	22	20	18	16	14	13	1/8	10	3/16				
6	20	#2	141	208	268	331	513	633	874						1125	24
8	18	#2	150	187	289	334	507	643	977						1575	42
10	16	#2	145	235	295	364	572	708	1,015	1,972					2100	61
	24	#3								1,528	2,120	2,199			2350	65
12	14	#3								1,541	1,990	2,650	3,515	2800	92	
14	14	#3								1,504	1,818	2,413	3,190	3850	150	
	20	#3								1,788	2,330	2,830	4,420	4275	168	

Tool Pouches



TP1
BOX TYPE
Molded

Description / Nominal Dimensions

BOX TYPE TOOL POUCH: Strap leather. 4 large gusseted utility pockets. 2 molded front plier pockets, 2 driver pockets, hammer loop and small tool snap. 9" x 10" (229 x 254 mm).



TP80
Comes with
Fastener Pouch

Description / Nominal Dimensions

TRADE TOOL POUCH WITH CLIP-ON FASTENER POUCH SUPPLIED: Two large inside pockets, back wall slots for 3 drivers, 2 generous front pockets easily accommodate aviation snips or snap lock size hand tools. Pouch also features outside hammer loop, open end driver slot, 2 riveted clips for tape measure and fastener pouch (supplied), swinging chain "T" bar for large tape rolls, and wide tunnel belt loop. 8-1/2" x 10" (216 x 254 mm).

Our Most Popular Leather Pouch

TP3 ELECTRICIANS
Heavy chrome tanned,
brushed leather

**NINE COMPARTMENT
ELECTRICIAN'S POUCH:**

Heavy chrome tanned, brushed leather, 2 large flared inside pockets with center divider, back wall slots for 3 drivers, 3 flared deep front pockets, 2 outside open end driver slots, swing chain "T" bar for friction tape and riveted harness snap for small tool or knife. Holster for steel tape (12' x 3/4" capacity), outside hammer loop and wide tunnel belt loop. Our most popular leather pouch! 8-1/2" x 10" (216 x 254 mm).



TP81
Fastener Pouch



FASTENER POUCH: 4-5 oz., chrome tanned, suede split leather with Velcro closure, clips to belt or tape measure clip. 4-1/2" x 5-1/2" (114 x 140 mm).



TPB1
WEB BELT
Army spec. hardware.

WEB BELT: 2-1/4" (57 mm) wide heavy webbing. U.S. Army spec. hardware. Adjustable up to 46" (1168 mm) waist.



TPB3
DELUXE LEATHER BELT
Double tongued roller
buckle.

DELUXE LEATHER BELT: Distinctive 2" (51 mm) wide saddle leather belt. Double tongue roller buckle. One size fits all, cut off to desired length from 30" to 46" (762 to 1168 mm).



TPB4
1-3/4" WIDE
LEATHER BELT

HEAVY DUTY 1-3/4" (45 mm) WIDE LEATHER BELT: Distinctive tooled 9-10 oz. saddle leather. Heavy roller buckle and leather keeper. One size fits all, cut off to desired length from 30" to 46" (762 to 1168 mm).



TP5

TWO BAG APRON: Supple moccasin (ball glove) and saddle leather construction.

Description / Nominal Dimensions

CONSTRUCTION WORKER'S TWO BAG APRON: Durable 5-6 oz. golden tan, supple ball glove leather. 2 large nail pockets, 2 outside finishing nail pockets, 2 small tool pockets, 4 slots for punch or pencil, knife or plier holster and holster for steel tape (25' x 1" capacity), leather hammer loop on each side, double lock stitched and rivet reinforced. U.S.Army spec. 2-1/4" (57 mm) web belt. Our No. 2 best seller. 9-3/4" x 10-1/4" (248 x 260 mm).

TP67

NAIL AND TOOL BAG:
Moccasin

5-POCKET NAIL BAG AND TOOL POUCH: Heavy 5-1/2 oz. ball glove leather. Large bellows flared main pocket, ample outside pocket for fasteners, 2 small tool pocket and 4 punch size pockets. Double stitched and rivet reinforced. Wide tunnel loop fits web belt. Leather hammer loops on right and left side. 9" x 11-1/2" (229 x 292 mm)



TP12

TWO BAG APRON: Suede (split leather) and saddle leather construction. The look of top grain moccasin without the price.

TWO BAG SUEDE APRON: Heavy duty golden tan suede and saddle leather construction, rivet reinforced, 2 large pockets, 2 front pockets, 4 small tool pockets, 25' tape pocket, right and left hammer loops, combination square loop, 4 small tool holders, 2-1/4" (57 mm) belt with nickel plated hardware adjusts to 48" (1219 mm) waist size. 9-1/4" x 9-1/4" (235 x 235 mm).



TP18
UTILITY KNIFE
SHEATH



TP21
PLIER HOLSTER
Molded



TP201
SNIP HOLSTER Fits all Andy™
and Navi-Gator™ snips.



TP301
KNIFE SHEATH Fits Malco
DK1 Duct Knife



TP25
HAMMER LOOP



TP33
TAPE RULE
HOLDER

Catalog Number	Description / Nominal Dimensions
TP18	UTILITY KNIFE SHEATH: Fiber lined, closed end sheath fits Malco 3PK and 4PK knives and all other major brand utility knives. Heavy-duty, top grain saddle leather. 5-1/2" x 1-1/2" (140 X 38 mm) fiber lined, tunnel pocket with closed bottom to resist cutting. Rivet reinforced pocket for extra strength. Extra wide 2-3/4" (70 mm) belt slots. 3-1/4" x 5-1/2" (83 x 140 mm)
TP21	MOLDED PLIER HOLSTER: Top grain saddle leather. Tunnel loop fits web belt. 2-1/2" x 8" (64 x 203 mm).
TP25	STEEL LOOP HAMMER HOLDER: 2 x 2" (51 x 51 mm) riveted steel wire loop. Heavyweight strap leather. Wide belt slots. 4-1/2" x 8" (114 x 203 mm).
TP33	STEEL TAPE RULE HOLDER: 25' x 1" capacity. Saddle leather pre-formed pocket. Belt slots fit wide web belt. 3-1/2" x 4-1/2" (89 x 114 mm).

Catalog Number	Description / Nominal Dimensions
TP201	SNIP HOLSTER: Fits all Malco Aluminum Snips. Saddle leather. Double stitched and rivet reinforced. Wide tunnel loop. 14" x 4" (356 x 102 mm).
TP301	KNIFE SHEATH: Fits Malco DK1 duct knife Heavy top grain saddle leather. Double stitched and rivet reinforced. Wide tunnel loop fits web belt. 10" x 2-3/4" (254 x 70 mm).

TP45
CORDLESS DRILL
HOLSTER

"Quick Draw" 45° Angle!

TP45	CORDLESS DRILL HOLSTER: Top grain saddle leather, rivet reinforced, large mouth, 45° opening for easy removal & drop-in access, fits medium to large cordless drills, wide loop for 2-1/2" (64 mm) belt. 7-3/4" x 13-1/2" (197 x 343 mm).
-------------	--



TP601
FLEX DUCT CUTTER
SHEATH

Tailor made for the Malco FDC1 Flex Duct Cutter and FDC2 Flex Duct Shear. The TP601 Sheath is constructed of heavy, top grain saddle leather - double stitched and rivet reinforced.



Catalog Number	Description	Length in. (mm)
TP601	Leather Sheath for FDC1	13-1/2 (343)



TPA1
TEN
POCKET APRON

Description / Nominal Dimensions

TEN POCKET WAIST APRON: Double tier pockets feature 2 large flared nail pockets. 1 small nail center pocket, 4 tool pockets and 3 nail-center punch pockets. Duck canvas is reinforced with heavy duty stitching. Nylon hammer loops on right and left sides. 10-1/4" x 22-3/4" (260 x 578 mm).



TPA3
LARGE
POCKET
APRON

LARGE POCKET WAIST APRON: Two large 7" x 8" (178 x 203 mm) flared nail pockets offer large capacity and easy hand access. Nylon hammer loop will not bind against hammer handle. Apron also features two small side pockets for tools. Made of 9-10 oz. duck canvas. Completely bound. 8-1/2" x 21" (216 x 533 mm).



TPA4
SHOP
APRON

Description / Nominal Dimensions

BLUE DENIM SHOP APRON: Below knee length apron has 2 large pockets and slot at waist, swing pocket and pencil pocket at chest level. Criss-cross over the shoulder straps with grommets at waist. Double stitched throughout. 37" x 26" (940 x 660 mm).



TPA5
SIX POCKET
BIB APRON

6 POCKET BIB APRON: 10 oz. duck canvas. Large bib pocket and pencil sheath, 2 large nail pockets at waist and 2 small tool side pockets. Reinforced with heavy duty stitching. Nylon hammer loop. 18-1/2" x 22-1/4" (470 x 565 mm).



TP63
CANVAS TOOL BAG
Roomy, soft sided bag is a versatile carrier for any tool shape or bulky load.

CANVAS TOOL BAG: 8-10 oz. duck canvas bag is built around a light, strong, 12 gauge steel frame. Large 9" x 11" (229 x 279 mm) inside tool pocket. Leather handles and straps with buckle closure. Sturdy masonite bottom features metal studs. Vinyl reinforcement covers entire bottom and extends three inches up each side. 20" x 6" x 15" (508 x 152 x 318 mm).

POUCHES: Knee Pads



TPKP3
SOFTCAP: Ideal for roofers!

CONTOURED KNEE PADS
Foam padded to hug the knees and covered with tough DuPont CORDURA®

Catalog Number Description / Nominal Dimensions

TPKP3 **CORDURA® KNEE PADS - SOFTCAP:** Non-slip, grip work surface to prevent sliding. Long thick cap improves weight distribution, and wider elastic straps hold pads more securely. Thicker foam cushioning and adjustable closures provide added comfort. Natural color cap is non-marring.

TPKP4
PROFESSIONAL KNEE PADS
Cellular rubber.



TPKP8
ECONOMY KNEE PADS
Foam Rubber

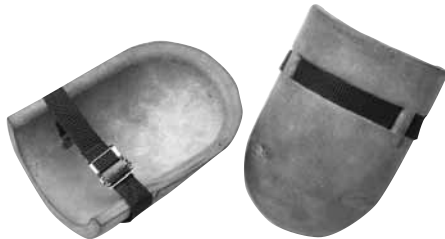

Catalog Number Description / Nominal Dimensions

TPKP4 **PROFESSIONAL KNEE PADS:** Two adjustable, 3/4" (19 mm) wide, polypropylene straps per pad for a secure, comfortable fit. Thick water repellent cellular rubber for maximum wearing comfort.

TPKP8 **ECONOMY KNEE PADS:** Foam rubber pads for maximum wearing comfort. 3/4" (19 mm) adjustable polypropylene strap per pad for secure, comfortable fit.

TPKP2
HARD CAP
CONTOURED KNEE PADS



Catalog Number Description / Nominal Dimensions

TPKP2 **CORDURA® KNEE PADS - HARDCAP:** General purpose, offer superior protection and body weight distribution so user can swivel and slide freely on working surface. Contoured 1/2" (13 mm) foam padding and adjustable closures provide added comfort and mobility.

Metal Tool Box

Boxes are heavy gauge steel with baked-on enamel finish. Strong comfortable grip carrying handle will withstand years of daily use.

Popular size with single compartment in tote tray. Oversized positive catch draw bolts with padlock eyes.



1602

Catalog Number	Nominal Dimensions (L - W - H) in. (mm)	Net oz. (g)
1602	18 x 8 x 9 (457 x 203 x 229)	9.5 (4.31)

RUST PROOF Plastic Tool Boxes

1671



1672

Large capacity tool boxes are lightweight yet durable polypropylene construction. Rust proof polypropylene also resists grease and most solvents. Boxes are fully lockable with polished steel drawbolts and removable tray.

Catalog Number	Nominal Dimensions (L-W-H) in. (mm)	Net Wt. lbs (kg)
1671	16-3/4 x 8 x 7-1/2 (426 x 203 x 191) w/tray	3.44 (1.56)
1672	20 x 9-1/2 x 9 (508 x 241 x 229) w/tray	4.81 (2.18)

Tote Tray



1660

These heavy duty, crush proof tote trays are great for carrying hand tools and fasteners to the job site. Rust proof polypropylene body material is long wearing, lightweight and portable. Three roomy compartments to accommodate all the tools you need. Comfortable hand grip rolls to outside - will not bit into palm of hand. Model 1660, tote box only.

Catalog Number	Nominal Dimensions (L-W-H) in. (mm)	Net Wt. lbs (kg)
1660	15 x 10 x 4-1/2 (381 x 254 x 114)	1.75 (0.79)

Utility Boxes



1666



1667

1666 Six compartment box with snap latch lid.

1667 One compartment. Crush proof polypropylene with living hinge and secure snap latch lid.

Catalog Number	Nominal Dimensions (L-W-H) in. (mm)	Net Wt. oz. (g)
1666	10-1/4 x 4-5/8 x 1-3/8 (260 x 118 x 35)	8 (227)
1667	10-5/8 x 6-1/2 x 1-3/4 (270 x 165 x 45)	14 (397)

Extension Lights

GROUNDING STEEL GUARD

High visibility orange thermoplastic PVC cord jacket. Grounded swing-open steel guard. Handle has on-off push-thru switch and one grounded side outlet. For lamps up to 75 watts.

Catalog Number	Wire # & Gauge Insulation Type	Feet	Amps - Volts
EL3025	16/3 SJT	25	13A - 125V
EL3050	16/3 SJT	50	13A - 125V

MEETS OSHA REQUIREMENTS

Cross Section



Actual Size

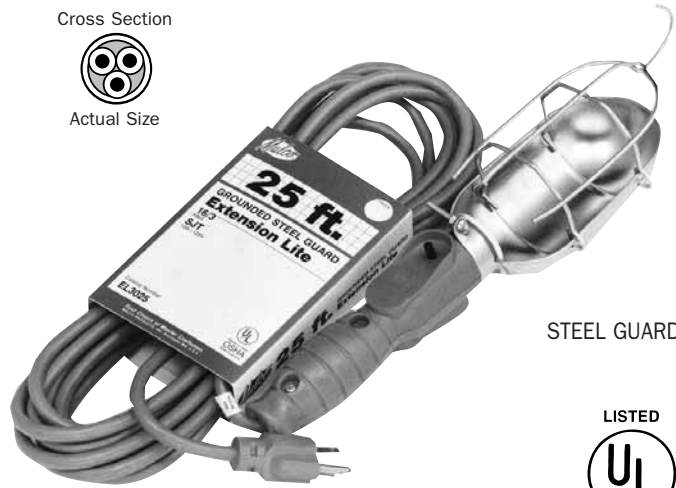

STEEL GUARD

LISTED



ALL WEATHER LIGHT with Grounded Steel Guard

TPR elastomer cord jacket stays flexible to in extreme cold down to -70°C . Cord is bright safety yellow. Grounded steel guard is swing-open type. Handle has on-off, push-thru switch and one side outlet. Encapsulating injection molding securely bonds all handle parts and cord to handle. For lamps up to 75 watts.

Catalog Number	Wire # & Gauge Insulation Type	Feet	Amps - Volts
EL3B25	16/3 SJEO	25	13A - 125V

MEETS OSHA REQUIREMENTS

Cross Section



Actual Size



STEEL GUARD

LISTED



Clamp-on Reflector Light

TPR elastomer cord jacket is flexible in cold. 8-1/2" aluminum reflector. On-off, push-thru switch at base. Revolves 360°. Spring clamp and double ball joint allows light to be positioned and aimed in any direction. For lamps up to 150 watts.

Catalog Number	Wire # & Gauge Insulation Type	Feet	Amps - Volts
EROR15	18/2 SJT	15	10A - 125V

MEETS OSHA REQUIREMENTS

Cross Section



Actual Size



LISTED



LISTED



MEETS OSHA REQUIREMENTS



Outdoor Extension Cords

High visibility orange thermoplastic PVC jacket. Round cord construction. Use with portable tools, small motors, appliances and similar electric equipment.

Catalog Number	Wire # & Gauge Insulation Type	Feet	Amps - Volts	Cross Section Actual Size
EC3050	16/3 SJTW-A	50	13A - 125V	

EC5025	14/3 SJTW-A	25	15A - 125V
EC5050	14/3 SJTW-A	50	15A - 125V



MEETS OSHA REQUIREMENTS

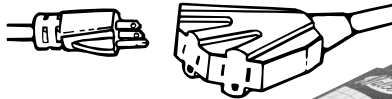

Outdoor 3-Way Power Spread

High visibility round cord with thermoplastic PVC jacket. Grounded three way power spread features unbreakable molded connectors serving as the power source for three different jobs at the same time. 3 outlets - the total capacity is limited to the indicated cable rating. Rated for hard on-the-job use.

Catalog Number	Wire # & Gauge Insulation Type	Feet	Amps - Volts	Cross Section Actual Size
EP5025	14/3 SJTW-A	25	15A - 125V	

EP902	12/3 SJE0W-A	2	15A - 125V
--------------	--------------	---	------------



LISTED



Adapters

3-WAY POWER BLOCK

Catalog Number	Description	Color	Amps - Volts
EB3TAP	3-wire tap	Black	15A - 125V

MEETS OSHA REQUIREMENTS

LISTED





NEW No. TSHD

HEAVY-DUTY TurboShear “HD” even cuts spiral duct one-handed!



CAPACITIES:

Heavy-duty jaws and gearing are suitable for cutting 18-GAUGE galvanized steel and most other common sheet metals. 20-gauge capacity in spiral duct and layered metal seams.

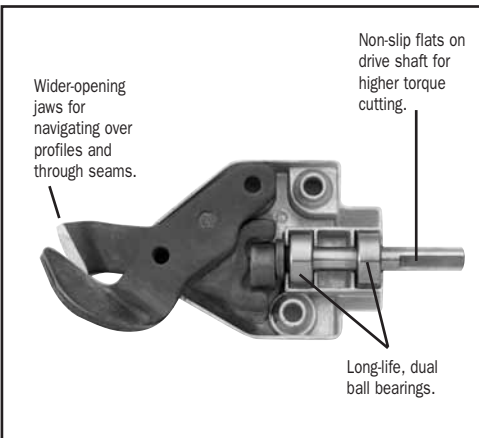

The TurboShear HD even makes angled crosscuts through profiles of metal building panels and stone coated metal shingles.



Re-position upside down as necessary for greater maneuverability.

ONE-HAND OPERATION:

- Clamping devise is standard with No. TSHD TurboShear.
- Fits most 14.4-volt or larger A/C or cordless drills.
- Cuts straight and to left.
- Capable of navigating tight curved patterns and square cuts.
- Blind cuts require a 1-inch starting hole.

Catalog Number	Description	Cap. in Galv. Steel gauge (mm)	Cap. in Spiral Duct gauge (mm)	Net Wt. oz. (kg)	Repl. Blade
TSHD	TurboShear HD	18 (1.32)	20 (1.02)	3.94 (1.79)	TSHDRB



NEW No. TSDC

DRILL CLAMP

Converts the No. TS1 TurboShear for ONE-HAND-USE!



The Malco No. TSDC Drill Clamp fits most 1200 rpm or larger cordless or A/C drills to make cutting with the TurboShear Model TS1 a one-handed operation.

Made of strong but lightweight aluminum, the rails of the TSDC Drill Clamp are easily attached to the TS1 and positioned and tightened over the body of a drill. Side-grips are also easily positioned on the rails so they do not cover drill vents.

The TSDC Drill Clamp and TS1 TurboShear combination can be repositioned upside down as required for even greater maneuverability when cutting across a large expanse of material or through mild profiles.

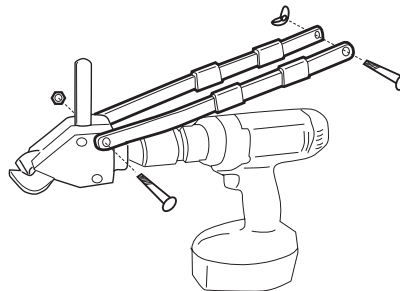

Re-position upside-down as required for greater maneuverability.

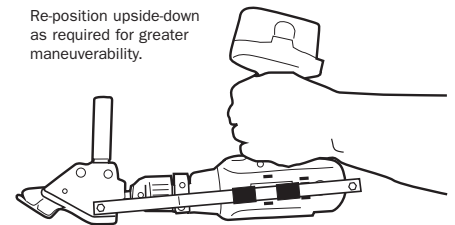

Catalog Number	Description	Net Wt. oz. (kg)
TSDC	Drill Clamp for TS1	8 (0.22)



MRER

Edge Roller



Slide tool over edge of metal and make a score by gliding tool along full length of panel.

Use repetitive motions to gently bend edge upward. Rollers at the ends of stops and a plastic pad at base of tool assure smooth, non-marring operation. Long-life bearings and a stainless steel body offer long, dependable tool life.



An English and metric depth scale is adjustable for 5/8" - 4" (15.88mm - 101.60 mm) bends.

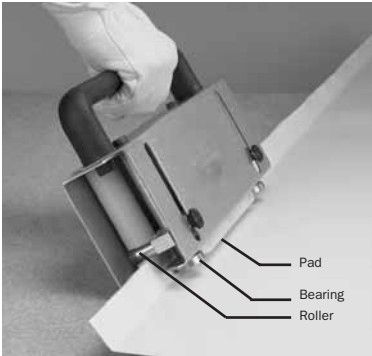

The Malco Edge Roller No. MRER makes clean precise bends along the edge of standing-seam metal roofing or metal building panels. The Edge Roller features an English/metric depth scale and is adjustable for 5/8" - 4" (15.88mm - 101.60 mm) bending depths. Easy-to-adjust thumb screws quickly lock in the stop gauges without the use of tools. Rollers at the ends of stops and a plastic pad at base of tool assure smooth non-marring operation as the tool glides along the length of a panel and gently bends the edge upward with repetitive motions. Long-life roller bearings and a stainless steel body offer long, dependable tool life.



Set the bending depth. Easy-to-adjust thumbscrews quickly lock in the stop gauges without the use of tools.

Catalog Number	Description	Bending Depth inches (mm)	Net Wt. lbs. (kg)	Replacement Pad
MRER	Edge Roller	5/8" - 4" (15.88 - 101.60)	8.5 (3.86)	MRERP

NEW
“MAGNETIC TIP”
TAPE MEASURE

Ideal for working with metal!



No. T425M

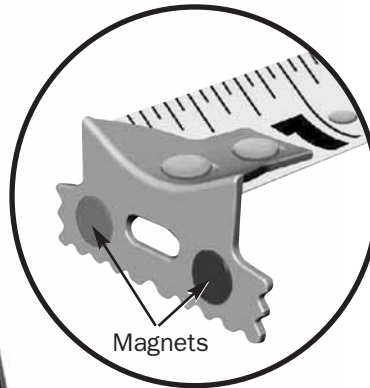
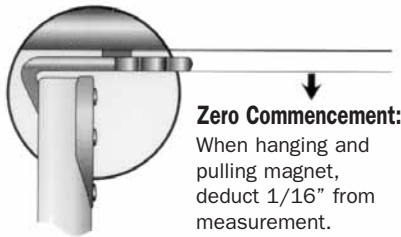

Magnetic Attraction!

At last, the obvious! Malco’s new “MAGNETIC TIP” TAPE MEASURE is ideal for every ferrous metalworking project! Use it for HVAC ductwork installations, ceiling grid applications, metal stud framing and more. A powerful magnet and self-supporting 1” X 25’ blade makes 1-person measurements and measuring elevations an easy task. The magnetic tip and big standout blade can even be used as a pick-up tool! A double riveted tip connection, abrasion-resistant, nylon coated blade and rubber-clad housing and blade stop assure lasting performance.



*The “MAGNETIC TIP” TAPE MEASURE,
another good idea from Malco!
Look for it at your nearest full line distributor.*

Catalog Number	Description	Net Wt.
T425M	1” x 25’ Magnetic Tip Tape Measure	14 oz.

CUSHIONED-GRIPPED Hex "T" Key Set



Extra long, hardened and tempered alloy steel Hex "T" Keys provide extra reach and extra leverage. Plus, vinyl cushion grips and comfort provide added torque.

- Big 6" and 9" sets consist of 8 sizes: 3/32", 7/64", 1/8", 9/64", 5/32", 3/16", 7/32" and 1/4".
- Kits are packaged in reusable, clear vinyl pouches with velcro-tab closures.
- Red vinyl grips imprinted with sizes make these keys easy to spot on the job and easy to retrieve from your tool kit or tool box.
- Rust-resistant finish on hex shafts assures long service life.
- Popular 1/8", 5/32" and 3/16" sizes are also available individually.

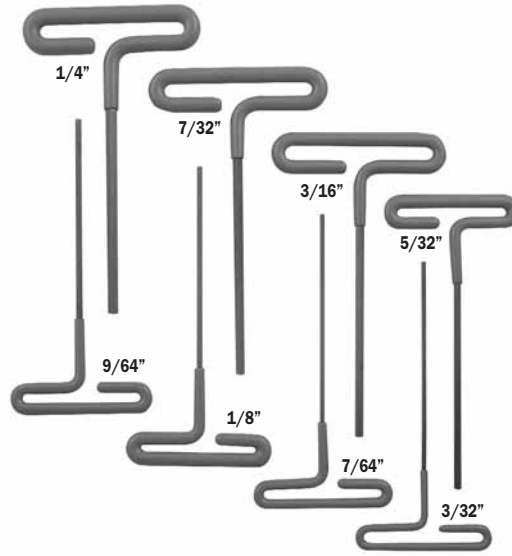

6" GRIPPED HEX "T" KEY SET

Catalog Number	Description
WT6SG	T-Handle Gripped Hex Wrench Kit 8 sizes.
INDIVIDUAL 6" LONG WRENCHES	
WT618G	1/8" T-Hex Key 6" long.
WT6532G	5/32" T-Hex Key 6" long.
WT6316G	3/16" T-Hex Key 6" long.

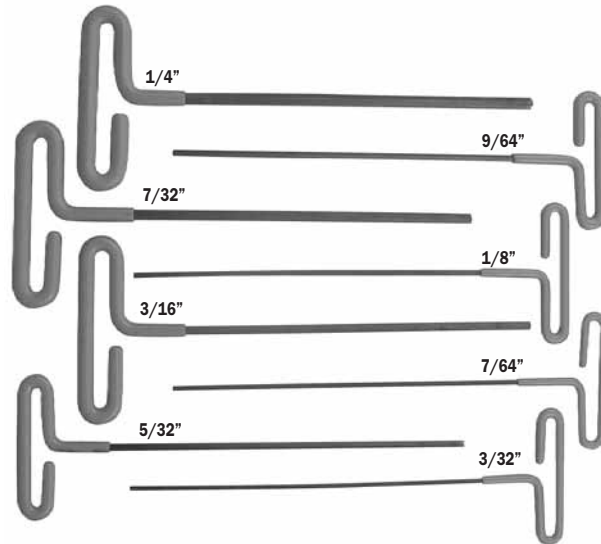

9" GRIPPED HEX "T" KEY SET

Catalog Number	Description
WT9SG	T-Handle Gripped Hex Wrench Kit 8 sizes.
INDIVIDUAL 9" LONG WRENCHES	
WT918G	1/8" T-Hex Key 9" long.
WT9532G	5/32" T-Hex Key 9" long.
WT918G	3/16" T-Hex Key 9" long.

Abrasive Cloth/Mesh	.45	Hack Saws & Blades	.50	Roofing Tools / Accessories	.12-13
Adjustable Folding Tool	.28	Hammers & Pry Bars	.58-59	Saws & Saw Blades	.50-56
Adjustable Wrenches	.62	Hand Drivers	.65-67	Scratch Awls	.30
Aluminum Handled Snips	.22-23	Hex Key Wrenches	.63-64,90	Screwdrivers	.65-66
Anchors	.75	Hex Power Drives	.68	Scribers	.30-31
Andy Snips	.22-23	Hole Cutters, Ductboard	.39	Seamers & Folding Tools	.27-28
Angle Drive Accessory	.26	Hole Cutters, Metal	.26	Self Drilling / Tapping Screws	.74-77
Aprons	.81	Hole Punches	.10, 71	Sheet Metal Brake	.29
Aviation Snips	.20-21	Hole Saws, Hole in One	.52-53	Sheet Metal Hammers	.58
AVs Snips	.21	J-Channel Cutters	.11	Sheet Metal Scribers	.30-31
Awls, Scribers & Dividers	.30-31	Knee Pads	.82	Shingle Fork	.13
Beast Shingle Remover	.12	Knives & Blades	.37, 39, 57	Shingle Removal Tools	.12-13
Bit-Tip Screws	.76-77	Levels	.46	Shinglers Hammer	.59
Caulking Guns	.19	Lightweight Snips	.22-24	Shingle Shovel	.13
Ceiling Grid Punch	.71	Magnetic Sweeps	.14-15	Sider Marking/Cutting Template	.9
Chalk Lines	.47	Mallet	.58	SideSwiper Siding Removal Tools	.8
Channel Shear	.18	Max2000 Snips	.20	Siding Tools	.6-11
Circular Saw Blades	.56	Measuring Tools	.46-49, 89	Snap Lock Punches, Gutter	.16
Circumference Rules	.48	Measuring Wheels	.49	Snap Lock Punches, Metal Duct	.32
Compass Saw & Blades	.51	Metal Duct Tools	.32-36	Snap Lock Punches, Vinyl Siding	.10
Construction Cleanup Tools	.14-15	Metal Stud Crimper	.18	Snips for Metal & Vinyl	.20-24
Crimpers, Downspout	.16	Metal Stud & Runner Shear	.18	Squares	.47
Crimpers, End Cap	.16	Mini Brake	.29	Starter Kits	.5
Crimpers, Round Duct	.33	Mini Saw	.50	Steel Snips	.24
Dampers & Hardware	.35	Nail Cutter, Siding	.7	Step Drills	.69
Distance Measuring Wheels	.49	Nail Hole Punches	.10	Straight Edge Rules	.48
Dividers	.31	Nail Punches & Drivers	.11,16	Swaging Tools	.44
Double Cut Snip	.21	Navi-Gator Snips	.24	The Sider	.9
Double Enders Drill Bits	.70	Notchers, Sheet Metal	.32	Tie Tensioning Tools	.41
Downspout Crimpers	.16	Notchers, Fiber Cement Siding	.7	Tool Boxes	.83
Drill Bits	.69-70	Nut Drivers	.67	Tool Kits	.5
Drywall Tools	.18	Nylon Ties	.41	Tool Pouches, Aprons	.78-81
Duct Connector	.36	Overlap Gauges	.6	Torpedo Levels	.46
Duct Holders	.36	Painted Fasteners	.73,75	Trammel Points	.31
Duct Knives	.37,39	Pinch-off Tool	.44	Trim Nail Punches	.11
Duct Stretchers	.34	Pipe & Duct Holders	.36	Trouble Lights	.84
Ductboard Tools	.37-39	Pipe Crimpers	.33	Tube Benders	.45
Edge Roller	.88	Plastic Anchors	.75	Tube Cutters	.42
Electric Cords & Lights	.84-85	Pliers & Wrenches	.60-62	Tubing Tools	.42-45
Electrical Pliers	.60-61	Plumbers Roll	.45	TurboShear	.25, 86, 87
Facing Gauge	.6	Pouches, Aprons & Knee Pads	.78-82	Utility Knives & Blades	.57
FasGroov	.37-38	Power Drives & Inserts	.68	Vent Saw	.51
Fasteners	.73-77	Power Shears	.25-26	Vinyl Siding Tools	.8-11
Fiber Cement Siding Tools	.6-7	Pry Bars	.59	Washer Seals	.39
Fin Straightening Tools	.45	Punch Lock Stud Crimper	.18	Wood Bits	.69
Fitting Brushes	.44	Punches / Nail Sets	.11,16	Wooden Mallet	.58
Flaring Tools	.43	Rake, Construction Cleanup	.15	Wrenches & Pliers	.60-62
Flex Duct Cutter/Shear	.40	Ratchet Wrenches	.62	Zip-in Screws	.74-75
Flex Duct Tools	.39-41	Reamer-Deburring Tools	.44		
Folding Rules	.48	Reciprocating Saw Blades	.54-55		
Folding Tools & Mini Brake	.28-29	Riveters	.72		
Gutter & Downspout Tools	.16-17	Rivets	.73		
Gutter Drops	.17	Roof Brackets	.13		
Gutter Nail Driver	.16				
Gutter Outlet Punches	.17				

Malco[®]

MALCO PRODUCTS INC.
Annandale, MN 55302 USA
www.malcotools.com

YOUR AUTHORIZED MALCO DEALER:

