

**READ AND SAVE THESE INSTRUCTIONS**

## Safety & Installation Instructions



## TABLE OF CONTENTS

### INSTALLATION

Thermostat installation location recommendations . . . . .	2
Thermostat mounting . . . . .	2
Equipment control module installation location recommendations . . . . .	2
Equipment control module mounting . . . . .	2
Thermostat wiring . . . . .	3
Remote temperature sensor (optional) . . . . .	3
Equipment control module wiring . . . . .	4
Outdoor temperature sensor . . . . .	5
Optional wireless outdoor temperature sensor . . . . .	5
Return air temperature sensor (optional) . . . . .	6
Leaving air temperature sensor (optional) . . . . .	6

### HVAC WIRING DIAGRAMS

Conventional heat/cool single transformer . . . . .	7
Conventional heat/cool two transformer . . . . .	7
Heat pump single transformer . . . . .	8
Heat pump two transformer . . . . .	8

### INDOOR AIR QUALITY WIRING DIAGRAMS

Indoor Air Quality wiring with separate transformers . . . . .	9
Indoor Air Quality wiring with a single transformer . . . . .	9

### POWER & RESET OPTIONS

Power and reset options . . . . .	10
-----------------------------------	----

### SETUP & TESTING

Equipment type selection switch (SW1) . . . . .	11
Installer setup menu . . . . .	11
Change system settings . . . . .	11
HVAC installer system settings table . . . . .	12-13
Indoor Air Quality system settings tables . . . . .	14
Air cleaning system settings table . . . . .	14
Humidifier system settings table . . . . .	14
Dehumidifier system settings table . . . . .	15
Ventilation system settings table . . . . .	15-16
System test menu . . . . .	17-18
System test tables . . . . .	18-20

### REFERENCES

Quick reference to controls & display . . . . .	21-22
Troubleshooting . . . . .	22-23
Error codes . . . . .	23
Home Comfort Control features . . . . .	23
Specifications . . . . .	24

## INSTALLATION

### THERMOSTAT INSTALLATION LOCATION RECOMMENDATIONS

#### Thermostat should be mounted:

- On an interior wall, in a frequently occupied space.
- Approximately 5' above floor.
- At least 18" from outside wall.
- Thermostat can be mounted to a vertical junction box.

#### Do not mount thermostat:

- Behind doors, in corners or other dead air spaces.
- In direct sunlight, near lighting fixtures, or other appliances that give off heat.
- On an outside or unconditioned area wall.
- In the flow of a supply register, in stairwells, or near outside doors.
- On a wall with concealed pipes or ductwork.

### THERMOSTAT MOUNTING

1. Remove the rear mounting plate from the thermostat.
2. Pull wires through the opening on the back of the thermostat.
3. Position and level the mounting plate of the thermostat on wall and mark the hole locations with a pencil.
4. Drill 1/4" holes and insert supplied anchors (drywall only).
5. Place mounting plate over anchors, insert and tighten screws.
6. Seal wire entry holes to prevent drafts affecting temperature readings.

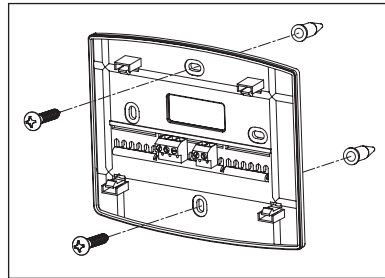

### EQUIPMENT CONTROL MODULE INSTALLATION LOCATION RECOMMENDATIONS

**Note:** Installer must touch a grounded metal object before handling the Equipment Control Module to avoid potential loss of programs due to electrical discharge.

#### Equipment control module should be mounted:

- In a location where the temperature will not exceed 158°F (70°C) or drop below 32°F (0°C).

#### Do not mount equipment control module:

- On foundation walls or on the HVAC equipment or ductwork. These locations can cause moisture to condense on the equipment control module.

### EQUIPMENT CONTROL MODULE MOUNTING

The Equipment Control Module has the following features to simplify mounting and wiring and provide for a clean and neat installation.

- Six (6) mounting holes. One on each corner and two centered top and bottom. Any combination of these holes may be utilized. Mount the Equipment Control Module using 2 to 4 #8 screws appropriate for the mounting surface substrate. (See **Figure 2**.)
- Wires can be routed through the top, bottom, sides or back.
- Nylon wire ties can be used to secure wires in 10 places.

#### Installation Steps

1. Select mounting location.
2. Pull from bottom to remove front cover. (See **Figure 1**.)
3. Mount base using 2 to 4 #8 screws (field supplied).



Figure 1

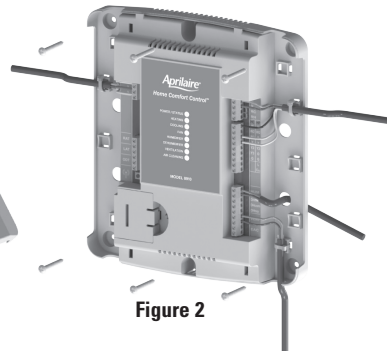

Figure 2

## INSTALLATION

### THERMOSTAT WIRING

#### Wire specifications:

18-24 gauge thermostat wire

#### Installation notes:

- Ensure power at the HVAC equipment is off.
- Loosen screw terminals, insert stripped wire and re-tighten.
- Push the excess wire back into the opening and plug the wall opening to prevent drafts.

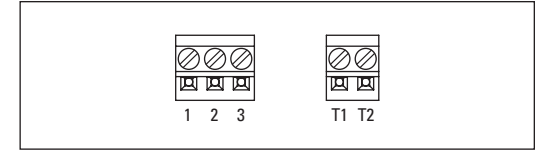

- 1 – Connection to terminal 1 at equipment control module
- 2 – Connection to terminal 2 at equipment control module
- 3 – Connection to terminal 3 at equipment control module
- T1 & T2 – Remote temperature sensor (optional)

### REMOTE TEMPERATURE SENSOR (OPTIONAL)

A remote temperature sensor can be used if the thermostat is to be mounted in a concealed location. A 8051 flush mount or 8053 surface mount remote temperature sensor can be attached to the T1 and T2 terminals and mounted in a recommended area. The remote sensor must be enabled in the installer set-up menu, and once enabled will override the thermostat's internal temperature sensor.

#### Remote temperature sensor should be mounted:

- On an interior wall, in a frequently occupied space.
- Approximately 5' above floor.
- At least 18" from outside wall.
- Using less than 300' of wire.

#### Do not mount remote sensor:

- Behind doors, in corners or other dead air spaces.
- In direct sunlight, near lighting fixtures, or other appliances that give off heat.
- On an outside or unconditioned area wall.
- In the flow of a supply register, in stairwells, or near outside doors.
- On a wall with concealed pipes or ductwork.
- Near 120 VAC lines.

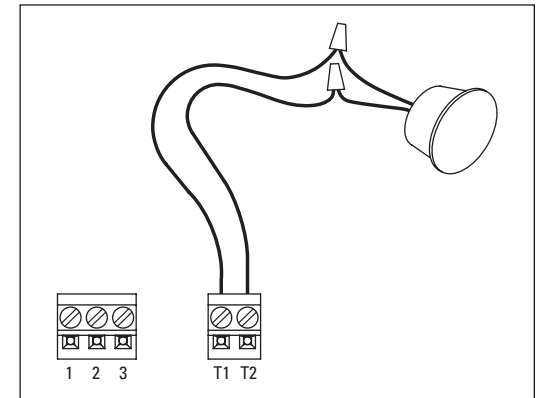

## INSTALLATION

### EQUIPMENT CONTROL MODULE WIRING

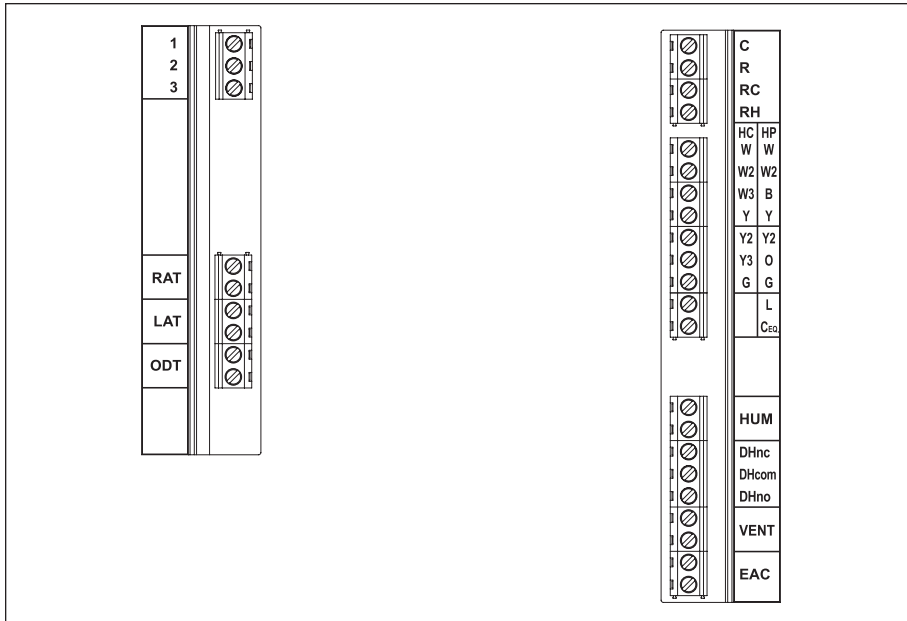

#### Wire specifications:

18-24 gauge thermostat wire

#### Installation notes:

- Ensure power at the HVAC equipment is off.
- Loosen screw terminals, insert stripped wire and re-tighten.
- Use zip tie to route wiring through the wiring channels.

- 1** – Connection to terminal 1 at thermostat
- 2** – Connection to terminal 2 at thermostat
- 3** – Connection to terminal 3 at thermostat

- RAT** – Return air temperature sensor (optional)
- LAT** – Leaving air temperature sensor (optional)
- ODT** – Outdoor temperature sensor (optional)

- C** – 24VAC common
- R** – 24VAC
- RC** – 24VAC Cooling
- RH** – 24VAC Heating
- W** – First stage heat (conventional)/auxiliary (heat pump)
- W2** – Second stage heat (conventional)/ auxiliary (heat pump)
- W3/B** – Third stage heat (conventional)/reversing valve (heat pump)
- Y** – First stage cooling (conventional)/first stage compressor (heat pump)
- Y2** – Second stage cooling (conventional)/second stage compressor (heat pump).
- Y3/O** – Third stage cooling (conventional)/reversing valve (heat pump)
- G** – Fan
- L** – System fault indicator (heat pump only) (optional)
- Ceq** – 24VAC common from heat pump for system fault indicator (optional)
- HUM** – Humidifier
- DHno & DHcom** – Normally open dehumidifier control
- DHnc & DHcom** – Normally closed dehumidifier control
- VENT** – Ventilation
- EAC** – Electronic Air Cleaner

## INSTALLATION

### OUTDOOR TEMPERATURE SENSOR

Outdoor temperature can be measured by installing an 8052 sensor (included) to the ODT terminals and enabling the outdoor sensor in the installer set-up menu. When an outdoor sensor is installed, the features below will be enabled.

#### In heat pump mode the outdoor temperature sensor can be used to efficiently utilize an air source heat pump:

- When the outdoor temperature is less than the Low Balance Point, the heat pump will be locked out and only auxiliary heating will be used.
- When the outdoor temperature is higher than the High Balance Point, the auxiliary heating will be locked out and only the heat pump will be used to provide heating.

#### Indoor Air Quality functions can use the outdoor temperature sensor to:

- Control humidification setpoint based on outdoor temperature to prevent condensation
- Lock out humidification for temperatures over 60°F or below -30°F.
- Lock out ventilation based on high and/or low outdoor temperatures.
- Display outdoor temperature on thermostat.

#### Outdoor temperature sensor should be mounted:

- On side of building out of direct sunlight (north side recommended).
- Above snow line.
- At least 3' away from exhaust vents and condensing lines.
- Using less than 300' of wire.
- Do not route wires along 120 VAC lines.

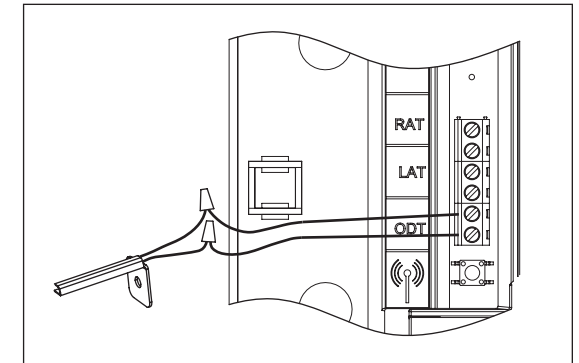

### OPTIONAL WIRELESS OUTDOOR TEMPERATURE SENSOR

For installations where it is difficult to wire the included 8052 outdoor temperature sensor, a Model 8056 wireless outdoor temperature module can be used. The Model 8056 module has two radio units, one that is placed on the equipment control module as shown below, and a second radio that is placed outside. See the Model 8056 Installation Instructions for detailed directions regarding installation.

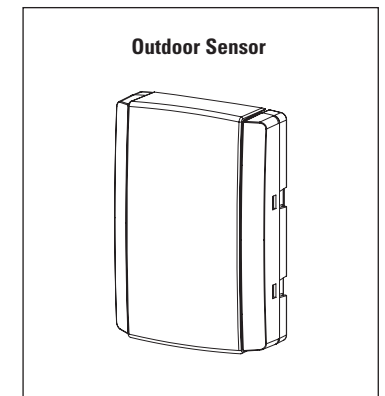
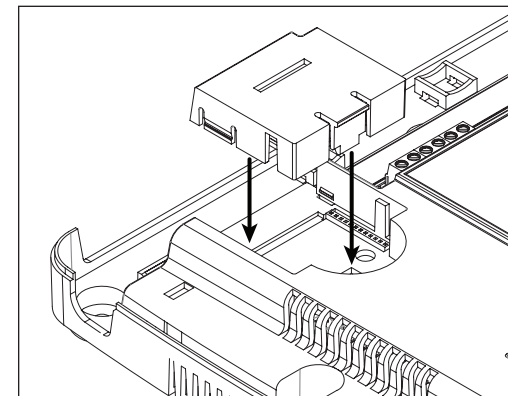

## INSTALLATION

### RETURN AIR TEMPERATURE SENSOR (OPTIONAL)

Return air temperature can be measured by attaching an 8052 sensor to the RAT terminals. The return sensor must be enabled in the installer set-up menu. The return air temperature sensor provides protection in the event that the equipment control module loses connection with the thermostat. In the event that the thermostat connection is lost, the equipment control module will use the return air temperature sensor to maintain a temperature greater than 40°F and less than 100°F.

1. Locate the Aprilaire Model 8052 sensor in the return trunk.
2. Mount the sensor according to the installation instructions provided with the sensor.
3. Wire the sensor to the equipment control module RAT terminals.

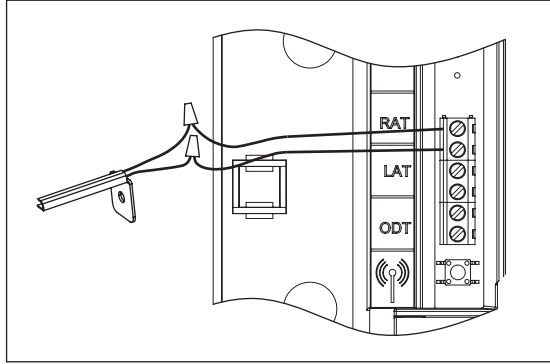

### LEAVING AIR TEMPERATURE SENSOR (OPTIONAL)

Leaving air temperature can be measured by attaching an 8052 sensor to the LAT terminals. The leaving air temperature sensor measurement is displayed during the installer test for diagnostic purposes.

#### IMPORTANT

Do not mount the sensor in direct line-of-sight of the heat exchanger, cooling coils, or UV lights as this may cause the sensor to report false temperature readings.

1. Locate the Aprilaire Model 8052 sensor in the supply trunk, after the heat exchanger and cooling coils. (See shaded areas in figure below.)
2. Mount the sensor according to the installation instructions provided with the sensor.
3. Wire the sensor to the equipment control module LAT terminals.

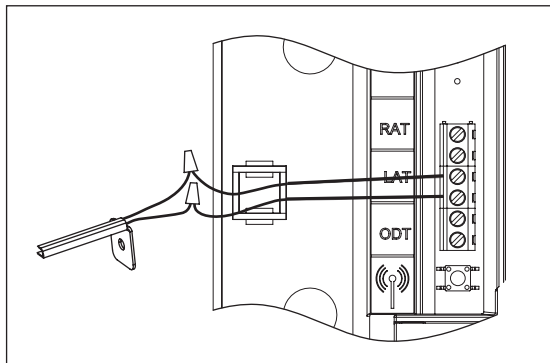
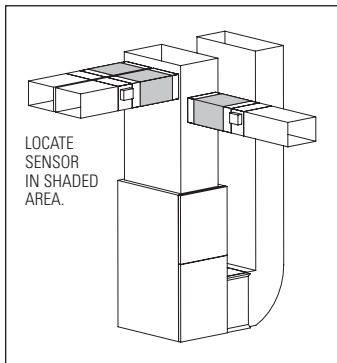

## HVAC WIRING DIAGRAMS

### CONVENTIONAL HEAT/COOL SINGLE TRANSFORMER (USE JUMPER)

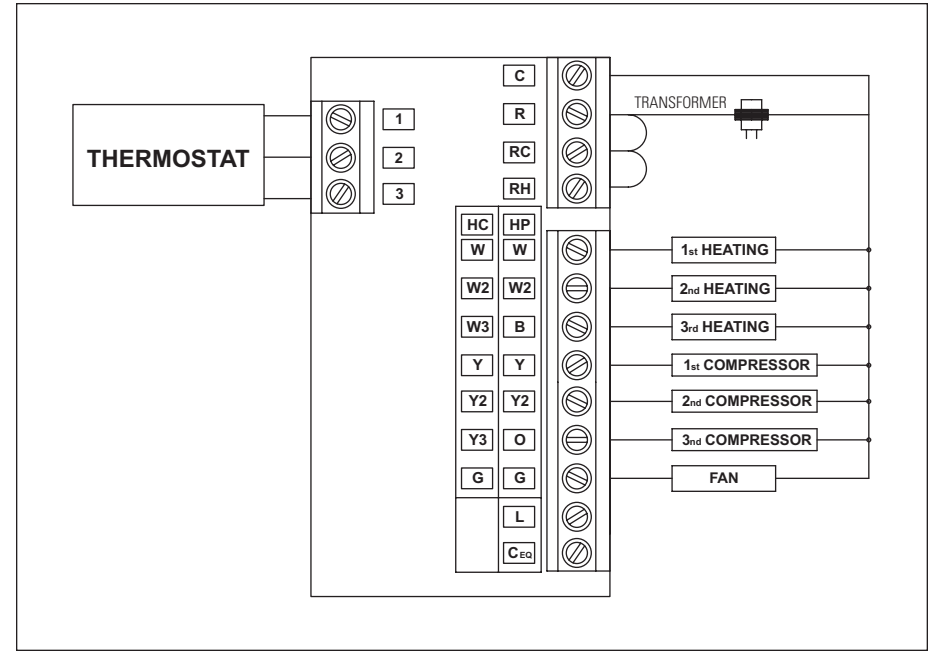

### CONVENTIONAL HEAT/COOL TWO TRANSFORMER (REMOVE JUMPER)

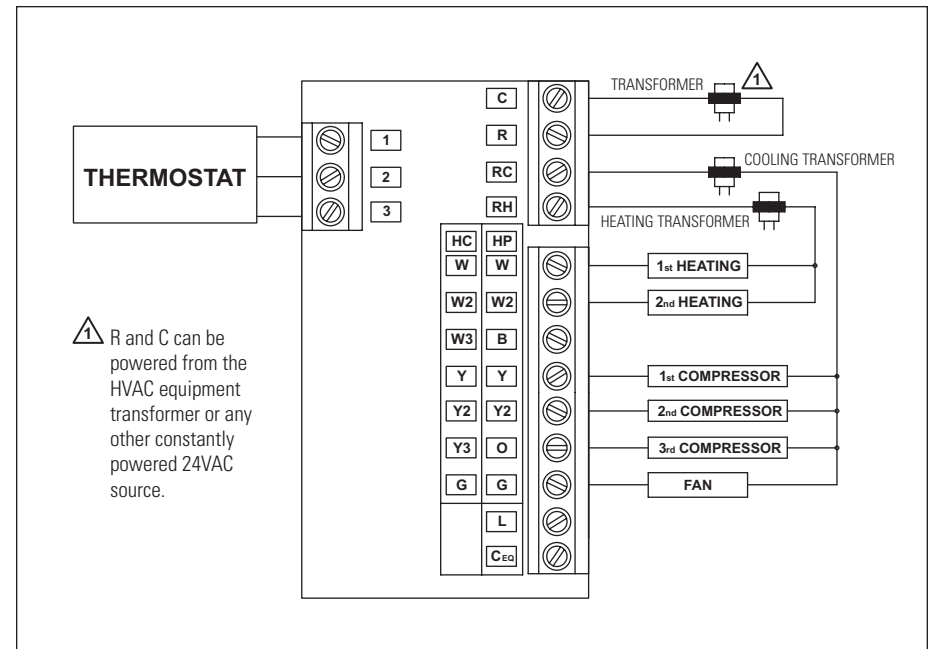

# HVAC WIRING DIAGRAMS

## HEAT PUMP SINGLE TRANSFORMER (USE JUMPER WIRE)

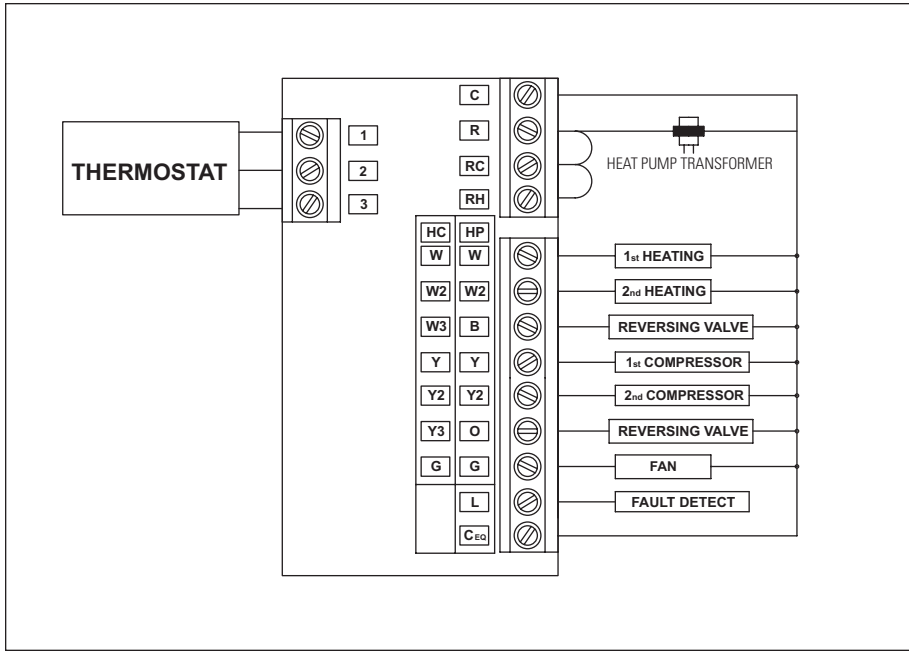

## HEAT PUMP TWO TRANSFORMER (REMOVE JUMPER WIRE)

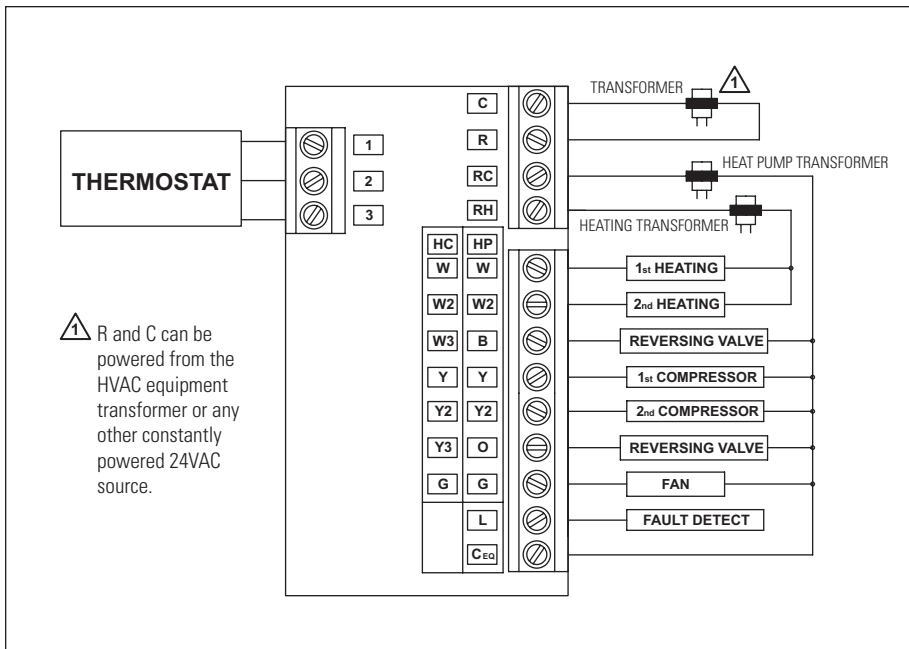

# INDOOR AIR QUALITY WIRING DIAGRAMS

## INDOOR AIR QUALITY WIRING WITH SEPARATE TRANSFORMERS

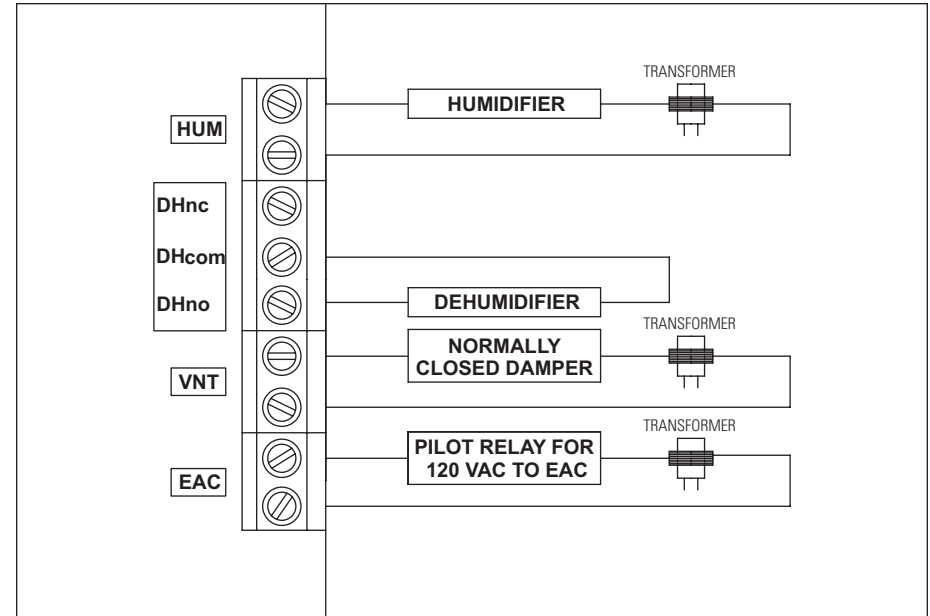

**Note:** Outputs are 24VAC dry contact. Please see individual product installation instructions for more details.

## INDOOR AIR QUALITY WIRING WITH A SINGLE TRANSFORMER

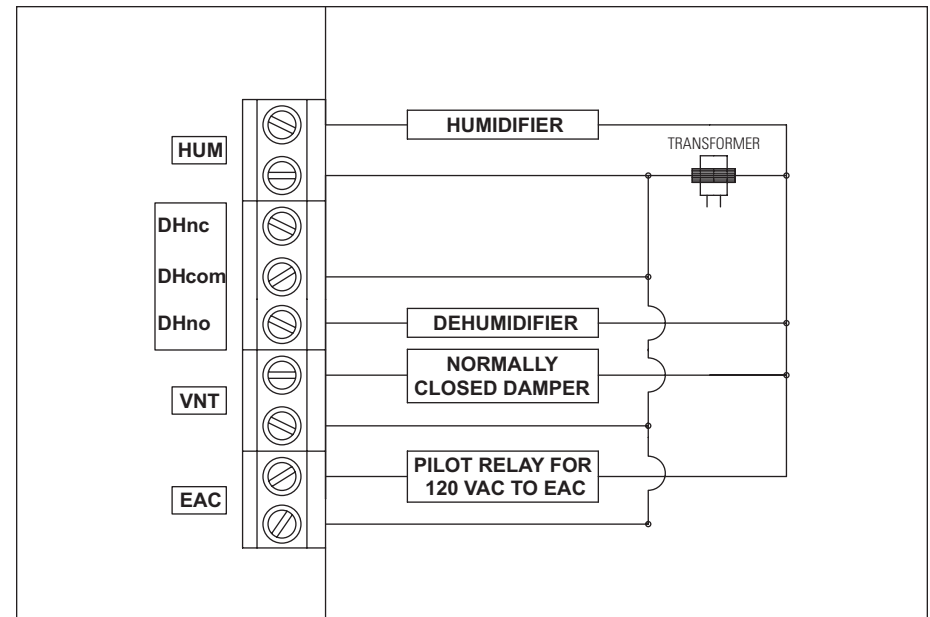

**Note:** Outputs are 24VAC dry contact. Please see individual product installation instructions for more details.

## POWER & RESET OPTIONS

The equipment control module is powered from 24VAC. The thermostat is powered from the equipment interface module and has a battery back-up option for the clock.

The thermostat has a memory backup that saves the thermostat settings in case of a power interruption. The system settings will be retained but the clock will reset after 90 seconds with no battery or equipment control module power.

The reset button located under the battery cover can be used to reset the thermostat to factory defaults. The system settings will also be reset to default.

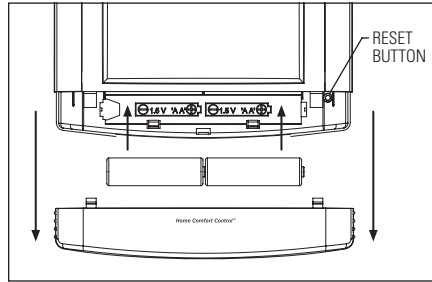

## SETUP & TESTING

### EQUIPMENT TYPE SELECTION SWITCH (SW1)

This Home Comfort Control has the option of being used in heat pump or heat/cool systems. Switch SW1 located on the back of the thermostat's face is used to select this option. This setting is displayed in the Installer System Settings under Equipment Type.

**Note:** Home Comfort Control reboots within 10 seconds after switch position is changed.

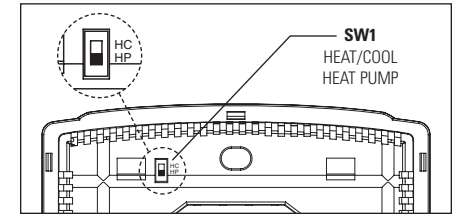

### INSTALLER SETUP MENU

#### HOW TO ENTER THE INSTALLER SETUP MENU AND SELECT EQUIPMENT TO SETUP:

In the Installer Setup, HVAC or Indoor Air Quality setup can be selected. If Indoor Air Quality setup is selected, the user can then select to set up Air Cleaning, Humidification, Dehumidification or Ventilation.

Press **[MODE]** to set system to OFF.

Press **[MENU]** to enter main menu.

Press and hold **[SETUP]** for seven seconds, **[INSTALL SETUP]** appears.

Press **[INSTALL SETUP]** to enter installer setup menu.

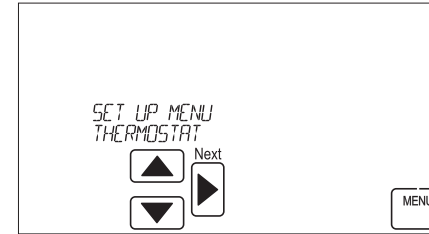

Press **▲** or **▼** to adjust the option.

Press **[MENU]** to exit.

Press **[NEXT]** to select option.

If IAQ (Indoor Air Quality) was selected, Press **▲** or **▼** to adjust the Outdoor Sensor setting or IAQ (Indoor Air Quality) option.

Press **[NEXT]** to select Outdoor Sensor setting or IAQ (Indoor Air Quality) option.

System Settings can now be changed.

### CHANGE SYSTEM SETTINGS

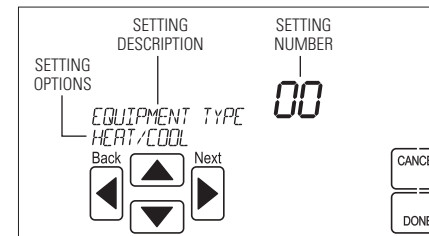

Press **[NEXT]** or **[BACK]** to page through the settings.

Press **▲** or **▼** to adjust the setting.

Press **[DONE]** to save and exit, or **[CANCEL]** to exit without saving.

The thermostat will discard changes and exit if nothing is pressed within 60 seconds.

To reset the installer settings to the default, reset the thermostat by pressing the **[RESET]** button for 5 seconds.

## SETUP & TESTING

### HVAC INSTALLER SYSTEM SETTINGS TABLE

The following table contains the system settings and their details. Default settings are shown in **bold**. Some settings are only available dependent upon the value of other settings.

System setting	Description	Factory default setting (bold) and setting range
00. Equipment Type	Equipment type set by SW1.	<b>Heat /Cool</b> Heat Pump
01. Control Setup	Used to lockout heating or cooling outputs. (Only available in Heat/Cool mode.)	<b>Heat and Cool</b> Heat Only Cool Only
02. Number of Stages	Number of equipment stages. (Three is only available in Heat/Cool mode.)	<b>One</b> Two Three
03. Aux Heat Stages	Number of auxiliary heat equipment stages.	<b>One</b> Two
04. Temperature Scale	Set the thermostat to Fahrenheit or Celsius mode.	<b>Fahrenheit</b> Celsius
05. Heat/Cool: Fan Control in Heating Heat Pump: Auxiliary Equipment Type	Heat/Cool: Determines if the thermostat or equipment controls the fan in heating. Heat Pump: Auxiliary Equipment type.	<b>Gas/Oil Heat</b> (equipment controls fan) Electric Heat (thermostat controls fan)
06. Extended Fan – Heat	Extends fan operation after heat call ends.	<b>Disable</b> Enable (90 second extension)
07. Extended Fan – Cool	Extends fan operation after cool call ends.	<b>Disable</b> Enable (90 second extension)
08. Internal Temp Sensor Offset	Field adjustment of internal temperature sensor.	<b>0°</b> (no offset applied) -4°F to +4°F (-2°C to +2°C)
35. Internal RH Sensor Offset	Field adjustment of internal RH sensor.	<b>0</b> (no offset applied) -5% to +5%
09. Auto Changeover	Enable or disable auto changeover mode.	<b>Disable</b> Enable
26. Deadband	Auto Changeover mode deadband.	<b>3°F (2°C)</b> 2°F to 9°F (1°C to 5°C)
10. Remote Sensor	Select if remote sensor is attached.	<b>No</b> Yes
11. Outdoor Sensor	Select if outdoor sensor is attached or not.	<b>No</b> Yes
35. Return Sensor	Select if return sensor is attached or not.	<b>No</b> Yes
12. Compressor Min Off Time	Minimum off time for compressor protection.	<b>5 minutes</b> 1 to 5 minutes
13. Heating Min Off Time	Minimum off time for heating.	<b>2 minutes</b> 1 to 5 minutes
14. Equipment Min On Time	Minimum on time for heating and cooling.	<b>2 minutes</b> 1 to 5 minutes
15. Auto Changeover Time	Minimum time between heating and cooling calls.	<b>4 minutes</b> 1 to 5 minutes
16. First Stage Differential	1st stage differential.	<b>1°F (0.5°C)</b> 1°F to 9°F (0.5°C to 4.5°C)
17. Second Stage Differential	2nd stage differential.	<b>1°F (0.5°C)</b> 1°F to 9°F (0.5°C to 4.5°C)
18. Third Stage Differential	3rd stage differential.	<b>1°F (0.5°C)</b> 1°F to 9°F (0.5°C to 4.5°C)

## SETUP & TESTING

### HVAC INSTALLER SYSTEM SETTINGS TABLE (CONTINUED)

System setting	Description	Factory default setting (bold) and setting range
19. Fourth Stage Differential	4th stage differential.	<b>1°F (0.5°C)</b> 1°F to 9°F (0.5°C to 4.5°C)
20. Heat Blast	Enables the Heat Blast feature.	<b>Disable</b> Enable
21. Blast Offset	Amount of heating when Heat Blast is initiated.	<b>3°F (2°C)</b> 3°F to 5°F (2°C to 3°C)
22. Screen Lockout	Screen lockout level. (Override lockout by holding [MENU] for 7 seconds.)	<b>Off</b> Part Full
23. Partial Lockout Type	Select lockout type. (Only available when screen lockout is set to partial.)	<b>Fan/Mode/Setpt</b> Fan/Setpoints Setpoints Only
24. Max Temp Setpoint Change In Lockout	Select temperature setpoint limits. (Only available when screen lockout is set to partial.)	<b>3 degrees</b> 0 to 20 degrees
41. Max Dehum Setpoint Change In Lockout	Select dehumidification setpoint limits. (Only available when screen lockout is set to partial.)	<b>5 Percent RH</b> 0 to 15 Percent RH
25. Stage Rate	Accumulation of equipment run time in equipment staging determination. 1 = more rapid staging of equipment (comfort) 5 = slower staging of equipment (economy)	<b>2</b> 1 to 5 or "OFF" to ignore accumulated run time.
27. Progressive Recovery	Enable or disable progressive recovery.	Disable <b>Enable</b>
28. Low Balance Point	Outdoor temperature low balance point. (This option is only displayed if the outdoor sensor is enabled.)	<b>20°F (-6°C)</b> 10°F to 50°F (-12°C to 9°C) or OFF to ignore
29. High Balance Point	Outdoor temperature high balance point. (This option is only displayed if the outdoor sensor is enabled.)	<b>65°F (18°C)</b> 40°F to 85°F (3°C to 18°C) or OFF to ignore
30. Program Format	Select weekly program format.	<b>7-Day</b> (Mon, Tue, Wed, Thu, Fri, Sat, Sun) 5/1/1 (weekdays, Saturday and Sunday) 5/2 Weekdays (weekdays and weekends) Non-Prog
32. Events Per Day	Number of program events per day.	<b>Four</b> Two
33. Reset Service Reminders	Clears the Change Air Filter and HVAC and Dehumidifier Service reminders if they are active and resets the start date to the current date. Clears the Change Water Panel reminder if it is active. If the reminder is set to timed, the clock will be reset.	<b>No</b> Yes
37. HVAC Service Reminder	The period for displaying the "HVAC Service Reminder" message.	<b>Off</b> 1 to 12 months or "Off" to disable
38. Constant Backlight	Enable constant, low intensity backlight when 24VAC is present.	<b>Disable</b> Enable
39. Backlight Intensity	Backlight intensity as a percentage of full on.	100 Percent 0 to 100 Percent
40. Auto Daylight Savings	Enable or disable auto daylight savings.	Off <b>March</b> (second Sunday in March to the first Sunday in November) April (first Sunday in April to the last Sunday in October)

## SETUP & TESTING

### INDOOR AIR QUALITY SYSTEM SETTINGS TABLES

The following tables contain the Indoor Air Quality system settings and their details. Default settings are shown in **bold**. Some settings are only present dependent upon the value of other settings.

The use of an outdoor temperature sensor (recommended) enables additional Indoor Air Quality functionality. If the outdoor temperature sensor was not enabled in the HVAC system settings, HVAC system setting 11, outdoor sensor, will be presented prior to entering the Indoor Air Quality system settings.

Please refer to the Model 8910 Owner's Manual for further information about Home Comfort Control features.

#### Air Cleaning System Settings Table

System setting	Description	Factory default setting (bold) and setting range
Air Cleaner Installed	Selects if an air cleaner is installed. (If set to no, no other air cleaning settings will be available.)	<b>No</b> Yes
Change Air Filter Reminder	The period for displaying the "Change Air Filter" message.	<b>Off</b> 1 to 12 months or "Off" to disable

#### Humidifier System Settings Table

System setting	Description	Factory default setting (bold) and setting range
Humidifier Installed	Selects if a humidifier is installed. (If set to no, no other humidifier settings will be available.)	<b>No</b> Yes
Humidity Setpoint Deadband	Select the minimum difference between the humidifier and dehumidifier setpoints. (Only available if both a humidifier and dehumidifier are installed. Available in both set-ups.)	10 Percent RH 10 to 20 Percent RH
Humidifier Mode	Selects auto or manual mode. Auto mode controls humidity based on the humidity setting and outdoor temperature. Manual mode controls humidity based on the %RH setpoint. (Auto mode is only available if outdoor sensor is set to yes.)	<b>Auto</b> Manual
Humidifier Operation	Selects when humidification is allowed to occur relative to heating and fan operation.	<b>Heat Only</b> Heat or Fan Forces Fan
Change Water Panel Reminder	Selects the when the "Change Water Panel" message is displayed.	<b>Off</b> 1 Per Season 2 Per Season 300 Hours 600 Hours
Reminder Month (Change Water Panel Reminder set to 1 per Season)	Change Water Panel Reminder set to 1 per Season: Determines the month the "Change Water Panel" message is displayed.	<b>October</b> November December January
First Reminder Month (Change Water Panel Reminder set to 2 per Season)	Change Water Panel Reminder set to 2 per Season: Determines the first month the "Change Water Panel" message is displayed.	February March April May June July August September
Second Reminder Start Month	Determines the second month the "Change Water Panel" message is displayed. (Only available when Change Water Panel Reminder set to 2 per Season.)	October November December <b>January</b> February March April May June July August September

## SETUP & TESTING

### Dehumidifier System Settings Table

System setting	Description	Factory default setting (bold) and setting range
Dehumidifier Control	Selects method of dehumidification. (If set to none, no other dehumidifier settings will be available.)	<b>None</b> (no dehumidification installed) Whole Home Air Conditioner
Humidity Setpoint Deadband	Select the minimum difference between the humidifier and dehumidifier setpoints. (Only available if both a humidifier and dehumidifier are installed. Available in both set-ups.)	10 Percent RH 10 to 20 Percent RH
Lockout Dehumidifier During Cooling	Selects if dehumidification is disabled during a cooling call.	No <b>Yes</b>
Dehumidifier Forces Fan	Select if dehumidification can turn on the fan.	No <b>Yes</b>
Dehumidifier Service Reminder	The period for displaying the "Dehum Service Reminder" message.	<b>Off</b> 1 to 12 months or "Off" to disable
Dehumidifier Overcooling Limit	Selects the amount of overcooling that can occur for dehumidification. (Only available if dehum control is set to air conditioner.)	<b>3°F (1.5°C)</b> 1°F to 3°F (0.5°C to 1.5°C)
Dehumidify in Vacation Mode	Selects if dehumidification with the air conditioner is done in Vacation Mode. (Only available if dehum control is set to air conditioner.)	<b>No</b> Yes
Vacation Dehumidifier Low Temp Limit	Sets the lowest temperature the air conditioner will cool to meet RH setpoint in Vacation Mode. (Only available if dehum control is set to air conditioner.)	<b>75°F (24°C)</b> 70°F to 85°F (21°C to 29°C)

**Note:** Refer to manuals for humidifier, dehumidifier, air cleaner and ventilation products for recommended installation and operation.

### Ventilation System Settings Table

System setting	Description	Factory default setting (bold) and setting range
Fresh Air Vent Installed	Selects if ventilation is installed. (If set to no, no other ventilation settings will be available.)	<b>No</b> Yes
Fresh Air Forces Fan	Selects if ventilation forces the fan on.	No <b>Yes</b>
Fresh Air Setup	Selects if ventilation is configured through the ASHRAE setup or Timed. If ASHRAE setup is selected, the hourly ventilation time will be calculated using the ASHRAE recommendations. If Timed set-up is selected, the hourly ventilation time will be determined based on the Fresh Air Time value.	<b>Timed</b> ASHRAE
Fresh Air Time	Selects how many minutes per hour that ventilation will be active. (Only available if fresh air setup is set to timed.)	<b>30 MIN/HR</b> 0 to 60 MIN/HR
High Limit Outdoor Temp	Selects if ventilation is disabled if the outdoor temperature exceeds the outdoor high limit. (Only available if fresh air setup is set to timed and an outdoor temperature sensor is installed.)	<b>No</b> Yes
Outdoor High Limit	Sets the high temperature limit for ventilation. (Only available if high limit outdoor temp set to yes.)	<b>100°F (38°C)</b> 90°F to 100°F (32°C to 44°C)
Low Limit Outdoor Temp	Selects if ventilation is disabled if the outdoor temperature exceeds the outdoor low limit. (Only available if fresh air setup is set to timed and an outdoor temperature sensor is installed.)	<b>No</b> Yes
Outdoor Low Limit	Sets the low temperature limit for ventilation. (Only available if low limit outdoor temp set to yes.)	<b>10°F (-7°C)</b> -10°F to 30°F (-29°C to -1°C)
High Limit Indoor RH	Selects if ventilation is disabled if the indoor RH exceeds the indoor RH limit. (Only available if fresh air setup is set to timed.)	<b>No</b> Yes
Indoor RH Limit	Sets the high indoor RH limit for ventilation. (Only available if high limit indoor RH is set to yes.)	<b>60%</b> 50% to 70%



## SETUP & TESTING

Ventilation System Settings Table (continued)

System setting	Description	Factory default setting (bold) and setting range
Number of Bedrooms	Selects the number of bedrooms to be used for the ASHRAE calculation. (Only available if fresh air setup is set to ASHRAE.)	<b>3 Bedrooms</b> 1 to 6 Bedrooms
Number of Occupants	Selects the number of occupants to be used for the ASHRAE calculation. (Only available if fresh air setup is set to ASHRAE.)	<b>4 Occupants</b> 1 to 10 Occupants
Home Size	Selects the home size to be used for the ASHRAE calculation. (Only available if fresh air setup is set to ASHRAE.)	<b>2500 SQ FT</b> 1000 to 5000 SQ FT
Fresh Air CFM	Selects the ventilation CFM to be used for the ASHRAE calculation. (Only available if fresh air setup is set to ASHRAE.)	<b>60 CFM</b> 30 to 200 CFM
Select Climate	Selects the climate to be used for the ASHRAE calculation. (Only available if fresh air setup is set to ASHRAE.) To determine what region you are in, refer to the map below.	<b>Normal</b> Very Hot/Humid Very Cold
ASHRAE Cycle Time	Displays the Fresh Air Time calculated by the ASHRAE standard. (Only displayed if fresh air setup is set to ASHRAE.)	Minutes/Hour

**Note:** In ASHRAE set-up temperature and humidity limits are disabled.

### CLIMATE MAP FOR ASHRAE FRESH AIR SETUP

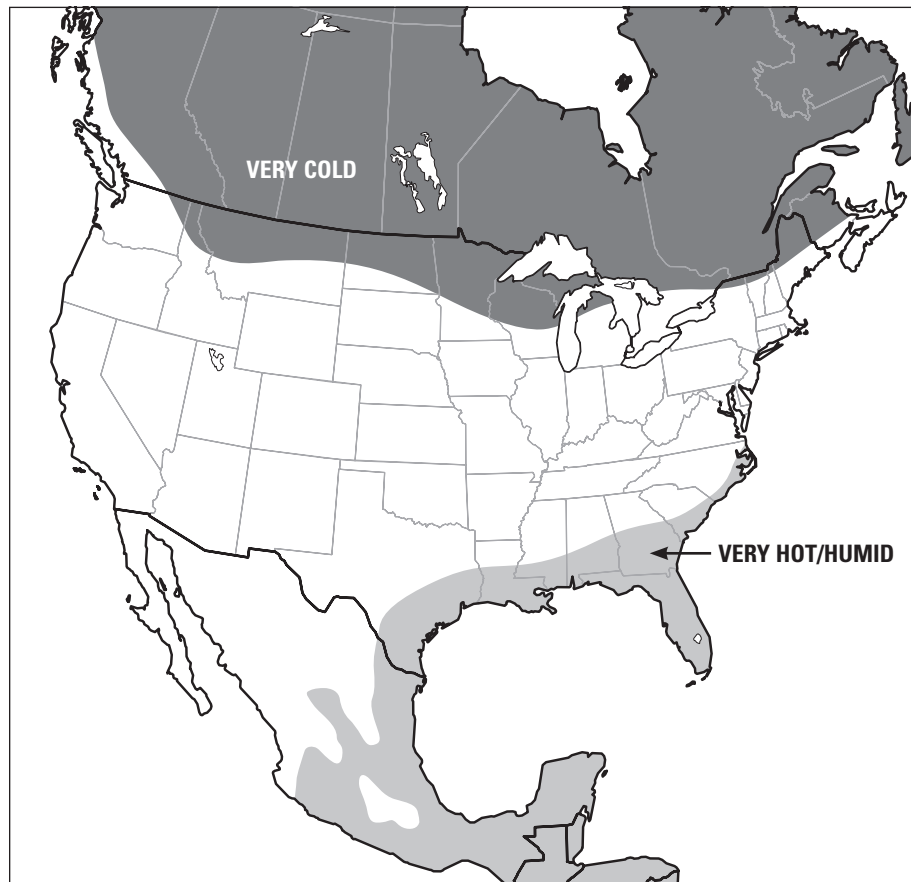

## SETUP & TESTING

### SYSTEM TEST MENU

The system test menu is used to test a system after installation. The outputs of the Home Comfort Control can be manually activated to test their function. The instructions below show how to enter the test mode and turn outputs on and off.

#### HOW TO ENTER THE SYSTEM TEST MENU:

Press **[MODE]** to set system to off.

Press and hold **[FAN]** and **[MODE]** for three seconds to enter system test mode.

The first screen of the installer test displays the equipment configuration.

Press **[NEXT]** to enter the first installation test or **[CANCEL]** to exit.

#### SYSTEM TEST STEPS

- Heating equipment test
- Cooling equipment test
- Fan equipment test
- Humidification equipment test
- Dehumidification equipment test
- Ventilation equipment test
- Air Cleaning equipment test

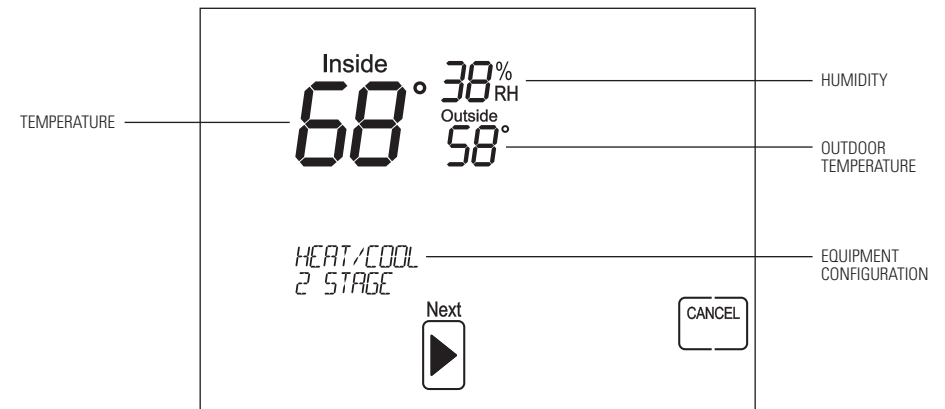

Each equipment test will begin with the selection of turning on the output or stage as shown below.

Press **▲** or **▼** to change the selection.

Press **[NEXT]** to accept the selection and proceed to the next step.

If **YES** is selected, the Home Comfort Control will test the corresponding output. If **NO** is selected, the Home Comfort Control will proceed to the next step.

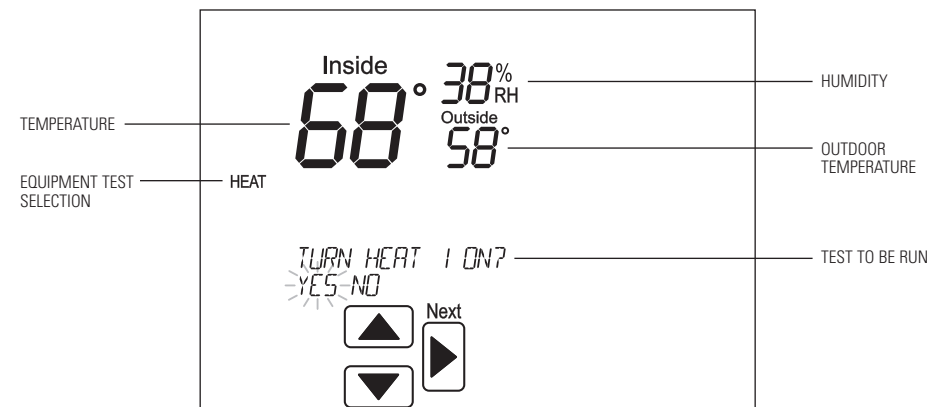

## SETUP & TESTING

### SYSTEM TEST MENU (CONTINUED)

While the equipment test is active the corresponding test information will be shown.

Press **[NEXT]** to accept the selection and proceed to the next test selection.

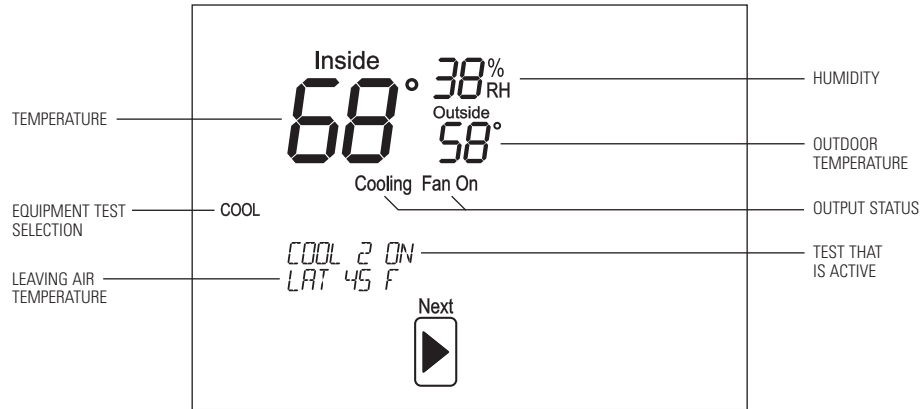

### SYSTEM TEST TABLES

Heat / Cool Heating Equipment Test								
Heat Type		W	W2	W3	Y	Y2	Y3	G
Gas	1st Stage Test	ON						
Gas	2nd Stage Test	ON	ON					
Gas	3rd Stage Test	ON	ON	ON				
Electric	1st Stage Test	ON						ON
Electric	2nd Stage Test	ON	ON					ON
Electric	3rd Stage Test	ON	ON	ON				ON

## SETUP & TESTING

### SYSTEM TEST TABLES (CONTINUED)

Heat Pump Heating Equipment Test (Electric Heat)									
Compressor Stages	Aux Stages		W	W2	B	Y	Y2	O	G
1	1	1st Stage Test			ON	ON			ON
1	1	2nd Stage Test	ON		ON	ON			ON
2	1	1st Stage Test			ON	ON			ON
2	1	2nd Stage Test			ON	ON	ON		ON
2	1	3rd Stage Test	ON		ON	ON	ON		ON
1	2	1st Stage Test			ON	ON			ON
1	2	2nd Stage Test	ON		ON	ON			ON
1	2	3rd Stage Test	ON	ON	ON	ON			ON
2	2	1st Stage Test			ON	ON			ON
2	2	2nd Stage Test			ON	ON	ON		ON
2	2	3rd Stage Test	ON		ON	ON	ON		ON
2	2	4th Stage Test	ON	ON	ON	ON	ON		ON

Heat Pump Heating Equipment Test (Gas Heat)									
Compressor Stages	Aux Stages		W	W2	B	Y	Y2	O	G
1	1	1st Stage Test			ON	ON			ON
1	1	2nd Stage Test	ON		ON				
2	1	1st Stage Test			ON	ON			ON
2	1	2nd Stage Test			ON	ON	ON		ON
2	1	3rd Stage Test	ON		ON				
1	2	1st Stage Test			ON	ON			ON
1	2	2nd Stage Test	ON		ON				
1	2	3rd Stage Test	ON	ON	ON				
2	2	1st Stage Test			ON	ON			ON
2	2	2nd Stage Test			ON	ON	ON		ON
2	2	3rd Stage Test	ON		ON				
2	2	4th Stage Test	ON	ON	ON				

## SETUP & TESTING

### SYSTEM TEST TABLES (CONTINUED)

Heat / Cool Cooling Equipment Test							
	W	W2	W3	Y	Y2	Y3	G
1st Stage Test				ON			ON
2nd Stage Test				ON	ON		ON
3rd Stage Test				ON	ON	ON	ON

Heat Pump Cooling Equipment Test							
	W	W2	B	Y	Y2	O	G
1st Stage Test				ON		ON	ON
2nd Stage Test				ON	ON	ON	ON

Fan Equipment Test							
W	W2	W3/B	Y	Y2	Y3/O	G	
						ON	

Humidification Equipment Test				
HUM	DHno/DHcom	VENT	EAC	G
ON				ON

Dehumidification Equipment Test				
HUM	DHno/DHcom	VENT	EAC	G
	ON			ON

Ventilation Equipment Test				
HUM	DHno/DHcom	VENT	EAC	G
		ON		ON

Ventilation Equipment Test				
HUM	DHno/DHcom	VENT	EAC	G
			ON	ON

## QUICK REFERENCE TO CONTROLS & DISPLAY

### HOME SCREEN

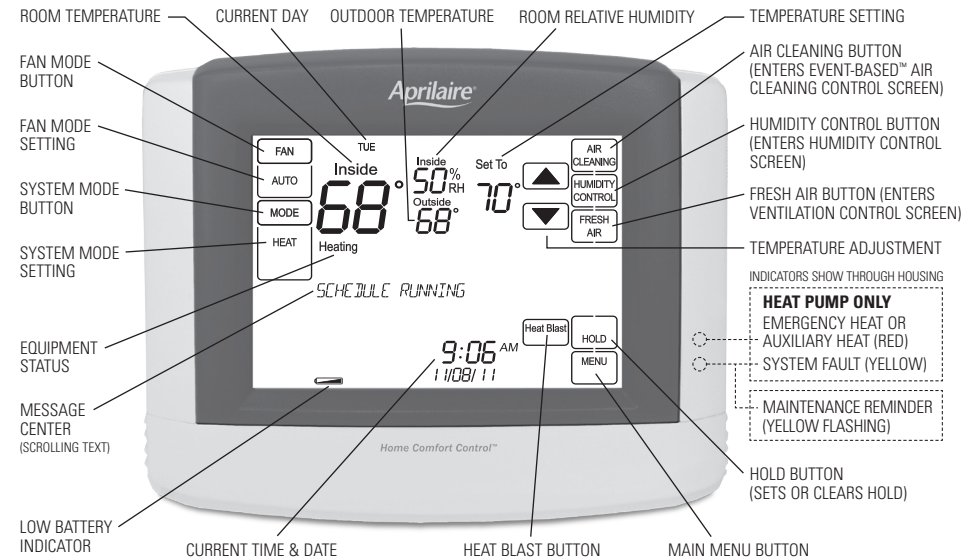

**NOTE:** BACKLIGHT IS ACTIVATED WITH FIRST BUTTON PRESS AND AUTOMATICALLY TURNS OFF.

### MAIN MENU

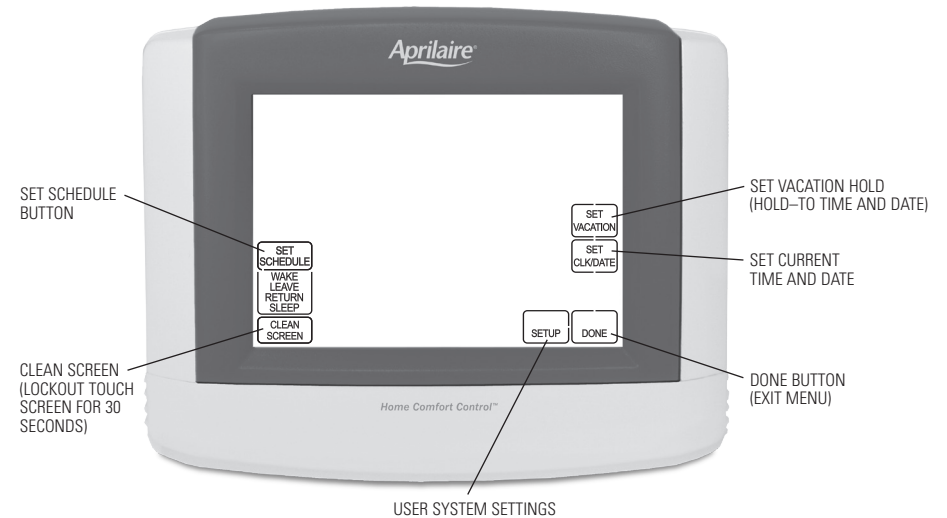

## QUICK REFERENCE TO CONTROLS & DISPLAY

### EQUIPMENT CONTROL MODULE LEDs

**POWER/STATUS** – On solid during normal operation. Flashes when connection to the thermostat is lost and at power-up while the thermostat connection is being established.

**HEATING** – On when heating outputs are active.

**COOLING** – On when cooling outputs are active.

**FAN** – On when fan output is active.

**HUMIDIFIER** – On when humidifier output is active.

**DEHUMIDIFIER** – On when dehumidifier output is active.

**VENTILATION** – On when ventilation output is active.

**AIR CLEANING** – On when air cleaner output is active.



## TROUBLESHOOTING

### DISPLAY IS BLANK

If Power LED not illuminated at the equipment control module check the following.

- Check circuit breaker and reset if necessary.
- Make sure power switch at heating & cooling system is on.
- Make sure furnace door is closed securely.

### HEATING SYSTEM DOES NOT RESPOND (“HEATING” APPEARS ON SCREEN)

- Check for 24VAC at the equipment on the secondary side of the transformer between power and common. If voltage is not present, check the heating equipment to find the cause of the problem.
- Check for 24VAC between the heat terminal (W) and the transformer common. If 24VAC is present, the Home Comfort Control is functional. Check the heating equipment to find the cause of the problem.
- Check for loose or broken wires between the Home Comfort Control and the heating equipment.

### COOLING SYSTEM DOES NOT RESPOND (“COOLING” APPEARS ON SCREEN)

- Check for 24VAC at the equipment on the secondary side of the transformer between power and common. If voltage is not present, check the cooling equipment to find the cause of the problem
- Check for 24VAC between the cooling terminal (Y) and the transformer common. If 24VAC is present, the Home Comfort Control is functional. Check the cooling system to find the cause of the problem.
- Check for loose or broken wires between the Home Comfort Control and the cooling equipment.

### FAN DOES NOT TURN ON IN A CALL FOR HEAT

- Check System Setting 09 (Fan Control), to make sure the fan control is properly set to match the type of system.

### HEAT PUMP ISSUES COOL AIR IN HEAT MODE, OR WARM AIR IN COOL MODE

- Check wiring at the terminal block to confirm the reversing valve is connected to the proper terminal. O is active in cooling and B is active in heating.

## TROUBLESHOOTING

### HEAT/COOL BOTH ON AT SAME TIME

- Check SW1 (Equipment Type), to make sure it is set to match the installed heating/cooling equipment.
- Check to make sure heating and cooling wires are not shorted together.

### HEATING EQUIPMENT IS RUNNING IN COOL MODE

- Check SW1 (Equipment Type), to make sure it is set to match the installed heating/cooling equipment (see page 11).

### “HEATING” IS NOT DISPLAYED

- Check Installer System Setting number 05 (Control Setup) is set correctly.
- Change the System Mode to Heat, and set the temperature level above the current room temperature.

### “COOLING” IS NOT DISPLAYED

- Check Installer System Setting number 05 (Control Setup) is set correctly.
- Change the System Mode to Cool, and set the temperature level below the current room temperature.

## ERROR CODES

If the thermostat enters an error mode, all outputs are turned off. The thermostat attempts to recover every 10 minutes. If the error does not clear, use the reset button. This will return all settings back to factory default.

Error code	Message	Error Description
01	“SENSOR ERROR”	Open temperature sensor circuit
02		Shorted temperature sensor circuit
03	“EEPROM ERROR”	Error in permanent memory
05	“LOST SYSTEM CONNECTION”	Thermostat lost connection to equipment interface module

## HOME COMFORT CONTROL™ FEATURES

- Indoor air quality control.
  - Humidification automatic or manual control.
  - Dehumidification.
  - Event-Based™ air cleaning.
  - Ventilation with temperature and humidity limits.
- Temperature control.
- Heat Blast™ raises the room temperature 3°F to 5°F.
- Support for optional wireless outdoor temperature sensor.
- Large touch screen with adjustable backlight – constant backlight option available.
- Message center provides feedback and instructions.
- 7 day programmability or separately programmable weekday/weekend schedules.
- Thermostat can be removed from the wall for easy programming (batteries must be installed).
- Front battery door access for fast, easy replacement.
- Displays room temperature, room humidity, temperature setting, and optional outdoor temperature.
- Air filter, humidifier, dehumidifier, and HVAC service reminders.
- Programmable fan control with fan circulation mode.
- Easy to use temperature control can override program schedule at any time.
- Progressive recovery ensures proper temperature at the start of a program event.
- Built in compressor protection prevents damage to your equipment.
- System test mode.

# SPECIFICATIONS

Environment	
Temperature (Shipping)	-30° to 150°F (-34° to 65°C)
Temperature Thermostat (Operating)	32° to 120°F (0° to 48°C)
Temperature Equipment Control Module (Operating)	32° to 158°F (0° to 70°C)
Relative humidity	Operating: 5% to 90% R.H. (non-condensing)

Electrical	
Operating voltage	24VAC (18 – 30VAC)
Current	Maximum: 2.5A (total), 1.0A (single output) Maximum surge current: 5A
Battery back-up	AA size alkaline battery x 2

Control	
Outdoor, Remote, Leaving and Return temperature sensor	Maximum distance: 300 feet
Room temperature measurement	Display range: 32° to 99°F (0° to 40°C)
Return and Leaving temperature measurement	Display range: -20° to 160°F (-30° to 71°C)
Outdoor temperature measurement	Display range: -20° to 130°F (-30° to 55°C)
Setpoint temperature range	Heat: 40° to 90°F (4° to 32°C) Cool: 50° to 99°F (10° to 37°C)
Setpoint humidity range	Humidification: 10% to 50% R.H. Dehumidification: 50% to 90% R.H.



P.O. Box 1467 • Madison, WI 53701-1467 • Phone: 800/334-6011 • Fax: 608/257-4357

[www.aprilairepartners.com](http://www.aprilairepartners.com)