

Data Sheet

TWA Thermal Wax Actuator

Application

The TWA is a small actuator for electrical on/off - controls to activate several types of valves and floor heating manifolds. The actuator is equipped with a visual position indicator to show the open or closed position of the valve. The TWA range covers actuators for 24 V (SELV) or 230 V supply in both normally closed (NC) or normally open (NO) versions (valve positions with no supply voltage to the actuator), and the 24 V TWA for RA valves also comes in a NC/S-version with an end-switch.

The TWA can be connected to the RA, RTD, RAVL and RAV-valves from Danfoss. Furthermore versions for valves with Heimeier/MNG/Oventrop M30x1.5 connection are available. Other valves must be verified individually to ensure correct valve closing measurement and valve top geometry.



Ordering

Actuator	Connection type	Supply Voltage	Function	Order Number
TWA-A	RA	24 V AC/DC	NC	088H3110
TWA-A	RA	24 V AC/DC	NO	088H3111
TWA-A	RA	230 V AC	NC	088H3112
TWA-A	RA	230 V AC	NO	088H3113
TWA-A	RA	24 V AC/DC	NC/S*	088H3114
TWA-V	RAV/VMT	24 V AC/DC	NC	088H3120
TWA-V	RAV/VMT	24 V AC/DC	NO	088H3121
TWA-V	RAV/VMT	230 V AC	NC	088H3122
TWA-V	RAV/VMT	230 V AC	NO	088H3123
TWA-L	RAVL	24 V AC/DC	NC	088H3130
TWA-L	RAVL	24 V AC/DC	NO	088H3131
TWA-L	RAVL	230 V AC	NC	088H3132
TWA-L	RAVL	230 V AC	NO	088H3133
TWA-K	M30x1.5**	24 V AC/DC	NC	088H3140
TWA-K	M30x1.5**	24 V AC/DC	NO	088H3141
TWA-K	M30x1.5**	230 V AC	NC	088H3142
TWA-K	M30x1.5**	230 V AC	NO	088H3143
TWA-D	RTD	24 V AC/DC	NC	088H3150
TWA-D	RTD	24 V AC/DC	NO	088H3151
TWA-D	RTD	230 V AC	NC	088H3152
TWA-D	RTD	230 V AC	NO	088H3153

* With end-switch (end-switch only 24 V~)

** Connection to Heimeier, MNG and Oventrop valves with M30x1.5 connection. Other valves must be verified individually to ensure correct valve closing measurement and valve top geometry (see page 3).

Technical Data

Supply voltage	24 V (Class II (SELV)) and 230 V (3 A pre-fuse)
Max. inrush current	24 V: 350 mA, 230 V: 250 mA
Frequency	50-60 Hz
Running power consumption	2 W
Spindle travel time	~3 min.
Ambient temperature	0-60° C
Enclosure	IP 41
Cable length	1200 mm

Combination overview for Danfoss thermal wax actuator and valves (V) or manifolds (M)										
Valve/ manifold	RA-N (V)	RTD-N (V)	RA-C (V)	RA-FN (V)	RA-G (V)	RTD-G (V)	RAV-/8 (V)	VMT-8 (V)	RAVL-6 (V)	FHD (M)
k_{vs} (m ³ /H)	0.65 to 1.40	0.65 to 1.40	1.20 to 3.30	0.65 to 1.40	2.06 to 4.75	2.00 to 4.40	1.20 to 3.10	1.50 to 3.10	0.20 to 1.50	0.10 to 1.10
Max. Δ (Bar)	0.6	0.6	0.6	0.6	0.2*	0.2*	0.8	0.8	0.6	0.6
Actuator **	TWA-A	TWA-D	TWA-A	TWA-A	TWA-A	TWA-D	TWA-V	TWA-V	TWA-L	TWA-A

* The RA-G/ RTD-G 25 valve has a max. Δp = 0.16 bar. Consult valve/manifold datasheets for further information.

**If the actuator should be an 24 V or 230 V and normally open (NO) or normally closed (NC), depends mainly of the application, control strategy and the controller connected to the actuator.

Electrical Connection

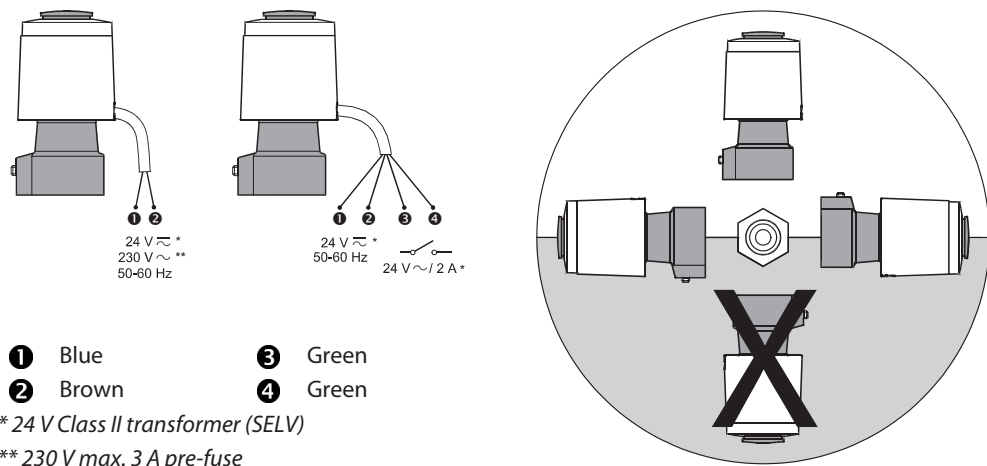

Please note: All NC-versions are equipped with a red mounting split on the position indicator to secure easy valve connection. When mounted this split must be removed for correct operation.

Dimensions

TWA-A / RA valves

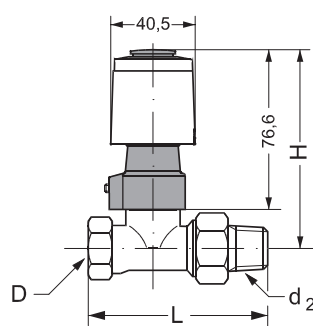

DN	D ISO 7/1	d ₂	Valve type	H, mm	L, mm
10	R _p 3/8	R 3/8	RA-N, RA-FN	92	75
15	R _p 1/2	R 1/2	RA-N, RA-FN	92	82
20	R _p 3/4	R 3/4	RA-N, RA-FN	97	98
25	R _p 1	R 1	RA-N, RA-FN	97	125
15	R _p 1/2	R 1/2	RA-G	95	96
20	R _p 3/4	R 3/4	RA-G	95	107
25	R _p 1	R 1	RA-G	99	125

TWA-V / RAV valves

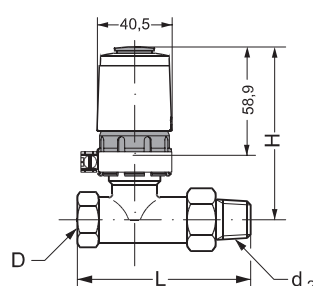

DN	D ISO 7/1	d ₂	RAV	H, mm	L, mm
15	R _p 1/2	R 1/2	15/8	74	95
20	R _p 3/4	R 3/4	20/8	74	106
25	R _p 1	R 1	25/8	87	125

TWA-L / RAVL

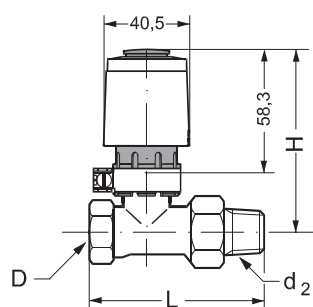

DN	D ISO 7/1	d ₂	RAVL	H, mm	L, mm
10	R _p 3/8	R 3/8	10	75	85
15	R _p 1/2	R 1/2	15	75	95
20	R _p 3/4	R 3/4	20	75	106

TWA-V / VMT

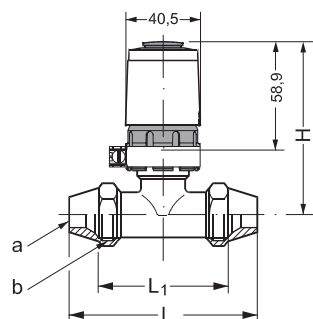

DN	a	b	VMT	H, mm	L, mm
15	Ø15, Ø16, Ø18	G 3/4 A	15/8	74	90
20	Ø18, Ø22	G 1 A	20/8	74	101
25	Ø28	G 1 ¼ A	25/8	87	120

TWA-D / RTD valves

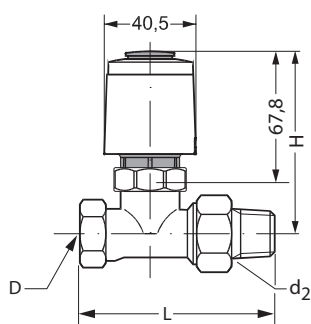

DN	D ISO 7/1	d ₂	Valve type	H, mm	L, mm
10	R _p 3/8	R 3/8	RTD-N	83.2	75
15	R _p 1/2	R 1/2	RTD-N	83.2	82
20	R _p 3/4	R 3/4	RTD-N	88.2	98
25	R _p 1	R 1	RTD-N	88.2	125
15	R _p 1/2	R 1/2	RTD-G	86.2	96
20	R _p 3/4	R 3/4	RTD-G	86.2	107
25	R _p 1	R 1	RTD-G	90.2	125

TWA-K

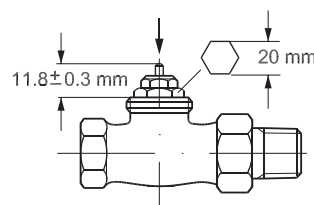
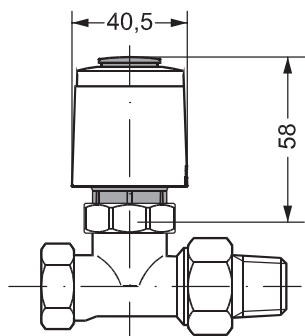

Danfoss A/S
 Heating Solutions
 Haarupvaenget 11
 8600 Silkeborg
 Denmark
 Phone: +45 7488 8000
 Fax: +45 7488 8100
 Email: heating.solutions@danfoss.com
www.heating.danfoss.com

Danfoss can accept no responsibility for possible errors in catalogues, brochures and other printed material. Danfoss reserves the right to alter its products without notice. This also applies to products already on order provided that such alterations can be made without subsequential changes being necessary in specifications already agreed. All trademarks in this material are property of the respective companies. Danfoss Heating Solutions and the Danfoss Heating Solutions logotype are trademarks of Danfoss A/S. All rights reserved.