

JB INDUSTRIES PRODUCT CATALOG



JUST BETTER

VERSION 46



Another year has come and gone, and we now look forward to the New Year with hope and enthusiasm. We hope that the economic recovery will gain strength and blossom into a full, dynamic turnaround erasing the dismal conditions that have plagued the economy over the past few years. Indeed, there are several positive signs indicating progress, including the housing market and employment gains, but we still have other serious problems to resolve such as the deficit and national debt. We are enthusiastic that the diverse American manufacturing base will continue to strengthen and positively impact the economic recovery.

We are again witnessing a migration of more American companies back to the U. S., having recognized the advantages of manufacturing in the U. S. This is being driven by increasing overseas manufacturing costs, shipping and inventory costs, a desire to be closer to their customer base, and wanting to have better control over their technology and quality. As reported in the media, whereas wage costs have been essentially flat in recent years in the U. S., wages in Asia have been increasing and continue to increase. The bottom line is many of the very reasons many companies relocated manufacturing overseas are no longer so attractive. We feel the trend for “Made in America” products will continue and more companies will be bringing their manufacturing back to the U.S. JB’s conscious decision to keep its manufacturing in the U. S. has proven to be the right decision for JB, and you have our commitment that we will continue to be a U. S. based company. We are proud that the “Made in America” motto has always been, and will continue to be, an important part of JB’s company philosophy.

We want to do our part to keep America strong and vibrant. This will require JB to rededicate the company each year to utilize its talented employees and excellent representative/distributor network to provide the highest product quality and support possible, to team with vendors that share our dedication and determination, while at the same time dedicating resources to continue research and development activities to keep JB in a leading position in our industry segment. By doing these things we feel we can best support our customers and grow our market. We have already taken a few steps towards this goal, recognizing two employees for their 40 years of dedicated service to JB, revamping our shipping department to ensure faster turnarounds and increased order accuracy, and completely renovating our social media campaigns which will allow us to connect with our customers on a more personal level, providing them with our latest news and products.

During this coming year, JB will be finalizing designs on a number of innovative products. As each product is announced we will provide information for your review. As with all our existing and new product designs we welcome your comments, both positive and negative to help us with our efforts to provide you with products that meet and exceed your expectations.

Finally, this is an opportunity to thank our outstanding customers for their business and loyalty. We never lose sight of the facts that we are in business for you and because of you. We are committed to producing products and to provide support of the highest quality possible, and to continue to search for innovative solutions to meet your needs. It is truly a privilege to serve and work with you. It is our sincere wishes that 2013 will prove to be a healthy, prosperous, and successful year for all.

Jeff Cherif - President

TABLE OF CONTENTS

DEEP VACUUM

Platinum® Pumps	4-5
Eliminator® Pumps	6-7
Vacuum Pump Accessories	8-9
Digital Micron Gauges	10-11

CHARGING EQUIPMENT 12-32

Prowler Leak Detector	12-13
Atlas Refrigeration Scale	14
Superheat/Subcooling Gauge	16
Charging/Testing Methods	17
M2 Brass Manifold	18-19
2-Valve Zeppelin® Manifolds	20-23
Revolver Ball Valve Manifold	24-25
4-Valve Zeppelin® Manifolds	25-27
M4 Brass Manifold	28
Heat Pump Manifold	29
Metric Manifolds	30-32

GAUGES 33-37

Standard Replacement 2-1/2"	33
3-1/8" And 4" Gauges	34-35
Manifold Accessories	36
Gauge Boots And Accessories	36-37

HOSES 38-42

Kobra® High Pressure Hose	38-42
1/4", 3/8", 1/2" Heavy Duty Hose	42
Metal Hose	42
Standard Hose	42

ACCESS VALVES

Access Valves	43-48
Valve Core Tools	49
Caps	50
Novent Locking Caps	51
Quick Couplers	52
Automotive Couplers	53
Ball Refrigeration	54-55

TOOLS AND ACCESSORIES 51-62

Rothenberger Tools	56-63
Wrenches	62
Capillary Tools	63-64
LA-CO Products	65

BRASS FITTINGS 66-71

WARRANTY 72-73

MARKETING 74-75

REPAIR PARTS 76-81

Deep Vacuum Pumps	76-78
Manifold Repair Parts	79-81

INDEX 82-85

SALES AGENTS 86-87

PLATINUM

GAS BALLAST EXTENDS THE LIFE OF THE PUMP BY KEEPING THE OIL CLEANER

2 STAGE DIRECT DRIVE TO ACHIEVE DEEP 15 MICRON VACUUM

AVAILABLE DOMESTIC 115 VOLT, INTERNATIONAL 230 VOLT, AND DUAL VOLTAGE

CHECK VALVE PREVENTS OIL BACK FLOW DURING POWER FAILURE

LOW PROFILE ROCKER SWITCH

TETHERED SAFETY CAP PREVENTS OIL SPILLS DURING TRANSPORT

1/2" NPT BREAK RESISTANT HANDLE ENCOMPASSES EXHAUST

LIGHTER WEIGHT FINNED ALUMINUM HOUSING REDUCES HEAT DURING OPERATION

WELL-PROTECTED DRAIN VALVE SEALED WITH O-RING TO PREVENT LEAKS

1/2 HP CAPACITOR START MOTOR WITH THERMAL OVERLOAD PROTECTION

ALL METAL CONSTRUCTION INCLUDING ALL BRASS FITTINGS

100% FIELD REPAIRABLE

24 MONTH WARRANTY



Backed by an unprecedented **24 month over-the-counter warranty, there is no better pump on the market. Because each PLATINUM® pump is made at our facility in Aurora, Illinois, quality and dependability are woven in with hard working American pride. Completely field repairable, our PLATINUM® series is designed to last. Turn to page 76 for a complete list of repair parts.

VACUUM RATING
15 MICRON RATING

FIELD REPAIRABLE
100%

JB WARRANTY
24 MONTHS

PLATINUM® PREMIUM SERIES VACUUM PUMPS

BEST PUMP IN THE INDUSTRY

JB Industries' PLATINUM® series vacuum pump is the best pump in the industry. Designed for the serious air conditioning and refrigeration technician, the PLATINUM® vacuum pump features a gas ballast and blank off valve. American made and subjected to JB's rigorous performance standards, the PLATINUM® Series is the top of the line for both quality and durability. Backed by an unprecedented **24 month over-the-counter warranty, there is no better pump on the market. Because each PLATINUM® pump is made at our facility in Aurora, Illinois, quality and dependability are woven in with hard working American pride. Completely field repairable, our PLATINUM® series is designed to last. Turn to page 76 for a complete list of repair parts.

US DOMESTIC



	DV-42N	DV-85N	DV-142N	DV-200N	DV-285N
CFM	1.5 CFM (42 l/m)	3 CFM (85 l/m)	5 CFM (142 l/m)	7 CFM (200 l/m)	10 CFM (285 l/m)
MOTOR	1/2 HP, 1725 RPM	1/2 HP, 1725 RPM	1/2 HP, 1725 RPM	1/2 HP, 1725 RPM	1/2 HP, 1725 RPM
VOLTAGE	115v, 60Hz	115v, 60Hz	115v, 60Hz	115v, 60Hz	115v, 60Hz
PLUG	Std. U.S. 110v	Std. U.S. 110v	Std. U.S. 110v	Std. U.S. 110v	Std. U.S. 110v
INTAKE PORT	1/4"	1/4" x 3/8"	1/2" x 1/4" x 3/8"	1/2" x 1/4" x 3/8"	1/2" x 1/4" x 3/8"
OIL CAP	26 oz. (798 cc)	26 oz. (798 cc)	21 oz. (680 cc)	21 oz. (680 cc)	26 oz. (709 cc)
SHIP DIMENS.	17-5/8" (h) x 9-1/8" (w) x 14" (l)	17-5/8" (h) x 9-1/8" (w) x 14" (l)	17-5/8" (h) x 9-1/8" (w) x 14" (l)	17-5/8" (h) x 9-1/8" (w) x 14" (l)	17-5/8" (h) x 9-1/8" (w) x 14" (l)
WEIGHT	29 lbs. (13.2 Kg)	30 lbs. (13.6 Kg)	32 lbs. (14.5 Kg)	32 lbs. (14.5 Kg)	34 lbs. (15.4 Kg)

DUAL VOLTAGE

	DV-42N-250	DV-85N-250	DV-142N-250	DV-200N-250	DV-285N-250
MOTOR	1/2 HP 1725/1425 RPM	1/2 HP 1725/1425 RPM	1/2 HP 1725/1425 RPM	1/2 HP 1725/1425 RPM	1/2 HP 1725/1425 RPM
VOLTAGE	115v/60Hz, 230v/50Hz	115v/60Hz, 230v/50Hz	115v/60Hz, 230v/50Hz	115v/60Hz, 230v/50Hz	115v/60Hz, 230v/50Hz
PLUG	Std. U.S. 220v	Std. U.S. 220v	Std. U.S. 220v	Std. U.S. 220v	Std. U.S. 220v

EURO

	DV-42N-250EU	DV-85N-250EU	DV-142N-250EU	DV-200N-250EU	DV-285N-250EU
MOTOR	1/2 HP, 1425 RPM	1/2 HP, 1425 RPM	1/2 HP, 1425 RPM	1/2 HP, 1425 RPM	1/2 HP, 1425 RPM
VOLTAGE	230v, 50Hz	230v, 50Hz	230v, 50Hz	230v, 50Hz	230v, 50Hz
PLUG	Euro	Euro	Euro	Euro	Euro

UNITED KINGDOM

	DV-42N-250UK	DV-85N-250UK	DV-142N-250UK	DV-200N-250UK	DV-285N-250UK
MOTOR	1/2 HP, 1425 RPM	1/2 HP, 1425 RPM	1/2 HP, 1425 RPM	1/2 HP, 1425 RPM	1/2 HP, 1425 RPM
VOLTAGE	230v, 50Hz	230v, 50Hz	230v, 50Hz	230v, 50Hz	230v, 50Hz
PLUG	UK	UK	UK	UK	UK

To check vacuum accurately, use the new DV-40 SUPERNOVA or the DV-22N (see pages 10 & 11).

*One Micron On A U-Tube Manometer. 25,400 Microns = 1"

Operating instructions available on our web site at www.jbind.com

**Subject to warranty as set forth on page 73 and warranty and terms and conditions of sales set forth at www.jbind.com

ELIMINATOR

LARGE, EASY-TO-SEE
SIGHT GLASS ENSURES
PROPER OIL LEVEL

OIL FILL IS NOW ISOLATED ON COVER
FOR EASY FILL

INCREASED SPACING BETWEEN
INTAKE TEE AND HANDLE
FOR MORE ROOM

LARGER 1/2" HANDLE NOW
MORE ERGONOMIC

TETHERED SAFETY CAP PREVENTS
OIL SPILLS DURING TRANSPORT

1/2 HP CAPACITOR START MOTOR
WITH THERMAL OVERLOAD
PROTECTION

NEW HEAVY DUTY
HAMMERTONE PAINT COLOR

INCREASED OIL CAPACITY FOR
COOLER RUNNING TEMPERATURE
AND REDUCED CONTAMINATION

WELL-PROTECTED DRAIN VALVE
SEALED WITH O-RING
TO PREVENT LEAKS

2 STAGE DIRECT DRIVE
TO ACHIEVE DEEP 25
MICRON VACUUM

ALL METAL CONSTRUCTION
INCLUDING ALL BRASS FITTINGS

**24 MONTH
WARRANTY**

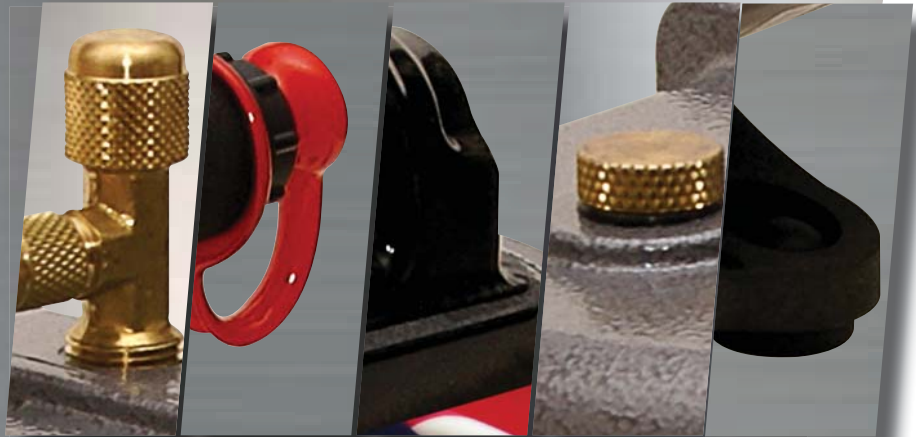

CFM² = Maximum Tonnage Rating. Therefore, take the CFM rating of a pump and multiply it by that number to find the maximum number of tons the pump is rated for. A 3 CFM pump (3 x 3) is rated for 9 tons. A 7 CFM pump (7 x 7) is rated for 49 tons. In many cases, depending on the system line sizes of large tonnage systems, it is better to put two or more smaller, easily maneuverable pumps at different locations. This will overcome some of the pressure drop problems and actually evacuate faster than a single, large pump. Pumps in the 1.5 to 10 CFM class are adequate to handle 99% of the work.

**VACUUM
RATING**
**25 MICRON
RATING**

**FIELD
REPAIRABLE RATING**
100%

**JB
WARRANTY**
**24
MONTH**

ELIMINATOR®

QUALITY SERIES VACUUM PUMPS

THE ONLY AMERICAN MADE ECONOMY PUMP

Built for the Air Conditioning Serviceman who wants a high quality, dependable vacuum pump, the ELIMINATOR® series offers many higher end features without the higher end price. American made, 100% tested to JB's stringent quality standards, backed by an unparalleled **24 month over-the-counter warranty, the ELIMINATOR® is the best economy vacuum pump in the industry. This is the only American made economy vacuum pump on the market and because each ELIMINATOR® is made at our factory in Aurora, Illinois, American pride is built into each one of these workhorses. Completely field repairable, these pumps are built to withstand the toughest jobs. Please refer to page 78 for a complete list of repair parts.

US DOMESTIC

	DV-3E	DV-4E	DV-6E
CFM	3 CFM (85 l/m)	4 CFM (113 l/m)	6 CFM (170 l/m)
MOTOR	1/2 HP, 1725 RPM	1/2 HP, 1725 RPM	1/2 HP, 1725 RPM
VOLTAGE	115v, 60Hz	115v, 60Hz	115v, 60Hz
PLUG	Std. U.S. 110v	Std. U.S. 110v	Std. U.S. 110v
INTAKE PORT	1/4" x 3/8"	1/4" x 3/8"	1/4" x 3/8"
OIL CAP	28 oz. (827 cc)	25 oz. (739cc)	25 oz. (739 cc)
SHIP DIMENS.	17- 5/8" (h) x 9- 1/8" (w) x 14" (l)	17-5/8" (h) x 9-1/8" (w) x 14" (l)	17-5/8" (h) x 9-1/8" (w) x 14" (l)
WEIGHT	29 lbs. (13.1 Kg)	30 lbs. (13.6 Kg)	30 lbs. (13.6 Kg)

DUAL VOLTAGE

	DV-3E-250	DV-4E-250	DV-6E-250
MOTOR	1/2 HP 1725/1425 RPM	1/2 HP 1725/1425 RPM	1/2 HP 1725/1425 RPM
VOLTAGE	115v/230v 50/60Hz	115v/230v 50/60Hz	115v/230v 50/60Hz
PLUG	Std. U.S. 220v	Std. U.S. 220v	Std. U.S. 220v

EURO

	DV-3E-250EU	DV-4E-250EU	DV-6E-250EU
MOTOR	1/2 HP, 1425 RPM	1/2 HP, 1425 RPM	1/2 HP, 1425 RPM
VOLTAGE	230v, 50Hz	230v, 50Hz	230v, 50Hz
PLUG	Euro	Euro	Euro

UNITED KINGDOM

	DV-3E-250UK	DV-4E-250UK	DV-6E-250UK
MOTOR	1/2 HP, 1425 RPM	1/2 HP, 1425 RPM	1/2 HP, 1425 RPM
VOLTAGE	230v, 50Hz	230v, 50Hz	230v, 50Hz
PLUG	Euro	UK	UK

Operating Temperature 150°F +/- 18° F (60° C +/- 10° C)

To check vacuum accurately, use the new DV-40 SUPERNOVA or the DV-22N (see pages 10 & 11).

*One Micron On A U-Tube Manometer. 25,400 Microns = 1"

Operating instructions available on our web site at www.jbind.com

**Subject to warranty as set forth on page 73 and warranty and terms and conditions of sales set forth at www.jbind.com



The last inch of pressure as indicated on the gauge is 25,400 microns.

HOW TO MEASURE EVACUATION

A micron is a unit of pressure starting from a perfect vacuum (no pressure) expressed in linear increments. One inch equals 25,400 microns. That last inch of pressure below zero on the low side compound gauge (see illustration) is 25,400 microns. A compound gauge only indicates that a vacuum is being produced, but does not tell you if moisture or contaminants are still in the system. Evacuation is complete when a system holds 500 microns to ensure dehydration is complete. Therefore, there is a small fraction of an inch difference between a complete evacuation and an inadequately evacuated system. A compound gauge cannot measure this pressure at these levels accurately. Only a micron gauge like the new SUPERNOVA DV-40 or our DV-22 (refer to pages 10 and 11) can accurately read the low pressures produced when evacuation/dehydration is complete.

DEEP VACUUM PUMP ACCESSORIES

THE TANK VACUUM PUMP OIL CADDY

NEW!



The TANK Extends the life of your vacuum pump! All vacuum pumps require changing oil after every use. Contaminated oil, laden with moisture and acid will damage pumps and shorten pump life. On top of that, deep vacuums cannot be achieved with contaminated oil. Maintaining clean oil in the pump ensures that your pump will operate at peak efficiency.

Change your vacuum pump oil in between jobs

No more mess and spills, easy and convenient

Extends the life of your vacuum pump

PART NO.	DESCRIPTION
DV-T1	Vacuum pump oil caddy

BEST OIL IN THE INDUSTRY



Black Gold Vacuum Pump Oil is the gold standard in vacuum pump care. For use in any vacuum pump, Black Gold is extremely pure and non-detergent. Our Black Gold is hydro processed which means it goes through a series of catalytic steps rendering the oil extremely refined, more viscous, and more stable. The result is clear mineral oil which will alert you to contamination sooner as it becomes cloudy or milky. In extreme temperatures, the oil will be more resistant to contaminants. We still recommend, however, that the oil be changed after every evacuation for maximum performance and pump efficiency.

The best test to see if your oil is contaminated is through a micron gauge. With a leak-free system, if your DV-22N micron gauge is still not reading a deep vacuum, the oil is too contaminated and should be changed. If the micron gauge pulls down to about 50 microns the oil is good. Viscosity is a measure of the weight of the oil. For industrial oil, the viscosity is an ISO grading at 40°C. Black Gold vacuum pump oil is an ISO 41, a special to this type of application.

PART NO.	DESCRIPTION	CTN. QTY.	SHIPPING WEIGHT	CARTON DIMENS.
DVO-1	Pint Bottle	24	25 Lbs /11.4 kg	9" x 14-1/4" x 12-1/2"
DVO-12	Quart Bottle	12	24 Lbs /10.9 kg	11" x 13" x 10"
DVO-24	Gallon Bottle	6	47 Lbs /21.4 kg	12-1/2" x 15-1/2" x 12-1/2"

FLEXIBLE METAL LINE

Unlike charging hoses, our flexible metal lines will not permeate under vacuum. Our metal lines feature finger-tight O-ring coupler ends.

PART NO.	DESCRIPTION
D10436	1/4" x 36" flexible metal line (one 45° fitting)
D10472	1/4" x 72" flexible metal line (one 45° fitting)
D10636	3/8" x 36" flexible metal line (one 45° fitting)
D10660	3/8" x 60" flexible metal line (one 45° fitting)
DV-294	1/4" x 10" flexible metal line (straight fittings)
P90009	1/4" replacement O-ring (10 pack)
P90012	3/8" replacement O-ring (10 pack)



DEEP VACUUM PUMP ACCESSORIES

OIL MIST FILTER

Eliminates oil mist from pump handle. DV-F8 fits 1/2" exhaust pipe in 2008+ model Platinums and 2011+ Eliminators, while DV-F6 fits 3/8" exhaust pipe for all pre-2011 Eliminator® series and pre-2008 model Platinums.



DV-F8

PART NO.	DESCRIPTION
DV-F6	Oil mist filter 3/8"
DV-F8	Oil mist filter 1/2"

ECONOMY DEEP VACUUM MANIFOLD D10053



Ideal for use in domestic service, the deep vacuum manifold features separate valves for isolating the system from the pump and charging and/or performing pressure drop tests. The manifold can be hooked up for charging, to a micron gauge, and to charging hoses as well as quickly connecting to a pump with a 3/8" intake port. Use P90018 as replacement O-rings.



D10053

BLANK-OFF MANIFOLD VALVE D10160



Blank-off manifold valves isolate the pump from the system. These are designed and necessary for all pumps without an internal blank-off valve like the Eliminator®. The 3/8" QC connects to the center manifold port, the 3/8" SAE flare port is for the hose connection from the pump, and the 1/4" ports are for the refrigerant line and the micron gauge.

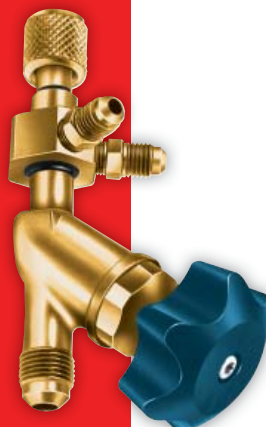

D10160

SWIVEL COUPLERS

Features an O-ring Seal.



D10244

PART NO.	DESCRIPTION
D10244	1/4" female swivel coupler
D10266	3/8" female swivel coupler
P90009	1/4" replacement O-ring (10 pack)
P90012	3/8" replacement O-ring (10 pack)

SHUT OFF VALVE

Our O-ring quick coupler valves are great for blanking off any vacuum system and work for pressures up to 800 lbs.



D10162

PART NO.	DESCRIPTION
D10162	1/4" Fe QC x 1/4" flare

QUICK COUPLERS

Features an O-ring seal and no depressor. Please refer to page 52 for a complete list of elbow, straight, and FTP thread couplers and valves.



QC-E64

PART NO.	DESCRIPTION
QC-E64	3/8" QC x 1/4" SAE elbow
QC-S64	3/8" QC x 1/4" SAE straight
P90009	1/4" replacement O-ring (10 pack)
P90012	3/8" replacement O-ring (10 pack)

TETHERED SAFETY CAP

Designed to prevent oil spills during transport. 3/8" fits pre-2008 Platinums and pre-2011 Eliminators.



PART NO.	DESCRIPTION
DV-EP6	Tethered cap 3/8"
DV-EP8	Tethered cap 1/2"

DV-41

FACTORY CALIBRATED AND REQUIRES
NO ADDITIONAL CALIBRATION

MEASURES IN MICRONS, PSIA, INHG,
PASCALS, TORR, MTORR, AND MBAR

IF SENSOR GETS CONTAMINATED,
CLEAN WITH SIMPLE ALCOHOL

PROGRAMMABLE ALARM
ALLOWS YOU TO PERFORM
OTHER TASKS

DURATION OF BACKLIGHT
IS PROGRAMMABLE

BRASS FITTING ON LENGTHY FLEX-
IBLE CORD FOR HARD TO REACH
PLACES

PROGRAMMABLE SHUT-OFF

LARGE, EASY TO READ LCD SCREEN

THE FEMALE CONNECTION ON THIS
UNIT ALLOWS FOR DIRECT
CONNECTION TO THE A/C UNIT
WITHOUT NEED OF HOSE
CONNECTION. JB DOES NOT
RECOMMEND CONNECTION
THROUGH A HOSE AS IT
NEGATIVELY AFFECTS
ACCURACY.

OPERATES ON 3 AA BATTERIES
(NOT INCLUDED)



**12 MONTH
WARRANTY**

SUPERNOVA

DV-41 DIGITAL MICRON GAUGE

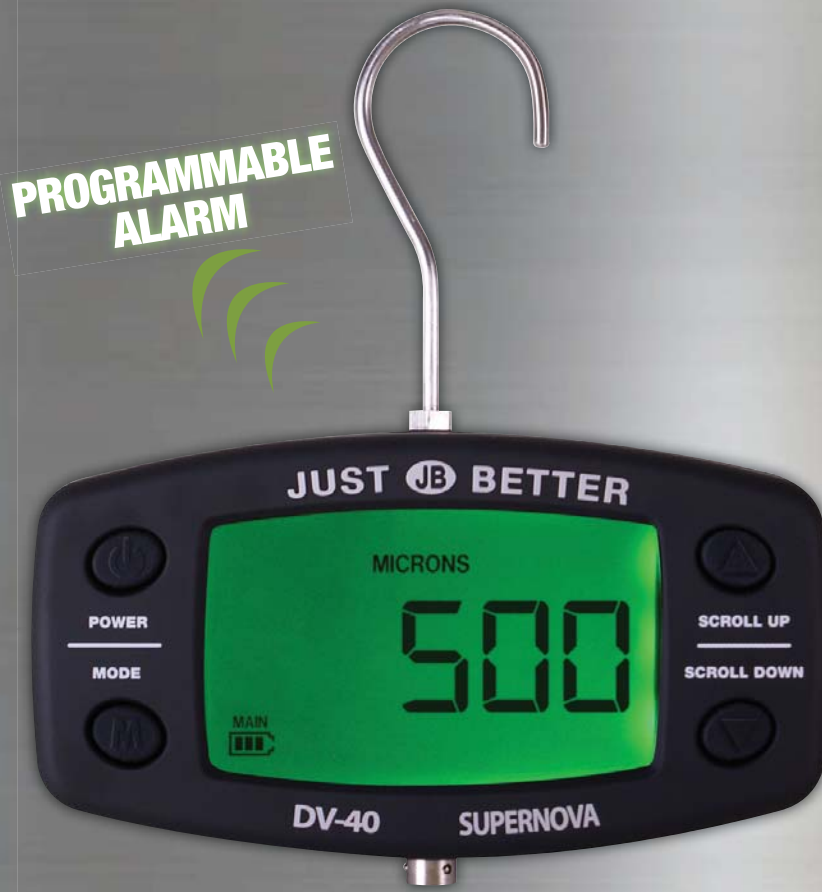

INNOVATION AT ITS BEST

JB Industries' SUPERNOVA gauge allows a service technician to be certain when a system is properly evacuated of air and moisture before charging with refrigerant. The SUPERNOVA is accurate from 12,000 microns down to 10 microns. The unit features many user-defined programmable options such as duration of the backlight, programmed shut-off, and the ability to set alarms when system reaches defined mark. The service technician can customize the SUPERNOVA to fit work habits. Make service calls more efficient without sacrificing quality. The SUPERNOVA has been named a Bronze winner for the 2009 Dealer Design in tools.

PART NO.	DESCRIPTION
DV-40	Hand held digital vacuum gauge
DV-41	DV-40 with protective carrying case and AC adapter
DV-40C	Protective carrying case and adapter only
DV-40AC	A/C Adapter (NOT A BATTERY CHARGER)
DV-40HK	Replacement hanging hook
A34000D	1/4" QC x 1/4" access tee (with depressor)
P90009	Replacement O-ring (10 pack)

*The DV-40 is not recommended for connection to vacuum pump when blanking off isolation valve. The preferred hook-up uses the DV-29 when the blank-off valve is engaged as illustrated on page 16.

DIGITAL MICRON GAUGE



DV-22N DIGITAL MICRON GAUGE

JB's DV-22 reads vacuum in 7 international units: Microns, PSIA, InHg, mBars, Pascals, Torr, and mTorr. The DV-22 has a micron range of 20 to 9,000 microns. It is a good idea to attach the micron gauge to the vacuum pump before evacuation to make sure the pump pulls down to at least 50 microns. If it doesn't, your pump oil is contaminated and should be changed. A compound gauge only indicates that a vacuum is being produced, but does not tell you if moisture and acids are still present in the system. Micron gauges are the only tool to accurately read the low pressure produced when evacuation/dehydration is complete. Refer to page 7 under "How to Measure Evacuation" for more information.

PART NO.	DESCRIPTION
DV-22N	Hand held digital vacuum gauge
DV-24N	DV-22N with protective carrying case
DV-26N	Protective carrying case only
DV-18	A/C Adapter
P90009	1/4" replacement O-ring (10 pack)
A34000D	1/4" QC x 1/4" access tee (w/ depressor)
T2-4	1/4" SAE flare tee

*The DV-22N is not recommended for connection to vacuum pump when blanking off isolation valve. The preferred hook-up uses the DV-29 when the blank-off valve is engaged as illustrated on page 16.

DV-22N

EFFECTIVE RANGE 20-9,000 MICRONS

LOW BATTERY INDICATOR ALERTS TO REPLACING 9-VOLT BATTERY (NOT INCLUDED)

SAVES LAST VACUUM READOUT AFTER SHUT-DOWN

POWERS OFF AFTER 10 MINUTES OF NO USE TO PRESERVE BATTERY LIFE

+32°F TO 120°F +0°C TO 48.9°C AMBIENT TEMPERATURE

NIST TRACEABLE

THE FEMALE CONNECTION ON THIS UNIT ALLOWS FOR DIRECT CONNECTION TO THE A/C UNIT WITHOUT NEED OF HOSE CONNECTION. JB DOES NOT RECOMMEND CONNECTION THROUGH A HOSE AS IT NEGATIVELY AFFECTS ACCURACY.

DIGITAL DISPLAY WITH SOLID STATE CIRCUITRY AUTOMATICALLY ADJUSTS FOR FLUCTUATING TEMPERATURE

T2-4 FLARE TEE USED TO ATTACH HOSES TO GAUGE. SOLD AS AN ACCESSORY. PLEASE SEE NOTE ABOVE.

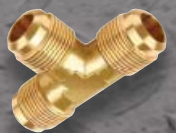

12 MONTH WARRANTY

PROWLER

SENSITIVITY CAN BE PROGRAMMED TO HIGH, MEDIUM, LOW

AUDIBLE ALARM CAN BE MUTED

OPERATES ON 4 AA BATTERIES FOR 10 CONTINUOUS HOURS

BACKLIT LCD SCREEN TILTS UPWARD FOR EASY VIEWING AT ANY ANGLE

AUTOMATIC ZERO

ALERTS TO LEAK THROUGH VIBRATING HANDLE, AUDIBLE ALARM, AND BAR GRAPH

WARM UP TIME < 30 SECONDS AND RESPONSE TIME IS IMMEDIATE

SAFE TO USE IN COMBUSTIBLE ATMOSPHERE

17" FLEXIBLE PROBE

ELECTROCHEMICAL SENSOR LIFE TESTED TO BE GREATER THAN 10 YEARS

BAR GRAPH SHOWS INTENSITY OF LEAK

**24 MONTH
WARRANTY**



HIGHLY SENSITIVE AND ACCURATE FOR ALL HFC, HCFC, BLENDS, AND HFO REFRIGERANTS INCLUDING BUT NOT LIMITED TO :

R-410A	0.05 oz/yr	R-427A	0.05 oz/yr
R-407A	0.05 oz/yr	R-22	0.025 oz/yr
R-1234yf	0.0125 oz/yr	R-134A	0.05 oz/yr
R-404A	0.05 oz/yr		

**CERTIFICATIONS INCLUDE:
CE - EN 14624 - SAE J2791**

PROWLER LD-5000 REFRIGERANT LEAK DETECTOR

JB Industries is proud of our revolutionary LD 5000 PROWLER refrigerant gas leak detector. Using our proprietary JB Electrochemical sensor technology for unparalleled accuracy coupled with the unique user features; there simply is no better hand held probe type service leak detector system on the market. The sensor is durable and will not be damaged by overexposure to refrigerant gas or contaminated by condensate water. Its slim-line design makes it easy to probe difficult to search areas. The sensitivity is extremely accurate for all HFC, HCFC and blended refrigerants as well as the new HFO refrigerants. The technology provides for low battery consumption, excellent circuit stability, extremely long sensor life, and the electrochemical function of the sensor does not diminish over time with use. The sensor life has been tested to be greater than ten years, which is unique in the industry, and it is safe to use in a combustible atmosphere. The PROWLER features a large LCD screen that flips upward so that the user can adjust the screen position for better visibility. The bar graph shows the intensity of a leak to help pinpoint the source of the leak. The sensitivity can be programmed from high to medium to low. If a leak is detected, there is an audible alarm that will sound, vibration in handle, and bar graph on the screen. The LCD display also indicates the amount of remaining battery life. The PROWLER does not require rechargeable batteries. Operates on 4 AA batteries (included).



FEATURES INCLUDE:

- **EXTREMELY ACCURATE FOR ALL HFC, HCFC AND BLENDED REFRIGERANTS AS WELL AS NEW HFO REFRIGERANTS**
- **LEAK INDICATOR BAR GRAPH, AUDIBLE ALERT, AND VIBRATION IN HANDLE**
- **SENSOR LIFE TESTED TO BE GREATER THAN 10 YEARS, UNIQUE IN INDUSTRY**
- **SAFE TO USE IN COMBUSTIBLE ATMOSPHERE**
- **LOW BATTERY CONSUMPTION, EXCELLENT CIRCUIT STABILITY, EXTREMELY LONG SENSOR LIFE, AND ELECTROCHEMICAL FUNCTION OF SENSOR DOES NOT DIMINISH OVER TIME OR WITH USE**
- **SENSITIVITY CAN BE PROGRAMMED TO HIGH, MEDIUM, LOW**
- **AUDIBLE ALARM CAN BE MUTED**

PART NO.	DESCRIPTION
LD-5000	Prowler leak detector in case
LD-S100	Replacement sensor (4 prong)
LD-S101	Replacement sensor (6 prong)
LD-RF5	Replacement filters (5 pack)
LD-TV	Replacement leak test vial
LD-PK	Parts kit (sensor, filter kit, test vial)
LD-CS	Carrying case

* R-1234yf is a replacement for all HFC (134a) and HCFC (R22) refrigerants that are currently being phased out. It is an A2L flammable refrigerant as defined by ASHRAE 34.

ATLAS

SOLID STATE LOAD CELL ACCURATE TO 0.25 OZ/ 10 GM WITHOUT NEED OF CYLINDER DIRECTLY ON CENTER OF WEIGHING PLATFORM

LCD SCREEN ON HANDHELD CAN BE READ FROM A DISTANCE OR IN DIRECT SUNLIGHT

220 LB (100 KG) CAPACITY

PIECES ARE MODULARIZED SO PARTS ARE EASILY REPLACED WITHOUT NEED TO PURCHASE ENTIRELY NEW UNIT

DISPLAYS WEIGHT IN DECIMAL POUNDS, POUNDS & OUNCES, AND KILOGRAMS

AUTO SHUT OFF AFTER 30 MINUTES TO PRESERVE BATTERY AND CAN BE DISABLED

OPTIONAL CHARGING MODULE (DS-MOD) TURNS THE ATLAS INTO A CHARGING STATION WITHOUT THE CYLINDER EVER LEAVING THE WEIGHING PLATFORM. TRANSFERS UP TO 999 POUNDS IN CHARGING INCREMENTS OF 0.25 OZ (10GM). CONNECTION IS A 1/4" FLARE.



24 MONTH WARRANTY

ATLAS REFRIGERANT CHARGING SCALE



TECHNICAL INFORMATION

USAGE	INDOOR/OUTDOOR NOT WATERPROOF
OPERATING TEMP.	+32°F TO 122°F (0°C TO +50°C)
STORAGE TEMP.	+14°F TO 140°F (-10°C TO +60°C)
HUMIDITY	85% RH @113°F (45°C), NON CONDENSING
ALTITUDE	6500 FEET (2000 METERS)
BATTERY LIFE	APPROXIMATELY 60 HOURS
POLLUTION DEGREE	2
OVER VOLTAGE CATEGORY	2

HEAVYWEIGHT CHAMPION

The JB ATLAS refrigerant charging scale is designed for the HVAC/R industry. Every day users will appreciate the advanced solid state load cell for superior sensitivity (0.25 oz/10 gm) and accuracy. The ATLAS's 220 pound (100 kg) weight capacity, all metal construction, heavy duty plastic storage case, and easy-to-read hand held combine to make the ATLAS the best overall package in the industry. Pound for price our 220 pound scale competes at a 110 pound price. Operates with a 9 volt battery (included).

PART NO.	DESCRIPTION
DS-20000	220 lb weight capacity ATLAS scale
DS-MOD	Charging module
DSR-10	Replacement communication cable
DSR-20	Replacement handheld remote
DSR-30	Replacement weighing platform

SUPERHEAT/SUBCOOLING GAUGE



TECHNICAL INFORMATION

	STANDARD	METRIC
Pressure Disp. Range	29 InHg to 600 psig	(-98 kPa to 4134 kPa)
Temp Display Range	-40° F to 200° F	-40° C to 93° C
Operating Temp	32° F to 176° F	0° C to 80° C
Max. Overpressure	800 psig	5512 kPa

SH-35N SUPERHEAT/SUPERCOOLING GAUGE

Our Superheat and Subcooling Gauge saves high, low, and average values for detailed analysis. The SH-35N's gauges features the pressure/temperatures of 32 of the most common refrigerants. Included with gauge is an A34000 access tee, a 6' (1.8m) dry/wet bulb temperature sensor, and 5 socks in a convenient carrying case.

PART NO.	DESCRIPTION
SH-35N	Superheat/Subcooling gauge (F°) in case
SH-36N	Superheat/Subcooling gauge (C°) in case
A34000	1/4" QC x 1/4" access tee
SH-54	6' (1.8m) temperature sensor
SH-55	Plastic carrying case
SH-56	Socks (5 pack)
SH-51	28' (8.5m) temperature sensor extension
A31992	Replacement plastic 1/4" SAE cap
DV-18	AC adapter
SH-59	Temp clamp

*Refrigerant data source from NIST REFRPRO software and manufacturers data.

SH-35N

32 REFRIGERANTS BUILT-IN

1 AND 24-HOUR MEMORY

SAVES HIGH, LOW, AND AVERAGE VALUES FOR DETAILED ANALYSIS

LOW BATTERY INDICATOR ALERTS REPLACING 9-VOLT BATTERY (NOT INCLUDED)

PULSATION PROOF AND ACCURATE TO ANY ELEVATION UP TO 16,000 FEET WITHOUT ADJUSTMENT FOR USE IN MOST GEOGRAPHICAL APPLICATIONS

SIMPLE TWO-BUTTON OPERATION

DIGITAL DISPLAY WITH SOLID STATE CIRCUITRY AUTOMATICALLY ADJUSTS FOR FLUCTUATING TEMPERATURE

SEALED TOUCH BUTTONS PROTECT AGAINST DIRT AND DUST

SH-35 AND SH-36 REFRIGERANT KEYS FOR PRIOR SH-35 AND SH-36 MODELS WITHOUT THE 32 REFRIGERANTS BUILT-IN

PART NO. °F	PART NO. °C
SK-35N	SK-36N

12 MONTH WARRANTY

SUPERHEAT/SUBCOOLING GAUGES

DV-29 MICRON AND SUPERHEAT GAUGE HOOKUP TEST UNIT

Used in conjunction with our micron gauges DV-40 or DV-22N and our superheat/subcool gauge the SH-35N, the DV-29 ensures a leak proof setup. JB's DV-29 works with all micron gauges and creates a closed system, eliminating any leakage under deep vacuum. The DV-29 eliminates other problems when attaching the micron gauge into the system. If the micron gauge is attached directly to the vacuum pump or with a 3' (91.4 cm) dedicated hose, you will get a lower reading as the gauge is sensing what the pump is doing and not what the pump is doing to the system.

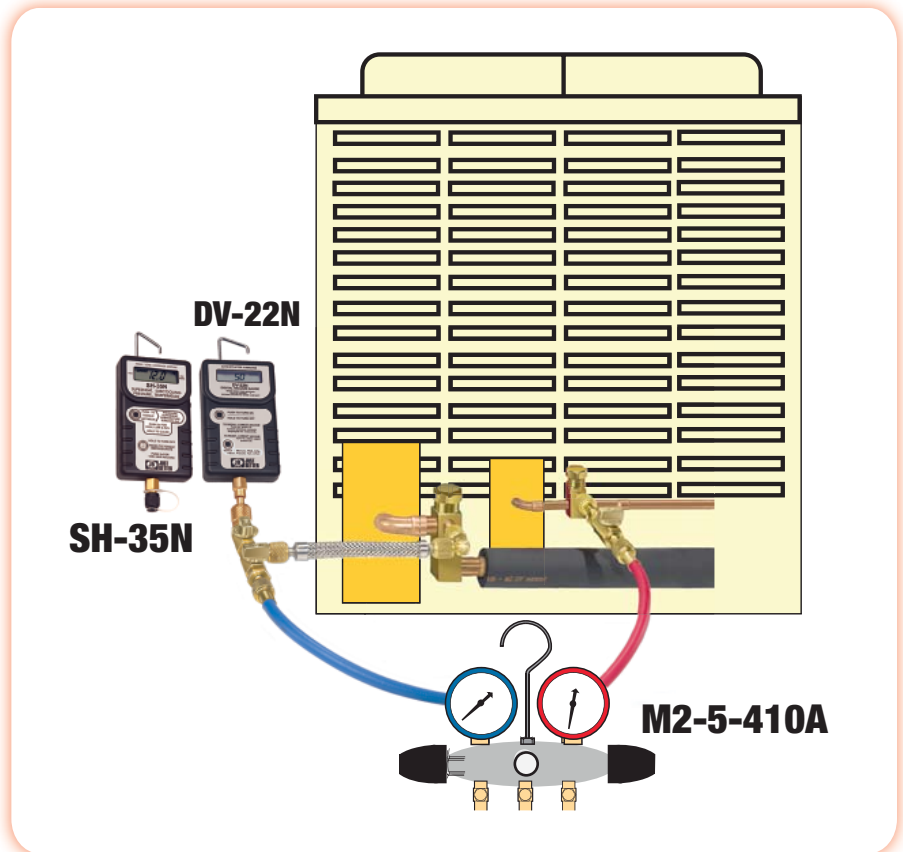
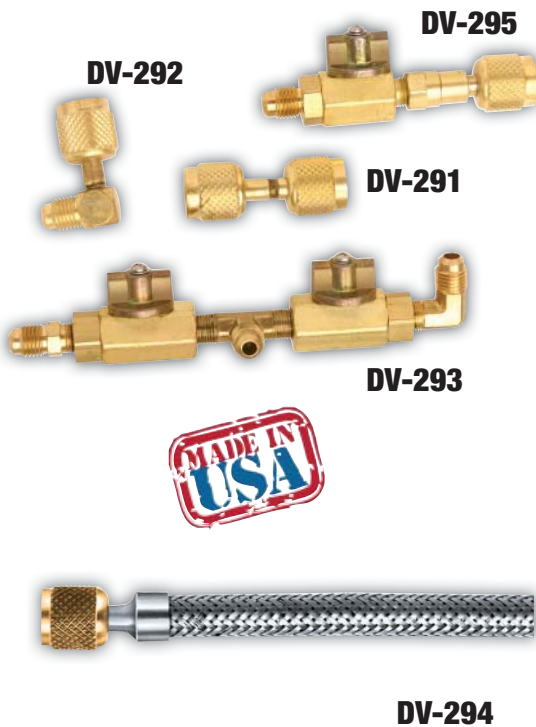

USED IN CONJUNCTION WITH OUR DV-22N AND SH-35N, THE DV-29 ENSURES A LEAK PROOF SETUP. THE DV-29 CONSISTS OF ONE EACH OF THE FOLLOWING:

- **10" (25.4 CM) METAL HOSE WITH O-RING QUICK COUPLERS (DV-294)**
- **90° MALE FLARE WITH 1/4" O-RING QUICK COUPLER (DV-292)**
- **BALL VALVE WITH O-RING QUICK COUPLER WITH DEPRESSOR (DV-295)**
- **VALVE ASSEMBLY WITH 1/4" MALE FLARE CONNECTIONS (DV-293)**

PART NO.	DESCRIPTION
DV-29	Entire hook up system
DV-291	Replacement 1/4" SAE swivel coupler
DV-294	Replacement 10" (25.4 cm) metal hose with O-ring
DV-295	Replacement ball valve with O-ring QC and depressor
DV-292	Replacement 90° male flare with 1/4" O-ring QC
DV-293	Replacement valve assembly 1/4" MFL connector
P90009	Replacement O-ring (10 pack)

CHARGING AND TESTING METHODS

CHARGING METHODS

CHARGING BY SUPERHEAT METHOD

RESIDENTIAL A/C OR REFRIGERATION SYSTEMS EQUIPPED WITH TXV AND RECEIVER, CAPILLARY TUBE, OR METERING DEVICE.

CONTACT MANUFACTURER OR WHOLESALER FOR SUPERHEAT NUMBER.

CHARGING BY SUBCOOLING METHOD

CONTACT MANUFACTURER OR WHOLESALER FOR SUBCOOLING NUMBER.

Average Subcooling value is 10°-12°F.

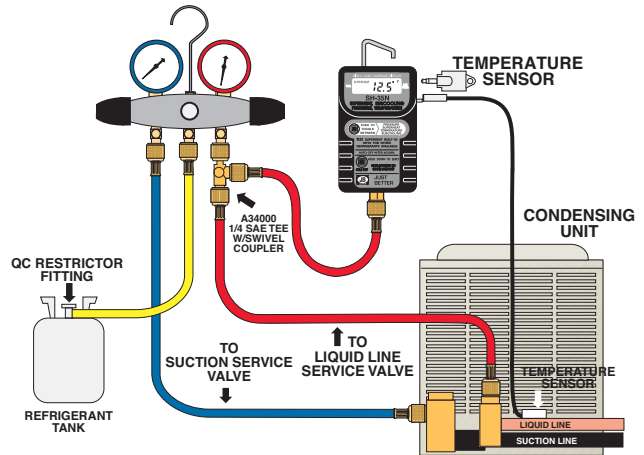
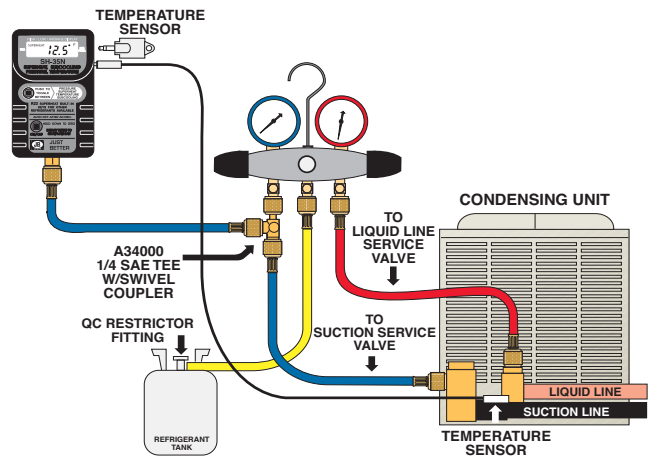

TESTING METHODS

TESTING FOR CHARGE BY SUPERHEAT

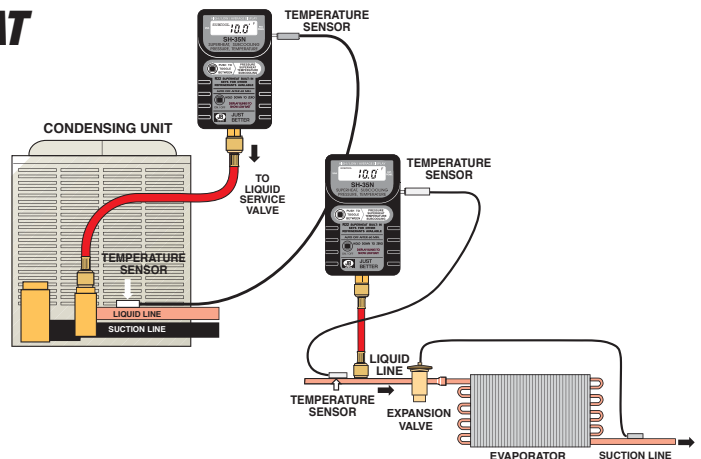
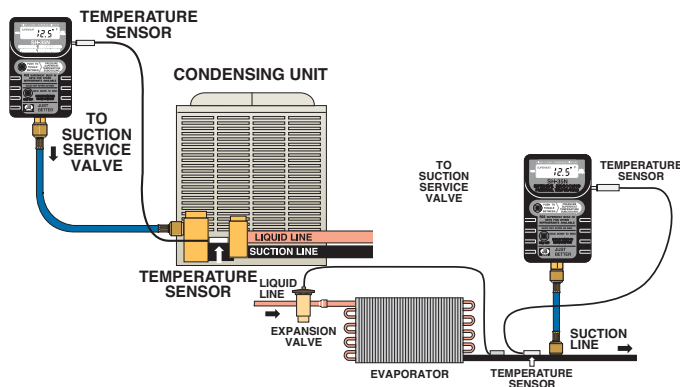

TESTING FOR CHARGE BY SUBCOOLING

*Operating instructions available under Technical Information at www.jbind.com

2-VALVE

SURGE DAMPENED GAUGES FOR REDUCED NEEDLE MOVEMENT

ORIGINAL FREE FLOATING DUAL O-RING SEALING SYSTEM FOR FASTER EVACUATION/CHARGING (SEE BELOW FOR DESCRIPTION)

AVAILABLE WITH 2-1/2" AND 3-1/8" SIZE GAUGES WITH AND WITHOUT BOOTS

ALL METAL GAUGES

COLOR CODED REFRIGERANT DIALS FOR EASY READING

PULL-OUT PROOF HANGING HOOK

REPLACEABLE INTAKE/HOSE HOLDER FITTINGS FOR STORAGE

EASY TURNING PLASTIC HANDWHEELS (METAL AVAILABLE ON SELECT MODELS)

GAUGE BOOTS

MR-590



MR-593



TURN TO PAGE 36 FOR MORE



ORIGINAL FREE FLOATING DUAL O-RING SEALING SYSTEM

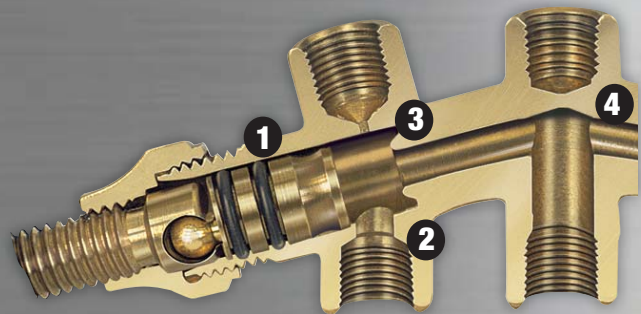

- 1. DOUBLE O-RING**
- 2. STEM SEATS RETRACT COMPLETELY FOR FULL FLOW PATH**
- 3. ZERO LEAKAGE HIGH PRESSURE RAISED SEAT FOR POSITIVE SEATING**
- 4. DOUBLE SIZE FLOW PATH THROUGHOUT LENGTH OF CENTER PORT**

METRIC INFORMATION

OFFERED WITH 63.5 MM (2-1/2") METRIC GAUGES READING BAR/PSI, KPA/PSI, AND KG/CM². FOR INFORMATION ON METRIC VERSIONS, PLEASE REFER TO PAGE 30.

STANDARD BRASS 2-VALVE MANIFOLD

THE INDUSTRY STANDARD

An industry standard for countless years, the JB M2 series of manifolds features our full flow design for faster evacuation/charging. Coupled with an angled bar for better knuckle clearance in rotating the hand wheels, and the original free flowing dual O-ring sealing system, the M2 is the classic American made manifold. All of JB's brass manifolds are equipped with heavy-duty metal gauge cases for added durability.

TO FIND THE RIGHT MANIFOLD

1. CHOOSE THE DESIRED REFRIGERANT COMBINATION
2. SELECT THE HOSE SET THAT SUITS YOUR NEEDS
3. MOVE ACROSS THE CHART TO FIND THE GAUGES AND YOUR MODEL NUMBER

R-12
R-22
R-502

Includes (3) 60" hoses (unless noted)	Standard 2-1/2" gauges	2-1/2" gauges with boots	Glow-in-the-dark 3-1/8" gauges	3-1/8" gauges with 1% accuracy
NO HOSE SET	M2-8	M2-8B	-----	-----
CL 36" RB, 60" Y	M2-6	M2-6B	-----	-----
CCL 60" STANDARD	M2-5	M2-5B	-----	-----
CCL 36" STANDARD	M2-36	M2-36B	-----	-----

R-22
R-134A
R-404A

Includes (3) 60" hoses (unless noted)	Standard 2-1/2" gauges	2-1/2" gauges with boots	Glow-in-the-dark 3-1/8" gauges	3-1/8" gauges with 1% accuracy
NO HOSE SET	M2-21125	M2-21125B	M2-22125	M2-23125
CCL 60" KOBRA® HOSE	M2-21131	M2-21131B	M2-22131	M2-23131

R-22
R-404A
R-410A

Includes (3) 60" hoses (unless noted)	Standard 2-1/2" gauges	2-1/2" gauges with boots	Glow-in-the-dark 3-1/8" gauges	3-1/8" gauges with 1% accuracy
NO HOSE SET	M2-8-410A*	M2-8-410AB	M2-22225	M2-23225
CCL 60" KOBRA® HOSE	M2-5-410A*	M2-5-410AB	M2-22231	M2-23231
CCLS 60" KOBRA® HOSE UL R-410A SECURE SEAL	M2-5-410A-SS	-----	M2-22244	-----

* AVAILABLE WITH SILVER METAL HANDLES, PLEASE ORDER M2-8-410AM AND M2-5-410AM RESPECTIVELY.

R-410A

Includes (3) 60" hoses (unless noted)	Standard 2-1/2" gauges	2-1/2" gauges with boots	Glow-in-the-dark 3-1/8" gauges	3-1/8" gauges with 1% accuracy
NO HOSE SET	M2-21525	M2-21525B	M2-22525	-----
CCL 60" KOBRA® HOSE	M2-21531	M2-21531B	M2-22531	-----

R-427A
R-422B
R-407A

	Standard 2-1/2" gauges	2-1/2" gauges with boots	Glow-in-the-dark 3-1/8" gauges	3-1/8" gauges with 1% accuracy
NO HOSE SET	-----	-----	M2-22325	-----

R-22
R-410A
R-407C

	Standard 2-1/2" gauges	2-1/2" gauges with boots	Glow-in-the-dark 3-1/8" gauges	3-1/8" gauges with 1% accuracy
NO HOSE SET	-----	-----	M2-22425	-----

GAUGE FEATURES AND REPLACEMENTS ARE DETAILED ON PAGE 33-35. GAUGE BOOTS ARE FEATURED ON PAGE 36. METRIC REPLACEMENT GAUGE VERSIONS ARE DETAILED ON PAGE 36. KOBRA® HOSES ARE DETAILED BEGINNING ON PAGE 38. REFER TO "MANIFOLD REPAIR PARTS" BEGINNING ON PAGE 79 FOR ALL JB MANIFOLD REPAIR PARTS. IF YOU DO NOT SEE A REFRIGERANT COMBINATION, PLEASE CONTACT US AT 800-323-0811.

2-VALVE PREMIUM BRASS MANIFOLD

ALL MODELS AVAILABLE WITH AND WITHOUT SIGHT GLASS

SURGE DAMPENED GAUGES FOR REDUCED NEEDLE MOVEMENT

ORIGINAL FREE FLOATING DUAL O-RING SEALING SYSTEM FOR FASTER EVACUATION/CHARGING
SEE PAGE 18 FOR DESCRIPTION

AVAILABLE WITH 2-1/2" AND 3-1/8" SIZE GAUGES

COLOR CODED REFRIGERANT DIALS FOR EASY READING

PULL-OUT PROOF HANGING HOOK

REPLACEABLE INTAKE/HOSE HOLDER FITTINGS FOR STORAGE

HEAVY-DUTY FORGED BRASS BODY IS RUGGED AND DURABLE

SOFT GRIP RUBBER HAND WHEELS REDUCE TURNING TO OPEN/CLOSE

ALL METAL GAUGES



ZEPPELIN



TO FIND THE RIGHT MANIFOLD

- 1. CHOOSE THE DESIRED REFRIGERANT COMBINATION**
- 2. SELECT THE HOSE SET THAT SUITS YOUR NEEDS**
- 3. MOVE ACROSS THE CHART TO FIND THE GAUGES AND YOUR MODEL NUMBER**

2-VALVE PREMIUM BRASS MANIFOLD

The American made ZEPPELIN® series of brass manifolds feature durable molded “soft grip” rubber handles with fingertip grooves that eases opening and closing while the improved stem design means “full open” in only 2½ turns. The brass Zeppelin® series, available only in 2-valve, also incorporates cutting edge styling and technology to significantly reduce the weight of the manifold.

In addition, JB also offers an increased selection of gauges in metal cases and refrigerant combinations. Standard 2-1/2”, large glow-in-the-dark 3-1/8”, and liquid-filled 3-1/8” gauges can be coupled with different refrigerant combinations and JB’s multiple hose options to serve any application. All manifolds include a 60” (152.3 cm) hose set unless noted otherwise.

R-12
R-22
R-502
(Replaces M8 series)

Includes (3) 60” hoses (unless noted)	Standard 2-1/2” gauges	3-1/8” Liquid filled gauges	Glow-in-the-dark 3-1/8” gauges
NO HOSE SET	23000	23050	23025
CCL STANDARD HOSE SET	23004	-----	23029
CCLC KOBRA® HOSE SET	23006	23056	23031*
CCLBV KOBRA® HOSE W/ BALL VALVE	23013	23063	23038
CCLS KOBRA® HOSE W/ UL R-410A SECURE SEAL	23017	23067	23042

*23031 available with sight glass, order 23033

R-22
R-134A
R-404A

Includes (3) 60” hoses (unless noted)	Standard 2-1/2” gauges	3-1/8” Liquid filled gauges	Glow-in-the-dark 3-1/8” gauges
NO HOSE SET	23100	23150	23125
CCLC KOBRA® HOSE SET	23106	23156	23131*
CCLBV KOBRA® HOSE W/ BALL VALVE	23113	23163	23138
CCLS KOBRA® HOSE W/ UL R-410A SECURE SEAL	23117	23167	23142

*23131 available with sight glass, order 23133

R-22
R-404A
R-410A

Includes (3) 60” hoses (unless noted)	Standard 2-1/2” gauges	3-1/8” Liquid filled gauges	Glow-in-the-dark 3-1/8” gauges
NO HOSE SET	23200	23250	23225
CCLC KOBRA® HOSE SET	23206	23256	23231*
CCLBV KOBRA® HOSE W/ BALL VALVE	23213	23263	23238
CCLS 60" KOBRA® HOSE W/ UL R-410A SECURE SEAL	-----	23244	-----

*23231 available with sight glass, order 23233

R-134A
R-404A
R-507
(Replaces M5 series)

Includes (3) 60” hoses (unless noted)	Standard 2-1/2” gauges	3-1/8” Liquid filled gauges	Glow-in-the-dark 3-1/8” gauges
NO HOSE SET	23300	-----	23325
CCLC KOBRA® HOSE SET	23306	-----	23331
CCLBV KOBRA® HOSE W/ BALL VALVE	23313	-----	23338
CCLS KOBRA® HOSE W/ UL R-410A SECURE SEAL	23317	-----	23342

R-410A
(Replaces M7 series)

Includes (3) 60” hoses (unless noted)	Standard 2-1/2” gauges	3-1/8” Liquid filled gauges	Glow-in-the-dark 3-1/8” gauges
NO HOSE SET	23500	-----	23525
1/4” & 5/16” CCLC KOBRA® HOSE SET	23510	-----	23535
CCLC KOBRA® HOSE SET	23506	-----	23531*
CCLBV KOBRA® HOSE W/ BALL VALVE	23513	-----	23538*
CCLV KOBRA® HOSE W/ WHIP END	23521	-----	23546

*23531 available with sight glass, order 23533

*23238 available with sight glass, order 23540

GAUGE FEATURES AND REPLACEMENTS ARE DETAILED ON PAGE 33-35. GAUGE BOOTS ARE FEATURED ON PAGE 36. KOBRA® HOSES ARE DETAILED BEGINNING ON PAGE 38. REFER TO “MANIFOLD REPAIR PARTS” BEGINNING ON PAGE 79 FOR ALL JB MANIFOLD REPAIR PARTS. IF YOU DO NOT SEE A REFRIGERANT COMBINATION, PLEASE CONTACT US AT 800-323-0811.

2-VALVE PREMIUM ALUMINUM MANIFOLD

SURGE DAMPENED GAUGES FOR REDUCED NEEDLE MOVEMENT

ORIGINAL FREE FLOATING DUAL O-RING SEALING SYSTEM FOR FASTER EVACUATION AND CHARGING
(SEE PAGE 18 FOR DESCRIPTION)

AVAILABLE WITH 2-1/2" AND 3-1/8" SIZE GAUGES

COLOR CODED REFRIGERANT DIALS FOR EASY READING

PULL-OUT PROOF HANGING HOOK

PRECISELY MACHINED ANODIZED ALUMINUM BODY

REPLACEABLE INTAKE/HOSE HOLDER FITTINGS FOR STORAGE

SOFT GRIP RUBBER HAND WHEELS REDUCE TURNING TO OPEN/CLOSE

ALL METAL GAUGES



ZEPPELIN 1/4" ALUMINUM 2-VALVE ZEPPELIN®



24225

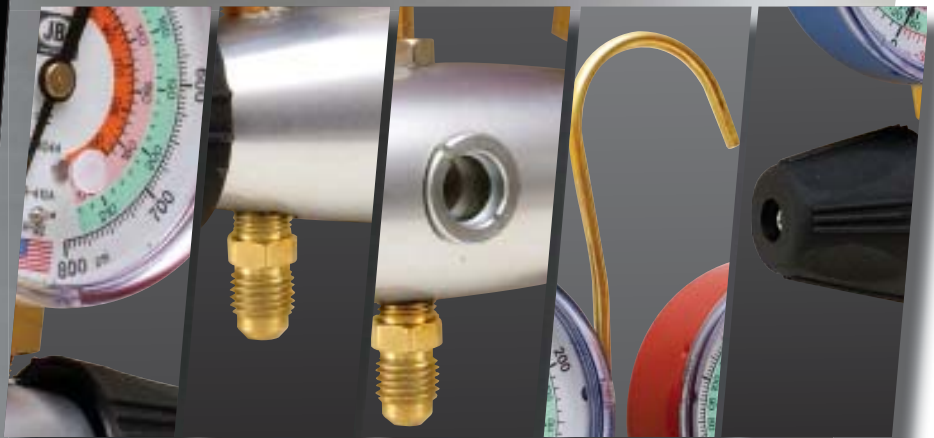

TO FIND THE RIGHT MANIFOLD

1. CHOOSE THE DESIRED REFRIGERANT COMBINATION
2. SELECT THE HOSE SET THAT SUITS YOUR NEEDS
3. MOVE ACROSS THE CHART TO FIND THE GAUGES AND YOUR MODEL NUMBER

METRIC INFORMATION

OFFERED WITH 63.5 MM (2-1/2") METRIC GAUGES READING BAR/PSI, KPA/PSI, AND KG/CM². FOR INFORMATION ON METRIC VERSIONS, PLEASE REFER TO PAGE 31.

2-VALVE PREMIUM ALUMINUM MANIFOLD

The American made aluminum ZEPPELIN® series of manifolds feature durable molded “soft grip” rubber handles with fingertip grooves that ease opening and closing while the improved stem design means “full open” in only 2½ turns. The aluminum ZEPPELIN® series, available in 2-valve and 4-valve, also incorporates cutting edge styling and technology to significantly reduce the weight of the manifold.

In addition, JB also offers an increased selection of gauges in metal cases and refrigerant combinations. Standard 2-1/2”, large glow-in-the-dark 3-1/8”, and liquid-filled 3-1/8” gauges can be coupled with different refrigerant combinations and JB’s multiple hose options to serve any application. All manifolds include a 60” (152.3 Cm) hose set unless noted otherwise.

	Includes (3) 60” hoses (unless noted)	Standard 2-1/2” gauges	3-1/8” Liquid filled gauges	Glow-in-the-dark 3-1/8” gauges
R-12	NO HOSE SET	24000	24050	24025
R-22	CCLC KOBRA® HOSE SET	24008	24058	24033
R-502	CCLBV KOBRA® HOSE W/ BALL VALVE	-----	24065	24040
	CCLS KOBRA® HOSE W/ UL R-410A SECURE SEAL	-----	24069	24044

	Includes (3) 60” hoses (unless noted)	Standard 2-1/2” gauges	3-1/8” Liquid filled gauges	Glow-in-the-dark 3-1/8” gauges
R-22	NO HOSE SET	24100	24150	24125
R-134A	CCLC KOBRA® HOSE SET	24108	24158	24133
R-404A	CCLBV KOBRA® HOSE W/ BALL VALVE	-----	24165	24140
	CCLS KOBRA® HOSE W/ UL R-410A SECURE SEAL	-----	24169	24144

	Includes (3) 60” hoses (unless noted)	Standard 2-1/2” gauges	3-1/8” Liquid filled gauges	Glow-in-the-dark 3-1/8” gauges
R-22	NO HOSE SET	24200	24250	24225
R-404A	CCLC KOBRA® HOSE SET	24208	24258	24233
R-410A	CCLV KOBRA® HOSE W/ WHIP END	-----	24265	24240
	CCLS KOBRA® HOSE W/ UL R-410A	-----	-----	24244

GAUGES DO NOT ILLUMINATE.

	Includes (3) 60” hoses (unless noted)	Standard 2-1/2” gauges	3-1/8” Liquid filled gauges	Glow-in-the-dark 3-1/8” gauges
R-410A	NO HOSE SET	24500	-----	24525
	CCLC KOBRA® HOSE SET	24508	-----	24533

	Includes (3) 60” hoses (unless noted)	Standard 2-1/2” gauges	3-1/8” Liquid filled gauges	Glow-in-the-dark 3-1/8” gauges
R-22	NO HOSE SET	-----	24600	-----
R-134A	CCLC KOBRA® HOSE SET	-----	24608	-----
R-404A	CCLBV KOBRA® HOSE W/ BALL VALVE	-----	24615	-----

		Standard 2-1/2” gauges	3-1/8” Liquid filled gauges	Glow-in-the-dark 3-1/8” gauges
R-427A				
R-422B				
R-407A	NO HOSE SET	-----	-----	24325

		Standard 2-1/2” gauges	3-1/8” Liquid filled gauges	Glow-in-the-dark 3-1/8” gauges
R-22				
R-410A				
R-407C	NO HOSE SET	-----	-----	24425

GAUGE FEATURES AND REPLACEMENTS ARE DETAILED ON PAGE 33-35. GAUGE BOOTS ARE FEATURED ON PAGE 36. METRIC REPLACEMENT GAUGE VERSIONS ARE DETAILED ON PAGE 36. KOBRA® HOSES ARE DETAILED BEGINNING ON PAGE 38. REFER TO “MANIFOLD REPAIR PARTS” BEGINNING ON PAGE 79 FOR ALL JB MANIFOLD REPAIR PARTS. IF YOU DO NOT SEE A REFRIGERANT COMBINATION, PLEASE CONTACT US AT 800-323-081.

REVOLVER

METERING BALL VALVE ADJUST
TO DO FINITE OPENINGS FOR
LIQUID CHARGING

1/4 TURN FULL OPEN/CLOSE HANDLE

FOUR INTERNAL BALL VALVES

3/8" PORT FOR FASTER EVACUATION

HOSE HOLDERS SWIVEL TO THE
FRONT AND REAR FOR FLEXIBILITY

PULL-OUT PROOF HANGING HOOK

SOFT GRIP RUBBER HAND WHEELS
REDUCE TURNING TO OPEN/CLOSE

SURGE DAMPENED GAUGES FOR
REDUCED NEEDLE MOVEMENT

ALL METAL GAUGES



REVOLVER 4-VALVE BALL VALVE MANIFOLD



26000

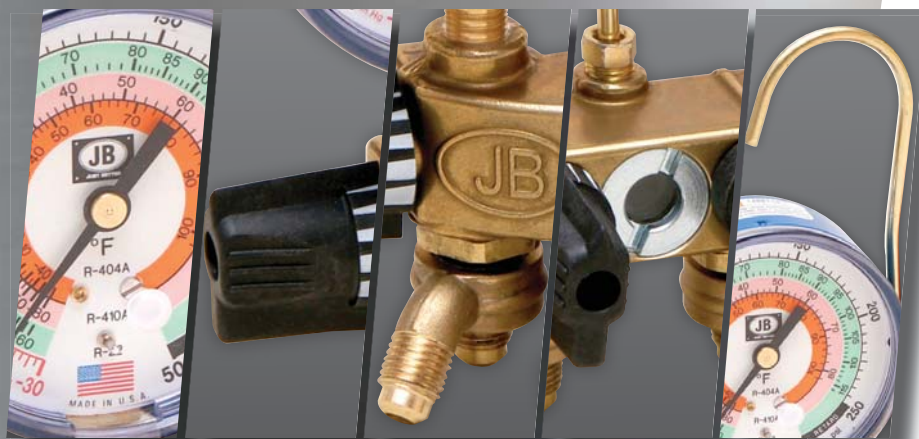

TO FIND THE RIGHT MANIFOLD

- 1. CHOOSE THE DESIRED REFRIGERANT COMBINATION**
- 2. SELECT THE HOSE SET THAT SUITS YOUR NEEDS**
- 3. MOVE ACROSS THE CHART TO FIND THE GAUGES AND YOUR MODEL NUMBER**

4-VALVE BALL VALVE BRASS MANIFOLD

JB introduces the latest addition to our manifold family, the REVOLVER®. Four internal metering ball valves adjust to do finite openings for liquid charging. Sturdy brass construction with hose holders that swivel to the front or back for greater flexibility.

Handles are a quarter turn to full open and close with gradient marks to help in liquid charging. The full 3/8" bore lets you work quickly and efficiently. As always the REVOLVER® is made in the USA.

R-12
R-22
R-502

Includes (4) 60" hoses (unless noted)	Standard 2-1/2" gauges	Glow-in-the-dark 3-1/8" gauges
NO HOSE SET	26000	26025
CCLC KOBRA® HOSE SET	26008	26033
CCLBV KOBRA® HOSE W/ BALL VALVE	-----	26040
CCLS KOBRA® HOSE W/ UL R-410A SECURE SEAL	-----	26044

R-22
R-134a
R-404A

Includes (4) 60" hoses (unless noted)	Standard 2-1/2" gauges	Glow-in-the-dark 3-1/8" gauges
NO HOSE SET	26100	26125
CCLC KOBRA® HOSE SET	26108	26133
CCLBV KOBRA® HOSE W/ BALL VALVE	-----	26140
CCLS KOBRA® HOSE W/ UL R-410A SECURE SEAL	-----	26144

R-22
R-404A
R-410A

Includes (4) 60" hoses (unless noted)	Standard 2-1/2" gauges	Glow-in-the-dark 3-1/8" gauges
NO HOSE SET	26200	26225
CCLC KOBRA® HOSE SET	26208	26233
CCLBV KOBRA® HOSE W/ BALL VALVE	-----	26240
CCLV KOBRA® HOSE W/ WHIP END	-----	26244
CCLS KOBRA® HOSE W/ UL R-410A SECURE SEAL	-----	26246

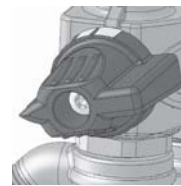
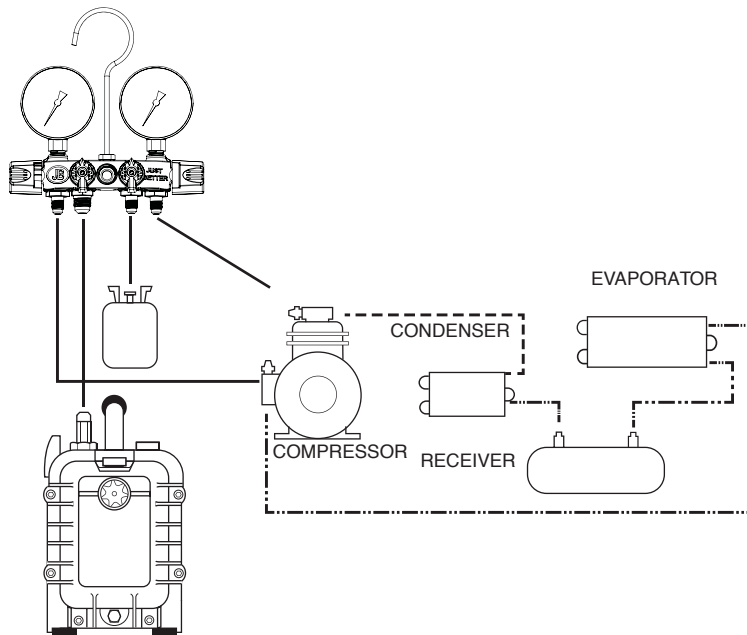

REVOLVER®
Full Open Position

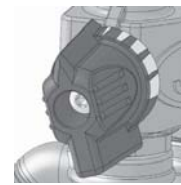

REVOLVER®
Liquid Charging Position
(1st dash)



REVOLVER®
Closed Position

ZEPPELIN

**SURGE DAMPENED GAUGES FOR
REDUCED NEEDLE MOVEMENT**

**FULL 3/8" BORE EVACUATES 40%
FASTER THAN THE COMPETING
4-VALVE MANIFOLD**

**AVAILABLE WITH 2-1/2", 3-1/8", AND
4" SIZE GAUGES**

**REPLACEABLE INTAKE/HOSE HOLDER
FITTINGS FOR STORAGE (ON BACK)**

**SIGHT GLASS STANDARD ON ALL
4-VALVE MODELS**

**COLOR CODED REFRIGERANT DIALS
FOR EASY READING**

PULL-OUT PROOF HANGING HOOK

**PRECISELY MACHINED ANODIZED
ALUMINUM BODY**

**SOFT GRIP RUBBER HAND
WHEELS REDUCE TURNING TO
OPEN/CLOSE**

**HEAVY-DUTY FORGED
ALUMINUM BODY IS RUGGED
AND DURABLE**

ZEPPELIN 4-VALVE ALUMINUM MANIFOLD

**FULL 3/8" BORE
EVACUATES
40% FASTER**

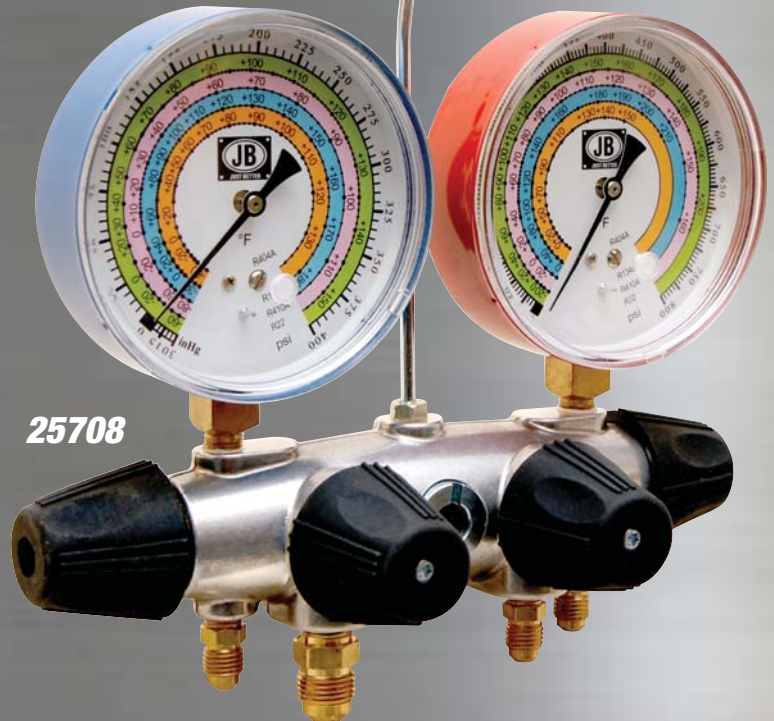

25708



TO FIND THE RIGHT MANIFOLD

- 1. CHOOSE THE DESIRED REFRIGERANT COMBINATION**
- 2. SELECT THE HOSE SET THAT SUITS YOUR NEEDS**
- 3. MOVE ACROSS THE CHART TO FIND THE GAUGES AND YOUR MODEL NUMBER**

METRIC INFORMATION

OFFERED WITH 63.5 MM (2-1/2") METRIC GAUGES READING BAR/PSI, KPA/PSI, AND KG/CM². FOR INFORMATION ON METRIC VERSIONS, PLEASE REFER TO PAGE 32.

4-VALVE ALUMINUM MANIFOLD

The American made 4-valve aluminum ZEPPELIN® series of manifolds features durable molded “soft grip” rubber handles with fingertip grooves that ease opening and closing while the improved stem design means “full open” in only 2½ turns. The aluminum ZEPPELIN® series, available in 2-and 4-valve, also incorporates cutting edge styling and technology to significantly reduce the weight of the manifold.

In addition, JB also offers an increased selection of gauges in metal cases and refrigerant combinations. Standard 2-1/2”, large 3-1/8” glow-in-the-dark, large 3-1/8” liquid-filled gauges, and a four refrigerant 4” gauge (available only on the 4-valve ZEPPELIN®) can be coupled with different refrigerant combinations and JB’s multiple hose options to serve any application. All manifolds include a 60” (152 cm) hose set unless noted otherwise.

	Includes (4) 60” hoses (unless noted)	Standard 2-1/2” gauges	3-1/8” Liquid filled gauges	Glow-in-the-dark 3-1/8” gauges
R-12	NO HOSE SET	25000	25050	25025
R-22	CCLC KOBRA® HOSE SET	25008	25058	25033
R-502	CCLBV KOBRA® HOSE W/ BALL VALVE	-----	25065	25040
	CCLS KOBRA® HOSE W/ UL R-410A SECURE SEAL	-----	25069	25044

	Includes (4) 60” hoses (unless noted)	Standard 2-1/2” gauges	3-1/8” Liquid filled gauges	Glow-in-the-dark 3-1/8” gauges
R-22	NO HOSE SET	25100	25150	25125
R-134A	CCLC KOBRA® HOSE SET	25108	25158	25133
R-404A	CCLBV KOBRA® HOSE W/ BALL VALVE	-----	25165	25140
	CCLS KOBRA® HOSE W/ UL R-410A SECURE SEAL	-----	25169	25144

	Includes (4) 60” hoses (unless noted)	Standard 2-1/2” gauges	3-1/8” Liquid filled gauges	Glow-in-the-dark 3-1/8” gauges
R-22	NO HOSE SET	25200	25250	25225
R-404A	CCLC KOBRA® HOSE SET	25208	25258	25233
R-410A	CCLBV KOBRA® HOSE W/ BALL VALVE	-----	25265	25240
	CCLV KOBRA® HOSE W/ WHIP END	-----	25269	25244
	CCLS KOBRA® HOSE W/ UL R-410A	-----	-----	25246

	Includes (4) 60” hoses (unless noted)	Standard 2-1/2” gauges	3-1/8” Liquid filled gauges	Glow-in-the-dark 3-1/8” gauges
R-427A	NO HOSE SET	-----	25608	25325

	Includes (4) 60” hoses (unless noted)	Standard 2-1/2” gauges	3-1/8” Liquid filled gauges	Glow-in-the-dark 3-1/8” gauges
R-410A	NO HOSE SET	-----	-----	25425

	Includes (4) 60” hoses (unless noted)	Standard 2-1/2” gauges	3-1/8” Liquid filled gauges	Glow-in-the-dark 3-1/8” gauges
R-410A	NO HOSE SET	25500	25550	25525
	CCLC KOBRA® HOSE SET	25508	25558	25533
	CCLV KOBRA® HOSE W/ WHIP END	25523	25573	25548

EXCLUSIVE 4” REFRIGERANT GAUGE WITH 4 REFRIGERANTS. REPLACEMENT GAUGE INFORMATION FOUND ON PAGE 37.

	Includes (4) 60” hoses (unless noted)	4” GAUGES
R-22	CCLC KOBRA® HOSE SET	25708
R-134A	CCLV KOBRA® HOSE W/ WHIP END	25713

GAUGE FEATURES AND REPLACEMENTS ARE DETAILED ON PAGE 33-35. GAUGE BOOTS ARE FEATURED ON PAGE 36. METRIC REPLACEMENT GAUGE VERSIONS ARE DETAILED ON PAGE 36. KOBRA® HOSES ARE DETAILED BEGINNING ON PAGE 38. REFER TO “MANIFOLD REPAIR PARTS” BEGINNING ON PAGE 79 FOR ALL JB MANIFOLD REPAIR PARTS. IF YOU DO NOT SEE A REFRIGERANT COMBINATION, PLEASE CONTACT US AT 800-323-0811.

M4

SURGE DAMPENED GAUGES FOR REDUCED NEEDLE MOVEMENT

ORIGINAL FREE FLOATING DUAL O-RING SEALING SYSTEM FOR FASTER EVACUATION/CHARGING
SEE PAGE 18 FOR DESCRIPTION

AVAILABLE FOR USE WITH R410A

AVAILABLE WITH 2-1/2" AND 3-1/8" SIZE GAUGES WITH AND WITHOUT BOOTS

COLOR CODED REFRIGERANT DIALS FOR EASY READING

ALL METAL GAUGES

PULL-OUT PROOF HANGING HOOK

REPLACEABLE INTAKE/HOSE HOLDER FITTINGS FOR STORAGE

EASY TURNING PLASTIC HAND WHEELS

1/4" BRASS ECONOMY 4-VALVE MANIFOLD



ECONOMY 4-VALVE MANIFOLD

Designed from our industry standard two valve model, the M4 features the same free flowing dual O-ring scaling system. This American made manifold is rugged and durable.

	Includes (4) 60" hoses (unless noted)	Standard 2-1/2" gauges	3-1/8" Liquid filled gauges	Glow-in-the-dark 3-1/8" gauges
R-12				
R-22	NO HOSE SET	M4-8	M4-8B	-----
R-502	CCL 60" STANDARD	M4-5	M4-5B	-----
	CCL 36" STANDARD	M4-36	M4-36B	-----
R-22				
R-134A				
R-404A	Includes (4) 60" hoses (unless noted)	Standard 2-1/2" gauges	3-1/8" Liquid filled gauges	Glow-in-the-dark 3-1/8" gauges
	NO HOSE SET	M4-21125	M4-21125B	M4-22125
	CCL 60" KOBRA® HOSE	M4-21131	M4-21131B	M4-22131
R-22				
R-404A				
R-410A	Includes (4) 60" hoses (unless noted)	Standard 2-1/2" gauges	3-1/8" Liquid filled gauges	Glow-in-the-dark 3-1/8" gauges
	NO HOSE SET	M4-8-410A	M4-8-410AB	M4-22225
	CCL 60" KOBRA® HOSE	M4-5-410A	M4-5-410AB	M4-22231

M2 HEAT PUMP MANIFOLD

HEAT PUMP MANIFOLD



M2-HP-5

TWO CLASS ONE 1% ACCURACY GLOW-IN-THE-DARK METAL GAUGES DESIGNED FOR 800 PSI HEAT PUMP PRESSURES

AVAILABLE WITH AND WITHOUT SET OF KOBRA® HIGH PRESSURE BLACK HOSES

REPLACEABLE INTAKE AND HOSE HOLDER FITTINGS

CLASSIC FORGED BRASS BODY

M2 HEAT PUMP MANIFOLD

Heat pumps use the same refrigeration cycle for heating and cooling. A heat pump can change which coil is the condenser and which is the evaporator by way of a reversing valve. Using a traditional manifold to service a heat pump is not advisable as the low side of the gauge will be damaged when the system goes into heating mode. Therefore, both gauges of the manifold must be designed to handle the high pressures of the heating mode. The JB heat pump manifold has two 3-1/8" glow-in-the-dark Class One 1% accuracy gauges designed with 800 psi to handle the heat pump pressures. Because of the significant temperature glide on R-407C, the pressure/temperature scale has two sections. For temperatures below 50 degrees, the scale is based on saturated vapor (dew point DP). For temperatures above 50 degrees, the scale is based on saturated liquid (bubble point BP). Use the DP for superheat calculations and the BP for subcooling calculations.

R-22

R-410A

R-407C

Includes (3) 60" hoses (unless noted)

NO HOSE SET

CCLC KOBRA® HOSE SET

Class one Glow-in-the-dark 3-1/8" gauges

M2-HP

M2-HP-5

Replacement Gauge

M2-808

METRIC BRASS MANIFOLD

METRIC M2 BRASS MANIFOLD

JB's classic forged brass manifold is offered with 63.5 mm (2-1/2") metric gauges in BAR/PSI, kPA/PSI, and kg/cm² as well as Standard CL and Kobra® CLE series hoses. Look to page 18 for all the features of JB's brass manifold.

Available with 80 mm (3-1/8") metric gauges in select quantities. For more information, please contact sales@jbind.com or 800.323.0811.

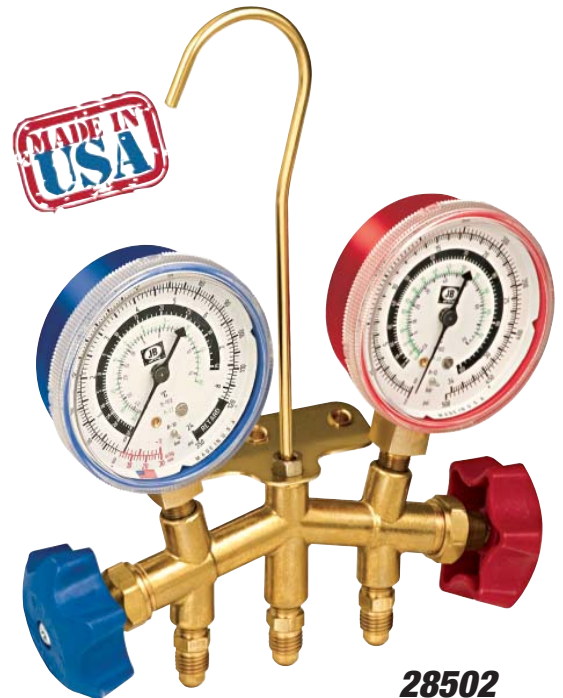

28502

R-134A

Includes (3) 60" hoses (unless noted)	BAR/PSI	kPA/PSI	kg/cm ²
NO HOSE SET	28502	28202	28102
CCLA STANDARD HOSE WITH QUICK COUPLERS	28505	28205	28105

R-12
R-22
R-502

Includes (3) 60" hoses (unless noted)	BAR/PSI	kPA/PSI	kg/cm ²
NO HOSE SET	28572	28272	28172
CCL STANDARD HOSE SET (36"/91 CM HOSE)	28570	28270	28170
CCL STANDARD HOSE SET (60"/152 CM HOSE)	28574	28274	28174
CCLS KOBRA® HOSE WITH UL R-410A SECURE SEAL (60"/152 CM HOSE)	28576	28276	28176

R-134A
R-404A
R-507

Includes (3) 60" hoses (unless noted)	BAR/PSI	kPA/PSI	kg/cm ²
NO HOSE SET	28582	28282	28182
CCL STANDARD HOSE SET (36"/91 CM HOSE)	28580	28280	28180
CCL STANDARD HOSE SET (60"/152 CM HOSE)	28584	28284	28184
CCL KOBRA® HOSE (60"/152 CM HOSE)	28586	28286	28186
CCLS KOBRA® HOSE WITH UL R-410A SECURE SEAL (60"/152 CM HOSE)	28588	28288	28188

R-22
R-404A
R-410A

Includes (3) 60" hoses (unless noted)	BAR/PSI	kPA/PSI	kg/cm ²
NO HOSE SET	28592	28292	28192
CCL KOBRA® HOSE SET	28596	28296	28196
5/16", 1/4", 5/16" CCL KOBRA® HOSE SET	28597	28297	28197
CCLBV KOBRA® HOSE SET WITH BALL VALVE	28599	28299	28199

METRIC ALUMINUM ZEPPELIN® MANIFOLD

METRIC ALUMINUM ZEPPELIN®

JB's ZEPPELIN® manifold is offered with 63.5 mm (2-1/2") metric gauges in BAR/PSI, kPA/PSI, and kg/cm² as well as Standard CL and KOBRA® CLE series hoses. Look to page 22 for all the features of JB's 2-valve aluminum manifold.

Available with 80 mm (3-1/8") metric gauges in select quantities. For more information, please contact sales@jbind.com or 800.323.0811.



28772

R-134A

Includes (3) 60" hoses (unless noted)	BAR/PSI	kPA/PSI	kg/cm ²
NO HOSE SET	28732	28832	28932
CCLA STANDARD HOSE WITH QUICK COUPLERS	28735	28835	28935

R-22
R-404A
R-410A

Includes (3) 60" hoses (unless noted)	BAR/PSI	kPA/PSI	kg/cm ²
NO HOSE SET	28752	28852	28952
CCLC KOBRA® HOSE SET	28754	28854	28954
CCLBV KOBRA® HOSE SET WITH BALL VALVE	28759	28859	28959

R-12
R-22
R-502

Includes (3) 60" hoses (unless noted)	BAR/PSI	kPA/PSI	kg/cm ²
NO HOSE SET	28772	28872	28972
CCL STANDARD HOSE SET (36"/91 CM HOSE)	28770	28870	28970
CCL STANDARD HOSE SET (60"/152 CM HOSE)	28774	28874	28974
CCLS KOBRA® HOSE WITH UL R-410A SECURE SEAL (60"/152 CM HOSE)	28776	28876	28976

R-134A
R-404A
R-507

Includes (3) 60" hoses (unless noted)	BAR/PSI	kPA/PSI	kg/cm ²
NO HOSE SET	28782	28882	28982
CCL STANDARD HOSE SET (36"/91 CM HOSE)	28780	28880	28980
CCL STANDARD HOSE SET (60"/152 CM HOSE)	28784	28884	28984
CCLC KOBRA® HOSE (60"/152 CM HOSE)	28786	28886	28986
CCLS KOBRA® HOSE WITH UL R-410A SECURE SEAL (60"/152 CM HOSE)	28788	28888	28988

4-VALVE METRIC ALUMINUM ZEPPELIN®

4-VALVE METRIC ALUMINUM ZEPPELIN®

Evacuate, charge, or test your system without disconnecting hoses with JB's 4-valve aluminum manifold. This manifold is offered with 63.5 mm (2-1/2") metric gauges and CL and KOBRA® CLE series hoses. See page 26 for all the features of the 4-valve manifold. JB's four valve is a full 3/8" bore which renders it 40% faster than the leading competitor.

Available with 80 mm (3-1/8") metric gauges in select quantities. For more information, please contact sales@jbind.com or 800.323.081.



27782

R-12
R-22
R-502

Includes (4) 60" hoses (unless noted)	BAR/PSI	kPA/PSI	kg/cm2
NO HOSE SET	27772	27872	27972
CCL STANDARD HOSE SET (36"/91 CM HOSE)	27770	27870	27970
CCL STANDARD HOSE SET (60"/152 CM HOSE)	27774	27874	27974
CCLS KOBRA® HOSE WITH UL R-410A SECURE SEAL (60"/152 CM HOSE)	27776	27876	27976

R-22
R-404A
R-410A

Includes (4) 60" hoses (unless noted)	BAR/PSI	kPA/PSI	kg/cm2
NO HOSE SET	27752	27852	27952
CCL KOBRA® HOSE SET	27754	27854	27954
CCLBV KOBRA® HOSE SET WITH BALL VALVE	27759	27859	27959

R-134A
R-404A
R-507

Includes (4) 60" hoses (unless noted)	BAR/PSI	kPA/PSI	kg/cm2
NO HOSE SET	27782	27882	27982
CCL STANDARD HOSE SET (36"/91 CM HOSE)	27780	27880	27980
CCL STANDARD HOSE SET (60"/152 CM HOSE)	27784	27884	27984
CCL KOBRA® HOSE SET (60"/152 CM HOSE)	27786	27886	27986
CCLS KOBRA® HOSE WITH UL R-410A SECURE SEAL (60"/152 CM HOSE)	27788	27888	27988

2-1/2" STANDARD METAL GAUGES

2-1/2" (63.5mm) METAL GAUGES

These high quality, all steel case standard gauges are identical to the gauges used on our manifold sets. They are surge damped for accuracy. Gauges are sensitive instruments and therefore should not be subjected to pressures beyond scale.

- High impact clear view Lexan lens
- Recalibration screw
- Full size brass movements
- 1/8" MPT connections

REFRIGERANTS	COMPOUND STEEL CASE	PRESSURE STEEL CASE
R-12, R-22, R-502**	M2-250	M2-500
R-22, R-404A, R-410A**	M2-460	M2-465
R-134A, R-404A, R-507	M2-420	M2-425
R-134A	M2-350	M2-355
R-410A	M2-410	M2-415



R-134A, R-404A and R-507 Refrigerant Gauges

Compound Gauge: 30" vacuum to 120 psi, retard to 350 psi. Pressure Gauge: 0 to 500 psi.

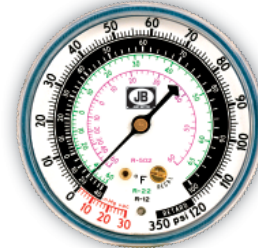

R-12, R-22 and R-502 Refrigerant Gauges

Compound Gauge: 30" vacuum to 120 psi, retard to 350 psi. Pressure Gauge: 0 to 500 psi.

Available with Brass or Chrome Cases
Compound M2-250B or M2-250C and Pressure M2-500B.



R-134a Refrigerant Gauges

Compound Gauge: 30" vacuum to 120 psi, retard to 350 psi. Pressure Gauge: 0 to 500 psi.



R-410A Refrigerant Gauges

Compound Gauge: 30" vacuum to 250 psi, retard to 500 psi. Pressure Gauge: 0 to 800 psi.



R-22, R-404A, R-410A Refrigerant Gauges

Compound Gauge: 30" vacuum to 250 psi, retard to 500 psi. Pressure Gauge: 0 to 800 psi.
Available with Brass or Chrome Cases.

3-1/8" GAUGES

ILLUMINATED GAUGES

JB offers 3-1/8" (80 mm) illuminated gauges. The glow-in-the-dark dials store energy to emit light in dimly lit or dark applications. The R-410A only gauges are not glow-in-the-dark due to their pink dial. The illuminated large gauges are also available with 1% accuracy rating. Please refer to the 1% accuracy area on the manifold charts for refrigerant combination availability.

REFRIGERANTS	COMPOUND STEEL CASE ILLUMINATED	PRESSURE STEEL CASE ILLUMINATED
R-12, R-22, R-502	M2-800	M2-805
R-22, R-134A, R-404A	M2-851	M2-856
R-22, R-404A, R-410A	M2-820	M2-825
R-410A	M2-810	M2-815
R-22, R-410A, R-407C	M2-830	M2-831
R427A, R422B, R407A	M2-828	M2-829
R-22, R-404A, R-410A	M2-924	M2-925
R-22, R-134A, R-404A	M2-951	M2-956



M2-810 and M2-815
(Note: These gauges do not illuminate)

R-410A Refrigerant Gauges

Compound Gauge: 30" vacuum to 250 psi, retard to 500 psi. Pressure Gauge: 0 to 800 psi.



R427A, R422B and R407A Refrigerant Gauges

Compound Gauge: 30" vacuum to 250 psi, retard to 500 psi. Pressure Gauge: 0 to 800 psi.



M2-851 and M2-856

R-22, R-134A and R-404A Refrigerant Gauges

Compound Gauge: 30" vacuum to 120 psi, retard to 350 psi. Pressure Gauge: 0 to 500 psi. Also available in Class One 1% certified accuracy gauges. M2-951 Compound and M2-956 Pressure.



M2-820 and M2-825

R-22, R-404A, R-410A Refrigerant Gauges

Compound Gauge: 30" vacuum to 250 psi, retard to 500 psi. Pressure Gauge: 0 to 800 psi. Also available in Class One 1% certified accuracy gauges. M2-924 Compound and M2-925 Pressure.



R-22, R-410A and R-407C Refrigerant Gauges

Compound Gauge: 30" vacuum to 250 psi, retard to 500 psi. Pressure Gauge: 0 to 800 psi.

NOT PICTURED

R-12, R-22 and R-502 Refrigerant Gauges

Compound Gauge: 30" vacuum to 120 psi, retard to 350 psi. Pressure Gauge: 0 to 500 psi.

3-1/8" LIQUID-FILLED GAUGES

3-1/8" (80 MM) LIQUID-FILLED GAUGES

Made with European craftsmanship and quality standards, these Class 1 gauges are +/- 1% accuracy. These liquid-filled gauges are offered with an exclusive four refrigerant combination dial for most applications.

- Class 1 gauges for 1% accuracy
- Recalibration screw
- Heavy-duty case withstands daily use
- No leak system prevents glycerin loss

REFRIGERANTS	COMPOUND LIQUID-FILLED	PRESSURE LIQUID-FILLED
R-22, R-134A, R-404A, R-410A	M2-860	M2-865

JB EXCLUSIVE

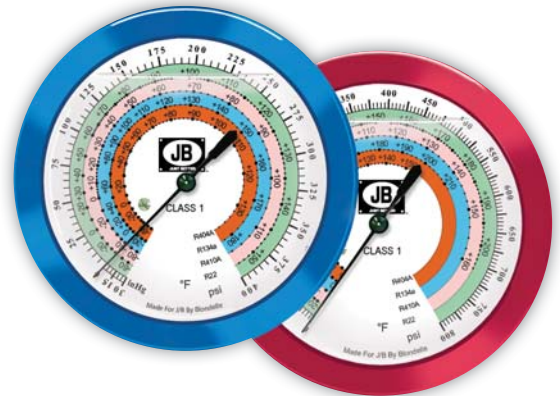

**FOUR REFRIGERANT
COMBINATION DIAL FOR MOST
APPLICATIONS**

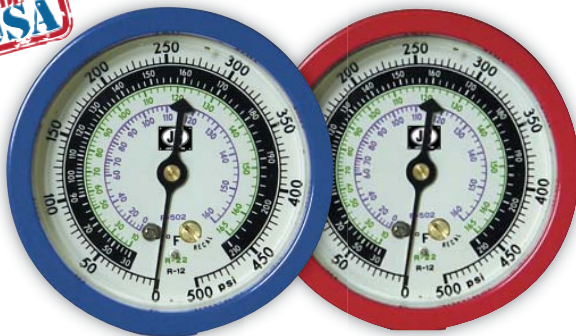

HIGHLY ACCURATE TO 1%

1/8" MPT FITTING

**TOUGH, IMPACT-RESISTANT ZYTEL CASING WITH
OVER 10,000 POUND TENSILE STRENGTH**

**TEMPERATURE COMPENSATED FOR CHANGES IN
CASE PRESSURE FOR ACCURACY**

3-1/8" (80 MM) LIQUID-FILLED GAUGES

These 3-1/8" (80 mm) American made liquid-filled gauges are simply the toughest in the industry and are backed by an extended warranty. Features an internal "breathing diaphragm" that eliminates air bubbles which can distort the reading. Thus, calibration is unnecessary. The seal on the internal diaphragm prevents freezing and corrosion.

REFRIGERANTS	COMPOUND LIQUID-FILLED	PRESSURE LIQUID-FILLED
R-12, R-22, R-502	M2-870	M2-875
R-22, R-134A, R-404A	M2-880	M2-885
R-22, R-404A, R-410A	M2-890	M2-895

NEW! CLASS ONE 4 INCH GAUGES WITH 4 REFRIGERANTS

These 4" gauges feature 1% accuracy and illuminate in low and dimly lit areas. Features the four most common refrigerants in use today. Available on the ZEPPELIN® four valve manifold (see page 27). Please note, gauges may not fit on all manufacturer's manifold bodies due to the width of these gauges.



REFRIGERANTS	COMPOUND LIQUID-FILLED	PRESSURE LIQUID-FILLED
R-22, R-134A, R-404A, R-410A	M2-400	M2-405

MANIFOLD ACCESSORIES

63.5mm (2-1/2") METRIC GAUGES

These high quality metric gauges are identical to the gauges used on our manifold sets. Featuring high impact Lexan lenses for better durability and visibility. Gauges are sensitive instruments and therefore should not be subjected to pressures beyond scale. Please refer to pages 32-34 for product information on metric manifolds.

- Available in bar/psi, kpa/psi, and kg/cm² measurements
- Full size brass movements
- Recalibration screw
- 1/8" Mpt connection

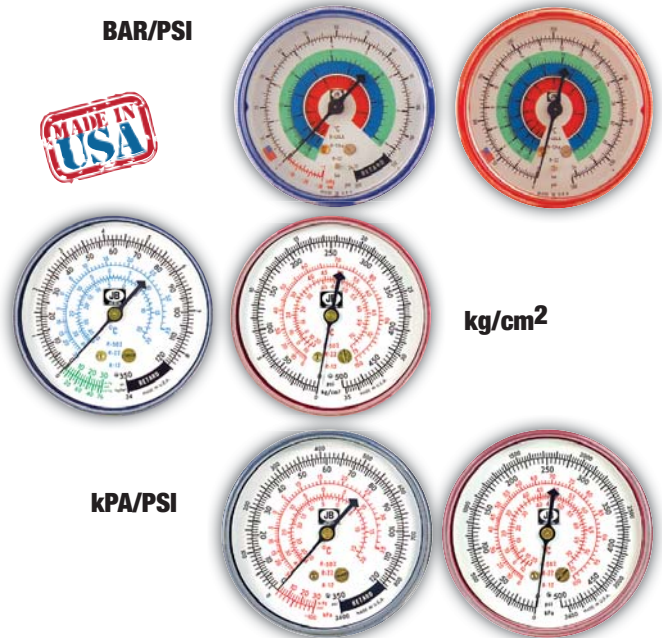

REFRIGERANT COMBINATION	COMPOUND BAR/PSI	PRESSURE BAR/PSI	COMPOUND KPA/PSI	PRESSURE KPA/PSI	COMPOUND KG/CM2	PRESSURE KG/2
R-12, R-22, R-502	29280	29285	29260	29263	29384	29385
R-22, R-404, R-410A	29310	29315	29311	29316	29312	29317
R-134A, R-404A, R-410A	29290	29295	-----	-----	29292	29297
R-134A	29330	29335	29331	29336	29332	29337
R-22, R-134A, R-404A	29333	29338	-----	-----	-----	-----

FOR SAFETY REASONS, GAUGES AND HOSES NOT SPECIFIED FOR R410 CAN DAMAGE PRODUCT AND CAUSE INJURY.

PROTECTIVE BOOTS

Protective gauge boots add even more durability to both 2-1/2" (63.5 mm) and 3-1/8" (80 mm) gauges on your manifold. They are not required on liquid-filled gauges.

PART NO.	DESCRIPTION
MR-590	2-1/2" Black JB boots
MR-597	Set of red and blue 2-1/2" boots
MR-594	3-1/8" Red four refrigerant liquid gauge boot
MR-595	3-1/8" Blue four refrigerant liquid gauge boot
MR-593	3-1/8" Black boot
MR-596	Set of two 3-1/8" black boots



MANIFOLD ACCESSORIES

CONTROLS PUMP 40200

The controls pump is used in conjunction with a gauge manifold to quickly and accurately test and set single or dual pressure controls to 300 psi and 25" of vacuum.



PART NO.	DESCRIPTION
40200	Controls pump with 40201
40201	Replacement adapter with O-ring
40202	Replacement adapter O-ring
40203	Replacement pressure access valve with 35 psi core
40204	Replacement piston O-ring
40205	Replace pressure valve core 35 psi
40206	Replace vacuum valve core 3 psi
40207	Replacement vacuum access valve with 35 psi core

LIQUID CHARGING ADAPTERS

Metering element reduces liquid flow to a level below capacity of compressor. This assures a safe, fast charge without damaging the compressor. Accepts liquid refrigerant from the cylinder and discharges into low side of the system. Liquid charging is recommended when charging blends into refrigeration and air conditioning systems, and a liquid charger adapter is necessary for safe and fast liquid charging through the low side of a system. Eliminates the time and effort of heating cylinders.



PART NO.	DESCRIPTION
LC-4	1/4" Liquid charging adapter
LC-5	5/16" Liquid charging adapter

MANIFOLD REBUILD KITS

Rebuild kits are available for our manifold series. Standard rebuild kits include a stem, nut, piston with seat, and O-rings. Premium rebuild kits feature 2 standard kits plus 2 handwheels and screws. For a complete list of manifold repair parts, please refer to the manifold repair parts section beginning on page 79.

PART NO.	DESCRIPTION
M2R-S	Standard M2 rebuild (also fits M5 thru M9 series)
M2R-P	Premium M2 rebuild (fits M2 series only)
M4R-S	Standard M4 rebuild
M4R-P	Premium M4 rebuild
2VZR-S	Standard ZEPPELIN® 2-valve rebuild (fits both Aluminum and brass)
2VZR-P	Premium ZEPPELIN® 2-valve rebuild (fits both aluminum and brass)
4VZR-S	Standard ZEPPELIN® 4-valve rebuild
4VZR-P	Premium ZEPPELIN® 4-valve rebuild

FOR SAFETY REASONS, GAUGES AND HOSES NOT SPECIFIED. FOR R-410A CAN DAMAGE PRODUCT AND CAUSE INJURY. FOR MANIFOLD REPLACEMENT PARTS, PLEASE REFER TO "MANIFOLD REPAIR PARTS" BEGINNING ON PAGE 79.

REPLACEMENT LENS

PART NO.	DESCRIPTION
MR-517	2-1/2" (63.5 mm) screw-on lens (one) fits plastic and metal
MR-533	80 mm snap-on lens (one)

GAUGE MOUNTING BRACKETS

PART NO.	DESCRIPTION
M2-106	1/8" FPT
M2-108	1/4" FPT

KOBRA® HIGH PRESSURE HOSE



ANATOMY OF THE KOBRA® CHARGING HOSE

NITRILE COVER

KEVLAR BRAID

RUBBER

VENEER TUBE

Provides a 5 to 1
safety factor - beats
industry standard
of 4-1



KOBRA® HOSES SOLD IN SETS COME IN A UV PROTECTIVE BAG TO RESIST FADING.

MAXIMUM FLOW. NO BLOWOUTS. BEST HOSE IN THE INDUSTRY.

JB has made two revolutionary patent pending design improvements to our American made KOBRA® Series of high pressure hoses. The first change is incorporated into our CCLE environmental KOBRA® Hose which features internal enhancements that significantly reduce blowouts, provide maximum flow, and are the best hoses available on the market. We have redesigned the gasket, the barb, the depressor, and the cup as a complete upgrade to the existing hose fitting.

The second change is incorporated into our CCLS secure seal KOBRA® hose which features a new low loss fitting that is the industry's only UL recognized fitting approved for R-410A. The secure seal fitting traps refrigerant inside the hose to help meet non-venting requirements. The low loss fitting is also completely repairable.

In addition, all of JB's KOBRA® series of refrigerant hoses are made from Kevlar®—the same material that stops bullets in bullet-proof vests. The hoses are incredibly strong and flexible. A common crimp grips the full circumference of the hose, yielding a maximum hold and uniform seal that prevents leaks and busts. KOBRA® hoses feature a nitrile cover which is better than neoprene because it is more resistant to oil, giving the hoses a longer life. With a pressure rating of 800 psi working and 4000 psi burst, these hoses can be used with ALL common refrigerants except ammonia. JB hoses are repairable, please see replacement parts listed with each series.

KOBRA® HIGH PRESSURE HOSE

SECURE SEAL UL APPROVED FOR R-410A

JB is proud to announce that our secure seal hose is now UL recognized for use with R-410A. The ONLY hose in the industry that is UL recognized for R-410A. Our CCLS series of KOBRA® hoses open to full flow and have a low loss fitting that traps the refrigerant inside the hose to help meet non-venting requirements. The internal thrust washer ensures free rotation. The secure seal fitting itself is rebuildable with parts kit. The low loss fitting is offered on our KOBRA® high pressure hose with 800 PSI working pressure and 4000 PSI burst. As with all JB hoses, the CCLS KOBRA® hose is manufactured, assembled, and tested in the USA.



KOBRA® CLS SERIES WITH UL RECOGNIZED LOW LOSS FITTING

- UL approved for R-410a
- Rebuildable
- Opens to full flow
- Stainless steel thrust washer insures free rotation even under high pressure
- Improved flow
- Three point contact on depressor
- Low loss fitting adapters available on page 52

**800 Working
4000 Burst**

LENGTH	BLUE	YELLOW	RED	BYR SET	4 PACK
36" (91 cm)	CLS-36B	CLS-36Y	CLS-36R	CCLS-36	CCLS4-36
48" (122 cm)	CLS-48B	CLS-48Y	CLS-48R	CCLS-48	CCLS4-48
60" (152 cm)	CLS-60B	CLS-60Y	CLS-60R	CCLS-60	CCLS4-60
72" (182 cm)	CLS-72B	CLS-72Y	CLS-72R	CCLS-72	CCLS4-72
10' (3 m)	CLS-120B	CLS-120Y	CLS-120R	-----	-----
25' (7.6 m)	CLS-300B	CLS-300Y	CLS-300R	-----	-----
50' (15.2 m)	CLS-600B	CLS-600Y	CLS-600R	-----	-----
75' (22.8 m)	CLS-900B	CLS-900Y	CLS-900R	-----	-----
100' (30.5 m)	CLS-1200B	CLS-1200Y	CLS-1200R	-----	-----

USE REBUILD KIT 33112RK

P90022 REPLACEMENT O-RING

NEW FOUR PACK INCLUDES 3/8" KOBRA® BLACK HOSE



KOBRA® CLS SERIES LARGE NUT (NOT UL APPROVED)

Not UL approved for R-410A.

Tighter internally making repair more difficult than our other version.

Please note, when the depressor is down, this fitting is more restrictive in flow.

LENGTH	BLUE	YELLOW	RED	BYR SET
36" (91 cm)	CLSB-36B	CLSB-36Y	CLSB-36R	CCLSB-36
48" (122 cm)	CLSB-48B	CLSB-48Y	CLSB-48R	CCLSB-48
60" (152 cm)	CLSB-60B	CLSB-60Y	CLSB-60R	CCLSB-60
72" (182 cm)	CLSB-72B	CLSB-72Y	CLSB-72R	CCLSB-72

USE REBUILD KIT 33112RKB

P90024 REPLACEMENT O-RING

KOBRA® HIGH PRESSURE HOSE

KOBRA® CLE SERIES WITH GASKET SEAL FITTING

Our KOBRA® CLE series features a blowout resistant gasket. Our patent pending design of the fittings features a hood that locks the gasket into the fitting with a straight edge to straight edge force that eliminates the blowout of the gasket. The barbed depressor locks into the gasket exerting more outward force pushing the gasket further into place. The depressor is precisely machined and has a dimple that guides the valve core into place. The depressor is designed to provide maximum flow. Maximum flow, no blowouts, the JB difference.

CLE KOBRA® CUT AWAY

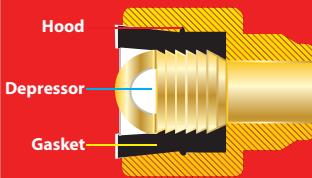

Gasket features a hood with a straight edge that snaps into straight edge of barb. This straight edge to straight edge force eliminates blow outs.

Depressor is barbed, locking into gasket. Outward force of depressor pushes gasket further into place resulting in no blow outs.

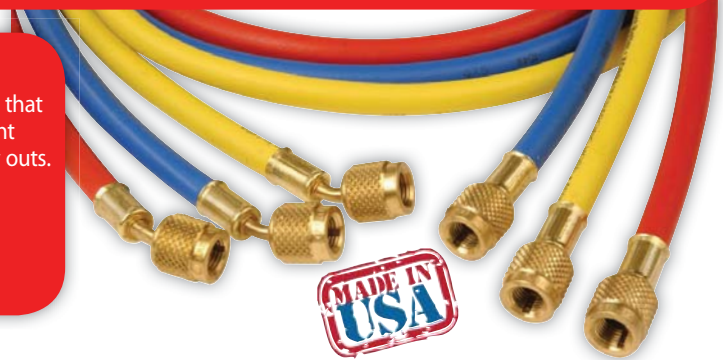

NEW FOUR PACK INCLUDES 3/8" KOBRA® BLACK HOSE

LENGTH	BLUE	YELLOW	RED	BYR SET	BLACK	4 PACK
36" (91 cm)	CLE-36B	CLE-36Y	CLE-36R	CCLC-36	CLB-36	CCLE4-36
48" (122 cm)	CLE-48B	CLE-48Y	CLE-48R	CCLC-48	CLB-48	CCLE4-48
60" (152 cm)	CLE-60B	CLE-60Y	CLE-60R	CCLC-60	CLB-60	CCLE4-60
72" (182 cm)	CLE-72B	CLE-72Y	CLE-72R	CCLC-72	CLB-72	CCLE4-72
10' (3 m)	CLE-120B	CLE-120Y	CLE-120R	-----	-----	-----
25' (7.6 m)	CLE-300B	CLE-300Y	CLE-300R	-----	-----	-----
50' (15.2 m)	CLE-600B	CLE-600Y	CLE-600R	-----	-----	-----
75' (22.8 m)	CLE-900B	CLE-900Y	CLE-900R	-----	-----	-----
100' (30.5 m)	CLE-1200B	CLE-1200Y	CLE-1200R	-----	-----	-----

USE REBUILD KIT 90514

P511 REPLACEMENT GASKET

P90514 REPLACEMENT DEPRESSOR

KOBRA® CLBV SERIES WITH GASKET SEAL FITTING

Our KOBRA® CLBV series features 1/4 turn lever style ball valves at one end to trap refrigerant in hose. Helps meet non-venting requirements.

**800 Working
psi**

**4000 Burst
psi**

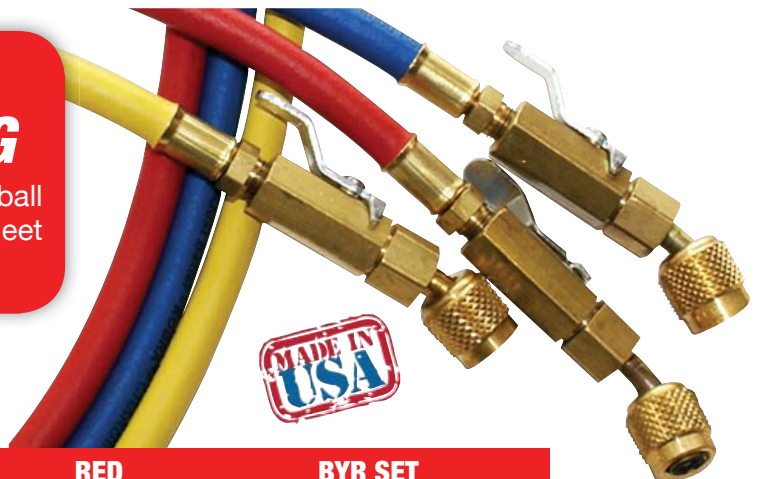

LENGTH	BLUE	YELLOW	RED	BYR SET
36" (91 cm)	CLBV-36B	CLBV-36Y	CLBV-36R	CCLBV-36
48" (122 cm)	CLBV-48B	CLBV-48Y	CLBV-48R	CCLBV-48
60" (152 cm)	CLBV-60B	CLBV-60Y	CLBV-60R	CCLBV-60
72" (182 cm)	CLBV-72B	CLBV-72Y	CLBV-72R	CCLBV-72

USE REBUILD KIT 90514

P511 REPLACEMENT GASKET

P90514 REPLACEMENT DEPRESSOR

KOBRA® HIGH PRESSURE HOSE

KOBRA® CLV SERIES WITH BALL VALVE WHIP ENDS

Our KOBRA® CLV series features 1/4 turn lever style ball valves on 6" whip ends to trap refrigerant in hose. Helps meet non-venting requirements. To replace the whip end without the ball valve, order CLP series. To include the ball valve, order the CLV-6 series. The CLV-6 also retrofit CLE series to create a non-venting set of hoses.



WHIP END ONLY MPT FITTING



REPLACEMENT FOR CLV HOSE

LENGTH	BLUE	YELLOW	RED	BYR SET
36" (91 cm)	CLV-36B	CLV-36Y	CLV-36R	CCLV-36
48" (122 cm)	CLV-48B	CLV-48Y	CLV-48R	CCLV-48
60" (152 cm)	CLV-60B	CLV-60Y	CLV-60R	CCLV-60
72" (182 cm)	CLV-72B	CLV-72Y	CLV-72R	CCLV-72

LENGTH	BLUE	YELLOW	RED
6" (15 cm)	CLP-6B	CLP-6Y	CLP-6R

USE REBUILD KIT 90514 P511 REPLACEMENT GASKET
P90514 REPLACEMENT DEPRESSOR

WHIP END ONLY WITH BALL VALVE



CONNECTS TO HOSE FITTING

LENGTH	BLUE	YELLOW	RED	BYR SET	BLACK
1/4" X 6" (15 cm)	CLV-6B	CLV-6Y	CLV-6R	CCLV-6	CLV-6BL
3/8" X 6" (15 cm)	-----	CLV6-6Y	-----	-----	CLV6-6BL

3/8" KOBRA® BLACK AND YELLOW CHARGING HOSE

Available in yellow and black, these hoses feature gasket seal fittings. Both colors of charging hose have a 600 psi working pressure and 3000 psi burst. Lined with Kevlar®, these hoses are tough and dependable. Black hoses are available with and without UL approved shut-off ball valve.



LENGTH	BLACK WITH BALL VALVE SHUT-OFF	BLACK WITH-OUT VALVE	YELLOW
36" (91 cm)	CLV6-36	CL6-36	CL6-36Y
48" (122 cm)	CLV6-48	CL6-48	CL6-48Y
60" (152 cm)	CLV6-60	CL6-60	CL6-60Y
72" (182 cm)	CLV6-72	CL6-72	CL6-72Y

KOBRA® HIGH PRESSURE HOSE

1/4" , 3/8" AND 1/2" HEAVY-DUTY BLACK CHARGING HOSE

New heavy-duty charging hose reduces permeation and handle 900 psi working, 3500 psi burst. Available in black only. Straight fittings by straight fittings.

LENGTH	1/4"	3/8"	1/2"
36" (91 cm)	CL4HD-36	CL6HD-36	CL2HD-36
48" (122 cm)	CL4HD-48	CL6HD-48	CL2HD-48
60" (152 cm)	CL4HD-60	CL6HD-60	CL2HD-60
72" (182 cm)	CL4HD-72	CL6HD-72	CL2HD-72

MADE IN USA
900 WORKING
3500 BURST



3/8" AND 1/2" EVACUATION HOSE

New heavy-duty evacuation hose features no valve core depressors for faster evacuation and deeper vacuums. The fittings are different on each end and handle 900 psi working, 3500 psi burst. Available in black only. Straight fittings by straight fittings.

EVACUATION HOSE

LENGTH	1/4" x 1/2"	1/4" x 3/8"
60" (152 cm)	CL84-60	CL64-60

DEEP VACUUM FLEXIBLE METAL HOSES

Unlike charging hose, our flexible metal lines will not permeate under vacuum. Our metal lines feature finger-tight O-ring coupler ends.

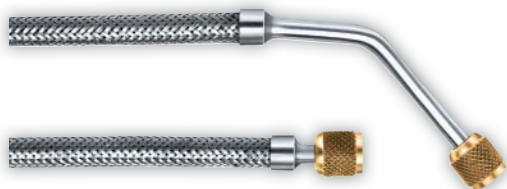

MADE IN USA

DIRECTION OF PERMEATION THROUGH HOSE WALL

Even with the advanced technology of today's hoses, permeation through the hose compound still exists.

When checking pressure rise, the atmosphere will permeate to the lower pressure in the hoses and the micron reading will slowly rise.

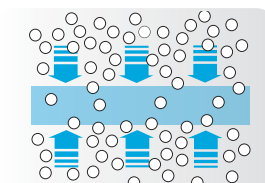
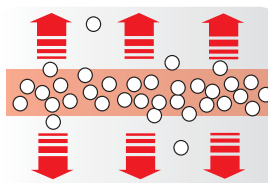

CHARGING SYSTEM

Gas under pressure in the hose will permeate to the lower pressure of the atmosphere.

EVACUATION

The atmosphere which has a higher pressure permeates to the lower pressure in the hose.

PART NO.	DESCRIPTION
D10436	1/4" x 36" flexible metal line (one 45° fitting)
D10472	1/4" x 72" flexible metal line (one 45° fitting)
D10636	3/8" x 36" flexible metal line (one 45° fitting)
D10660	3/8" x 60" flexible metal line (one 45° fitting)
DV-294	1/4" x 10" flexible metal line (straight fittings)
P90009	1/4" replacement O-ring (10 pack)
P90012	3/8" replacement O-ring (10 pack)

1/4" STANDARD CHARGING HOSE

With a pressure rating of 750 psi working and 3000 psi burst, these hoses are ideal or use with all standard refrigerants (except high pressure refrigerants). Permeation can be detected and will vary with refrigerant type and time of exposure.

LENGTH	BLUE	YELLOW	RED	BYR SET
36" (91 cm)	CL-36B	CL-36Y	CL-36R	CCL-36
48" (122 cm)	CL-48B	CL-48Y	CL-48R	CCL-48
60" (152 cm)	CL-60B	CL-60Y	CL-60R	CCL-60
72" (182 cm)	CL-72B	CL-72Y	CL-72R	CCL-72

MADE IN USA

700 WORKING
3000 BURST

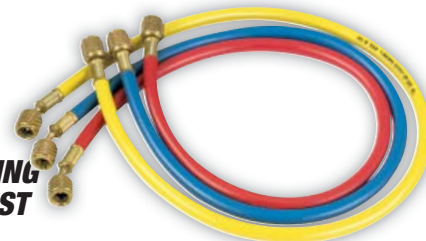

ACCESS VALVES

JB INDUSTRIES ACCESS VALVES

JB machines access valves at our Aurora, Illinois facility using brass of the highest content: 65% copper and 35% zinc. This gives our brass fittings and access valves high tensile strength while resisting corrosion. If you are not buying American made brass fittings, ask yourself, what is the metal content used in the imported versions, do you trust it, and can you afford to have them fail? We also machine all of our valves according to the strict specifications of ARI to ensure proper sealing of valve and core surfaces. Quality and dependability from American made products.

AC/R COPPER TUBE FITTING GUIDE

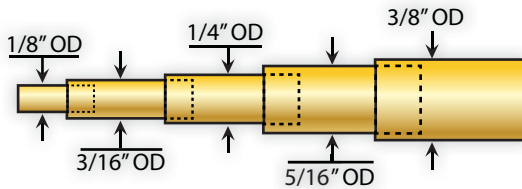

CONNECTING TUBE SIZE

TUBE SIZE	ODS INTERNAL TUBE FIT	ODF EXTERNAL TUBE FIT	ODF SWAGE FIT
1/8"	-----	3/16"	-----
3/16"	1/8"	1/4"	3/16"
1/4"	3/16"	5/16"	1/4"
5/16"	1/4"	3/8"	5/16"
3/8"	5/16"	-----	3/8"

ODS AND ODF FIT DESCRIPTIONS

Descriptions for solder/braze access valves specify the connecting tube OD. Size and type fit illustrated below are the types of fit for A31723 valve.

Connecting line slips around access fitting. Look under the ODF heading in the AC/R Copper Tube chart above.

There are two types. JB access valve description for ODF is always "swage fit." The connecting tube OD is the same OD as the fitting end. Therefore, A31723 above will also slip into 5/16" OD tube.

If connecting to wrought copper fitting, use ODF swage size.

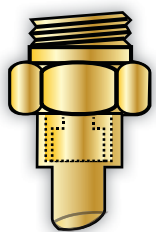

Swage
1/4" OD Tube

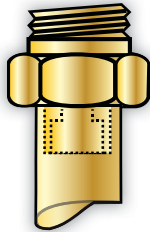

5/16" Tube

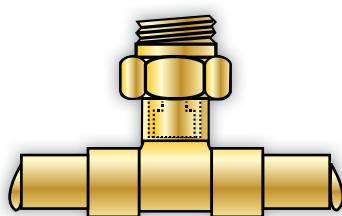

Wrot Copper Fitting
1/4" x 1/4" x 1/4" Tee

PART NO.

A31723

TYPE OF FIT

3/16" ODS X 1/4" ODF

3/16" OD FIT

Connecting line slips into solder cup. Note extra depth solder cups on copper solder tees.

Internal Solder Cup

3/16" OD Tube

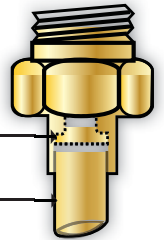

NOMENCLATURE:

FOR EASY REFERENCE, THE LAST TWO NUMERALS OF OUR FLARE FITTINGS CORRESPOND TO THEIR RESPECTIVE TUBE SIZES.

NUM.	TUBE SZ.	NUM.	TUBE SZ.
02	1/8"	08	1/2"
03	3/16"	10	5/8"
04	1/4"	12	3/4"
05	5/16"	14	7/8"
06	3/8"	18	1-1/8"

ACCESS VALVES

SPECIFICATIONS

ARI STANDARD	720-2002
ARI TORQUE	3.0 - 5.0 inches/pound
TEMP RANGE	-40 F° to 250 F° (-40 C° to 121 C°)
VALVE BODIES	Brass
VALVE CORE	Stainless steel and brass for use with all refrigerants such as R-12, R-22, R-134a, R-410A, and R-502. Resistant to oils, alkalites, and diluted mineral acids.

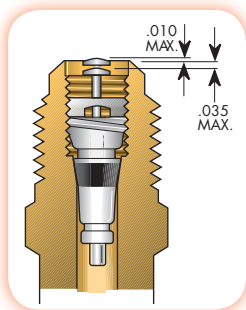

VALVE CORE PIN LOCATION

After valve installation, replace valve core with valve core tool. Torque to ARI specifications.

GENEROUS COUNTER BORE ALLOWS REMOVAL OF CORE IF FLARE BECOMES DAMAGED.

ALL PIPE CONNECTIONS HAVE INTERNAL BRAZE CUPS FOR DIP TUBE APPLICATIONS.

ALL TEES AND CROSSES ARE TAPPED TO RECEIVE AN ACCESS CORE IN ALL 1/4" SAE FLARE ENDS.

ALL VALVES ARE EQUIPPED WITH CAP AND ONE VALVE CORE (BRAZE TYPE LOOSELY ASSEMBLED).

MULTI-STEP

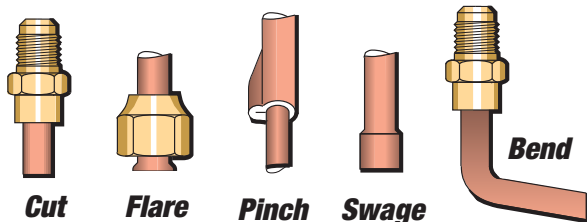

PART NO.	TUBE EXT. SIZE	BLISTER PKG.
A31009	1/8" OD EXT; 3/16", 1/4" and 5/16" ODF body steps	3
A31011	3/16" OD EXT; 1/4" and 3/8" ODF body steps	3

COPPER TUBE EXTENSION

Use these fittings with Sil-phos alloy and copper fittings. Install through the side of the larger line to extend length approximately two inches. Includes cap (NFT5-4) and valve core. 1/4" ID.

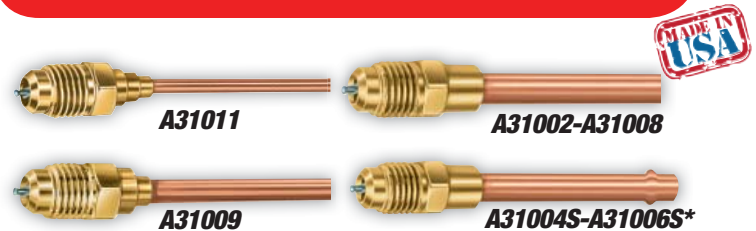

PART NO.	TUBE EXT. SIZE	BLISTER PKG.
A31002	1/8" OD	5
A31003	3/16" OD X 1/8" ID	5
A31004	1/4" OD X 3/16" ID	5
A31005	5/16" OD X 1/4" ID	5
A31006	3/8" OD X 5/16" ID	5
A31008	1/2" OD	3
A31004S	1/4" OD	5
A31006S	3/8" OD	5

NOTE: OD X ID sizes are for copper tube extension. For connecting line size, see chart on left for ODS and ODF fit.

COPPER SADDLE BRAZE/TAPPER

The new A32800 series of saddles offer the best protection from leaks. Once brazed on, you can check for leaks before piercing the tube. The steel pin is inserted and the cap is tightened down to pierce the tube. Body sizes are contoured to match specific tube sizes. The Braze/Tapper has a hardened steel-piercing needle and is furnished with a cap.



PART NO.	TUBE SIZE	BLISTER PKG.	PART NO.	TUBE SIZE	BLISTER PKG.
*A32804	1/4"	5	*A32904	1/4"	5
*A32805	5/16"	5	*A32905	5/16"	5
*A32806	3/8"	5	*A32906	3/8"	5
*A32808	1/2"	3	*A32908	1/2"	3
*A32810	5/8"	3	*A32910	5/8"	3
*A32812	3/4"	2	*A32912	3/4"	2
*A32814	7/8"	2	*A32914	7/8"	2
*A32818	1-1/8"	2			

*Core pre-torqued to ARI specifications torque flare nut to 8 to 10 ft. lbs.

ACCESS VALVES

COPPER BRAZE TEES

- BEND, CUT, FLARE, SWAGE OR PINCH
- EXTRA DEPTH SLIP FIT BRAZE CUPS
- SIMPLE INSTALLATION ANYWHERE ALONG LINE
- USE SIL-PHOS ALLOY

SEE PAGE 43 FOR FORGED BRASS TEES

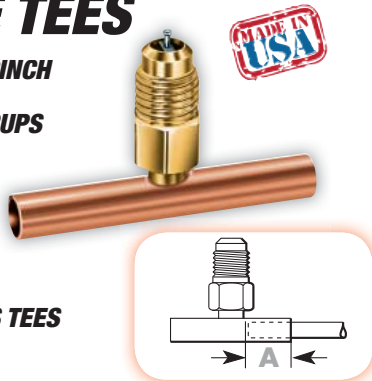

SWAGED COPPER BRAZE TEES

- SIMPLE INSTALLATION ANYWHERE ALONG LINE
- BRAZE CUP ENDS
- USE SIL-PHOS ALLOY

SEE PAGE 43 FOR FORGED BRASS TEES



PART NO.	SLIP FIT CONNECT LINE SIZE	OAL	LENGTH "A"	BLISTER PKG.
A31134	1/4" ODS X 5/16" ODF	2-1/8"	1"	3
A31135	5/16" ODS X 3/8" ODF	2-1/8"	1"	3
A31136	3/8" ODS X 1/2" ODF	2-1/8"	1"	3
A31138	1/2" ODS	2-1/8"	1"	3
A31140	5/8" ODS	2-1/2"	1"	1
A31142	3/4" ODS	3"	1-1/4"	1
A31144	7/8" ODS	3-1/2"	1-1/2"	1
A31148	1-1/8" ODS	3-13/16"	1-5/8"	1
A31154	3/16" ODS X 1/4" ODF	4"	1-15/16"	2
A31155	1/4" ODS X 5/16" ODF	4"	1-15/16"	2
A31156	5/16" ODS X 3/8" ODF	4"	1-15/16"	2

PART NO.	SLIP FIT CONNECT LINE SIZE	OAL	BLISTER PKG.
A31334	1/4" OD	2- 1/8"	3
A31335	5/16" OD	2 -1/8"	3
A31336	3/8" OD	2- 1/8"	3
A31338	1/2" OD	2- 1/8"	3
A31340	5/8" OD	2 -1/2"	1
A31342	3/4" OD	3"	1
A31344	7/8" OD	3- 1/2"	1
A31348	1-1/8" OD	3 -13/16"	1

MULTI-STEP

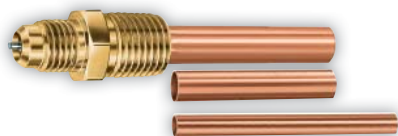

PART NO.	TUBE EXT. SIZE	BLISTER PKG.
A31012	1/8" ext. 1/8" and 3/16" tube	3

COPPER 90° ELBOW



PART NO.	CONNECTING LINE SIZE	PKG.
A31160	5/8" ODS	1
A31162	3/4" ODS	1
A31164	7/8" ODS	1
A31168	1-1/8" ODS	1

COPPER ACCESS UNION

- INSTALL VALVE IN ANY POSITION
- USE SIL-PHOS ALLOY
- CONNECTING LINE SIZE FOR ODS AND ODF EXTERNAL TUBE ENDS

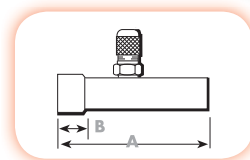
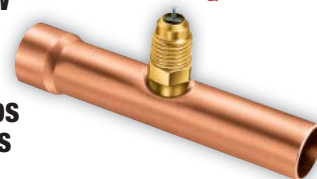

SEE PAGE 43 FOR FORGED BRASS TEES

PART NO.	CONNECTING LINE SIZE	A (OAL)	B (MIN)	BLISTER PKG.
A31199	1/4" OD	2-3/8"	5/16"	2
A31200	3/8" OD	2-3/4"	5/16"	2
A31201	1/2" OD	3"	3/8"	2
A31202	5/8" OD	3-1/4"	1/2"	2
A31204	7/8" OD	3-3/4"	3/4"	2

ACCESS VALVES

SWIVEL FLARE CONNECTION

Add multiple ports with just one fitting. These valves offer a safe, simple installation without the need for brazing. All of the flare ends are tapped to receive access core. JB provides a full range of various end configurations to provide greater flexibility. One core and cap are packaged with each valve.

TYPICAL SWIVEL FLARE INSTALLATION

Swivel flare with core depressor installed on existing access valve. Add a new line or control. No refrigerant loss on charged system.

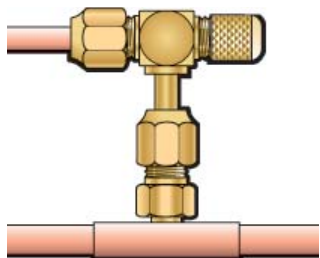

Valve without depressor installed on flare fitting. Multiple ports provide additional line or controls and access site.

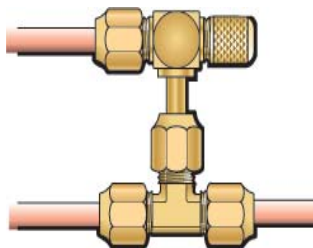

TYPICAL MPT INSTALLATION

All MPT connections have internal braze cup for dip tube installation.

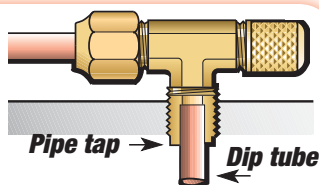

CROSS WITH THREE ACCESS PORTS

A31522



PART NO.	DESCRIPTION	BLISTER PKG.
A31522	1/8" MPT cross	1

MPT CONNECTIONS TEE

A31452
A31454



A31512
A31514



PART NO.	DESCRIPTION	BLISTER PKG.
A31452	1/8" MPT branch	3
A31454	1/4" MPT branch	3
A31512	1/8" MPT run	3
A31514	1/4" MPT run	3

MPT CONNECTIONS



PART NO.	DESCRIPTION	BLISTER PKG.
*A31482	1/8" MPT half union	5
*A31484	1/4" MPT half union	5
*A31492	1/8" MPT elbow	3
*A31494	1/4" MPT elbow	3

SWIVEL TEE WITH DEPRESSOR



A31851
A31864 (no depressor)



PART NO.	DESCRIPTION	BLISTER PKG.
A31851	1/4" Fe SAE swivel nut on run	3
A31852	1/4" Fe SAE swivel nut on branch	3

SWIVEL TEE WITHOUT DEPRESSOR



A31852
A31854 (no depressor)



PART NO.	DESCRIPTION	BLISTER PKG.
A31854	1/4" Fe SAE swivel nut on branch	3
A31864	1/4" Fe SAE swivel nut on run	3

SWIVEL 3/8" SAE TEE



A31853

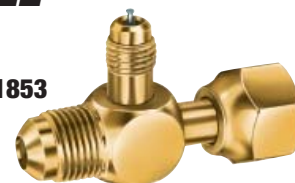

PART NO.	DESCRIPTION	BLISTER PKG.
A31853	3/8" SAE X 3/8" Fe SAE swivel nut X 1/4" access	1
A31856	3/8" SAE X 1/4" access X 3/8" Fe SAE swivel nut	1

ACCESS VALVES

SWIVEL CROSS WITH DEPRESSOR



A31520

PART NO.	DESCRIPTION	BLISTER PKG.
A31520	1/4" Fe SAE swivel nut x access	1

FLARED TUBE CONNECTION



A31424



A31444

PART NO.	DESCRIPTION	BLISTER PKG.
*A31424	1/4" Fe SAE union w/ flare nut	3
A31444	1/4" Fe SAE tee w/ nuts	3

*Core pre-torqued to ARI

FLARE CONNECTION AND FLARE FITTING ADAPTER

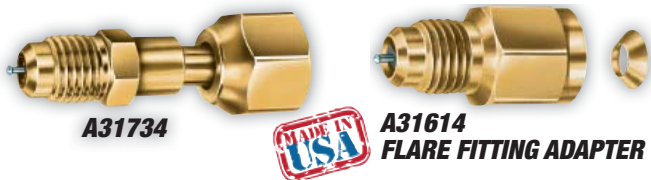

A31734



A31614
FLARE FITTING ADAPTER

PART NO.	DESCRIPTION	BLISTER PKG.
*A31614	1/4" Fe SAE w/ copper gasket	5
*A31734	1/4" Fe SAE swivel nut w/ depressor	3

*Core pre-torqued to ARI

BULKHEAD MOUNTING

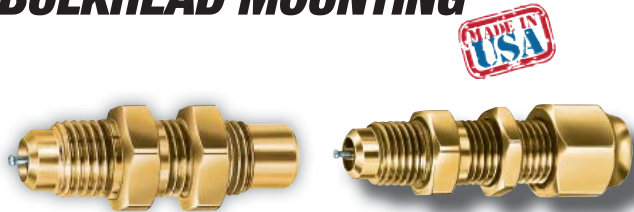

PART NO.	DESCRIPTION	BLISTER PKG.
*A31434	Access x 1/4" SAE w/ nut	1
*A31727	Access x 3/16" and 1/4" ODS or 3/8" ODF	1

*Core pre-torqued to ARI

FORGED BRASS BRAZE TEES



A31234

A31544

PART NO.	DESCRIPTION	BLISTER PKG.
A31234	1/4" ODS x 3/8" ODF	3
A31235	5/16" ODS x 3/8" ODF	3
A31236	3/8" ODS x 1/2" ODF	3
A31238	1/2" ODS x 5/8" ODF	3
A31544	1/4" ODS	3

BRASS BODIES



PART NO.	DESCRIPTION	BLISTER PKG.
A31722	1/8" ODS x 1/4" ODF	3
A31723	3/16" ODS x 1/4" ODF	3
A31724	1/4" ODS x 3/8" ODF	3
A31725	5/16" ODS x 1/2" ODF	3
A31726	3/8" ODS x 1/2" ODF	3
A31728	1/2" ODS x 5/8" ODF	3

MULTI STEP



PART NO.	DESCRIPTION	BLISTER PKG.
A31720	3/16" ODS x 1/4" or 3/8" ODF steps	5
A31729	3/16", 1/4", 5/16", 1/2" ODF steps	3
A31736	1/8" ODS x 3/16", 1/4" or 5/16" ODF	3

ACCESS VALVE COUPLER WITH DEPRESSOR



Quickly add controls or branch line to service valve. Valve core depressed when coupler is tightened.

PART NO.	DESCRIPTION	BLISTER PKG.
A33004	1/4" SAE swivel flare x male flare	1

ACCESS VALVES

SAE 45° BRASS FLARED TUBE FITTINGS



PART NO.	DESCRIPTION	BLISTER PKG.
A32600	1/4" (NS4-4)	10
A32601	5/16" (NS4-5)	5
A32602	3/8" (NS4-6)	10
A32603	1/2" (NS4-8)	5
A32604	5/8" (NS4-10)	5
A32605	3/4" (NS4-12)	2

SWIVEL FE FLARE X SOLDER ADAPTER

DOUBLE DEEP SOLDER CUTS



A32700-04

PART NO.	DESCRIPTION	BLISTER PKG.
A32700	1/4" x 1/4" (US5-44)	4
A32701	3/8" x 3/8" (US5-66)	4
A32702	1/2" x 1/2" (US5-88)	4
A32703	5/8" x 5/8" (US5-1010)	2
A32704	3/4" x 3/4" (US5-1212)	2

ACCESS VALVE SERVICE KIT

JB has taken the most popular access fittings used on service calls and created an access valve service kit with convenient storage case. Each kit is compartmentalized to house the following: A31002, A31003, A31004, A31005, A31006, NFT5-4, A31851, A31852, A32004 valve core tool with cores, plastic core removers, and A33500 thumbscrew core depressor. The interior of the label includes part numbers to make individual reordering and stocking convenient.



PART NO.	DESCRIPTION
AVK-001	Access valve service kit in storage case

BULK FITTING JARS

JB has taken a few of the best selling access valves and packaged them in a convenient display jar. Featuring individual labels with unique bar codes, the item can be scanned at the top of the jar rather than looking it up in the computer. Saves counter personnel time to directly sell single units without having to look up part numbers in the system. Order the jar once and restock as needed.



PART NO.	DESCRIPTION
A31004-CJ	1/4" OD X 3/16" ID copper tube extension with bulk jar (250 pcs.)
NFT5-4-CJ	1/4" SAE cap with bulk jar (500 pcs.)

EVACUATION AND CORE REMOVER TOOLS

Specifically designed to valve off the system to remove valve core, these tools feature a quarter turn ball valve shut-off and O-ring seals. The valve core can be completely removed and replaced without losing system charge. Speed-up evacuation, recovery, or recharging time through the full flow port. Both tools have a storage area to house spare valve cores.



A32500N

PART NO.	DESCRIPTION
A32500N	1/4" valve core remover
A32505N	5/16" valve core remover
A32525N	1/4" valve core remover w/ access port
A32530N	5/16" valve core remover w/ access port
A32501N	Core remover bit for A32500N replacement
A32504	Core remover bit for A32525N replacement

VALVE CORE TOOLS

EVACUATION CORE REMOVER AND SUPERHEAT THERMOMETER TOOL SET

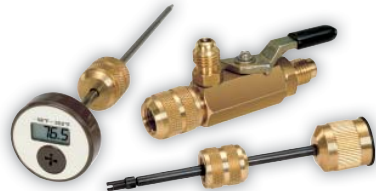

This combo set calculates superheat from -58°F to +302°F (-50°C to 150°C) with the temperature/pressure tool. All items have O-ring seals and the core remover tool has a quarter turn ball valve shut-off.

PART NO.	DESCRIPTION
A32550N	Evacuation core remover and superheat tool set
A32504	Core remover bit replacement part

EVACUATION RECOVERY TOOL



Our evacuation/recovery tool is a plier-type tool with a quick release trigger which punctures large holes into the line for discharge of a recovery unit. Fits 3/16" to 7/8" OD hard tubing.

PART NO.	DESCRIPTION
A32100	Evacuation/Recovery tool
A32101	Hardened steel needle and gasket

VALVE CORE TORQUE TOOL



The rotary torque mechanism prevents over-torquing of valve core. Reads in inch/lbs.

PART NO.	DESCRIPTION
32002	1/4" valve core torque tool
32003	Core remover bit replacement part

1/4" VALVE CORE TOOL



Complete with a hollow handle for storage of the 6 extra valve cores.

PART NO.	DESCRIPTION
A32004	1/4" valve core tool

VALVE CORE TORQUE TOOL

Our valve core torque tool automatically sets proper torque to 5" pounds. Calibrated to precise torquing requirements for core valves, the tool will no longer tighten once proper torque is achieved. Eliminates guess work which results in under and over torquing. Works with all Schrader valve cores.

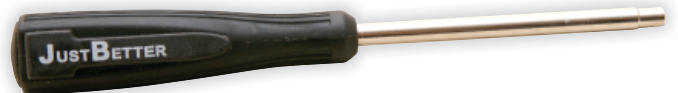

PART NO.	DESCRIPTION
A32008	Valve core torque tool
A32008-B	Valve core torque tool bulk (12 pack)
A32008-BX	Valve core torque tool in display box (12 pack)

EVACUATION RECOVERY TOOL

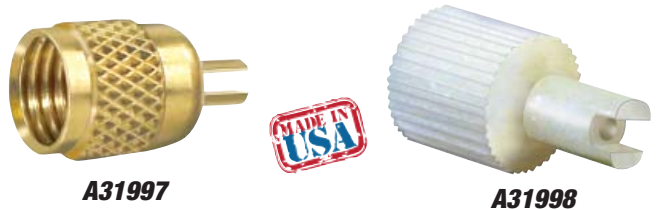

A31997 is a 1/4" SAE gasket seal cap with core remover feature. A31998 is a 1/4" plastic core remover.

PART NO.	DESCRIPTION
A31997	1/4" SAE gasket seal caps with core removers (10 pack)
A31998	1/4" plastic core removers (5 pack)

1/4" VALVE CORES



PTFE/ neoprene seal replacement valve core. Max 800 psi and 220°F (104°C).

PART NO.	DESCRIPTION
A31999	1/4" valve core (5 pack)
A31999-25	1/4" valve core (25 pack)
A31999-100	1/4" valve core (100 pack)

CAPS

O-RING QUICK SEAL CAPS



Deep Vacuum and A/C Refrigeration. Finger tight sealing for all male SAE connections.

PART NO.	DESCRIPTION
NFT5-4	1/4" SAE cap (10 pack)
NFT5-6	3/8" SAE cap (3 pack)
NFT5-8	1/2" SAE Cap (3pack)
NFT5-4-100	1/4" SAE cap (100 pack)
NFT5-6-100	3/8" SAE cap (100 pack)
P90010	Replacement 1/4" O-ring (5 pack)
P90011	Replacement 3/8" O-ring (5 pack)

QUICK SEAL GASKET CAPS



Deep Vacuum and A/C Refrigeration. Finger tight sealing for all male SAE connections.

PART NO.	DESCRIPTION
A31985	1/4" SAE cap (10 pack)
A31985-100	1/4" SAE cap (100 pack)
P509	Replacement gasket (6 pack)
P509-25	Replacement gasket (25 pack)

SPECIALTY CAPS AND 1/2" 16 ACME CAPS



PART NO.	DESCRIPTION
A31992	1/4" SAE cap (5 pack)
A31992-100	1/4" SAE cap (100 pack)
13493	Plastic cap with retainer strap (2 pack)
13494	Plastic cap (1 pack)

O-RING SEAL LINE PIERCING

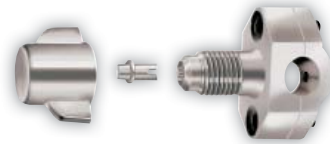

Our spring loaded needle automatically back-seats, forming a leak proof seal. A simple installation that is 100% restriction free. Both models fit 1/4", 5/16", 3/8", 1/2", and 5/8" OD tubing.

PART NO.	DESCRIPTION
LT-456	1/4" - 3/8" Line piercing valve
LT-810	1/2" - 5/8" Line piercing valve

E-Z TAPPER

The back-seating stem eliminates line restriction when servicing through access port or use the valve for flow control.



PART NO.	DESCRIPTION
EZ-40288	E-Z topper piercing valve
EZ-40288-126	E-Z tapper gasket (5 pack)

BACK SEATING CONTROL VALVE

Ideal for use on pre-charged line sets. Eliminates spraying of leak detection dye and refrigerant. Compact brass body for long service. Swivel coupler with double safety grooves.



PART NO.	DESCRIPTION
A33000	1/4" SAE x 1/4" O-ring quick coupler
P90009	Replacement O-ring (10 pack)

WRENCH STYLE SEAL CAP



For A/C Refrigeration service. Brass to brass positive seal and permanent installation.

PART NO.	DESCRIPTION
A31986	1/4" SAE cap (5 pack)

NOVENT® REFRIGERANT LOCKING CAPS



NOVENT®

ADDED TO THE 2009 IMC AND IRC SECTIONS OF BUILDING CODE

DETERS REFRIGERANT THEFT TO HELP REDUCE "HUFFING"

LOCKS AND UNLOCKS USING SPECIAL KEY SOLD ONLY TO CERTIFIED HVAC TECHNICIANS

COLOR-CODED PERMANENTLY STAMPED ALUMINUM CASING FOR EASY IDENTIFICATION HELPS PREVENT ACCIDENTAL MIXING OF REFRIGERANT

PATENT NUMBER 6,612,455

PREVENT REFRIGERANT THEFT

JB Industries is proud of our partnership with NOVENT®, enabling us to provide refrigerant locking caps to the HVAC/R market. NOVENT® was created by industry professionals after evidence of refrigerant theft, many times resulting in brain damage or death, after inhaling or "huffing" refrigerant. NOVENT® created the original tamper resistant refrigerant locking caps for the service valve on all air conditioning and mini split systems. NOVENT® caps are patented and precisely machined from high grade brass and encompassed within a protective refrigerant color-coded aluminum casing. These caps are corrosion resistant and have an O-ring seal to provide a positive back-up for leaking service valves. The caps are secured on to a unit with a special key sold only to certified HVAC technicians and provide a tamper resistant barrier to reduce theft, vandalism, and the accidental mixing of refrigerant. NOVENT® supports all EPA Management Programs. The products are a must for companies and technicians to comply with local codes, as well as liability concerns connected with refrigerants.

PART NO.	DESCRIPTION
NC-A31004	Universal cap on 1/4" extension (5 pack)
NCU-4	NOVENT® locking cap Universal (4 pack)
NCP-4	NOVENT® locking cap R-410A (4 pack)
NCG-4	NOVENT® locking cap R-22 (4 pack)
NCE-4	5/16" NOVENT® locking cap for R-410A mini split systems (4 pack)
NCU-12	NOVENT® locking cap universal (12 pack)
NCP-12	NOVENT® locking cap R-410A (12 pack)
NCG-12	NOVENT® locking cap R-22 (12 pack)
NCM-12	NOVENT® locking cap assorted (12 pack)
NCU-CJ	NOVENT® locking cap universal in display jar (150 bulk and jar)
NCE-12	12Pk Minisplit cap

PART NO.	DESCRIPTION
NCE-50	50Pk Minisplit cap
NCP-CJ	NOVENT® locking cap R-410A in display jar (150 bulk and jar)
NCG-CJ	NOVENT® locking cap R-22 in display jar (150 bulk and jar)
NCM-CJ	NOVENT® locking cap assorted in display jar (50 Universal, 50 R-410A, 50 R-22 and jar)
NCU-50	NOVENT® locking cap universal (50 bulk)
NCP-50	NOVENT® locking cap R-410A (50 bulk)
NCG-50	NOVENT® locking cap R-22 (50 bulk)
NC-KEY	Pocket key for all NOVENT® locking cap
NC-RS	Screwdriver style key for R-410A caps
NC-GS	Screwdriver style key for R-22 and universal caps

COUPLERS

QUICK COUPLERS

QC-S5

5/16" female x 1/4" male adapter is designed to give the end user the ability to connect their standard refrigeration hoses to 5/16" (1/2" UNF) fittings being used on most R-410A mini-splits. Swiveled so the adapter can remain on hoses for easy on/off application and installation.

3/8" couplers with patented O-ring seal for deep vacuum. No depressor.

3/16" couplers with valve core depressor, safety channels and O-ring seal.



QC-S5

For 410A 5/16" connections, use QC-S5.

1/4" and 5/16" couplers with valve core depressor, safety channels and rubber gasket seal.

STRAIGHT



QC-S3

PART NO.	DESCRIPTION
QC-S3	3/16" QC x 1/4" SAE
QC-S4	1/4" QC x 1/4" SAE
QC-S46	1/4" QC x 3/8" SAE
QC-S5	5/16" QC x 1/4" SAE
QC-S5S	5/16" QC x 1/4" SAE (no depressor)
QC-S64	3/8" QC x 1/4" SAE (no depressor)
QC-S65	3/8" QC x 5/16" SAE (no depressor)

FTP THREAD



QC-S4A

PART NO.	DESCRIPTION
QC-S4A	1/4" QC X 1/8" FTP
QC-S4B	1/4" QC X 1/4" FTP

ELBOW



QC-E3

PART NO.	DESCRIPTION
QC-E3	3/16" QC X 1/4" SAE elbow
QC-E4	1/4" QC X 1/4" SAE elbow
QC-E5	5/16" QC X 1/4" SAE elbow
QC-E64	3/8" QC X 1/4" SAE elbow (no depressor)

QUICK COUPLER SHUT-OFF FITTINGS

Use with existing charging hose. Immediately traps refrigerant discharge from hose when disconnected from access fitting.



PART NO.	DESCRIPTION
33112N	1/4" QC x 1/4" SAE
33113N	1/4" QC x 1/4" SAE 90°
33112RK	Replacement kit to rebuild
33112RKB	Replacement kit to rebuild(Old Style)

QUICK COUPLER ACCESS TEE

O-ring seal quick coupler. Furnished with cap and valve core.



PART NO.	DESCRIPTION
A34000	1/4" QC x 1/4" access branch tee
P90009	Replacement O-ring (10 pack)

SWIVEL CYLINDER VALVE

Finger tight seal. Includes gasket.



PART NO.	DESCRIPTION
CV-20004	3/4" NPS x 1/4" M flare
CV-20006	3/4" NPS x 3/8" M flare

CORE DEPRESSOR



PART NO.	DESCRIPTION
A33500	1/4" thumbscrew core depressor

REPLACEMENT PARTS FOR QUICK COUPLERS

PART NO.	DESCRIPTION
P90009	1/4" O-ring (10 pack)
P509	1/4" gasket (6 pack)
P90513	Depressor for 1/4" QC (5 pack)
P90012	3/8" O-ring (10 pack)

AUTOMOTIVE

134A AUTOMOTIVE COUPLERS

Quick connect/disconnect valve actuation without refrigerant venting. Safety sleeve holds coupler securely to service port. Color coded knobs.



PART NO.	DESCRIPTION
AC-13430	High side 90 degree snap coupler x 14 mm
AC-13435	Low side 90 degree snap coupler x 14 mm
AC-15530	High side 90 degree snap coupler x 1/4" SAE
AC-15535	Low side 90 degree snap coupler x 1/4" SA

134A AUTOMOTIVE QUICK ADAPTER

Retrofit existing SAE flare fitting for 134a auto service.



PART NO.	DESCRIPTION	QC GASKET
QC-S4A-134a	1/4" QC x 1/2" male ACME thread	P509
QC-13445-134a	1/2" ACME QC x 1/4" male flare	P510

1/2" ACME THREAD HALF UNION



PART NO.	DESCRIPTION
AF-13450	1/8" NPTF
AF-13451	1/4" NPTF
AF-13452	3/8" NPTF
AF-13455	1/4" Fe SAE
AF-13457	3/8" Fe SAE

SIDE TAP CAP

SCT-1050

The design of our side can tap allows you to easily adjust from R-12 to R134a refrigerant cylinders for quick and easy charging. Slide handles with proper collar around can and close to pierce. Do not use with other refrigerants. Features a 1/4" x 1/2" ACME thread fitting.

SCT-1050



1/2" ACME SERVICE VALVE



PART NO.	DESCRIPTION	Blister PKG.
AF-13550	1/2" ACME x 1/8" NPTF w/ 13494 cap	1

OIL TAP TUBE



A33600

End the mess in oil changes and save time on service calls with JB's oil tap access tube. This access tube reduces motor burnout by simplifying acid tests and can be left in place for future tests and changes.

PART NO.	DESCRIPTION
A33600	Oil tap tube
RG-33600	Replacement gasket

REFRIGERANT BALL VALVES

FULL FLOW BALL-REFRIGERATION

JB's ball-refrigeration valves have a large port design that provides a minimum pressure drop with straight through flow. Copper end fittings reduce installation time without disturbing valve. We have two types of ball valves to suit your needs. Our traditional ball valves have brass actuators and a working pressure rating of 500 psi. Our new addition ball valve features stainless steel actuators and a working pressure rating of 700 psi. We differentiate the two types here by "Brass" and "Steel". Both are UL listed.

BRASS NO. PORT.	STEEL NO. PORT.	BRASS WITH PORT.	STEEL WITH PORT.	DESCRIPTION
-----	V34350	-----	V34525	1/4" ODS extensions
V34200	V34300	V34400	V34500	3/8" ODS extensions
V34201	V34301	V34401	V34501	1/2" ODS extensions
V34202	V34302	V34402	V34502	5/8" ODS extensions
V34203	V34303	-----	-----	3/4" ODS extensions
V34204	V34304	V34404	V34504	7/8" ODS extensions
V34206	V34306	V34406	V34506	1-1/8" ODS extensions
V34207	V34307	V34407	V34507	1-3/8" ODS extensions
V34208	V34308	V34408	V34508	1-5/8" ODS extensions
V34209	V34309	V34409	V34509	2-1/8" ODS extensions
V34210	V34310	-----	V34510	2-5/8" ODS extensions
V34211	V34311	-----	V34511	3-1/8" ODS extensions



**STAINLESS STEEL ACTUATORS
PRESSURE TO 700 PSI
UL LISTED 32DC**



**BRASS ACTUATORS
PRESSURE TO 500 PSI
UL LISTED 57R7**

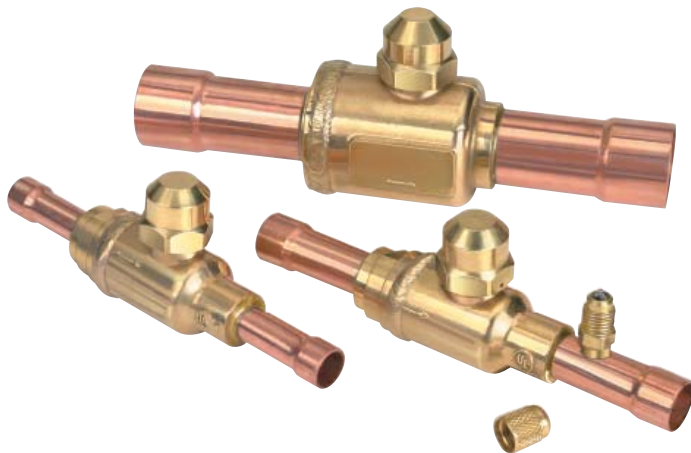

"BRASS" BALL VALVE FEATURES

- A. COPPER TUBE EXTENSIONS
- B. HERMETIC WELDED AND BRAZED JOINTS
- C. REINFORCED TEFLON SEATS
- D. ONE PIECE FORGED BRASS BODY
- E. BEARING WASHER
- F. CHANGEABLE REINFORCED PTFE STEM PACKING
- G. PACKING GLAND
- H. STEM CAP ASSEMBLY WITH NEOPRENE SEAL
- I. CHROMIUM PLATED BALL WITH VENTED VALVE

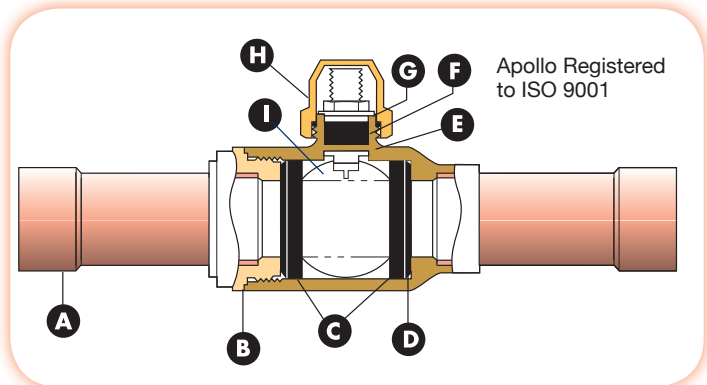

- 500 PSI WORKING PRESSURE
- UP TO +500° F WORKING TEMPERATURE AT 0 PSI
- UP TO +300° F WORKING TEMPERATURE AT 500 PSI
- NO BOLTED OR SCREWED BONNETS OR FLANGES TO LEAK

REFRIGERANT BALL VALVES

BI-DIRECTIONAL

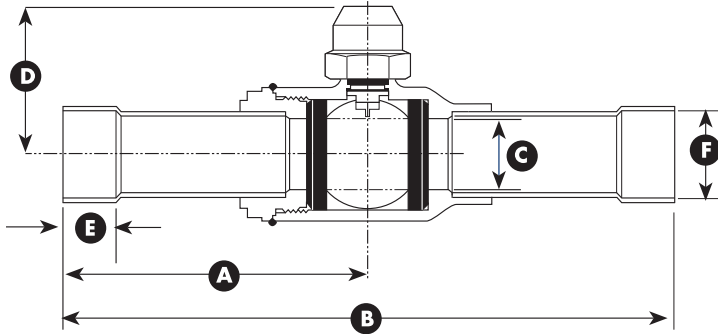

OPERATION

- A. Quarter turn mechanical stop. Positive open and closed positions.
 B. Packing gland adjusting nut.

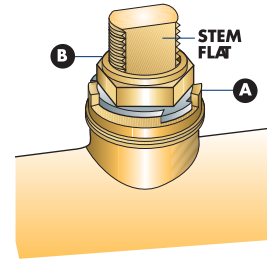

PART NO.	O.D. TUBE SIZE	CV(1)	EQUIVALENT LENGTH (2)	REFERENCE DIMENSIONAL DATA						
				A	B	C	D	E	F	
V34200 V34400	3/8"	2.90"	10.8"	3.18"	6.09"	0.30"	1.55"	3/8"	3/8"	
V34201 V34401	1/2"	5.60"	13.3"	3.18"	6.09"	0.45"	1.55"	3/8"	1/2"	
V34202 V34402	5/8"	13.10"	10.4"	3.43"	6.59"	0.50"	1.55"	1/2"	5/8"	
V34203 -----	3/4"	-----	-----	3.45"	7.27"	0.69"	1.89"	3/4"	3/4"	
V34204 V34404	7/8"	31.90"	11.2"	3.69"	7.07"	0.75"	1.83"	3/4"	7/8"	
V34206 V34406	1-1/8"	68"	10.7"	4.20"	8.00"	1.00"	2.01"	2-9/32"	1-1/8"	
V34207 V34407	1-3/8"	109"	11.6"	4.54"	8.63"	1.25"	2.61"	3-1/32"	1-3/8"	
V34208 V34408	1-5/8"	152"	13.2"	4.47"	8.85"	1.50"	2.79"	1-3/32"	1-5/8"	
V34209 V34409	2-1/8"	275"	15.1"	4.84"	9.59"	2.00"	3.17"	1-11/32"	2-1/8"	
V34210 -----	2-5/8"	349"	21.1"	5.00"	10.00"	2.43"	3.90"	1-31/64"	2-5/8"	
V34211 -----	3-1/8"	391"	30.1"	7.00"	14.00"	2.50"	3.90"	1-43/64"	3-1/8"	

1. This is the most commonly used flow coefficient by piping engineers in the design of piping systems. It is defined as "the number of US gallons of water per minute at 70° F (21° C) that will flow through a valve at a pressure drop (P1-P2) of 1 psi."

REFRIGERATION SHUT-OFF BALL VALVES

Ideal for building your own vacuum or charging system, our straight through flow design has no restriction. A quarter turn and the valve is fully open or closed.

PART NO.	DESCRIPTION
V34900	1/8" FPT x 1/8" FPT
V34910	3/8" FPT x 3/8" FPT



PART NO.	DESCRIPTION
V34901	1/4" SAE x 1/8" MPT
V34905	1/4" SAE x 1/4" MPT



2. Most engineers, contractors, and others engaged in the layout and installation of refrigeration and/or air conditioning systems will normally use the "equivalent length" method of determining the pressure drop through the systems. Since proper line sizing is critical to all installations, it is important to be able to determine the pressure drop through each component that makes up the system. "Equivalent length" figures are readily available through a number of sources for fittings, valves, etc.

NEEDLE VALVES

The packing used in the needle seat valves is resistant to gasoline, oils, and water while providing excellent sealing characteristics over the life of the valve. Metal to metal seating provides ease in shut-off to working pressures of 105 psi.

COMP X COMP

PART NO.	DESCRIPTION
NV62-4	1/4" x 1/4"

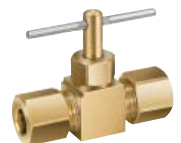



**IN EXCLUSIVE
PARTNERSHIP
WITH**



ROTHENBERGER
pipetool technologies at work

The partnership of **ROTHENBERGER** and JB brings together the best of German engineering and European craftsmanship with American distribution to create the highest quality tools in the HVAC/R marketplace. **ROTHENBERGER** tools are made of the highest quality materials and to the strictest quality standards to ensure that these tools will not fail when you need them the most. Backed by a 24 month over-the-counter warranty, JB and **ROTHENBERGER** are dedicated to standing behind their products. We have seen a tremendous growth and acceptance in the marketplace. Through the JB distribution channel, **ROTHENBERGER** is now available in over 900 HVAC/R branch locations nationwide. Once you get your hands on these tools, you can immediately feel the quality and see why **ROTHENBERGER** tools are Just Better. We are proud to present our collection for your review. Should you not see a particular tool of interest, please contact us at 800.323.0811 or email us at sales@jbind.com. The entire **ROTHENBERGER** product line and technical features can be viewed at our web site www.jbind.com.

MINI TUBE CUTTERS

Used for cutting copper tubes, these mini tube cutters have a large knurled knob and handy design to produce fatigue-free pressure control.



**RT70401/
RT70402**



RT70105



RT70015

PART NO.	DESCRIPTION
RT70401	Copper 1/8" to 5/8" OD
RT70402	Copper 1/4" to 7/8" OD
RT70105	Copper MINICUT 1/8" to 7/8" OD
RT70015	Copper MINI MAX 1/8" to 1-1/8" OD
RT70017B	Replacement cutter wheel (2 pack)
RT70017D	Replacement cutter wheel (5 pack)
RT70011	Replacement Axle Screw/Pin

**24 MONTH
WARRANTY**

ROTRAC PLUS

New JB precision tube cutters for copper tube are manufactured by **ROTHENBERGER** for JB and designed with smooth-running telescopic action for a consistent working radius. Features include a rolling stop which protects the cutter wheel, a protected screw spindle to shield against dirt and jamming, and a lightweight cast aluminum body. The deburrer swivels up, and the spare cutter wheel is stored in the handle, making them always within reach.



PART NO.	DESCRIPTION
RT70020	Copper tube 1/8" to 1-1/8" OD
RT70021	Copper tube 1/4" to 1-5/8" OD
RT70007B	Replacement cutter wheel (2 pack)
RT70007X	Replacement cutter wheel (10 pack)
RT99016	Replacement clip and axle

PROFESSIONAL TUBE CUTTER

For tubes made out of copper, brass, aluminum, this tube cutter features a retractable deburrer blade and a spare cutter wheel in the handle. The smooth adjustment knob allows for quick adjustment.



PART NO.	DESCRIPTION
RT70027	1/4" to 1-3/8" OD copper, aluminum pipe
RT70029	1/4" to 1-5/8" OD copper, aluminum pipe
RT21652B	Replacement deburring blade (10 pack)
RT70017B	Replacement cutter wheel (2 pack)
RT70017D	Replacement cutter wheel (5 pack)
RT70056D	Replacement cutter wheel for stainless steel (5 pack)

TUBING TOOLS

RATCHET TUBE CUTTER

For copper, brass, aluminum, thin-walled steel, and plastic coated tubes, this ratchet tube cutter has a retractable internal deburring tool and spare cutter wheel in the handle so they are always within reach. The ratchet telescopic guide with automatic spring-driven withdrawal allows for quick adjustment and fast opening.



RT70030

PART NO.	DESCRIPTION
RT70030	1/8" to 2-5/8" OD
RT70142	2" to 5" OD
RT70017B	Replacement cutter wheel for RT70030 (2 pack)
RT70017D	Replacement cutter wheel for RT70030 (5 pack)
RT70057D	Replacement cutter wheel for RT70142 (2 pack)
RT21652B	Replacement deburring blade (10 pack)

RO-GRIP RT70558

With a perfect grip and better leverage, our self-adjusting pliers offer many advantages over conventional pliers. Made of drop forged chrome vanadium steel, the rhombus-shaped jaws securely grab round, hex, sheets, and other shapes up to 1-5/8" OD.



RT70558

ROLOCK

Professional-grade water pump pliers with a jaw locking system providing a secure grip on round, square, or hex-shaped items with a push of a button. The ROLOCK has 14 groove opening positions with an opening capacity of 2-1/3".



RT70533

PART NO.	DESCRIPTION
RT70531	ROLOCK 7"
RT70532	ROLOCK 9"
RT70533	ROLOCK 12"

PIPE SHEARS

For precise cutting of PVC, PP, PE, PEX, PB, CPVC and PVDF, our pipe shears are the finest you can find. The quick release lever provides automatic opening of the blade at the push of a button. A double-sided stainless steel blade with v-shaped edges pierce the pipe to prevent deformation. The wide pipe rest ensures a square cut every time. A locking lever secures the blade during transport.

RT52010

RT52000



PART NO.	DESCRIPTION
RT52000	Max. OD 1-5/8", Sched. 40 PVC 1-1/4"
RT52010	Max. OD 2", Sched. 40 PVC 1-1/2"
RT52011	Replacement blade for RT52010
RT52042	Replacement blade for RT52000

WATER PUMP PLIERS

Complies with DIN 5321 D, these pliers are made with heavy-duty box joint, chrome vanadium steel, drop forged, tempered, and polished head and joint. The longer, thinner pliers with measurements for corners are ideal for hard to reach places. The self-clamping jaws will not slip, even on smooth surfaces.



RT70522

PART NO.	DESCRIPTION
RT70521	7" Pliers Max. 1" OD
RT70522	10" Pliers Max. 1-1/4" OD
RT70523	12" Pliers Max. 1-1/2" OD

DEBURRING TOOLS

Internal/External deburring tools for copper and plastic tubes.



RT11006

RT70075

RT21655

PART NO.	DESCRIPTION
RT11006	Copper and stainless steel internal/external reamer 1/8" to 1-5/8" OD
RT70075	Copper and stainless steel internal/external reamer 1/8" to 2" OD
RT21660	Deburring tool (blade non-replaceable)
RT21655	Deburring tool
RT21652B	Replacement deburring blade for RT21655 (10 pack)

TUBING TOOLS

ROBEND® H+W PLUS RT24504

For exact cold bending up to 180° of soft and hard copper, thin-walled coated copper, aluminum and brass, precision steel, and coated, seamless stainless steel tubes. Unique design provides bending without deforming the pipe. Guide shoes and formers are anti-stick for less friction and bending effort. Base plate can be attached to vice for easy, free-hand bending. Set includes bending spray, 1/2", 5/8", 7/8" formers and steel carry case.



RT24504

TUBE BENDER SET RT24134

The ratchet feed of this tube bender is ideal for rapid, exact bending of small diameter soft copper and aluminum up to 90°. Designed for one hand operation, the compact design fits in even the tightest spaces. The open bending frame allows for the production of repeated alternate angled bends. Set includes bending tool, formers for ODs of 1/4", 5/16", 3/8", 1/2", and steel case.



RT24134



MINIBEND® TUBE BENDER RT25151

For exact, two-handed bending up to 180° for tubes made out of soft copper, brass, aluminum, and precision steel. 1/4", 5/16", and 3/8" OD.



RT25151

HAND TUBE BENDER RT90614

This universal hand bender provides bending of 1/2", 5/8", 3/4" and 7/8" OD soft copper, aluminum, and light grade stainless steel tubing.



RT90614

MAXI TUBE BENDER SET RT23022

The smooth-running feed lever of this tube bender makes it ideal in restricted spaces and one-handed operations. The side lever allows for quick release and reset of bending former. The pliers feature a bayonet catch to easily change bending formers. The open bending frame makes it possible to repeatedly produce alternate angled bends. The set consists of the basic tool, bending support, bending formers, and steel case. For use on copper and soft aluminum 3/8", 1/2", 5/8", 3/4", and 7/8" OD.



RT23022



STANDARD TUBE BENDER RT25140

For exact bending radius up to 180° for tubes made up of soft copper, aluminum, and precision steel. The light construction results in fatigue-free hand operation. The clamp mechanism better holds the tube and enables the bending of even the shortest of tube pieces. The Tube Bender Pro is for 1/2" and 3/4" semi-hard and hard copper pipes and features a case iron body for longer life along with self adjusting shoe.



RT25140

PINCH-OFF TOOL T21294

This plier-type pinch-off tool temporarily closes off line while making repairs. The quick release trigger and rounded jaws prevent cutting while allowing for reopening and rounding using a standard flare bar. For 1/8" to 5/8" OD (1/8" to 1/2" Nominal).



PART NO.	DESCRIPTION
RT25140	1/4" OD radius (0.71")
RT25131	5/16" OD radius (0.95")
RT25913	Tube Bender Pro 1/2" OD radius
RT25914	Tube Bender Pro 3/4" OD radius
RT25142	1/2" OD radius
RT25136	5/8" OD radius (2.28")

TUBING TOOLS

SPRING TYPE TUBE BENDER

Ideal for irregular bends, these spring type benders are available in single springs and packaged sets. Used for soft copper, aluminum, brass, and steel.



PACKAGED SETS

PART NO.	DESCRIPTION
BS-55	1/4", 5/16", 3/8", 1/2", and 5/8" in pouch
BS-77	All seven sizes in pouch

SINGLE SPRINGS



PART NO.	TUBE OD	NOM
BS-4	1/4"	1/8"
BS-5	5/16"	-----
BS-6	3/8"	1/4"
BS-7	7/16"	-----
BS-8	1/2"	3/8"
BS-10	5/8"	1/2"
BS-12	3/4"	5/8"

SINGLE SIZE SWAGE SIZE STAMPED OD AND NOMINAL



PART NO.	TUBE OD
T21002	1/8"
T21003	3/16"
T21004	1/4" Nom. 1/8"
T21005	5/16"
T21006	3/8" Nom. 1/4"
T21007	7/16"
T21008	1/2" Nom. 3/8"
T21010	5/8" Nom. 1/2"
T21012	3/4" Nom. 5/8"
T21014	7/8" Nom. 3/4"
T21018	1-1/8" Nom. 1"

PACKAGED SET T21024

Packaged swage set. Tube OD 1/4", 3/8", 1/2", and 5/8". The nominals are 1/8", 1/4", 3/8", and 1/2".

MULTI-SWAGE T21000

T21000 consists of three pieces that work with OD sizes including 3/16", 3/4", and 7/8" producing perfect solder cups for 9 OD tube sizes. OD sizes are 3/16", 1/4", 5/16", 3/8", 7/16", 1/2", 5/8", 3/4", and 7/8". Nominal 1/8", 1/4", 3/8", 1/2", 5/8", and 3/4".



MULTI-SWAGE T20095

Handy all-in-one tool. T20095 is a single piece that works with 1/4", 5/16", 3/8", 7/16", 1/2", and 5/8" OD.



45° FLARE/SWAGE T20275

Heavy-duty wide-range bar type flaring tool. The rugged, forged steel slip-on self centering yoke has a hardened chrome plate swivel type cone to form quality flares with minimal effort. Hardened bars provide positive clamping action with minimum distortion and are fully hinged with king-sized forged steel wing nuts for easy use. The second bar extends our flaring tool to 9 OD tube sizes.



PART NO.	TUBE OD	NOM.
T20275	Flare: 1/8", 3/16", 1/4", 5/16", 3/8", 7/16", and 3/4" Swage: 3/16", 1/4", 5/16", 3/8", 1/2", 5/8", and 3/4"	Nominal Flare: 1/8", 1/4", 1/2", 5/8" Nominal Swage: 1/8", 1/4", 3/8", 1/2", and 5/8"

TUBING TOOLS

FLARING TOOLS



T20195



RT222402



RT222601

PART NO.	TUBE O.D.
T20195	3/16", 1/4", 5/16", 3/8", 7/16", (nom. 1/8", 1/4", 3/8", and 1/2")
T20203	5/8", 3/4", 7/8", and 1-1/8" OD
T20500	3/16", 1/4", 5/16", 3/8", 1/2", and 5/8" OD
RT222402	1/8", 1/16", 1/4", 5/16", 3/8", 1/2", 5/8", 3/4" OD
RT222601	Adjustable from 3/16" to 5/8" OD

45° FLARING TOOL RT26036 SINGLE FLARE

For making precise 45° flares on copper, brass, aluminum, and precision steel tubes up to 0.04" (1 mm) in wall thickness. The special screw thread allows proper, efficient handling of material.

The "Multiblock" multi-clamping calipers provide a firm, quick off-center clamping of the tube and automatic self-centering. Flares 3/16", 1/4", 5/16", 3/8", 1/2", and 5/8".

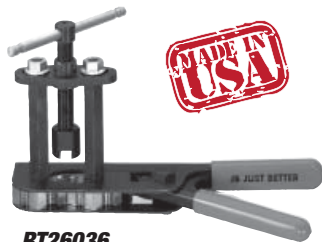

RT26036

SWAGING KIT RT26715

For precise 45° single flares and sockets on copper, brass, aluminum, and steel tubes. Set includes flaring tool, 45° cone, expander pin, internal/external deburrer, tube cutter, and plastic case. Includes swages for 3/16", 1/4", 5/16", 3/8", 1/2", and 5/8".



RT26715

TEE EXTRACTOR SET RT22124

Extract your own tees on soft, semi-hard and hard copper or aluminum and save time and money saved on T-pieces. The ergonomic, compact design fits into the tightest spaces. The set includes tee-extractors for 1/2", 5/8", 7/8" and 1-1/8", ratchet handle, cam pincer, high-speed drill, and steel case.



RT22124



TUBE EXPANDER KIT RT12318

The high strength, forged aluminum body make for lower weight and easy handling of our expander set. The longer lever arms reduce effort and the automatic pin guide retracts for faster operation. The set includes expander with riveted expander heads in 3/8", 1/2", 5/8", 3/4", 7/8", and 1-1/8", internal/external deburring tool, steel case. Replacement heads are interchangeable with Yellow Jacket and Ridgid tube expanders.



RT12318



TUBING TOOLS

ROPRESS PRESS TOOLS

CORDED AND CORDLESS PRESS TOOL

The ROPRESS is a 12-ton dieless state-of-the-art crimping tool. The dieless tool greatly simplifies the crimping of color coded lugs and splices. There are no dies to select. Featuring a 24,000 pound crimp force and weighing 15 pounds, both the corded and cordless versions offer maximum force with minimal effort. The Cordless ROPRESS has an 18 volt Lithium-Ion battery that lasts longer than NiMH batteries and weighs less. Interchangeable crimping jaws are flexible and cost effective. The LED display shows tool information while the sleek lightweight pistol design offers effortless repeated crimping. The Corded ROPRESS requires no batteries and delivers the same quality crimping as the cordless version. Both tools are compatible with Viega, Elkhart and NIBCO press fittings. Please see "Information Sheets" under the Technical section at www.jbind.com to view compatibility statements from each company. Press rings are available in 2-1/2", 3", and 4" upon request.



ROPRESS COMPACT COMPACT CORDLESS PRESS TOOL

The ROPRESS Compact light-weight, battery-powered press tool weighs only 5.4 lbs and connects 1/2", 3/4", and 1" copper tube and fittings in about 6 seconds. The slim profile allows one hand operation of the tool leaving the other hand free to hold and position the fitting. The 350° rotation of the jaw fixture and slim design easily reaches into tight spaces. When a press is complete, the jaws automatically release signaling

the tool is ready for the next press. The ROMAX Pressliner is compatible with Viega, Elkhart, and NIBCO press fittings. Please see "information sheets" under the Technical section at www.jbind.com to view compatibility statements from each company.



PART NO.	DESCRIPTION
RT16001	Compact tool only NO jaws
RT16002	Compact press tool, 3 copper jaws 1/2", 3/4", 1", battery, charger
RT15031V	Compact press jaw 1/2" copper
RT15032V	Compact press jaw 3/4" copper
RT15033V	Compact press jaw 1" copper
RT52176	18V Lithium battery, 3 amp
RT52178	18V Lithium battery charger, 120V

PART NO.	DESCRIPTION
RT16101	Cordless tool only NO jaws
RT16102	Cordless tool, 6 copper jaws 1/2", 3/4", 1", 1-1/4", 1-1/2", and 2", battery and charger
RT16201	Corded Tool, NO jaws
RT16202	Corded tool, 6 copper jaws 1/2", 3/4", 1", 1-1/4", 1-1/2", and 2"
RT15222X	Press jaw 1/2" copper
RT15223X	Press jaw 3/4" copper
RT15224X	Press jaw 1" copper
RT15225X	Press jaw 1-1/4" copper
RT15226X	Press jaw 1-1/2" copper
RT15227X	Press jaw 2" copper
RT52176	18V Lithium battery, 3 amp
RT52178	18V Lithium battery charger 120 V

FIN STRAIGHTENERS

T20352

Stainless steel fin straightener.



T20351

For 8, 9, 10, 12, 14, and 15 spacings per inch.



T20353 Stainless steel fin straightener with larger, easy to grip handle.



TUBING TOOLS

BRAZE-RITE ADAPTER

BRZ-1000

Nitrogen purging adapter for ACR pipe. Quickly connects to manifold gauge hose, and slips easily and securely into pipe. Allows for bleed of nitrogen through pipe being brazed, keeping the pipes clean and oxide-free. Stepped to fit most common ACR pipe sizes, making it fast to go from one tube to the next. Saves time and money and helps maintain equipment manufacturer's system performance and installation guidelines. No more duct taping your hose to the pipe!

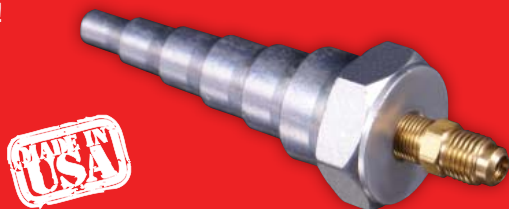

OIL TRANSFER PUMP

T30251

Designed to pump oil into the system while unit is operating without shutting down for charging. Smoothly pumps oil into the compressor on the down stroke while system is under pressure resulting in easier pumping on the positive stroke. The universal tapered rubber adapter is designed to fit all 1, 2-1/2, and 5 gallon containers without additional adapters. Works against 200 psi of pressure and is compatible with all oil types including synthetic, mineral, and polyol ester. Pumps 2.6 ounces (78 ml) per stroke.



GAS PRESSURE TEST KIT

This diaphragm gauge scale comes complete in case with hose and hook-up fitting.



PART NO.	DESCRIPTION
29435	Natural and LP gases. Scales 0-20 oz/sq. in.; 0-35" of water column
29436	Natural gas only. Scales 0-6 oz/sq. in.; 0-10" of water column

SERVICE WRENCHES

Double end reversible ratchet wrenches feature accurately broached multiple openings and offer the greatest number of uses in a single unit. Choose offset or hex and square ends. Items ending in "U" denote Made in the USA.



PART NO.	DESCRIPTION
T21124U	3/16", 1/4" square end and 1/2", 9/16" hex port end
T21127	1/4", 3/16" on one end 3/8", 5/16" on other end
T21127U	1/4", 3/16" on one end 3/8", 5/16" on other end
T21126U	Offset 1/4", 3/16" on one end 3/8", 5/16" on other end
T21125U	3/8" square end and 1/2" square end

HEX KEY ADAPTER T2-HKA

Heat treated black oxide plated hex key adapter for accessing liquid and suction based valves. Works for 3/16" and 5/16" hex valves.



STEEL STRAP

Our Steel Straps are zinc plated and alternate between nail and bolt holes.

PART NO.	DESCRIPTION
PS-10	10' (3 m) steel strap
PS-25	25' (7.6 m) steel strap
PS-50	50' (15 m) steel strap
PS-100	100' steel strap



GAS TEST GAUGE

To test system pressure for leaks in new installs, use these 3-1/2" easy to read test gauges. Fits 3/4" and 1" pipes.



PART NO.	DESCRIPTION
GTBG-12	3-1/2" test gauge 0-30 lb. 3/4" end
GTBG-16	3-1/2" test gauge 0-30 lb. 1" end

CAP TUBE

ACID BRUSHES

Our acid brushes are ideal for thread sealant, flux, and past solders. Made of 100% long and stiff horsehair bristles that are evenly placed and securely crimped into tinned acid-resisting handles.

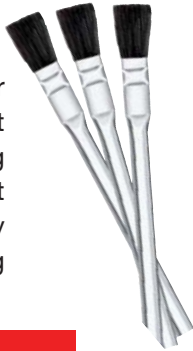

PART NO.	DESCRIPTION
C33804	1/4" flux brush (12 pack)
C33808	1/2" flux brush (10 pack)
C33808-CTN	1/2" flux brush (144 bulk)

GAUGE FILE AND CUTTING TOOL A10971 CAP TUBE AND FILE IN POUCH A10972 CAP TUBE FILE

Precision engineered with stainless steel wire plugs. Features a specially designed file to cut and open tubes. The numbers are etched in black for better legibility. Fourteen ID sizes from 0.026 to 0.090 and 22 OD sizes from 0.072" to 7/16" (5 to 12 mm). Use both the ID and OD calibrations to correctly determine tube size. Place tube in "V" slot to measure OD. Pin gauge measures ID. The cap tube file is designed to cut and open the tube by filing a notch around the tubing at desired cutting point. Snap tube by bending at the notch and clean burrs by reaming out with the special file tip.

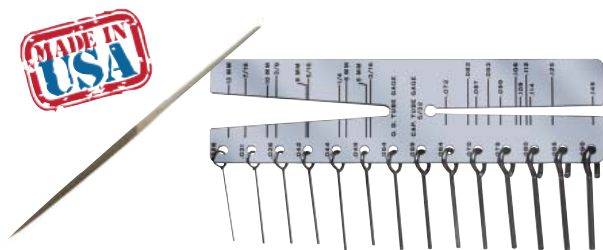

CAP TUBE CUTTING TOOL A10973

The sturdy design of our cap tube cutter results in no collapsing of the tube, clean cuts, and no chips.



CAPILLARY TUBING

Short coils are boxed with application charts. Cut from 100' (30.5 m) sealed and dehydrated tube.

S/B 100' (30.5 m) coils are boxed with conversion and application charts.



Available in cartons of 10. Add suffix -101 to part number.



SHORT COIL	100' COILS	DESCRIPTION
TC-26-16	TC-26-100	0.026 ID x 0.072 OD x 16' (BC-5, GC-5)
TC-31-12	TC-31-100	0.031 ID x 0.083 OD x 12' (BC-1, GC-1)
TC-36-12	TC-36-100	0.036 ID x 0.087 OD x 12' (GC-6)
TC-42-12	TC-42-100	0.042 ID x 0.093 OD x 12' (BC-2, GC-2)
TC-44-12	TC-44-100	0.044 ID x 0.109 OD x 12'
TC-49-11	TC-49-100	0.049 ID x 0.099 OD x 11' (BC-3, GC-3, GC-7)
TC-50-11	TC-50-100	0.050 ID x 0.114 OD x 11'
TC-54-11	TC-54-100	0.054 ID x 0.106 OD x 11' (GC-8)
TC-55-11	TC-55-100	0.055 ID x 0.125 OD x 11'
TC-59-10	TC-59-100	0.059 ID x 0.112 OD x 10'
TC-64-10	TC-64-100	0.064 ID x 0.125 OD x 10' (BC-4, GC-4)
TC-70-12	TC-70-100	0.070 ID x 0.125 OD x 12' (GC-9)
TC-75-9	TC-75-100	0.075 ID x 0.125 OD x 9' (GC-10)
TC-80-10	TC-80-100	0.080 ID x 0.145 OD x 10' (GC-11)
TC-85-9	TC-85-100	0.085 ID x 0.145 OD x 9' (GC-12)
TC-90-7	TC-90-100	0.090 ID x 0.145 OD x 7'
TC-100-10	TC-100-100	0.100 ID x 0.156 OD x 10'

Pressure/Temperature charts can be found on our website at www.jbind.com under "Instruction Sheets". Please see the "Copper Capillary Tubing" section for the conversion charts.

CAP TUBE

CAP TUBE LENGTH CONVERSION CHART

Part No.	TC-26	TC-31	TC-36	TC-42	TC-44	TC-49	TC-50	TC-54	TC-55	TC-59	TC-64	TC-70	TC-75	TC-80	TC-85	TC-90
Tube ID	0.026 ID	0.031 ID	0.036 ID	0.042 ID	0.044 ID	0.049 ID	0.050 ID	0.054 ID	0.055 ID	0.059 ID	0.064 ID	0.070 ID	0.075 ID	0.080 ID	0.085 ID	0.090 ID
0.024	1.44															
0.025	1.20															
0.026	1.00	2.24														
0.028	0.72	1.59														
0.030	0.52	1.16														
0.031	0.45	1.00	2.00													
0.032		0.86	1.75													
0.033		0.50	1.54													
0.034		0.65	1.35													
0.035		0.58	1.16	2.31												
0.036		0.50	1.00	2.10												
0.037		0.45	0.90	1.79	2.22											
0.038		0.39	0.80	1.59	1.92											
0.039		0.31	0.71	1.41	1.75											
0.040		0.28	0.62	1.25	1.55	2.51										
0.041		0.25	0.56	1.12	1.38	2.26	2.50									
0.042		0.23	0.50	1.00	1.24	2.03	2.23									
0.043		0.20	0.45	0.87	1.11	1.83	1.98									
0.044			0.39	0.81	1.00	1.62	1.79									
0.045			0.35	0.73	0.90	1.47	1.60	2.32								
0.046			0.32	0.67	0.82	1.34	1.47	2.08	2.27							
0.047				0.59	0.74	1.20	1.31	1.89	2.06							
0.048				0.54	0.67	1.10	1.20	1.72	1.87							
0.049				0.49	0.61	1.00	1.09	1.55	1.69							
0.050				0.45	0.56	0.91	1.00	1.43	1.56	2.14						
0.051				0.41	0.51	0.84	0.90	1.31	1.44	1.96						
0.052					0.47	0.76	0.85	1.19	1.32	1.78						
0.053					0.43	0.69	0.78	1.09	1.20	1.64						
0.054					0.39	0.65	0.70	1.00	1.09	1.52	2.18					
0.055					0.36	0.59	0.64	0.92	1.00	1.38	2.00					
0.056						0.54	0.60	0.85	0.94	1.27	1.85					
0.057						0.50	0.55	0.79	0.87	1.17	1.72					
0.058						0.46	0.51	0.73	0.80	1.07	1.56					
0.059						0.42	0.47	0.67	0.73	1.00	1.44	2.18				
0.060						0.39	0.43	0.62	0.67	0.93	1.33	2.04				
0.064							0.32	0.47	0.50	0.69	1.00	1.50	2.07			
0.070								0.30	0.33	0.46	0.67	1.00	1.37	1.84		
0.075											0.48	0.73	1.00	1.37	1.75	
0.080												0.54	0.74	1.00	1.32	1.71
0.085													0.57	0.76	1.00	1.29
0.090														0.62	0.76	1.00
0.095														0.46	0.60	0.79
0.100															0.48	0.62
0.105																0.49

TO USE CHART

1. Locate recommended cap tube ID in left column.
2. Read across and find conversion factor under copper cap tube size.
3. Multiply the given length of the cap tube by the conversion factor.
4. The resultant length of the cap tube will give you the same flow characteristics as the original recommended cap tube.

EXAMPLE: Locate 0.040 in left hand column and reading across gives the following conversion factor: No. TC-36 cap tube (0.036 ID) -0.62 and No. TC-42 cap tube (0.042 ID) -1.25. Multiply the recommended cap tube length of 9' by the conversion factor gives the following results: 5.5' - 0.036 ID and 11.25 - 0.042 ID. Either of these two cap tubes will give the same results as the original cap tube of 9' -0.40 ID.

Every precaution should be taken to prevent chips, dirt, flux, moisture, etc., from entering the system when changing the cap tube. Most cap tube has very small holes that do not require much debris to plug flow.

The size of the cap tube is critical to its application. While some variation from the ideal can be tolerated, it is important to understand those factors which the service engineer can control. Unlike orifices such as expansion valve seats, capillary tubing depends on its length as well as its diameter to determine the total restriction. A change in diameter on a percentage basis can change the flow more than an equal change in length. For example, changing the diameter by 0.005" as between 0.026" ID and 0.031" ID can double the flow.

The length of the cap tube is the one factor over which the service engineer has the easiest and most immediate control. The best known method of changing the restriction of a cap tube is to change its length. Cut off a piece and its restriction is reduced. Substitute a longer tube and increase the restriction. However, there are factors that are not generally understood that limit the amount of lengthening or shortening.

As a general rule, keep the cap tube no shorter than 5 feet and no longer than 16 feet to eliminate many problems. Only plug drawn capillary tubing should be used in refrigeration and air conditioning application. JB capillary tubing is drawn to a plus or minus 0.001" on the ID, the finest attainable. Therefore, we recommend using JB cap tubing and the application charts included in the packaging.

The "Capillary Tubing Length Conversion Chart" was developed to enable users of capillary tubing to use standard tubing sizes which are widely available. While many OEMs recommend specific lengths and diameters of cap tube for their units, these tube sizes are not always readily available and may have to be special ordered.

This conversion chart enables the user to translate the recommended length into that of a tube diameter that can be quickly obtained. In using the chart, it is recommended that conversions be made using factors within the shaded area. In addition, it is highly recommended that the minimum length of capillary tubing used is 5 feet.

LA-CO PRODUCTS

COOL GEL™ HEAT DISSIPATING SPRAY 11509

Heat dissipating spray helps prevent heat damage to components and surrounding materials during soldering, brazing, and welding. It protects painted and finished surfaces from discoloration due to adjacent torch operations. This product also reduces the danger of fire to surrounding surfaces such as studs, drywall, and insulation. The unique non-staining gelled formula sticks to surfaces without dripping or running off and leaves no residue. Safe, non-toxic, and odorless spray liberally on adjacent surfaces needing protection. The spray pattern is adjustable from stream to mist. One quart spray bottles sold in cases of 12.



VALVE ACTION™ PAINT MARKER 96822 Red 96823 Black



This long-lasting, weather-, water-, and UV-resistant paint marker dries in 3 minutes. Marks on all surfaces including metal, wood, glass, plastic, rubber, cardboard, and paper. Lead-free paint meets California VOC regulations. Marking range is -50° F to 150° F (-46°C to 66°C). Sold in bulk cases of 12.

SLIC-TITE® PASTE WITH PTFE 42019

Premium thread sealant for sealing water, air, steam, natural gas, LP gas, refrigerants, ammonia, gasoline, and oil. For use on metal, PVC, CPVC, and ABS plastic threads. Do not use on Oxygen service, use PTFE tape or LA-CO Oxytite®. Sealing temperature -50° F to 500° F (-46° C to 260° C). Pressures 3,000 psi (204 bar) for gas, 10,000 psi (680 bar) for liquid. NSF, UPC, CSA, cULus, FGG/BM/CZ approved. 1/2 pints sold in cases of 12.



PIPETITE-STIK® 11175



Non-toxic and lead-free, the Pipetite Stik® is for use for water, steam, air, natural gas, and LP gas. Use on metal threads. Do not use on Oxygen service; use PTFE tape or LA-CO Oxytite®. Sealing temperature is up to 350° F (177° C) and pressures to 2,000 psi (136 bar) for liquids and 350 psi (24 bar) for gasses. Certified by NSF to meet ANSI/NSF Standard 61 for use on potable water. 1-1/4 Oz. sticks sold in cases of 12.

HEAT-SEAL STIK® PREMIXED EPOXY SEALER 11575



Ideal for use on high and low side of refrigeration systems, the Heat-Seal Stik® can be used on aluminum, copper, other metals, glass, and ceramics. Works on R-410A based systems. Sticks, melts, seals, and cures in one 90 second operation. One part epoxy, there is no mixing or measuring needed. Sealing temperature is up to 350° F (177° C) and pressures to 450 psi (31 bar). 3/8 Oz. sticks sold in cases of 12.

BLOC-IT® HEAT ABSORBING PASTE 11511

Heavy paste effectively absorbs surface heat and protects adjoining surfaces that may be damaged by excessive heat. Typically used to protect rubber, plastic, distortion, painted and finished surfaces during soldering, brazing or welding. Safe to use, Bloc-It® is non-toxic, harmless to skin, odorless, and does not contain asbestos. Wipe off with cloth or wash with water, Bloc-It® will not leave stains. 10 oz. tubes sold in cases of 24.



BRASS FITTINGS

JB's American made brass SAE 45° flared tube fittings may be used with copper, brass, aluminum, steel, and plastic tube provided an acceptable flare could be generated with the material.

Vacuum and pressures of 5,000 psi can be handled depending upon the size, material, and conditions. Using a 4:1 safety factor, the following general rule (excluding plastic tube) is used:

- 3,000 psi to 1/4"
- 2,000 psi to 1/2"
- 1,500 psi to 1"



Long nuts are recommended when vibration is a factor. Tubing should be double flared in extreme applications to minimize flare thinning on over-tightening.

Fittings listed generally comply with SAE, ASA, ASME, and MS standards; however, when design makes dimensions critical, please contact us at 800.323.0811 for samples and/or prints for testing and evaluation.

Tube sizes listed are OD (outside diameter). To determine nominal (water tube) size, subtract 1/8", thus 5/8" OD equals 1/2" nominal.

Pipe sizes listed are standard nominal pipe size and threads are to Dryseal Taper Pipe Standards.

JB will provide flare fitting to SAE Standard J513 whenever possible. In some cases, slight deviations will occur when full compliance fittings are not available.

- **Make and break**
- **Good vibration resistance (improved by using long nuts)**
- **Low cost**
- **Easy assembly**
- **Wide selection**

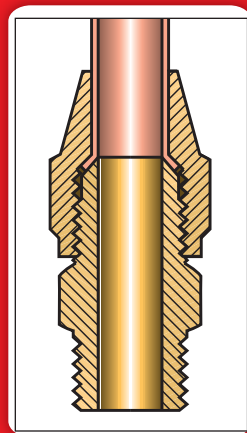

Heavy-duty ACR tube fittings generally conform to SAE, ASA, and ARI Standards for hydraulic, marine, and refrigeration service. Long dryseal pipe threads minimize leakage and provide more clearance for tightening flare nuts. Shapes, elbows, tees, etc., are made from brass forgings to maximize strength and eliminate cracks.

ASSEMBLY INSTRUCTIONS

1. Cut tube square and remove cut-off burr
2. Slide nut on tube, threaded end facing end of tube
3. Flare tube following flaring tool manufacturers instructions (check flare quality)
4. Thread nut on to fitting body "hand tight"
5. With proper wrench, tighten to a solid feel

CAUTION: Over tightening and dirt can damage fittings and/or tube causing leaks.

NOTE: Lubrication of flare faces and threads is recommended when practical.

THREAD SIZE OF TUBE ENDS

O.D. TUBE	SAE/FLARE	O.D. TUBE	SAE/FLARE
1/8"	5/16-24	1/2"	3/4-16
3/16"	3/8-24	5/8"	7/8-14
1/4"	7/16-20	3/4"	1 -1/16-14
5/16"	1/2-20	7/8"	1 -1/4-12
3/8"	5/8-18	1"	1 -3/8-12
7/16"	11/16-16	----	-----

TORQUE POUNDS FOR FLARE FITTING (DRY THREAD)

SIZE	FT. LBS
1/4"	8-10
3/8"	15-25
1/2"	25-35
5/8"	40-55
3/4"	50-60

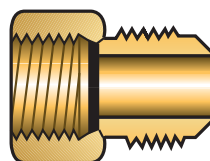

Copper Seal gaskets (B2) series furnished with all female flares.

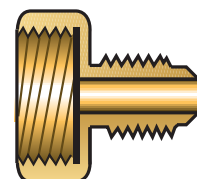

Fiber gaskets (K1 and D/E) furnished with all drum adapters (K1-1 through 8).

BRASS FITTINGS

Copper Flare Bonnet

Use with Flare nut to cap a fitting.



PART NO.	SIZE	PKG.
B1-3	3/16"	5
B1-4	1/4"	25
B1-6	3/8"	5
B1-8	1/2"	5
B1-10	5/8"	10
B1-12	3/4"	5

Copper Flare Gasket

Used on brass to brass or brass to steel connections to prevent leaks.



PART NO.	SIZE	PKG.
B2-3	3/16"	5
B2-4	1/4"	25
B2-5	5/16"	5
B2-6	3/8"	25
B2-8	1/2"	25
B2-10	5/8"	10
B2-12	3/4"	10

Cross



PART NO.	SIZE	PKG.
C1-4	1/4"	2
C1-6	3/8"	2

Flare x Male Pipe Ell



PART NO.	SIZE	PKG.
E1-2A	1/8" x 1/8"	5
E1-3A	3/16" x 1/8"	2
E1-4A	1/4" x 1/8"	10
E1-4B	1/4" x 1/4"	10
E1-4C	1/4" x 3/8"	5
E1-5A	5/16" x 1/8"	5
E1-5B	5/16" x 1/4"	5
E1-5C	5/16" x 3/8"	5
E1-6A	3/8" x 1/8"	5
E1-6B	3/8" x 1/4"	10
E1-6C	3/8" x 3/8"	10
E1-6D	3/8" x 1/2"	5
E1-6E	3/8" x 3/4"	2
E1-8B	1/2" x 1/4"	5
E1-8C	1/2" x 3/8"	5
E1-8D	1/2" x 1/2"	10
E1-8E	1/2" x 3/4"	2
E1-10C	5/8" x 3/8"	2
E1-10D	5/8" x 1/2"	2
E1-10E	5/8" x 3/4"	2
E1-12D	3/4" x 1/2"	2
E1-12E	3/4" x 3/4"	2

Flare Ell



PART NO.	SIZE	PKG.
E2-2	1/8"	5
E2-3	3/16"	5
E2-4	1/4"	5
E2-5	5/16"	5
E2-6	3/8"	5
E2-8	1/2"	5
E2-10	5/8"	2
E2-12	3/4"	2

Reducing



PART NO.	SIZE	PKG.
ER2-64	3/8" x 1/4"	5
ER2-84	1/2" x 1/4"	2
ER2-86	1/2" x 3/8"	5
ER2-108	5/8" x 1/2"	2

Flare x Female Solder Ell



PART NO.	SIZE	PKG.
ES2-44	1/4" x 1/4"	5
ES2-66	3/8" x 3/8"	5
ES2-68	3/8" x 1/2"	2
ES2-88	1/2" x 1/2"	2

Flare x Female Pipe Ell



PART NO.	SIZE	PKG.
E3-4A	1/4" x 1/8"	5
E3-4B	1/4" x 1/4"	2
E3-5B	5/16" x 1/4"	2
E3-6A	3/8" x 1/8"	5
E3-6B	3/8" x 1/4"	2
E3-6C	3/8" x 3/8"	2
E3-6D	3/8" x 1/2"	2
E3-8C	1/2" x 3/8"	2
E3-8D	1/2" x 1/2"	2
E3-8E	1/2" x 3/4"	2
E3-10D	5/8" x 1/2"	2
E3-10E	5/8" x 3/4"	2

Female Flare X Flare Ell



PART NO.	SIZE	PKG.
E4-44	1/4" x 1/4"	5
E4-66	3/8" x 3/8"	2
E4-88	1/2" x 1/2"	2

INCLUDES COPPER GASKET.

Swivel Female Flare x Flare Ell



PART NO.	SIZE	PKG.
ES4-44	1/4" x 1/4"	2
ES4-66	3/8" x 3/8"	2
ES4-88	1/2" x 1/2"	2
ES4-1010	5/8" x 5/8"	2
ES4-1212	3/4" x 3/4"	2

Fusible Pipe Plug



PART NO.	SIZE	PKG.
168° F		
FP-A-168	1/8"	5
FP-B-168	1/4"	5
FP-C-168	3/8"	2
210° F		
FP-A-210	1/8"	5
FP-B-210	1/4"	5
FP-C-210	3/8"	2
283° F		
FP-A-283	1/8"	5
FP-B-283	1/4"	2
FP-C-283	3/8"	2

Refrigerant Drum Adapter



NPS CYLINDER X MALE FLARE. FURNISHED WITH FIBER GASKET.

PART NO.	SIZE	PKG.
K1-1	3/4" x 1/4"	10
K1-3	3/4" x 3/8"	2
K1-5	3/4" x 1/2"	2
K1-8	1/2" x 1/4"	2

BRASS FITTINGS

Fiber Drum Adapter Seal Gasket



PART NO.	SIZE	PKG.
K1-D	1/2"	10
K1-E	3/4"	10

Fusible Flare x Pipe Adapter



PART NO.	SIZE	PKG.
168° F		
FU-4B-168	1/4" x 1/4"	2
FU-4C-168	1/4" x 3/8"	2
FU-6C-168	3/8" x 3/8"	2
210° F		
FU-4B-210	1/4" x 1/4"	2
FU-4C-210	1/4" x 3/8"	2
FU-6C-210	3/8" x 3/8"	2
283° F		
FU-4B-283	1/4" x 1/4"	2
FU-4C-283	1/4" x 3/8"	2
FU-6C-283	3/8" x 3/8"	2

Long Forged Refrigeration Nut



INCREASE VIBRATION RESISTANCE.

PART NO.	SIZE	PKG.
N4-4	1/4"	10
N4-5	5/16"	5
N4-6	3/8"	10
N4-8	1/2"	5
N4-10	5/8"	5
N4-12	3/4"	2

Flare Cap



PART NO.	SIZE	PKG.
N5-3	3/16"	5
N5-4	1/4"	25
N5-5	5/16"	5
N5-6	3/8"	25
N5-8	1/2"	10
N5-10	5/8"	10
N5-12	3/4"	2

Finger Tight Flare Cap



NEOPRENE SEAL. SEE PAGE 45 FOR SINGLE INFORMATION.

PART NO.	SIZE	PKG.
NFT5-4-101	1/4"	1000
NFT5-6-101	3/8"	500

Short Forged Refrigeration Nut



PART NO.	SIZE	PKG.
NS4-3	3/16"	10
NS4-4	1/4"	25
NS4-4-CS	1/4"	1000
NS4-5	5/16"	10
NS4-6	3/8"	25
NS4-6-CS	3/8"	500
NS4-8	1/2"	25
NS4-8-CS	1/2"	350
NS4-10	5/8"	10
NS4-10-CS	5/8"	200
NS4-12	3/4"	5
NS4-12-CS	3/4"	100
NS4-14	7/8"	2

Reducing



PART NO.	SIZE	PKG.
NRS4-43	1/4" x 3/16"	5
NRS4-54	5/16" x 1/4"	5
NRS4-64	3/8" x 1/4"	10
NRS4-65	3/8" x 5/16"	10
NRS4-86	1/2" x 3/8"	10
NRS4-108	5/8" x 1/2"	5
NRS4-1210	3/4" x 5/8"	2

Old Style Extra Heavy Pre-1968 Nut



PART NO.	SIZE	PKG.
HNS4-4	1/4"(3/4" hex)	25
HNS4-6	3/8"(7/8" hex)	25
HNS4-8	1/2"(1" hex)	10
HNS4-10	5/8"(1 1/8" hex)	10
HNS4-12	3/4"(1 3/8" hex)	2

Frost-Proof Forged Refrigeration Nut

HOLES RELIEVE FROST IN THREAD AREA



PART NO.	SIZE	PKG.
NST4-4	1/4"	5
NST4-6	3/8"	5
NST4-8	1/2"	10
NST4-10	5/8"	2

Flare Plug



PART NO.	SIZE	PKG.
P2-3	3/16"	5
P2-4	1/4"	10
P2-5	5/16"	5
P2-6	3/8"	10
P2-8	1/2"	10
P2-10	5/8"	5
P2-12	3/4"	2

Flare x Flare X Male Pipe Tee



PART NO.	SIZE	PKG.
T1-4A	1/4" x 1/4" x 1/8"	10
T1-4B	1/4" x 1/4" x 1/4"	10
T1-4C	1/4" x 1/4" x 3/8"	2
T1-5B	5/16" x 5/16" x 1/4"	2
T1-6B	3/8" x 3/8" x 1/4"	5
T1-6C	3/8" x 3/8" x 3/8"	5
T1-6D	3/8" x 3/8" x 1/2"	2
T1-8B	1/2" x 1/2" x 1/4"	2
T1-8C	1/2" x 1/2" x 3/8"	2
T1-8D	1/2" x 1/2" x 1/2"	2
T1-10C	5/8" x 5/8" x 3/8"	2
T1-10D	5/8" x 5/8" x 1/2"	2

Flare Tee



PART NO.	SIZE	PKG.
T2-3	3/16"	5
T2-4	1/4"	10
T2-5	5/16"	5
T2-6	3/8"	10
T2-8	1/2"	5
T2-10	5/8"	2
T2-12	3/4"	2

BRASS FITTINGS

Reducing



PART NO.	SIZE	PKG.
TR2-446	1/4" x 1/4" x 3/8"	5
TR2-664	3/8" x 3/8" x 1/4"	5
TR2-668	3/8" x 3/8" x 1/2"	2
TR2-886	1/2" x 1/2" x 3/8"	2

Flare x Male Pipe Adapter



PART NO.	SIZE	PKG.
U1-2A	1/8" x 1/8"	5
U1-3A	3/16" x 1/8"	5
U1-3B	3/16" x 1/4"	5
U1-4A	1/4" x 1/8"	25
U1-4B	1/4" x 1/4"	25
U1-4C	1/4" x 3/8"	10
U1-4D	1/4" x 1/2"	10
U1-5A	5/16" x 1/8"	5
U1-5B	5/16" x 1/4"	5
U1-5C	5/16" x 3/8"	5
U1-6A	3/8" x 1/8"	10
U1-6B	3/8" x 1/4"	10
U1-6C	3/8" x 3/8"	10
U1-6D	3/8" x 1/2"	10
U1-6E	3/8" x 3/4"	5
U1-8A	1/2" x 1/8"	2
U1-8B	1/2" x 1/4"	5
U1-8C	1/2" x 3/8"	10
U1-8D	1/2" x 1/2"	10
U1-8E	1/2" x 3/4"	5
U1-10B	5/8" x 1/4"	5
U1-10C	5/8" x 3/8"	5
U1-10D	5/8" x 1/2"	10
U1-10E	5/8" x 3/4"	5
U1-12C	3/4" x 3/8"	2
U1-12D	3/4" x 1/2"	2
U1-12E	3/4" x 3/4"	2
U1-14E	7/8" x 3/4"	2

Reducing



PART NO.	SIZE	PKG.
UR2-43	1/4" x 3/16"	5
UR2-54	5/16" x 1/4"	5
UR2-64	3/8" x 1/4"	10
UR2-65	3/8" x 5/16"	5
UR2-84	1/2" x 1/4"	5
UR2-86	1/2" x 3/8"	10
UR2-106	5/8" x 3/8"	5
UR2-108	5/8" x 1/2"	5
UR2-128	3/4" x 1/2"	2
UR2-1210	3/4" x 5/8"	2

Female Flare x Flare Adapter



PART NO.	SIZE	PKG.
UR3-43	1/4" x 3/16"	2
UR3-46	1/4" x 3/8"	10
UR3-48	1/4" x 1/2"	5
UR3-64	3/8" x 1/4"	20
UR3-68	3/8" x 1/2"	10
UR3-84	1/2" x 1/4"	10
UR3-86	1/2" x 3/8"	10
UR3-810	1/2" x 5/8"	10
UR3-108	5/8" x 1/2"	5
UR3-1012	5/8" x 3/4"	2
UR3-1210	3/4" x 5/8"	2

Flare x Male Pipe x Flare Tee



PART NO.	SIZE	PKG.
T3-4A	1/4" x 1/8" x 1/4"	5
T3-4B	1/4" x 1/4" x 1/4"	5
T3-5B	5/16" x 1/4" x 5/16"	2
T3-6B	3/8" x 1/4" x 3/8"	5
T3-6C	3/8" x 3/8" x 3/8"	2
T3-6D	3/8" x 1/2" x 3/8"	2
T3-8C	1/2" x 3/8" x 1/2"	2
T3-8D	1/2" x 1/2" x 1/2"	2
T3-10D	5/8" x 1/2" x 5/8"	2

Flare Union



PART NO.	SIZE	PKG.
U2-2	1/8"	5
U2-3	3/16"	5
U2-4	1/4"	25
U2-5	5/16"	10
U2-6	3/8"	25
U2-8	1/2"	10
U2-10	5/8"	10
U2-12	3/4"	2
U2-14	7/8"	2

Flare x Flare X Female Flare Tee



PART NO.	SIZE	PKG.
T6-4	1/4"	2

Flare x Female Pipe Adapter



PART NO.	SIZE	PKG.
U3-2A	1/8" x 1/8"	5
U3-3A	3/16" x 1/8"	5
U3-4A	1/4" x 1/8"	10
U3-4B	1/4" x 1/4"	10
U3-4C	1/4" x 3/8"	5
U3-5A	5/16" x 1/8"	5
U3-5B	5/16" x 1/4"	5
U3-6A	3/8" x 1/8"	5
U3-6B	3/8" x 1/4"	5
U3-6C	3/8" x 3/8"	5
U3-6D	3/8" x 1/2"	5
U3-8B	1/2" x 1/4"	5
U3-8C	1/2" x 3/8"	5
U3-8D	1/2" x 1/2"	5
U3-8E	1/2" x 3/4"	2
U3-10C	5/8" x 3/8"	5
U3-10D	5/8" x 1/2"	5
U3-10E	5/8" x 3/4"	2

Flare x Solder Adapter

FURNISHED WITH
COPPER GASKET.



PART NO.	SIZE	PKG.
US3-44	1/4" x 1/4"	10
US3-45	1/4" x 5/16"	5
US3-46	1/4" x 3/8"	5
US3-64	3/8" x 1/4"	5
US3-65	3/8" x 5/16"	5
US3-66	3/8" x 3/8"	10
US3-68	3/8" x 1/2"	5
US3-610	3/8" x 5/8"	5
US3-86	1/2" x 3/8"	2
US3-88	1/2" x 1/2"	5
US3-810	1/2" x 5/8"	2
US3-108	5/8" x 1/2"	2
US3-1010	5/8" x 5/8"	5
US3-1012	5/8" x 3/4"	2
US3-1014	5/8" x 7/8"	2
US3-1212	3/4" x 3/4"	5
US3-1214	3/4" x 7/8"	2

BRASS FITTINGS

Female Flare X Female Flare Connector

INCLUDES TWO COPPER GASKETS.



PART NO.	SIZE	PKG.
U4-4	1/4"	10
U4-6	3/8"	10
U4-8	1/2"	2
U4-10	5/8"	2
U4-12	3/4"	2

Swivel Female Flare x Solder Adapter

A32700 SERIES PG 48.



PART NO.	SIZE	PKG.
US5-44	1/4" x 1/4"	5
US5-66	3/8" x 3/8"	5
US5-88	1/2" x 1/2"	5
US5-1010	5/8" x 5/8"	5
US5-1212	3/4" x 3/4"	2

BRASS PIPE FITTINGS

JB's American made forged brass pipe fittings are manufactured from CA 377 alloy and are threaded to Dryseal Taper Pipe Standards to generally comply with SAE, ASA, ASME, and MS Standards. Forgings can be used on vacuums to pressures of 5,000 psi depending on size, material, and conditions.

FEATURES:

- Good vibration resistance (improved by using long nuts)
- Low cost
- Easy assembly
- American made quality
- Wide selection

JB recommends the use of a compatible thread sealant and tightening 2 1/2 full turns past hand tight.

Vacuum and pressures of 5,000 psi can be handled depending upon the size, material, and conditions.

Caution: Over-tightening and dirt can damage fittings.

JB brass fittings are sold in box quantities only. For more information, please contact sales@jbind.com or 800.323.0811.

Swivel Female Flare Connector



PART NO.	SIZE	PKG.
US4-4	1/4"	10
US4-5	5/16"	5
US4-6	3/8"	10
US4-8	1/2"	10
US4-10	5/8"	5

Female Flare X Female Pipe Adapter

INCLUDES COPPER SEAL GASKET.



PART NO.	SIZE	PKG.
U6-4A	1/4" x 1/8"	2
U6-4B	1/4" x 1/4"	2

Female Flare x Male Pipe Adapter

INCLUDES COPPER SEAL GASKET.



PART NO.	SIZE	PKG.
U5-4A	1/4" x 1/8"	5
U5-4B	1/4" x 1/4"	10
U5-6B	3/8" x 1/4"	5
U5-8C	1/2" x 3/8"	2
U5-8D	1/2" x 1/2"	2

Extra Long Flare x Male Pipe Adapter

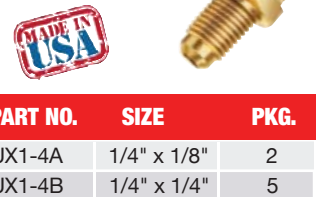

PART NO.	SIZE	PKG.
UX1-4A	1/4" x 1/8"	2
UX1-4B	1/4" x 1/4"	5



PART NO.	SIZE	PKG.
101-A	1/8"	5
101-B	1/4"	10
101-C	3/8"	5
101-D	1/2"	2
101-E	3/4"	2

Extra Long Flare Union



PART NO.	SIZE	PKG.
UX2-4	1/4"	5

NOMINAL PIPE SIZE THREADS

NOM. PIPE THD./ IN.	NOM. PIPE THD./ IN.	NOM. PIPE THD./ IN.	NOM. PIPE THD./ IN.
1/16"	27	2"	11.5
1/8"	27	2-1/2"	8
1/4"	18	3"	8
3/8"	18	3-1/2"	8
1/2"	14	4"	8
3/4"	14	5"	8
1"	11.5	6"	8
1-1/4"	11.5	8"	8
1-1/2"	11.5		

ELL



PART NO.	SIZE	PKG.
100-A	1/8"	5
100-B	1/4"	5
100-C	3/8"	5
100-D	1/2"	2
100-E	3/4"	2

Coupling (PC)



PART NO.	SIZE	PKG.
103-A	1/8"	5
103-B	1/4"	10
103-C	3/8"	5
103-D	1/2"	5
103-E	3/4"	5

BRASS FITTINGS

Hex Brushing (R1)



PART NO.	SIZE	PKG.
110-BA	1/4" x 1/8"	10
110-CA	3/8" x 1/8"	5
110-CB	3/8" x 1/4"	10
110-DA	1/2" x 1/8"	5
110-DB	1/2" x 1/4"	10
110-DC	1/2" x 3/8"	10
110-EA	3/4" x 1/8"	2
110-EB	3/4" x 1/4"	5
110-EC	3/4" x 3/8"	5
110-ED	3/4" x 1/2"	5
110-FD	1" x 1/2"	2
110-FE	1" x 3/4"	2

Long Nipple



PART NO.	SIZE	PKG.
113-A15	1/8" x 1-1/2"	5
113-A2	1/8" x 2"	5
113-A25	1/8" x 2-1/2"	5
113-A3	1/8" x 3"	5
113-A35	1/8" x 3-1/2"	5
113-B15	1/4" x 1-1/2"	5
113-B2	1/4" x 2"	5
113-B25	1/4" x 2-1/2"	5
113-B3	1/4" x 3"	5
113-B35	1/4" x 3-1/2"	5
113-C15	3/8" x 1-1/2"	5
113-C2	3/8" x 2"	5
113-C25	3/8" x 2-1/2"	5
113-C3	3/8" x 3"	5
113-C35	3/8" x 3-1/2"	5
113-D15	1/2" x 1-1/2"	5
113-D2	1/2" x 2"	5
113-D25	1/2" x 2-1/2"	5
113-D3	1/2" x 3"	2
113-D35	1/2" x 3-1/2"	2

Street El



PART NO.	SIZE	PKG.
116-A	1/8" forged	5
116-B	1/4" closed forged	5
116-C	3/8" closed forged	5
116-D	1/2" forged	2

Hex Nipple (U10)



PART NO.	SIZE	PKG.
122-A	1/8"	5
122-B	1/4"	10
122-C	3/8"	5
122-D	1/2"	5
122-E	3/4"	5

CLOSE Nipple



PART NO.	SIZE	PKG.
112-A	1/8"	5
112-B	1/4"	10
112-C	3/8"	5
112-D	1/2"	5
112-E	3/4"	5

Hex Head Plug (P3)



PART NO.	SIZE	PKG.
121-A	1/8"	10
121-B	1/4"	10
121-C	3/8"	5
121-D	1/2"	5
121-E	3/4"	5
121-F	1"	2

Compression Break-Off Sleeve (Pilot) Nut



PART NO.	SIZE	PKG.
81LB-4	1/4"	10

LIMITED WARRANTY

The entire limited warranty and OTC warranty can be found at www.jbind.com. Products sold by JB Industries, Inc. are warranted for a period of 12 months from the date of sale with the following exceptions:

- Vacuum pumps are warranted 24 months LIMITED over-the-counter. Not changing the oil will void the over the counter warranty.
- Digital gauges are warranted 12 months ATLAS scale 24 months.
- ROTHENBERGER tools are warranted 24 months.

JB limits this warranty to the repair, replacement or credit at invoice price (JB's option) of products that in JB's opinion are defective due to defects in workmanship and/or materials. Warranty claims resulting from obvious product abuse, misuse such as broken parts or lack of maintenance including failure to keep the vacuum pump filled with clean oil, abnormal use or normal wear and tear will not be honored as warranty repair and will be subject to JB's published repair costs. This express warranty is in lieu of and excludes all other warranties, guarantees and/or representations, express or implied, of JB and/or the manufacturer of such products that make NO WARRANTY OF MERCHANTABILITY OR FITNESS FOR ANY PARTICULAR PURPOSE. Technical information, recommendations and advice as to properties and usages of materials, design, installation and use of products, engineering and other matters are provided as an accommodation and are intended only as suggestions. Although they are believed to be accurate, based on JB's knowledge and experience, JB assumes no obligation or liability for any results obtained in their use or application, and they are not to be construed as establishing any warranty, express or implied. In no event shall JB be liable for claims for any damages whatsoever (whether direct, foreseeable, consequential or special) suffered by buyer or anyone else arising out of any breach by JB. JB makes no warranty to those defined as consumers in the Magnuson-Moss Warranty-Federal Trade Commission Improvement Act.

Disclaimers: All product items pictured, described, or otherwise displayed herein are subject to changes, alterations, and/or modifications at anytime by JB Industries, Inc. The terms and conditions for the purchase of JB Industries, Inc. products are subject to changes, alterations, and/or modifications at any time by JB Industries, Inc. and will be made available upon request to JB Industries and shall be provided to customers of JB Industries, Inc. at time of purchase.

WARRANTY

JB INDUSTRIES OTC WARRANTY PROGRAM NOT CHANGING OIL WILL VOID WARRANTY

VACUUM PUMPS: 24 MONTHS

***ALL WARRANTY STATEMENTS APPLY TO BOTH, PLATINUM AND ELIMINATOR PUMPS.**

Pumps that are in warranty are examined as soon as they arrive at the warehouse so that we may contact the wholesaler regarding our determination. The over-the-counter warranty applies only to the manufacturing defects and is VOID if the problem has been determined to be abuse.

CHECK FOR SIGNS OF ABUSE:

- A. Bell back housing area
- B. Base is broken or missing corners
- C. Side of trap
- D. Damage to protective fins and drain valve
- E. Sight Glass shows buildup
- F. Flat hit marks on top and bottom of corners
- G. Handle bent down or broken
- H. Intake damaged or missing

THE WARRANTY IS VOID IF...

- 1. Oil has not been used in pump or changed
- 2. Corrosive substances have been introduced in the pump
- 3. The pump has been altered or any components removed or missing

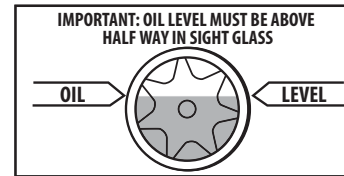
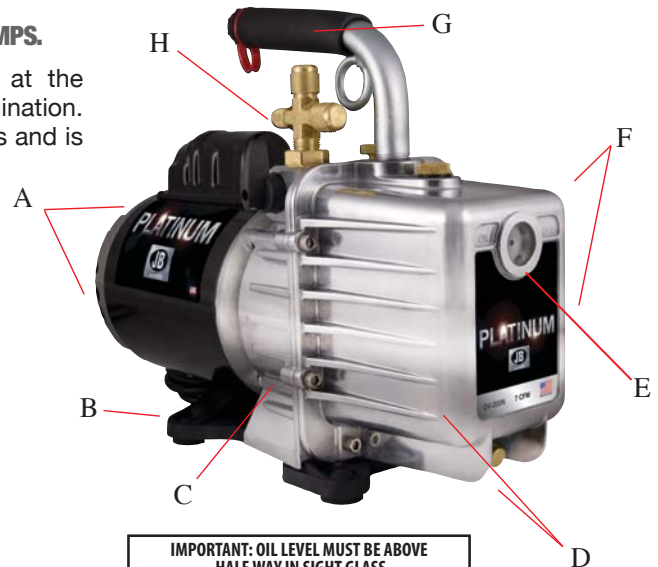

MANIFOLDS: LIFETIME BAR ONLY

Manifolds carry a lifetime warranty on the bar only and does not include coverage of any parts. The 12 month over-the-counter warranty covers manufacturing defects only, not abuse. Signs of abuse include lens cracked or missing, gauges that can be loosened by hand, and drop marks on manifolds or unions. Check calibration with the set screw on the gauge as well.

DIGITAL INSTRUMENTS (GAUGES, MANIFOLDS): 12 MONTHS, ATLAS SCALE: 24 MONTHS

Check the batteries. The product will provide a low battery warning with flashing dots at the bottom of the display. Plug in and toggle through the settings as well as the temperature setting to check if the sensors are working. If the sensors are working, push the on/off button to auto cal to see if it will return to zero. If any of the readings are off, check to see what the temperature sensor is for both sensors. A few degrees difference between the two can cause a problem with the readings. Check for signs of abuse which include a cracked case, drop marks on fittings, display is dimmed or damaged, sensor is pinched or sliced, and the hook is bent or missing.

DIGITAL MICRON GAUGES: 12 MONTHS

For the DV-22N, check the last recorded vacuum and then press twice to clear the last recorded vacuum to see if it resets (if the numbers are jumping around, it may be a cold pump or oil contaminant inside the thermistor). If the numbers are jumping around after you have disconnected the gauge from the vacuum and it will not return to one, wait until the gauge auto calibrates. Unit will display JB and turn off before it reads 1 if batteries are low. JB vacuum gauges utilize a thermistor, which if contaminated, can result in faulty readings. Make sure that the sensors are cleaned with rubbing alcohol (Isopropyl) if readings seem erratic or as part of a regular maintenance regiment. DV-22N will display a "1" if vacuum reading is above 9,000 microns. The DV-40/DV-41 will display "00000000" when the vacuum level is above 12,000 microns. Check for signs of abuse which include a cracked case, the coupler is loose at the base of the case, the O-ring/gasket is chewed up or damaged or missing, there are pliers or channel locks on couplers, and the hook is broken or missing.

ROTHENBERGER TOOLS: 24 MONTHS

Check for signs of abuse.

WARRANTY

HOW TO RETURN PRODUCT

Prior to returning any product to JB, you are required to obtain a Return Goods Authorization number (RGA). Contact customer service at 800-323-0811 to obtain your RGA. Insure that all returned products are packed adequately to avoid damage during shipment as we will not honor warranty claims for items damaged in transit. The recommended packing procedure for pumps is detailed below. Paperwork should be placed in a separate plastic bag and should include your assigned RGA, a description of the problem, a copy of the invoice, and any customer assigned repair or purchase order number (if applicable). Please provide contact information of whom to inform of package receipt as well as the person authorized to accept repair charges should the warranty be void.

PLEASE MAKE SURE THAT ALL ITEMS ARE PACKAGED CORRECTLY TO PREVENT DAMAGE IN SHIPMENT.

WE WILL NOT HONOR WARRANTY CLAIMS FOR ITEMS DAMAGED IN TRANSIT.

DO NOT PUT STICKERS OR STRONG TAPE ON FACES OF PRODUCTS AS ITEM MAY COME BACK WITH NO MANUFACTURER DEFECTS.

The recommended packing procedure for vacuum pumps is outlined below.

RETURNING VACUUM PUMP FOR REPAIR

Before returning pump to factory, follow these steps to ensure that no additional charges are incurred because of poor packaging.

1. Completely drain oil from pump and close off all valves. If red cap is on pump put in end of handle to prevent leakage during transit.
2. Place pump in plastic bag and seal.
3. Cushion bottom of carton with packing paper or crumpled newspaper before putting pump in carton. Use packing paper or crumpled newspaper around all sides and the top.

DO NOT USE PEANUTS.

4. Place all paperwork in a separate plastic bag and seal. Please include RGA number issued by JB and a detailed description of the problem.
5. If an estimate is required prior to repair, be certain this is clearly specified and highlighted.
6. Depending on the time of year, allow 2-4 weeks for repair service.

SHIP INFO

JB Industries
Repair Department
601 N. Farnsworth Ave.
Aurora, IL 60505

FOR VACUUM PUMP REPAIRS ONLY:

Customers in Alaska, Arizona, California, Idaho, Montana, Nevada, Oregon, Utah, and Washington have the option of sending their vacuum pump repairs to JB or to Merced Wholesale:

Merced AC Equipment Service
805 S. Fremont
Alhambra, CA 91803
Phone: 626-293-5710
Fax: 626-289-1961

POP MARKETING AND MERCHANDISING

MADE IN CHI-NOT T-SHIRTS

MKDS58 SHORT SLEEVE TEE SHIRT

Stock Size XL



\$13.50

KOBRA® BOTTLE OPENER

MKDS56



\$7.50

MADE IN CHI-NOT T-SHIRTS

MKDS59 LONG SLEEVE TEE SHIRT

Stock Size XL (Not shown)

\$18.50



JB PLAYING CARDS

MKDS63



\$7.50

JB INDUSTRIES BALL CAP

MKDS51 BLACK HAT

MKDS52 WHITE HAT

MKDS BLACK+WHITE HAT

\$14.50



JB INC CAN COOZIES

MKDS55

\$4.00



POSTERS

SAMPLING PLEASE REFER TO WEBSITE FOR ALL AVAILABLE POSTERS



POP MARKETING AND MERCHANDISING

JB has point of purchase material to highlight your show-room. From banners, to backing for pegboard and slatwall, to counter mats and headers, please refer to www.jbind.com/marketing for an order form or call **800-323-0811** to place your order.



MKDS22
BANNER 36" X 48" WITH
GROMMETS.



MKDS24
BANNER 36" x 48" WITH
GROMMETS.



MKDS04
BACKING FOR PEGBOARD 2 PANELS
34.5" X 23.5" EACH.



MKDS03 Flat header
12" X 36".

MKDS02 Header for end caps
12" X 36" with a 2" bend to attach to gondolas.

MKDS05
BACKING FOR SLATWALL 2 PANELS
36" X 47.5" EACH.

**WANT TO STAY UP-TO-DATE ON EVERYTHING JB INDUSTRIES?
MAKE SURE YOU ARE CONNECTED WITH US TO BE THE FIRST TO KNOW
ABOUT NEW PRODUCTS, TRAINING VIDEOS, EXPERT TIPS AND MORE.
WE'RE ONLY A CLICK AWAY.**

Follow us on Twitter @JBIND

Like us on Facebook

Follow our Company page on LinkedIn

Subscribe to our Youtube Channel JBJustBetter



You Tube

VACUUM PUMP REPAIR

DV-42N THROUGH DV-285N SERIES

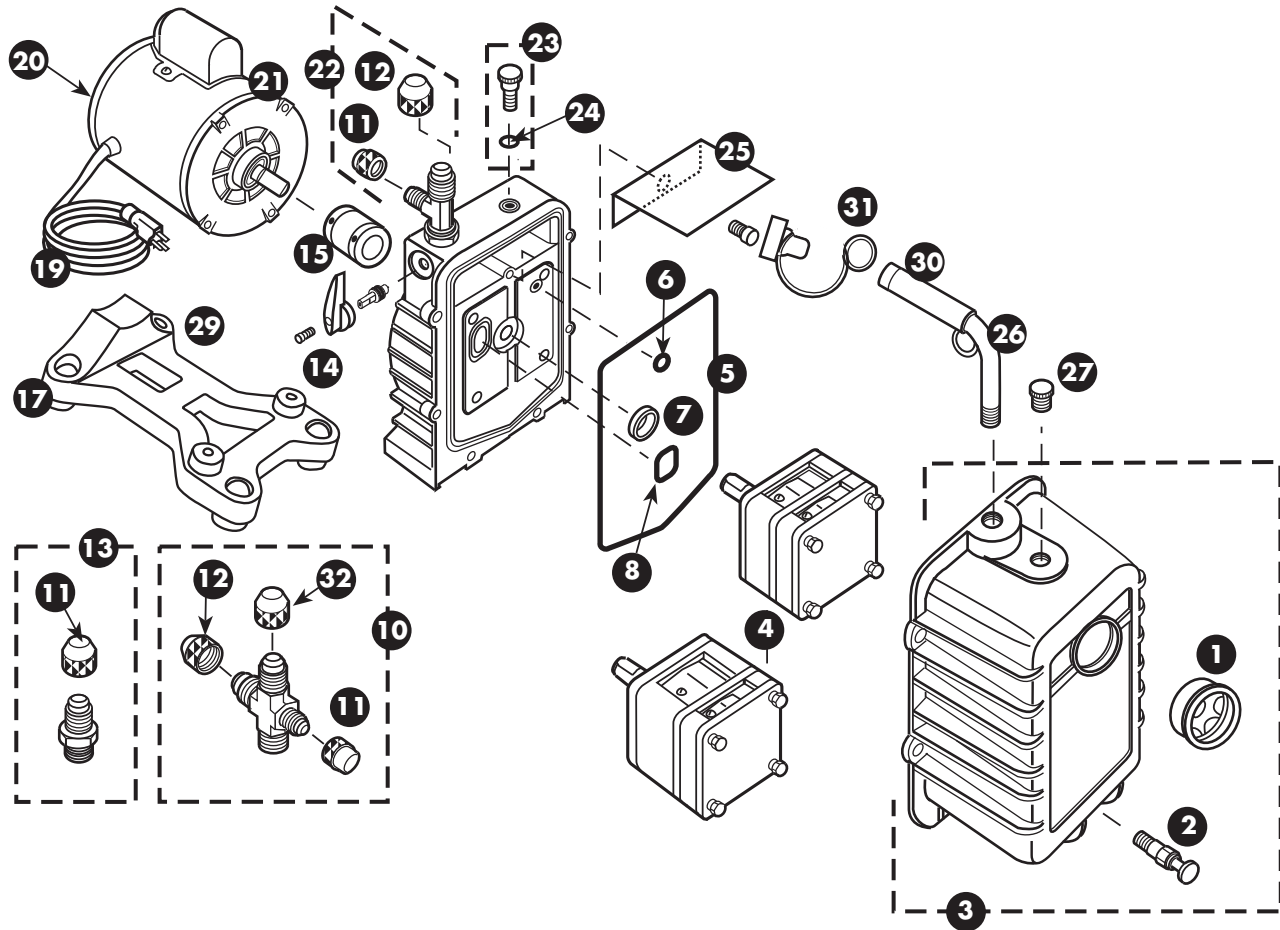

WHEN ORDERING, PLEASE PROVIDE THE FOLLOWING INFORMATION:

- MODEL NUMBER
- FOUR DIGIT SERIAL NUMBER
- PART NUMBER AND DESCRIPTION

FOR REPAIR PARTS FOR DV-42 AND DV-42N SERIES PUMPS
MANUFACTURED PRIOR TO JANUARY 2001 SEE PAGE 70.

OPERATING INSTRUCTIONS FOR ALL PUMPS MANUFACTURED SINCE
1980 AVAILABLE UNDER "TECHNICAL INFORMATION"
AT WWW.JBIND.COM.

NEW:

NOTE : ON FLEXIBLE COUPLER (15)
FLEBIBLE SECTION IS AVAILABLE AS
PR-308

NEW:

PR-209 NOW INCLUDES STEM WITH
O-RINGS AND RETAINER

NEW:

PR-56 - ADAPTOR NUT WITH O-RING

VACUUM PUMP REPAIR

REFERENCE	PART NO.	DESCRIPTION	REFERENCE	PART NO.	DESCRIPTION
1	PR-1	Sight Glass	15	PR-208	Flexible Coupler
2	PR-2	Drain Valve	15	PR-308	Flexible Section Only
3	PR-300	DV-42N Through DV200N Cover Assy. w/ Sight Glass And Drain Valve	16	PR-42	Motor Foot With Screw
3	PR-301	DV-285N Cover Assy. w/ Sight Glass And Drain Valve	17	PR-59	Base Foot
3	<u>PR-200</u>	No Longer Available. Can Substitute PR-201	19	PR-31	Line Cord (Emerson Motor)
3	<u>PR-201</u>	DV-142N & DV-200N Cover Assy. w/ Sight Glass, Drain Valve & Guard	19	PR-58	Line Cord (Marathon Motor)
4	<u>PR-202</u> OBSOLETE	DV-85N Cartridge w/ O-rings And Seal	20	PR-35	Rocker Switch With Prongs (Marathon 1101-0105)
4	<u>PR-203</u> OBSOLETE	DV-142N Cartridge w/ O-rings And Cover Seal	20	PR-54	Rocker Switch With Wire Leads (Emerson)
4	<u>PR-204</u> OBSOLETE	DV-200N Cartridge w/ O-rings And Cover Seal	21	PR-206	1/2 Hp, 115v, 60 Hz Motor With Line Cord And Switch
4	<u>PR-214</u> OBSOLETE	DV-285N Cartridge w/ O-rings And Cover Seal	21	PR-207	1/2 Hp, 115/230v, 50/60 Hz Motor w/ Line Cord And Switch
4	PR-302	DV-85N Cartridge w/ O-rings And Cover Seal	22	PR-5	Intake Tee With Caps
4	PR-303	DV-142N Cartridge w/ O-rings And Cover Seal	23	PR-7	Gas Ballast Valve With O-ring
4	PR-304	DV-200N Cartridge w/ O-rings And Cover Seal	24	P90009	O-ring, Gas Ballast Valve
4	PR-314	DV-285N Cartridge w/ O-rings And Cover Seal	25	PR-40	Splash Guard And Screw (Excludes 3cfm Manufactured Before 1/01. Use PR-39.)
5	<u>PR-217</u>	Cover Seal	26	PR-75	Cushioned Handle With Lift Ring 1/2" NPT And DV-EP-8 As Of 2008
5	PR-311	Cover Seal	26	PR-205	Cushioned Handle 3/8" NPT
6	PR-211	Trap O-ring, Gas Ballast	27	PR-22	Oil Fill Plug with O-ring
7	PR-3	Shaft Seal	28	PR-56	Adapter Nut With O-ring
8	<u>PR-215</u>	Trap O-ring, Intake	29	PR-62	Pump Base (Includes Feet)
8	PR-315	Trap O-ring, Intake	30	PR-500	Cushion And Cap 3/8" NPT
9	PR-4	Rubber Foot & Screw Assembly (1 Per Package)	30	PR-501	Cushion And Cap 1/2" NPT
10	PR-76	Intake Caps With Cross	31	DV-EP6	Tethered Safety Cap 3/8"
11	NFT5-4	1/4" O-ring, Intake	31	DV-EP8	Tethered Safety Cap 1/2"
12	NFT5-6	3/8" O-ring Cap	32	NFT5-8	1/2 Cap With O-ring
12A	NFT5-8	1/2" O-ring Cap	Not Shown	PR-18	Cartridge Valve Repair Kit (Includes DV-285N As Of 2007 Models)
13	PR-32	1/4" Intake With Cap	Not Shown	PR-52	DV-285N Cartridge Valve Repair Kit Prior To 2007 Models
14	PR-209	Plastic Isolation Valve Handle And Screw w/ Stem and Retainer (Not Interchangeable w/ PR- 210)	Not Shown	PR-45	Pump Repair Kit: PR-1, PR-2, PR-4(2), PR-42, PR-208
14	<u>PR-210</u>	Metal Isolation Valve Handle And Screw			

Plain type: All pumps

Bold type: pumps manufactured beginning January 2001

Underlined: Pumps manufactured before January 2001

PR-62 will fit all pumps with serial #0101 and higher

VACUUM PUMP REPAIR PARTS

DV-3E, DV-4E AND DV-6E ELIMINATOR® SERIES

OPERATING INSTRUCTIONS FOR ALL PUMPS MANUFACTURED SINCE 1980
AVAILABLE UNDER "TECHNICAL INFORMATION"
AT WWW.JBIND.COM

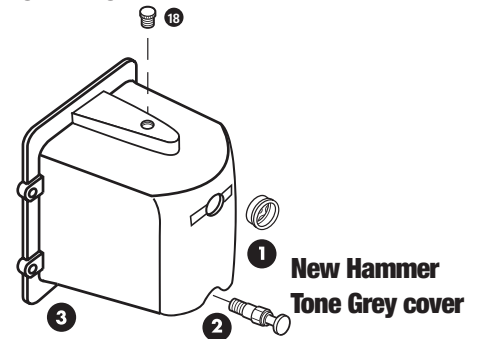
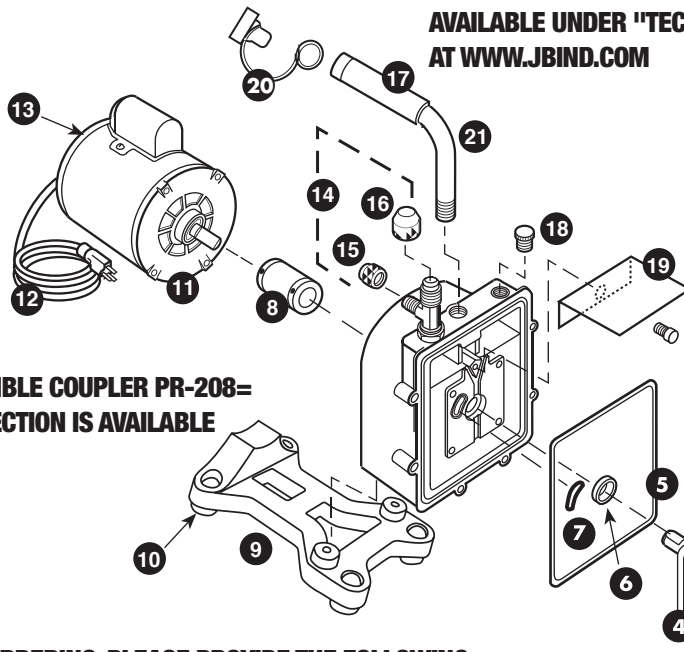

NEW:

NOTE : FLEXIBLE COUPLER PR-208=
FLEXIBLE SECTION IS AVAILABLE
AS PR-308

New Hammer
Tone Grey cover

Note:
Black covered
covers are no
longer available.
New Hammer
Tone Grey will
fit.

WHEN ORDERING, PLEASE PROVIDE THE FOLLOWING INFORMATION:

- MODEL NUMBER
- FOUR DIGIT SERIAL NUMBER
- PART NUMBER AND DESCRIPTION

REFERENCE	PART NO.	DESCRIPTION
1	PR-1	Sight Glass
2	PR-2	Drain Valve
3	PR-10	Dv-3E, Dv-4E And Dv-6E Cover Assembly Includes Sight Glass, Drain Valve, Oil Fill Plug
4 New	PR-403	Dv-3E Cartridge Complete With O-Rings And Cover Seal
4 New	PR-404	Dv-4E Cartridge Complete With O-Rings And Cover Seal
4 New	PR-406	Dv-6E Cartridge Complete With O-Rings And Cover Seal
5 New	PR-217	Cover Seal
6	PR-3	Shaft Seal
7	PR-315	Trap Intake O-Ring
8	PR-208	Flexible Coupler
9	PR-62	Pump Base (Includes Rubber Feet)
10	PR-59	Rubber Foot
Not Shown	PR-18	Cartridge Valve Repair Kit
11	PR-207	1/2 Hp, 115/230 V, 50/60 Hz Motor With Line Cord And Switch

REFERENCE	PART NO.	DESCRIPTION
11	PR-206	1/2 Hp Motor With Line Cord And Switch
12	PR-31	Line Cord (Emerson Motor)
12 New	PR-58	Line Cord (Marathon Motor)
13	PR-54	Motor Switch, Rocker
14	PR-63	Intake Tee With Cap
15	NFT5-4	1/4" O-Ring Cap
16	NFT5-6	3/8" O-Ring Cap
17 Black	PR-500	Cushion And Cap For 3/8" Npt
17 Hammertone	PR-501	Cushion And Cap For 1/2" Npt
18	PR-22	Oil Fill Plug With O-Ring
19	PR-39	Dv-3E Splash Guard With Screw
19	PR-40	Dv-4E And Dv6e Splash Guard With Screw
20 Black	DV-Ep6	Tethered Safety Plug 3/8"
20 Hammertone	DV-Ep8	Tethered Safety Plug 1/2"
21 Black	PR-205	Cushioned Handle 3/8" Npt
21 Hammertone	PR-65	Cushioned Handle 1/2" Npt

MANIFOLD REPAIR PARTS

ZEPPELIN BRASS SERIES MANIFOLD

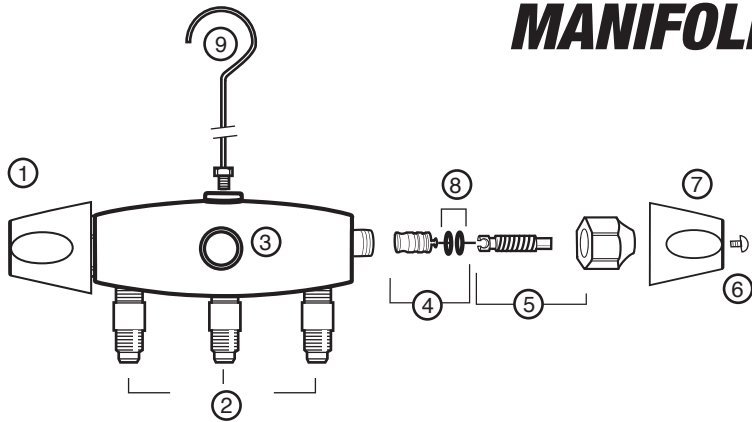

REFERENCE	PART NO.	DESCRIPTION
1	MR-601	Hand Wheel And Screw
2	U1-4A	1/4" Intake
3	MR-525	Sight Glass
4	MR-505	Piston With Seat And O-Rings
5	MR-516	Stem And Nut
6	MR-601	Hand Wheel And Screw
7	MR-503	Hand Wheel Screws (Two)
8	MR-509	O-Rings (Two)
9	M2-102N	Hanging Hook

SEE PAGE 37 FOR MANIFOLD REBUILD KITS

ZEPPELIN ALUMINUM SERIES MANIFOLD

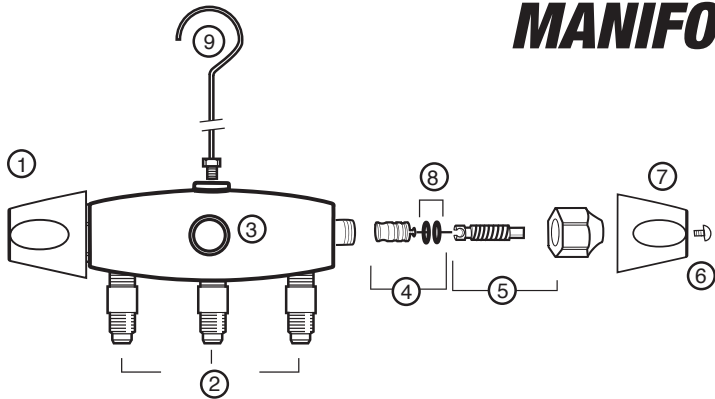

REFERENCE	PART NO.	DESCRIPTION
1	MR-601	Hand Wheel And Screw
2	U1-4A	1/4" Intake
3	MR-525	Sight Glass
4	MR-505	Piston With Seat And O-Rings
5	MR-516	Stem And Nut
6	MR-601	Hand Wheel And Screw
7	MR-503	Hand Wheel Screws (Two)
8	MR-509	O-Rings (Two)
9	M2-102N	Hanging Hook

SEE PAGE 37 FOR MANIFOLD REBUILD KITS

ZEPPELIN 4-VALVE ALUMINUM SERIES MANIFOLD

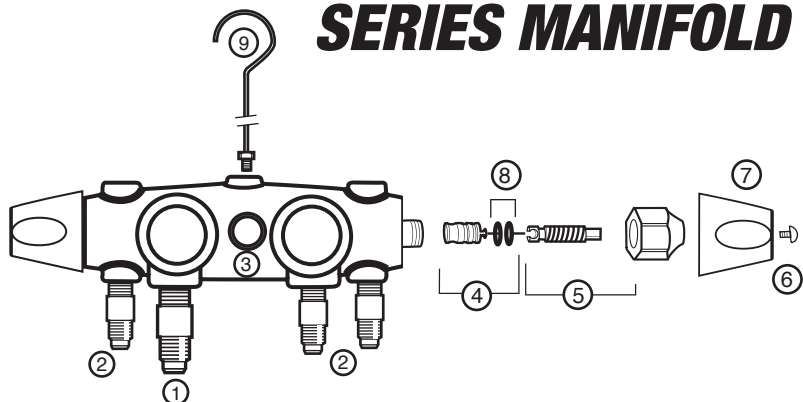

REFERENCE	PART NO.	DESCRIPTION
1	U1-6B	3/8" Intake
2	U1-4A	1/4" Intake
3	MR-525	Sight Glass
4	MR-605	Piston With Seat And O-Rings
5	MR-607	Stem And Nut
6	MR-601	Hand Wheel And Screw
7	MR-503	Hand Wheel Screws (Two)
8	MR-409	O-Rings (Two)
9	M2-102N	Hanging Hook

MANIFOLD REPAIR PARTS

M2 SERIES MANIFOLD

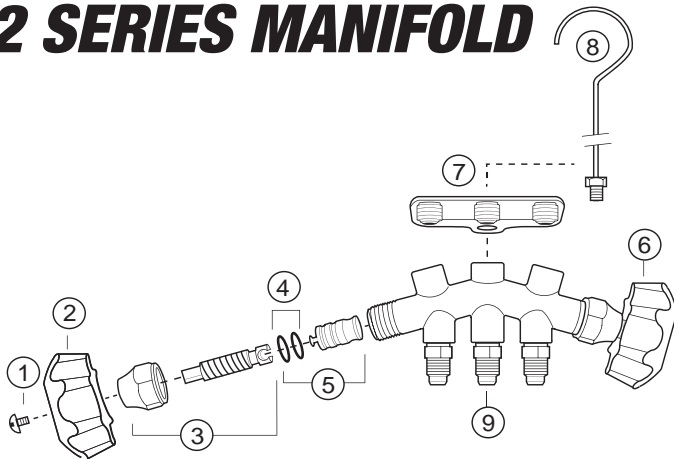

REFERENCE	PART NO.	DESCRIPTION
1	MR-503	Hand Wheel Screw (Two)
2	MR-501B	Blue Hand Wheel And Screw
3	MR-516	Stem And Nut
4	MR-509	O-Ring (Two)
5	MR-505	Piston With Seat And O-Rings
6	MR-501R	Red Hand Wheel
7	M2-300	Hose Holder
8	M2-102N	Hanging Hook
9	U1-4A	Intake

SEE PAGE 37 FOR MANIFOLD REBUILD KITS FOR M2 ONLY

M5 THROUGH M9 SERIES MANIFOLD

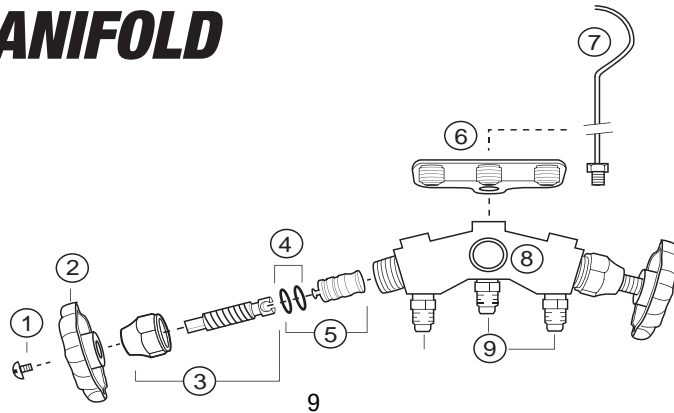

REFERENCE	PART NO.	DESCRIPTION
1	MR-503	Hand Wheel Screw (Two)
2	MR-508	Metal Hand Wheel And Screw
3	MR-516	Stem And Nut
4	MR-509	O-Ring (Two)
5	MR-505	Piston With Seat And O-Rings
6	M2-300	Hose Holder
6	MR-521	Acme Thread Hose Holder
7	M2-102N	Hanging Hook
8	MR-520	Sight Glass
9	U1-4A	Intake
9	AR-13450	Acme Intake

M3 SERIES MANIFOLD

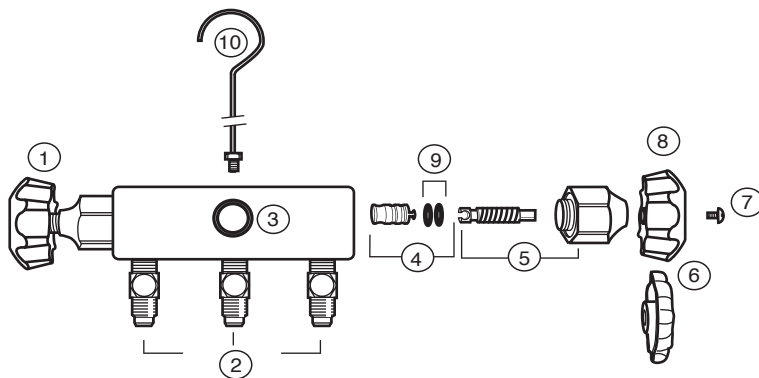

REFERENCE	PART NO.	DESCRIPTION
1	MR-501B	Blue Hand Wheel And Screws
2	MR-550	1/4" Intake And Hose Holder
3	MR-520	Sight Glass
4	MR-505	Piston With Seat And O-Rings
5	MR-560	Stem And Nut
6	MR-508	Metal Hand Wheel And Screw
7	MR-503	Hand Wheel Screws (Two)
8	MR-501R	Red Hand Wheel
9	MR-509	O-Rings (Two)
10	M2-102N	Hanging Hook

MANIFOLD REPAIR PARTS

M4 SERIES MANIFOLD

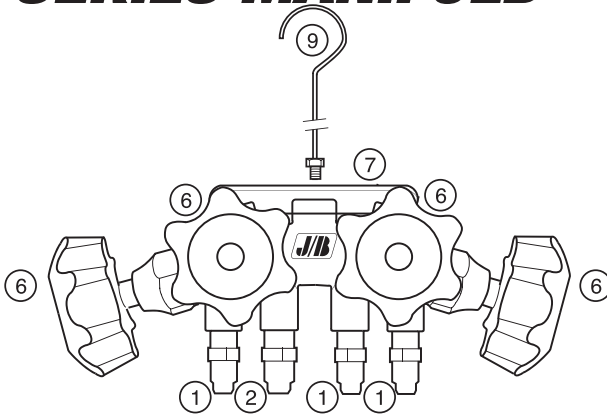

REFERENCE	PART NO.	DESCRIPTION
1	U1-4A	1/4" Intake
2	U1-6A	3/8" Intake
3	MR-505	Piston With Seat And O-Rings
4	MR-516	Stem And Nut
5	MR-503	Handwheel Screws
6	MR-501B	Blue Hand Wheel And Screw
	MR-501Y	Yellow Handwheel And Screw
	MR-504B	Black Handwheel And Screw
	MR-501R	Red Handwheel And Screw
7	MR-531	Hose Holder
8	MR-509	O-Ring (2)
9	M2-102N	Hanging Hook

SEE PAGE 37 FOR MANIFOLD REBUILD KITS FOR M4 ONLY

4 VALVE BALL VALVE MANIFOLD

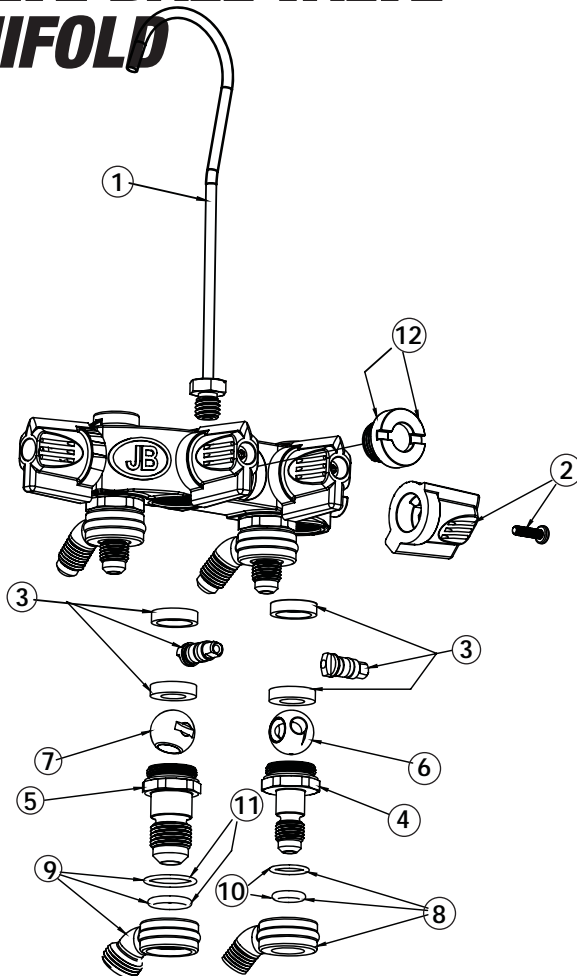

REFERENCE	PART NO.	DESCRIPTION
26Xxx Series	Ball Valve Manifold Repair Parts	
1	M2-102N	Hanging Hook
2	MR-502	Handle & Screw
3	MR-Bvk	Ball Valve Kit Including
	(2) Seals	
	(1) Stem	
	(2) O-Rings	
	(1) Washer	
4	MR-444	1/4" Retainer Fitting
5	MR-446	3/8" Retainer Fitting
6	MR-611	Throttle Ball
7	MR-610	Ball
8	MR-544	1/4" Hose Holder Sleeve With O-Ring
9	MR-546	3/8" Hose Holder Sleeve With O-Ring
10	MR-504	1/4" Hose Holder Sleeve O-Ring
11	MR-506	3/8" Hose Holder Sleeve O-Ring
12	MR-525	Sightglass With O-Ring

PRODUCT INDEX

PART #	PG.	PART #	PG.	PART #	PG.	PART #	PG.	PART #	PG.	PART #	PG.
100-A	70	11509	65	24025	23	25425	27	28105	30	28882	31
100-B	70	11511	65	24033	23	25500	27	28170	30	28884	31
100-C	70	11575	65	24040	23	25508	27	28172	30	28886	31
100-D	70	13493	50	24044	23	25523	27	28174	30	28888	31
100-E	70	13494	50	24050	23	25525	27	28176	30	28932	31
101-A	70	2VZR-P	37	24058	23	25533	27	28180	30	28935	31
101-B	70	2VZR-S	37	24065	23	25548	27	28182	30	28952	31
101-C	70	23000	21	24069	23	25550	27	28184	30	28954	31
101-D	70	23004	21	24100	23	25558	27	28186	30	28959	31
101-E	70	23006	21	24108	23	25573	27	28188	30	28970	31
103-A	70	23013	21	24125	23	25708	27	28192	30	28972	31
103-B	70	23017	21	24133	23	25713	27	28196	30	28974	31
103-C	70	23025	21	24140	23	26000	24, 25	28197	30	28976	31
103-D	70	23029	21	24144	23	26008	25	28199	30	28980	31
103-E	70	23031	21	24150	23	26025	25	28202	30	28982	31
110-BA	71	23033	21	24158	23	26033	25	28205	30	28984	31
110-CA	71	23038	21	24165	23	26040	25	28270	30	28986	31
110-CB	71	23042	21	24169	23	26044	25	28272	30	28988	31
110-DA	71	23050	21	24200	23	26100	25	28274	30	29260	36
110-DB	71	23056	21	24208	23	26108	25	28276	30	29263	36
110-DC	71	23063	21	24225	23	26125	25	28280	30	29280	36
110-EA	71	23067	21	24233	23	26133	25	28282	30	29285	36
110-EB	71	23100	21	24240	23	26140	25	28284	30	29290	36
110-EC	71	23106	21	24244	23	26144	25	28286	30	29295	36
110-ED	71	23113	21	24250	23	26200	25	28288	30	29310	36
110-FD	71	23117	21	24258	23	26208	25	28292	30	29311	36
110-FE	71	23125	21	24265	23	26225	25	28296	30	29312	36
112-A	71	23131	21	24325	23	26233	25	28297	30	29315	36
112-B	71	23133	21	24425	23	26240	25	28299	30	29316	36
112-C	71	23138	21	24500	23	26244	25	28502	30	29317	36
112-D	71	23142	21	24508	23	26246	25	28505	30	29330	36
112-E	71	23150	21	24525	23	27752	32	28570	30	29331	36
113-A15	71	23156	21	24533	23	27754	32	28572	30	29332	36
113-A2	71	23163	21	24600	23	27759	32	28574	30	29333	36
113-A25	71	23167	21	24608	23	27770	32	28576	30	29335	36
113-A3	71	23200	21	24615	23	27772	32	28580	30	29336	36
113-A35	71	23206	21	25000	27	27774	32	28582	30	29337	36
113-B15	71	23213	21	25008	27	27776	32	28584	30	29338	36
113-B2	71	23225	21	25025	27	27780	32	28586	30	29384	36
113-B25	71	23231	21	25033	27	27782	32	28588	30	29385	36
113-B3	71	23233	21	25040	27	27784	32	28592	30	29435	62
113-B35	71	23238	21	25044	27	27786	32	28596	30	29436	62
113-C15	71	23244	21	25050	27	27788	32	28597	30	32002	49
113-C2	71	23250	21	25058	27	27852	32	28599	30	32003	49
113-C25	71	23256	21	25065	27	27854	32	28732	31	33112N	52
113-C3	71	23263	21	25069	27	27859	32	28735	31	33112RK	39
113-C35	71	23300	21	25100	27	27870	32	28752	31	33112RKB	52
113-D15	71	23306	21	25108	27	27872	32	28754	31	33112RKB	39, 52
113-D2	71	23313	21	25125	27	27874	32	28759	31	33113N	52
113-D25	71	23317	21	25133	27	27876	32	28770	31	3311RK	52
113-D3	71	23325	21	25140	27	27880	32	28772	31	4VZR-P	37
113-D35	71	23331	21	25144	27	27882	32	28774	31	4VZR-S	37
116-A	71	23338	21	25150	27	27884	32	28776	31	40200	37
116-B	71	23342	21	25158	27	27886	32	28780	31	40201	37
116-C	71	23500	21	25165	27	27888	32	28782	31	40202	37
116-D	71	23506	21	25169	27	27952	32	28784	31	40203	37
121-A	71	23510	21	25200	27	27954	32	28786	31	40204	37
121-B	71	23513	21	25208	27	27959	32	28788	31	40205	37
121-C	71	23521	21	25225	27	27970	32	28832	31	40206	37
121-D	71	23525	21	25233	27	27972	32	28835	31	40207	37
121-E	71	23531	21	25240	27	27974	32	28852	31	42019	65
121-F	71	23533	21	25244	27	27976	32	28854	31	81LB-4	71
122-A	71	23535	21	25246	27	27980	32	28859	31	96822	65
122-B	71	23538	21	25250	27	27982	32	28870	31	96823	65
122-C	71	23540	21	25258	27	27984	32	28872	31	A10971	63
122-D	71	23546	21	25265	27	27986	32	28874	31	A10972	63
122-E	71	24000	23	25269	27	27988	32	28876	31	A10973	63
11175	65	24008	23	25325	27	28102	30	28880	31	A31002	44

PRODUCT INDEX

PART #	PG.	PART #	PG.	PART #	PG.	PART #	PG.	PART #	PG.	PART #	PG.
A31003	44	A31736	47	AF-13455	53	CL-60R	42	CLE-1200R	40	D10053	9
A31004	44	A31851	46	AF-13457	53	CL-60Y	42	CLE-1200Y	40	D10160	9
A31004-CJ	48	A31852	46	AF-13550	53	CL-72B	42	CLP-6B	41	D10162	9
A31004S	44	A31853	46	AVK-001	48	CL-72R	42	CLP-6R	41	D10244	9
A31005	44	A31854	46	B1-3	67	CL-72Y	42	CLP-6Y	41	D10266	9
A31006	44	A31856	46	B1-4	67	CL2HD-36	42	CLS-36B	39	D10436	8, 42
A31006S	44	A31864	46	B1-6	67	CL2HD-48	42	CLS-36R	39	D10472	8, 42
A31008	44	A31985	50	B1-8	67	CL2HD-60	42	CLS-36Y	39	D10636	8, 42
A31009	44	A31985-100	50	B1-10	67	CL2HD-72	42	CLS-48B	39	D10660	8, 42
A31011	44	A31986	50	B1-12	67	CL4HD-36	42	CLS-48R	39	DS-20000	14
A31012	45	A31992	15, 50	B2-3	67	CL4HD-48	42	CLS-48Y	39	DS-MOD	14
A31134	45	A31992-100	50	B2-4	67	CL4HD-60	42	CLS-60B	39	DSR-10	14
A31135	45	A31997	49	B2-5	67	CL4HD-72	42	CLS-60R	39	DSR-20	14
A31136	45	A31998	49	B2-6	67	CL6-36	41	CLS-60Y	39	DSR-30	14
A31138	45	A31999	49	B2-8	67	CL6-36Y	41	CLS-72B	39	DV-EP6	9, 77, 78
A31140	45	A31999-25	49	B2-10	67	CL6-48	41	CLS-72R	39	DV-EP8	9, 77, 78
A31142	45	A31999-100	49	B2-12	67	CL6-48Y	41	CLS-72Y	39	DV-F6	9
A31144	45	A32004	48	BRZ-1000	63	CL6-60	41	CLS-120B	39	DV-F8	9
A31148	45	A32008	49	BS-4	59	CL6-60Y	41	CLS-120R	39	DV-T1	8
A31154	45	A32008-B	49	BS-5	59	CL6-72	41	CLS-120Y	39	DV-3E	7
A31155	45	A32008-BX	49	BS-6	59	CL6-72Y	41	CLS-300B	39	DV-3E-250	7
A31156	45	A32100	49	BS-7	59	CL64-60	42	CLS-300R	39	DV-3E-250EU	7
A31160	45	A32101	49	BS-8	59	CL6HD-36	42	CLS-300Y	39	DV-3E-250UK	7
A31162	45	A32500N	48	BS-10	59	CL6HD-48	42	CLS-600B	39	DV-4E	7
A31164	45	A32501N	48	BS-12	59	CL6HD-60	42	CLS-600R	39	DV-4E-250	7
A31168	45	A32504	49	BS-55	59	CL6HD-72	42	CLS-600Y	39	DV-4E-250EU	7
A31199	45	A32505N	48	BS-77	59	CL84-60	42	CLS-900B	39	DV-4E-250UK	7
A31200	45	A32525N	48	C1-4	67	CLB-36	40	CLS-900R	39	DV-6E	7
A31201	45	A32600	48	C1-6	67	CLB-48	40	CLS-900Y	39	DV-6E-250	7
A31202	45	A32601	48	C33804	63	CLB-60	40	CLS-1200B	39	DV-6E-250EU	7
A31204	45	A32602	48	C33808	63	CLB-72	40	CLS-1200R	39	DV-6E-250UK	7
A31234	47	A32603	48	C33808-CTN	63	CLBV-36B	40	CLS-1200Y	39	DV-18	11, 15
A31235	47	A32604	48	CCLBV-36	40	CLBV-36R	40	CLSB-36B	39	DV-22N	11
A31236	47	A32605	48	CCLBV-48	40	CLBV-36Y	40	CLSB-36R	39	DV-24N	11
A31238	47	A32700	48	CCLBV-60	40	CLBV-48B	40	CLSB-36Y	39	DV-26N	11
A31334	45	A32701	48	CCLBV-72	40	CLBV-48R	40	CLSB-36Y	39	DV-29	16
A31335	45	A32702	48	CCLE-36	40	CLBV-48Y	40	CLSB-48B	39	DV-40	10
A31336	45	A32703	48	CCLE-48	40	CLBV-60B	40	CLSB-48R	39	DV-40AC	10
A31338	45	A32704	48	CCLE-60	40	CLBV-60R	40	CLSB-48Y	39	DV-40C	10
A31340	45	A32704	48	CCLE-72	40	CLBV-60Y	40	CLSB-60B	39	DV-40HK	10
A31342	45	A32804	44	CCLE4-36	40	CLBV-72B	40	CLSB-60R	39	DV-41	10
A31344	45	A32805	44	CCLE4-48	40	CLBV-72R	40	CLSB-60Y	39	DV-42N	5
A31348	45	A32806	44	CCLE4-60	40	CLBV-72Y	40	CLSB-72B	39	DV-42N-250	5
A31424	47	A32808	44	CCLE4-72	40	CLE-36B	40	CLSB-72R	39	DV-42N-250EU	5
A31434	47	A32810	44	CCLS-36	39	CLE-36R	40	CLSB-72Y	39	DV-42N-250UK	5
A31444	47	A32812	44	CCLS-48	39	CLE-36Y	40	CLV-6B	41	DV-85N	5
A31452	46	A32814	44	CCLS-60	39	CLE-48B	40	CLV-6BL	41	DV-85N-250	5
A31454	46	A32818	44	CCLS-72	39	CLE-48R	40	CLV-6R	41	DV-85N-250EU	5
A31482	46	A32904	44	CCLS4-36	39	CLE-48Y	40	CLV-6Y	41	DV-85N-250UK	5
A31484	46	A32905	44	CCLS4-48	39	CLE-60B	40	CLV-36B	41	DV-142N	5
A31492	46	A32906	44	CCLS4-60	39	CLE-60R	40	CLV-36R	41	DV-142N-250	5
A31494	46	A32908	44	CCLS4-72	39	CLE-60Y	40	CLV-36Y	41	DV-142N-250EU	5
A31512	46	A32910	44	CCLSB-36	39	CLE-72B	40	CLV-48B	41	DV-142N-250UK	5
A31514	46	A32912	44	CCLSB-48	39	CLE-72R	40	CLV-48R	41	DV-200N	5
A31520	47	A32914	44	CCLSB-60	39	CLE-72Y	40	CLV-48Y	41	DV-200N-250	5
A31522	46	A33000	50	CCLSB-72	39	CLE-120B	40	CLV-60B	41	DV-200N-250EU	5
A31544	47	A33004	47	CCLV-6	41	CLE-120R	40	CLV-60R	41	DV-200N-250UK	5
A31614	47	A33500	52	CCLV-36	41	CLE-120Y	40	CLV-60Y	41	DV-285N	5
A31720	47	A33600	53	CCLV-48	41	CLE-300B	40	CLV-72B	41	DV-285N-250	5
A31722	47	A34000	15, 17, 52	CCLV-60	41	CLE-300R	40	CLV-72R	41	DV-285N-250EU	5
A31723	47	A34000D	10, 11	CCLV-72	41	CLE-300Y	40	CLV-72Y	41	DV-285N-250UK	5
A31724	47	AC-13430	53	CL-36B	42	CLE-600B	40	CLV6-6BL	41	DV-291	16
A31725	47	AC-13435	53	CL-36R	42	CLE-600R	40	CLV6-6Y	41	DV-292	16
A31726	47	AC-15530	53	CL-36Y	42	CLE-600Y	40	CLV6-36	41	DV-293	16
A31727	47	AC-15535	53	CL-48B	42	CLE-900B	40	CLV6-48	41	DV-294	8, 16
A31728	47	AF-13450	53, 80	CL-48R	42	CLE-900R	40	CLV6-60	41	DV-295	16
A31729	47	AF-13451	53	CL-48Y	42	CLE-900Y	40	CLV6-72	41	DVO-1	8
A31734	47	AF-13452	53	CL-60B	42	CLE-1200B	40	CV-20004	52	DVO-12	8
								CV-20006	52	DVO-24	8

PRODUCT INDEX

PART #	PG.	PART #	PG.	PART #	PG.	PART #	PG.	PART #	PG.	PART #	PG.
E1-2A	67	FP-C-283	67	M2-435	33	M4-22231	28	NCE-4	51	P90010	50
E1-3A	67	FU-4B-168	68	M2-460	33	MKDS02	75	NCG-4	51	P90011	50
E1-4A	67	FU-4B-210	68	M2-465	33	MKDS03	75	NCG-12	51	P90012	8,9
E1-4B	67	FU-4B-283	68	M2-800	34	MKDS04	75	NCG-50	51	P90012	42, 52
E1-4C	67	FU-4C-168	68	M2-805	34	MKDS05	75	NCG-CJ	51	P90016	42
E1-5A	67	FU-4C-210	68	M2-810	34	MKDS22	75	NCM-12	51	P90022	39
E1-5B	67	FU-4C-283	68	M2-815	34	MKDS24	75	NCM-CJ	51	P90024	39
E1-5C	67	FU-6C-168	68	M2-820	34	MKDS51	74	NCP-4	51	P90513	52
E1-6A	67	FU-6C-210	68	M2-825	34	MKDS52	74	NCP-12	51	P90514	40
E1-6B	67	FU-6C-283	68	M2-828	34	MKDS55	74	NCP-50	51	PR-1	77, 78
E1-6C	67	GTBG-12	62	M2-829	34	MKDS56	74	NCP-CJ	51	PR-2	77, 78
E1-6D	67	GTBG-16	62	M2-830	34	MKDS58	74	NCU-4	51	PR-3	77, 78
E1-6E	67	HNS4-4	68	M2-831	34	MKDS59	74	NCU-12	51	PR-4	77
E1-8B	67	HNS4-6	68	M2-851	34	MKDS63	74	NCU-50	51	PR-5	77
E1-8C	67	HNS4-8	68	M2-856	34	MKDS65	81	NCU-CJ	51	PR-7	77
E1-8D	67	HNS4-10	68	M2-860	35	MR-409	79	NFT5-4	50, 77, 78	PR-10	78
E1-8E	67	HNS4-12	68	M2-865	35	MR-444	81	NFT5-4-100	50	PR-18	77, 78
E1-10C	67	K1-1	67	M2-870	35	MR-446	81	NFT5-4-101	68	PR-22	77, 78
E1-10D	67	K1-3	67	M2-875	35	MR-501B	80, 81	NFT5-4-CJ	48	PR-31	77, 78
E1-10E	67	K1-5	67	M2-880	35	MR-501R	80, 81	NFT5-6	50, 77, 78	PR-32	77
E1-12D	67	K1-8	67	M2-885	35	MR-501Y	81	NFT5-6-100	50	PR-35	77
E1-12E	67	K1-D	68	M2-890	35	MR-502	81	NFT5-6-101	68	PR-39	78
E2-2	67	K1-E	68	M2-895	35	MR-503	79-81	NFT5-8	50, 77	PR-40	77, 78
E2-3	67	LC-4	37	M2-924	34	MR-504	81	NRS4-43	68	PR-42	77
E2-4	67	LC-5	37	M2-925	34	MR-504B	81	NRS4-54	68	PR-45	77
E2-5	67	LD-5000	13	M2-951	34	MR-505	79-81	NRS4-64	68	PR-52	77
E2-6	67	LD-CS	13	M2-956	34	MR-506	81	NRS4-64	68	PR-54	77, 78
E2-8	67	LD-PK	13	M2-21125	19	MR-508	80	NRS4-65	68	PR-56	77
E2-10	67	LD-RF5	13	M2-21125B	19	MR-509	79-81	NRS4-86	68	PR-58	77, 78
E2-12	67	LD-S100	13	M2-21131	19	MR-516	79, 80, 81	NRS4-108	68	PR-59	77, 78
E3-4A	67	LD-TV	13	M2-21131B	19	MR-517	37	NRS4-1210	68	PR-62	77, 78
E3-4B	67	LT-456	50	M2-21525	19	MR-520	80	NS4-3	68	PR-63	78
E3-5B	67	LT-810	50	M2-21525B	19	MR-521	80	NS4-4	68	PR-65	78
E3-6A	67	M2-HP	29	M2-21531	19	MR-525	79, 81	NS4-4-5	68	PR-75	77
E3-6B	67	M2R-P	37	M2-21531B	19	MR-531	81	NS4-4-CS	68	PR-76	77
E3-6C	67	M2R-S	37	M2-22125	19	MR-533	37	NS4-5	68	PR-200	77
E3-6D	67	M2-5	19	M2-22131	19	MR-544	81	NS4-6	68	PR-201	77
E3-8C	67	M2-5-410A	19	M2-22225	19	MR-546	81	NS4-6-5	48	PR-202	77
E3-8D	67	M2-5-410A-SS	19	M2-22231	19	MR-550	80	NS4-6-CS	68	PR-203	77
E3-8E	67	M2-5-410AB	19	M2-22244	19	MR-560	80	NS4-8	68	PR-204	77
E3-10D	67	M2-5-410AM	19	M2-22325	19	MR-590	36	NS4-8-5	48	PR-205	77, 78
E3-10E	67	M2-5-HP	29	M2-22425	19	MR-593	36	NS4-8-CS	68	PR-206	77, 78
E4-44	67	M2-5B	19	M2-22525	19	MR-594	36	NS4-10	68	PR-207	77, 78
E4-66	67	M2-6	19	M2-22531	19	MR-595	36	NS4-10-5	48	PR-208	77, 78
E4-88	67	M2-6B	19	M2-23125	19	MR-596	36	NS4-10-CS	68	PR-209	77
ER2-64	67	M2-8	19	M2-23131	19	MR-597	36	NS4-12	68	PR-210	77
ER2-84	67	M2-8B	19	M2-23225	19	MR-601	79	NS4-12-CS	68	PR-211	77
ER2-86	67	M2-8-410A	19	M2-23231	19	MR-605	79	NS4-14	68	PR-214	77
ER2-108	67	M2-8-410AB	19	M4R-P	37	MR-607	79	NST4-4	68	PR-215	77
ES2-44	67	M2-8-410AM	19	M4R-S	37	MR-610	81	NST4-6	68	PR-216	77
ES2-66	67	M2-36	19	M4-5	28	N4-4	68	NST4-8	68	PR-217	77
ES2-68	67	M2-36B	19	M4-5-410A	28	N4-5-5	68	NST4-10	68	PR-300	77
ES2-88	67	M2-102N	79-81	M4-5-410AB	28	N4-6	68	NV62-4	55	PR-301	77
ES4-44	67	M2-106	37	M4-5B	28	N4-8	68	P2-3	68	PR-302	77
ES4-66	67	M2-108	37	M4-8	28	N4-10	68	P2-4	68	PR-303	77
ES4-88	67	M2-250	33	M4-8-410A	28	N4-12	68	P2-5	68	PR-304	77
ES4-1010	67	M2-250B	33	M4-8-410AB	28	N5-3	68	P2-6	68	PR-305	77
ES4-1212	67	M2-250C	33	M4-8B	28	N5-4	68	P2-8	68	PR-308	77
EZ-40288	50	M2-300	80	M4-36	28	N5-5	68	P2-10	68	PR-311	77
EZ-40288-126	50	M2-350	33	M4-36B	28	N5-6	68	P2-12	68	PR-314	77
FP-A-168	67	M2-355	33	M4-21125	28	N5-8	68	P509	50, 52, 53	PR-315	77, 78
FP-A-210	67	M2-400	35	M4-21125B	28	N5-10	68	P509-25	50	PR-403	78
FP-A-283	67	M2-405	35	M4-21131	28	N5-12	68	P510	53	PR-404	78
FP-B-168	67	M2-410	33	M4-21131B	28	NC-A31004	51	P511	40, 41	PR-406	78
FP-B-210	67	M2-415	33	M4-22125	28	NC-GS	51	P90008	42	PR-500	77
FP-B-283	67	M2-420	33	M4-22131	28	NC-KEY	51	P90009	8-11, 16,	PR-501	77
FP-C-168	67	M2-425	33	M4-22225	28	NC-RS	51		42, 50, 52, 77	PS-10	62

PRODUCT INDEX

PART #	PG.	PART #	PG.	PART #	PG.	PART #	PG.	PART #	PG.	PART #	PG.
PS-25	62	RT70017D	56, 57	T21005	59	U1-4B-5	69	UR2-84	71	V34350	54
PS-50	62	RT70020	56	T21006	59	U1-4C-5	69	UR2-86	71	V34400	54-55
PS-100	62	RT70021	56	T21007	59	U1-4D	69	UR2-106	69	V34401	54-55
QC-13445-134a	53	RT70027	56	T21008	59	U1-5A	69	UR2-108	69	V34402	54-55
QC-E3	52	RT70029	56	T21010	59	U1-5B	69	UR2-128	69	V34404	54-55
QC-E4	52	RT70030	57	T21012	59	U1-5C	69	UR2-1210	69	V34406	54-55
QC-E5	52	RT70045	57	T21014	59	U1-6A	69, 81	UR3-43	69	V34407	54-55
QC-E64	9, 52	RT70051D	57	T21024	59	U1-6B	69, 79	UR3-46	69	V34408	54-55
QC-S3	52	RT70056D	56	T21124	62	U1-6C	69	UR3-48	69	V34409	54-55
QC-S4	52	RT70057D	57	T21125U	62	U1-6D	69	UR3-64	69	V34500	54
QC-S4A	52	RT70060	57	T21126U	62	U1-6E	69	UR3-84	69	V34501	54
QC-S4A-134a	53	RT70061D	57	T21127	62	U1-8A	69	UR3-86	69	V34502	54
QC-S4B	52	RT70075	57	T21127U	62	U1-8B	69	UR3-108	69	V34504	54
QC-S46	52	RT70105	56	T21294	59	U1-8C	69	UR3-810	69	V34506	54
QC-S5	52	RT70142	57	T3-4A	69	U1-8D	69	UR3-1012	69	V34507	54
QC-S5S	52	RT70401	56	T3-4B	69	U1-8E	69	UR3-1210	69	V34508	54
QC-S64	9, 52	RT70402	56	T3-5B	69	U1-10B	69	US3-44	69	V34509	54
QC-S65	52	RT70521	57	T3-6B	69	U1-10C	69	US3-45	69	V34510	54
RG-33600	53	RT70522	57	T3-6C	69	U1-10D	69	US3-46	69	V34511	54
RT11006	57	RT70523	57	T3-6D	69	U1-10E	69	US3-64	69	V34525	54
RT12318	60	RT70531	57	T3-8C	69	U1-12C	69	US3-65	69	V34900	55
RT12428	62	RT70532	57	T3-8D	69	U1-12D	69	US3-66	69	V34901	55
RT15031V	63	RT70533	57	T3-10D	69	U1-12E	69	US3-68	69	V34905	55
RT15032V	61	RT70558	57	T30251	62	U1-14E	69	US3-86	69	V34910	55
RT15033V	61	RT90614	58	T6-4	71	U2-2	69	US3-88	69		
RT15222X	61	RT99016	56	TC-26-100	63	U2-3	69	US3-108	69		
RT15223X	61	SCT-1030	53	TC-26-16	63	U2-4-5	69	US3-610	69		
RT15224X	61	SH-35N	15	TC-31-100	63	U2-5	69	US3-810	69		
RT15225X	61	SH-36N	15	TC-31-12	63	U2-6-5	69	US3-1010	69		
RT15226X	61	SH-51	15	TC-36-100	63	U2-8	69	US3-1012	69		
RT15227X	61	SH-54	15	TC-36-12	63	U2-10	69	US3-1014	69		
RT16001	61	SH-55	15	TC-42-100	63	U2-12	69	US3-1212	69		
RT16002	61	SH-56	15	TC-42-12	63	U2-14	69	US3-1214	69		
RT16101	61	SK-35N	15	TC-44-100	63	U3-2A	69	US4-4	70		
RT16102	61	SK-36N	15	TC-44-12	63	U3-3A	69	US4-5	70		
RT16201	61	T1-4A	68	TC-49-100	63	U3-4A	69	US4-6	70		
RT16202	61	T1-4B	68	TC-49-11	63	U3-4B	69	US4-8	70		
RT21652B	56-57	T1-4C	68	TC-50-100	63	U3-4C	69	US4-10	70		
RT21655	57	T1-5B	68	TC-50-11	63	U3-5A	69	US5-44	70		
RT21660	57	T1-6B	68	TC-54-100	63	U3-5B	69	US5-66	70		
RT22124	62	T1-6C	68	TC-54-11	63	U3-6A	69	US5-88	70		
RT222402	60	T1-6D	68	TC-55-100	63	U3-6B	69	US5-1010	70		
RT222601	60	T1-8B	68	TC-55-11	63	U3-6C	69	US5-1212	70		
RT23022X	58	T1-8C	68	TC-59-10	63	U3-6D	69	UX1-4A	70		
RT24134	58	T1-8D	68	TC-59-100	63	U3-8B	69	UX1-4B	70		
RT24504	58	T1-10C	68	TC-64-10	63	U3-8C	69	UX2-4	70		
RT25131	58	T1-10D	68	TC-64-100	63	U3-8D	69	V34200	54-55		
RT25136	58	T2-3	68	TC-70-100	63	U3-8E	69	V34201	54-55		
RT25140	58	T2-4	11, 68	TC-70-12	63	U3-10C	69	V34202	54-55		
RT25141	58	T2-5	68	TC-75-100	63	U3-10D	69	V34203	54-55		
RT25142	58	T2-6	68	TC-75-9	63	U3-10E	69	V34204	54-55		
RT25151	58	T2-8	68	TC-80-10	63	U4-4	70	V34206	54-55		
RT25913	58	T2-10	68	TC-80-100	63	U4-6	70	V34207	54-55		
RT25914	58	T2-12	68	TC-85-100	63	U4-8	70	V34208	54-55		
RT26036	61	T2-HKA	62	TC-85-9	63	U4-10	70	V34209	54-55		
RT26715	61	T20095	59	TC-90-100	63	U4-12	70	V34210	54-55		
RT52000	57	T20195	59	TC-90-7	63	U5-4A	70	V34211	54-55		
RT52010	57	T20203	59	TC-100-10	63	U5-4B	70	V34300	54		
RT52011	57	T20275	59	TC-100-100	65	U5-6B	70	V34301	54		
RT52030	57	T20351	61	TR2-446	69	U5-8C	70	V34302	54		
RT52042	57	T20352	61	TR2-664	69	U5-8D	70	V34303	54		
RT52176	61	T20353	61	TR2-668	69	U6-4A	70	V34304	54		
RT52178	61	T20500	59	TR2-886	69	U6-4B	70	V34306	54		
RT70007B	56	T21000	59	U1-2A	69	UR2-43	71	V34307	54		
RT70007X	56	T21002	59	U1-3A	69	UR2-54	71	V34308	54		
RT70015	56	T21003	59	U1-3B	69	UR2-64	71	V34309	54		
RT70017B	56, 57	T21004	59	U1-4A	69, 79-81	UR2-65	71	V34310	54		
								V34311	54		

JB SALES AGENTS

INTERNATIONAL SALES AGENTS

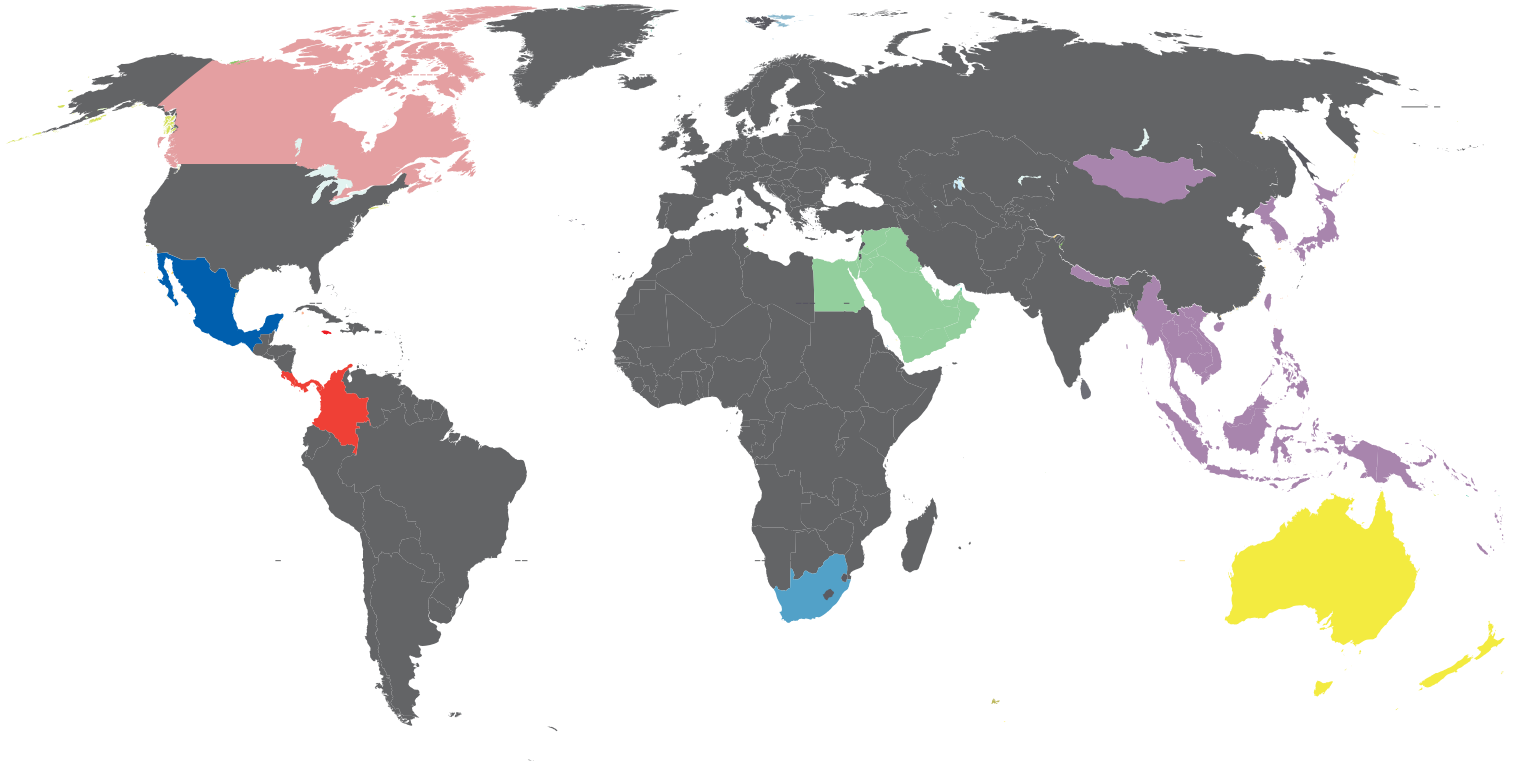

WILDON MARKETING
Bill Northam
(Oshwa, Ontario, Canada)
Territory: CANADA
Ph: 905-432-6822
E: bdnortham@rogers.com

HARTLAND CONTROLS
Amer Jaber
(Amman, Jordan)
Territory: MIDDLE EAST
Ph: 962-6-552-3615
E: ajaber@hartlandcontrols.com

MRE INTERNATIONAL GROUP
Shepard Goodman
(Pacific Palisades, CA USA)
Territory: FAR EAST
Ph: 310-459-1333
E: acexporter@aol.com

ALLTEMP PRODUCTS CO, LTD
(Pickering, Ontario, Canada)
Territory: CANADA
Ph: 800-263-4624
E: sales@alltemp.ca

EMEA ASSOCIATES
Eugene O'Rourke
(San Diego, CA USA)
Territory: REPUBLIC OF SOUTH AFRICA
Ph: 858-349-2927
E: cafr01@san.rr.com

PRO PIPE SUPPLIES
Brett Spicer
Territory: AUSTRALIA, NEW ZEALAND
Ph: 08 8186 4666
E: brett@propipesupplies.com.au

GUNDER & ASSOCIATES
Pedro Morales
(Monterrey, Mexico)
Territory: MEXICO
Ph: 011-52 (81)-8347-5542
E: gunder@intercable.net

JB INDUSTRIES
(Aurora, IL USA)
Territory: WORLDWIDE
Ph: 011-630-851-9444
E: sales@jbind.com

**JB continues to look for international partners.
Please send inquiries to our global manager dgroberg@jbind.com**

JB SALES AGENTS

UNITED STATES SALES AGENTS

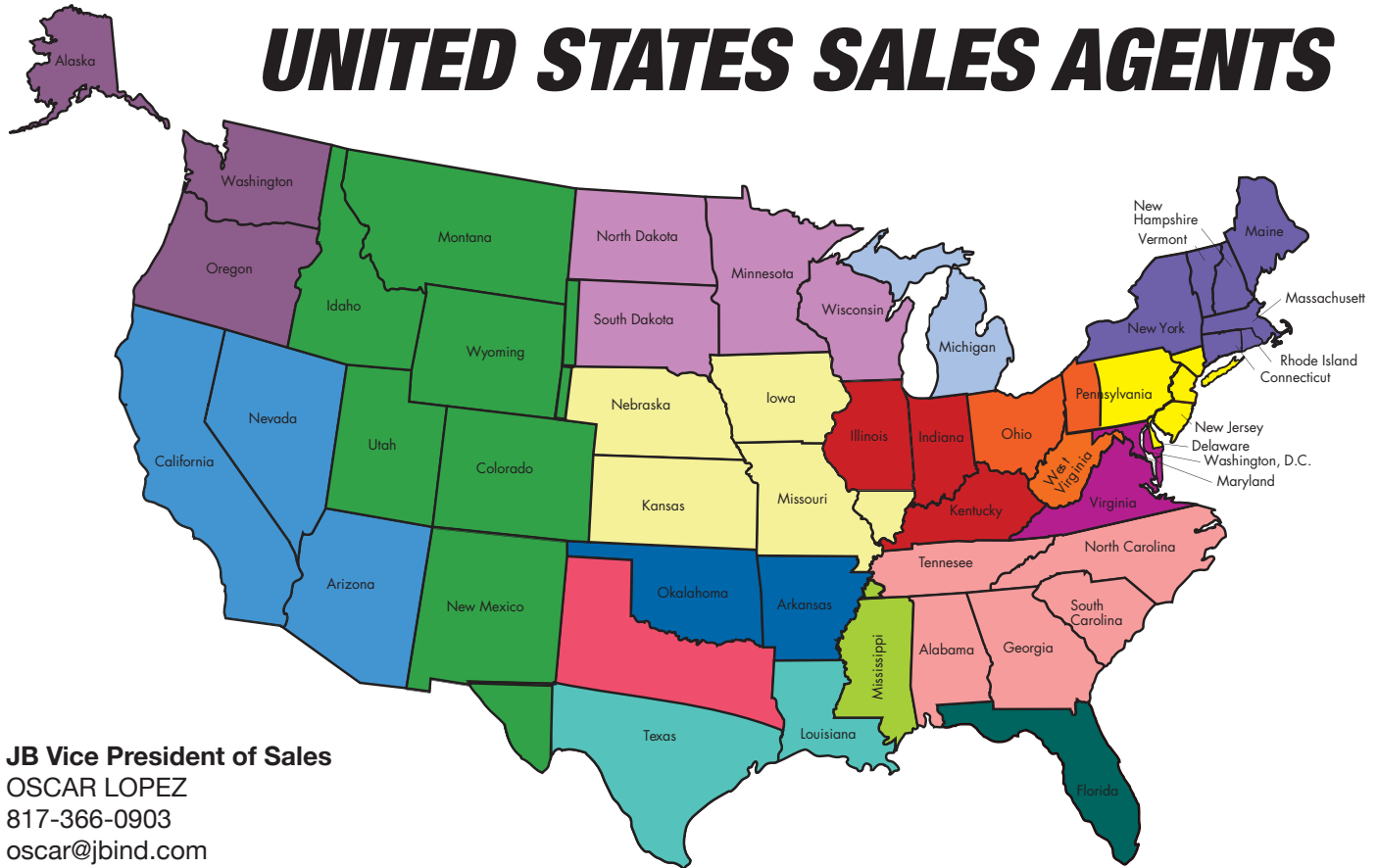

JB Vice President of Sales

OSCAR LOPEZ
817-366-0903
oscar@jbind.com

- | | | |
|--|---|---|
| <p> GIMPER IV, INC.
Dan Clark
Ph: 518-885-8901
E: Gimper2@aol.com</p> | <p> CHRISTIAN & COMPANY
Jeff Christian
Ph: 248-851-5660
E: jjchvac@aol.com</p> | <p> SUPERIOR SALES & SERVICE
Mike Lochridge
Ph: 832-418-1412
E: m.lock@earthlink.net</p> |
| <p> BIRDSONG & ASSOCIATES
Bill Birdsong
Ph: 732-854-9609
E: BirdsongNJ@aol.com</p> | <p> G. MILLER COMPANY
Brian Miller
Ph: 815-964-5692
E: office@gmillercompany.com</p> | <p> OSCAR LOPEZ
Ph: 817-366-0903
E: oscar@jbind.com</p> |
| <p> ROBERT H HESTER LLC
Robert Hester
Ph: 540-336-3940
E: rhh71@msn.com</p> | <p> RAC SALES
Keith Rinderknecht
Ph: 763-785-7000
E: racsales@racsalesinc.com</p> | <p> MJM ASSOCIATES INC.
Camden Marklowitz
Ph: 303-790-7000
E: c1am@aol.com</p> |
| <p> SOUTHLAND MARKETING INC.
John Forbes
Ph: 770-760-0627
E: johnfsmi@aol.com</p> <p>Greg Moore
E: gregmooresmi@aol.com</p> | <p> CENTRAL STATES MARKETING
William J. Hosner
Ph: 314-517-3002
E: bhosnercsm@aol.com</p> | <p> WESTERN COMPONENT SALES
George Kief
Ph: 888-927-2248
E: george@westerncomponent-sales.com</p> |
| <p> LEONE GREEN & ASSOCIATES
Frank Leone
Ph: 800-843-6034
E: sales@leonegreen.com</p> | <p> RIDDELL ENTERPRISES LTD.
Bill Riddell
Ph: 918-622-8918
E: reltd@sbcglobal.net</p> | <p> WESTERN COMPONENT SALES
Corey Smith
E: corey@westerncomponent-sales.com</p> |
| <p> THE EBY COMPANY
Tom Eby
Ph: 440-232-1144
E: treby@theebyco.com</p> | <p> SARRIO SALES, INC
Barry Sarrio
Ph: 9011-854-5004
Barry@sarriosales.com</p> | <p> WESTERN COMPONENT SALES
Zack Bray
Ph: 888-927-2248
E: zack@westerncomponent-sales.com</p> |



**PO BOX 1180
601 NORTH FARNSWORTH AVE
AURORA, IL 60505**

P.630.851.9444 P.800.323.0811

F.630.851.9448 F.800.552.5593

SALES@JBIND.COM

WWW.JBIND.COM



You Tube

FOLLOW US TO KEEP UP-TO-DATE ON THE LATEST JB NEWS!