



aerospace  
 climate control  
 electromechanical  
 filtration  
 fluid & gas handling  
 hydraulics  
 pneumatics  
 process control  
 sealing & shielding



# RACE Catalogue 301 UK

Condensed Catalog of Sporlan Products

RACE Catalogue 301 UK, April 2010

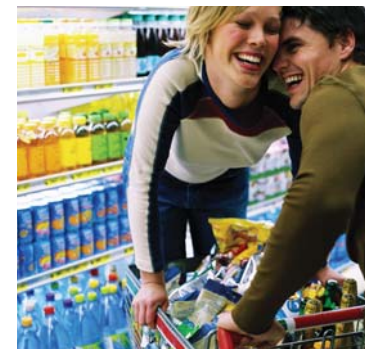

ENGINEERING YOUR SUCCESS.

# CONDENSED CATALOG 301

April 2010

This catalog is a condensed version of the complete Sporlan Catalog. By including a minimum of engineering information we are able to provide a concise reference to pertinent data and specifications on Sporlan products.

For additional engineering information, a complete Sporlan Catalog or CD, please consult your nearest Sporlan Wholesaler or email [europesold@parker.com](mailto:europesold@parker.com).

## CONTENTS

	Page	
Acid Test Kits . . . . .	40	<b>*For complete product information see Bulletin number</b> 40-10
Accumulators . . . . .	38	40-10-7
Catch-All® Filter-Driers Liquid & Suction Line . . . . .	31	40-10
Crankcase Pressure Regulating Valves . . . . .	45	90-10
Defrost Differential Pressure Regulating Valves . . . . .	50	Contact your Sporlan Sales Engineer
Discharge Bypass Valves . . . . .	44	90-40
Electronic Temperature Control Systems . . . . .	54	100-9, 100-20, 100-20-1, 100-20-2, 100-40, 100-50-1, 100-60
Evaporator Pressure Regulating Valves . . . . .	51	90-20, 90-20-1 & 90-20-2
Head Pressure Control Valves . . . . .	47	90-30
“OF” Series Oil Filters . . . . .	62	110-10
Oil Level Control System . . . . .	60	110-10
Receivers . . . . .	40	20-10
Refrigerant Distributors . . . . .	24	20-10
Reversible Heat Pump Filter-Driers . . . . .	37	40-10
See • All® Moisture & Liquid Indicators . . . . .	41	70-10
Solenoid Valves . . . . .	25	30-10
Suction Filters . . . . .	42	80-10
Thermostatic Expansion Valves . . . . .	3	10-9, 10-10
Three Way Heat Reclaim Valves . . . . .	28	30-20

\*To request individual Sporlan Product Bulletins, consult your nearest Sporlan Wholesaler or email [europesold@parker.com](mailto:europesold@parker.com).

# THERMOSTATIC EXPANSION VALVES

## 10 Outstanding Features & Benefits of Sporlan Thermostatic Expansion Valves

- **Selective Thermostatic Charges** Designed to provide optimum performance for all applications—air conditioning and heat pump, medium and low temperature refrigeration.
  - **Thermostatic Element Design** Long lasting and field proven stainless steel diaphragm and welded element construction.
  - **Diaphragm Design** Large flat diaphragm permits precise valve control.
  - **Replaceable Thermostatic Elements** Field replaceable elements on all standard valves.
  - **Balanced Port Design** Provides perfect pin and port alignment, and prevents changes in pressure drop across the valve from influencing valve operation. Provides excellent control on applications with widely varying operating conditions.
  - **Pin Carrier Design (Conventional Valves)** Provides precise pin and port alignment, and tighter seating.
  - **Accessible Internal Parts** Durable, leakproof body joint construction allows the valve to be disassembled, and the internal parts cleaned and inspected.
  - **Materials of Construction** Pin and port materials offer maximum protection against corrosion and erosion.
  - **Silver Soldered Connections** For leakproof, high strength connection-to-body joints.
- Adjustable Superheat Design** All standard valves are externally adjustable.

## Valve Nomenclature/Ordering Instructions

Combine the letters and numbers in the following manner to obtain the complete valve designation. Also include all connection sizes and the capillary tube length.

### EXAMPLE

<b>O</b>	<b>Z</b>	<b>E</b>	<b>35</b>	<b>GA</b>	<b>7/8" ODF SOLDER</b>	<b>X</b>	<b>1-1/8" ODF SOLDER</b>	<b>X</b>	<b>1/4" ODF SOLDER</b>	<b>X</b>	<b>5'</b>
Body Type	<b>Sporlan Code</b> – Refrigerant Element Label Color Code  <b>V</b> = R-22     Green <b>J</b> = R-134a   Blue <b>S</b> = R-404A   Orange <b>N</b> = R-407C   Lt. Brown <b>F</b> = R-409A   Yellow <b>Z</b> = R-410A   Rose <b>P</b> = R-507     Teal	"E" specifies external equalizer. Omission of letter "E" indicates valve with internal equalizer.	Nominal Capacity in Tons	Thermostatic Charge	Inlet Connection Size and Style		Outlet Connection Size and Style		External Equalizer Connection Size and Style		Capillary Tubing Length Inches or Feet

## Sporlan Selective Charges engineered for peak performance for each specific application Recommended Thermostatic Charges\*







APPLICATION	REFRIGERANT							ACTUAL THERMOSTATIC CHARGES
	22	134a	404A	407C	409A	410A	507	
Air Conditioning	—	JCP60	—	—	FCP60	—	—	FCP60
	VCP100	—	—	NCP100	—	—	—	VCP100
	VGA	—	—	NGA	—	—	—	VGA
	—	—	SCP115	—	—	—	—	SCP115
	—	—	—	—	—	ZCP200	—	ZCP200
Commercial Refrigeration 10°C to -25°C	—	JC	—	—	FC	—	—	FC
	VC	—	—	NC	—	—	—	VC
	—	—	SC	—	—	—	—	SC
	—	—	—	—	—	—	PC	PC
Low Temperature Refrigeration -20°C to -40°C	—	—	—	—	FZ	—	—	FZ
	—	—	—	—	FZP	—	—	FZP
	VZ	—	—	—	—	—	—	VZ
	VZP40	—	—	—	—	—	—	VZP40
	—	—	SZ	—	—	—	PZ	SZ
Extreme Low Temperature Refrigeration -40°C to -75°C	—	—	SZP	—	—	—	PZP	SZP
	VX	—	—	—	—	—	—	VX
	—	—	SX	—	—	—	PX	SX

### \*APPLICATION FACTORS:

1. The Type ZP charges have essentially the same characteristics as the Type Z charge with one exception: they produce a pressure limit Maximum Operating Pressure (MOP). ZP charges are not intended as replacements for Z charges. Each should be selected for its own unique purpose.
2. All air conditioning and heat pump charges are intended for use with externally equalized valves.
3. Type L liquid charges are also available for most commonly used refrigerants in most element sizes.
4. If in doubt as to which charge to use, contact your nearest Sporlan Sales Office with complete system data.
5. The Type X charges are not to be used with "EBS" and "O" valves.







# THERMOSTATIC EXPANSION VALVES

## Quick Reference Guide

VALVE TYPE	SPECS	NOMINAL CAPACITY RANGE (kW)				CONNECTION TYPES	VALVE DESCRIPTION AND APPLICATION
		R-22	R-134a	R-404A & R-507	R-410A		
<b>FB</b> 	Page 6	0.88 thru 14	0.44 thru 10.5	0.44 thru 12.3	—	ODF Solder	Small brass body valve available only with straight through connections and external adjustment. The thermostatic element is not replaceable on valves manufactured prior to 1994. Current models use a replaceable No. 43 element. Typical applications: small capacity air conditioning and refrigeration applications where an external adjustment is desired. Not available for R-410A.
<b>ER</b> 	Page 7	3.5 thru 42	—	—	4.2 thru 50.8	ODF Solder	Small brass body, externally adjustable valve available for R-22 and R-410A air conditioning and heat pump applications. This valve features a balanced port construction and is approved for bi-directional operation. Suitable for replacing OEM type TEVs without internal check valve on these applications. A 60 x 50 mesh inlet strainer is included with 3/8" inlet.
<b>RC</b> 	Page 8	3.5 thru 21	—	—	4.2 thru 25.2	ODF Solder	In addition to the features described above for the R valve, the RC has a built-in check valve to allow bypass flow in the reverse direction. This feature makes this valve type ideally suited for heat pump applications. RC valves are only available externally adjustable.
<b>Q/BQ</b> 	Page 9-11	1.2 thru 17.5	0.58 thru 8.8	0.58 thru 10.5	1.5* thru 21.8	SAE Flare	The brass body Q valve is externally adjustable with a removable cartridge or orifice. The valve body, cartridge and thermostatic element can be supplied as independent components. This allows body, cartridge and element to be assembled and matched to specific system requirements. Inlet connection has a 100 mesh removable strainer screen. Typical applications: Refrigeration applications and external equalized versions may be used on air conditioning. Type BQ same as above, with balanced port construction.  *BQ only
<b>EQ/EBQ</b> 	Page 9-11	1.2 thru 17.5	0.58 thru 8.8	0.58 thru 10.5	1.5* thru 21.8	Extended ODF Solder	Type EQ same as the Type Q except it features extended ODF connections. A 100 mesh insert strainer is provided with the valve. Type EBQ same as EQ with balanced port construction.  *EBQ only
<b>SQ/SBQ</b> 	Page 9-11	1.2 thru 17.5	0.58 thru 8.8	0.58 thru 10.5	1.5* thru 21.8	Extended ODF Solder	Type SQ same as the Type Q valve except it features ODF solder connections and a forged brass inlet fitting with a removable 100 mesh strainer screen which can be cleaned and/or replaced without removing the valve from the line. Type SBQ same as SQ with balanced port construction.  *SBQ only

# THERMOSTATIC EXPANSION VALVES

## Quick Reference Guide

VALVE TYPE	SPECS	NOMINAL CAPACITY RANGE (kW)				CONNECTION TYPES	VALVE DESCRIPTION AND APPLICATION
		R-22	R-134a	R-404A & R-507	R-410A		
<b>S</b> 	Page 12	7 thru 52.5	7 thru 35	7 thru 35	—	ODF Solder	Brass bar body, externally adjustable valve. Inlet has a permanent 12 mesh strainer. General purpose valve for air conditioning and refrigeration applications.
<b>EBS</b> 	Page 13	28 thru 70	17.5 thru 42	21 thru 46	—	Extended ODF Solder	Same physical size as the Type S valve except it features extended ODF connections and a balanced port construction.
<b>O</b> 	Page 14	70 thru 315	42 thru 210	42 thru 193	70 thru 210	ODF Solder	Brass bar body, externally adjustable valve. Inlet has a permanent 12 mesh strainer. This valve features a balanced port construction, and it is suitable for both air conditioning and refrigeration applications. The valve can also be ordered as a bi-directional valve, allowing control of flow in both direction for use on heat pump applications.
<b>H</b> 	Page 16	8.8 thru 70	5.3 thru 42	5.3 thru 42	—	ODF Solder or FPT Flange	Brass bar body, externally adjustable valve with flange connections. Inlet flange bushing has a permanent 16 mesh strainer. The FPT flange connection requires the K-1178 adapter kit. This valve provides the smallest capacity TEVs with flange connections and it is suitable for both air conditioning and refrigeration applications.
<b>M</b> 	Page 17	73.5 thru 147	52.5 thru 87.5	52.5 thru 105	—	ODF Solder or FPT Flange	Cast bronze body, externally adjustable valve with flange connections. Inlet has a 12 mesh strainer. This valve type provides valve capacities greater than the Type H and it is suitable for air conditioning and refrigeration applications. Flanges for the Type M valve are interchangeable with the Type V valve.
<b>V</b> 	Page 18	182 thru 350	123 thru 193	133 thru 245	—	ODF Solder or FPT Flange	Cast bronze body, externally adjustable valve with flange connections. Inlet has a 12 mesh strainer. This valve type features a dual port semi-balanced design. This valve type provides valve capacities greater than the Type M and is suitable for air conditioning and refrigeration applications. Flanges for the Type V are interchangeable with the Type M.
<b>W</b> 	Page 19	473 thru 630	280 thru 385	—	—	ODF Solder Flange	Cast bronze body, externally adjustable valve with flange connections. Inlet has a 12 mesh strainer. This valve type features a dual port semi-balanced design and it is primarily for large capacity chillers. This valve type provides the largest valve capacities available for flange connection TEVs.



# THERMOSTATIC EXPANSION VALVES

22, 134a, 404A, 407C, 409A 507

## Type FB – Knife Edge Joint Standard Cap Tube Length 30 inches (760 mm)

The Type FB valve is an externally adjustable valve designed primarily for use in small capacity refrigeration applications. This valve may also be applied on residential and small commercial air conditioning, and heat pump units. Not available for R-410A.

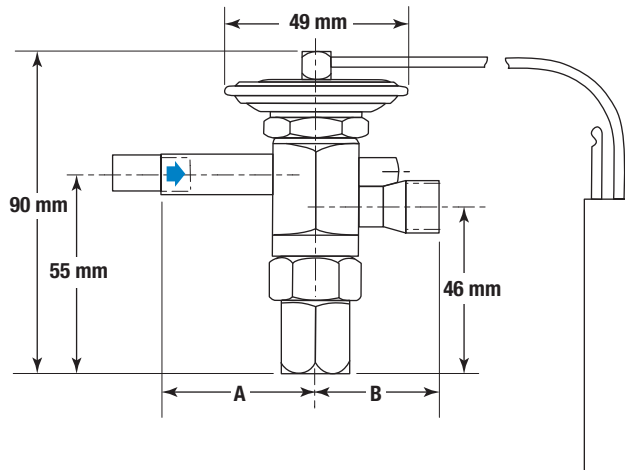

### Dimensions — Connections

VALVE TYPE	FITTING SIZE Inches	mm	
		A	B
FB	1/4 ODF	43	—
	3/8 ODF	43	34
	1/2 ODF	—	34

### Bulb Sizes

THERMOSTATIC CHARGE	mm			
	R-22	R-134a	R-404A	R-507
C	13 OD x 76			
Z & ZP	13 OD x 76	—	13 OD x 76	

Top View

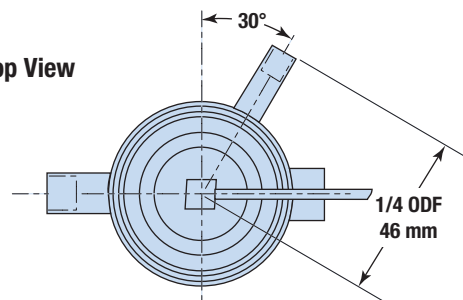

### Specifications — Element Size No. 43, Knife Edge Joint

REFRIGERANT (Sporlan Code)	INTERNAL EQUALIZER	EXTERNAL EQUALIZER	NOMINAL CAPACITY kW of Refrigeration	THERMOSTATIC CHARGES AVAILABLE	STANDARD TUBING LENGTH mm	CONNECTION – Inches <small>Blue figures are standard and will be furnished unless otherwise specified.</small>		NET WEIGHT – kg	SHIPPING WEIGHT – kg
						INLET	OUTLET		
<b>134a (J)</b> 409A (F)	FBJ-1/8	FBJE-1/8	0.44	C	760	1/4, 3/8	3/8, 1/2	0.45	0.68
	FBJ-1/4	FBJE-1/4	0.88			3/8	1/2		
	FBJ-1/2	FBJE-1/2	1.75			3/8	1/2		
	FBJ-1	FBJE-1	3.5			3/8	1/2		
	FBJ-1-1/2	FBJE-1-1/2	5.25			3/8	1/2		
	FBJ-2	FBJE-2	7			3/8	1/2		
	FBJ-2-1/2	FBJE-2-1/2	8.75			3/8	1/2		
<b>404A (S)</b>	FBS-1/8	FBSE-1/8	0.44	C Z ZP	760	1/4, 3/8	3/8, 1/2	0.45	0.68
	FBS-1/4	FBSE-1/4	0.88			3/8	1/2		
	FBS-1/2	FBSE-1/2	1.75			3/8	1/2		
	FBS-1	FBSE-1	3.5			3/8	1/2		
	FBS-1-1/2	FBSE-1-1/2	5.25			3/8	1/2		
	FBS-2	FBSE-2	7			3/8	1/2		
	FBS-3	FBSE-3	10.5			3/8	1/2		
<b>407C (N)</b> 22 (V)	FBN-1/4	FBNE-1/4	0.88	C CP100 GA Z ZP40	760	1/4, 3/8	3/8, 1/2	0.45	0.68
	FBN-1/2	FBNE-1/2	1.75			3/8	1/2		
	FBN-1	FBNE-1	3.5			3/8	1/2		
	FBN-1-1/2	FBNE-1-1/2	5.25			3/8	1/2		
	FBN-2	FBNE-2	7			3/8	1/2		
	FBN-2-1/2	FBNE-2-1/2	8.75			3/8	1/2		
	FBN-3	FBNE-3	10.5			3/8	1/2		
<b>507 (P)</b>	FBP-1/8	FBPE-1/8	0.44	C Z ZP	760	1/4, 3/8	3/8, 1/2	0.45	0.68
	FBP-1/4	FBPE-1/4	0.88			3/8	1/2		
	FBP-1/2	FBPE-1/2	1.75			3/8	1/2		
	FBP-1	FBPE-1	3.5			3/8	1/2		
	FBP-1-1/2	FBPE-1-1/2	5.25			3/8	1/2		
	FBP-2	FBPE-2	7			3/8	1/2		
	FBP-3	FBPE-3	10.5			3/8	1/2		
FBP-3-1/2	FBPE-3-1/2	12.25	3/8	1/2					

# THERMOSTATIC EXPANSION VALVES

22, 407C, 410A

## Type ER – Knife Edge Joint Standard Cap Tube Length 60 inches (1.5 m)

Sporlan Type ER valve is a small brass bar body, externally adjustable with ODF solder connections, a replaceable thermostatic element, and balanced port construction. The ER valve is designed for R-22 and R-410A air conditioning and heat pump applications and is ideal for replacing I, BI, BBI and RI (non-RPB version only) valves.

R-22 and R-410A, and a large body style which extends capacities to 12 tons R-22 and 15 tons R-410A.

This valve may also be applied in bi-directional applications.



This valve type has two body styles: a small body which provides capacities up to 8 tons

### Specifications - element size no. 43 (R-22), no. 45 (R-410A), and no. 45-5, Knife Edge Joint

REFRIGERANT (Sporlan Code)	VALVE TYPE	NOMINAL CAPACITY kW of Refrigeration	ELEMENT SIZE NO.	THERMOSTATIC CHARGES AVAILABLE	STANDARD TUBING LENGTH in	CONNECTION – Inches <sup>1</sup> ODF Blue figures are standard and will be furnished unless otherwise specified.		NET WEIGHT – KG	SHIPPING WEIGHT – KG
						INLET	OUTLET		
<b>22 (V)</b> 407C (N) 407A (V) 422D (V)	ERVE-1	3.5	43	VGA VCP100	60 in. 1.5m	3/8	1/2	454g	680g
	ERVE-1-1/2	5.3					1/2 or 5/8		
	ERVE-2	7.0							
	ERVE-3	11							
	ERVE-4	14				5/8	7/8		
	ERVE-5	18							
	ERVE-6	21							
	ERVE-8	28							
	45-5	ERVE-10	35	ZGA ZCP180	60 in. 1.5m	3/8	1/2		
		ERVE-12	44				1/2 or 5/8		
		ERVE-1	3.5					3/8 or 1/2	1/2, 5/8 or 7/8
			ERVE-1-1/2				5.3		
<b>134a (J)</b> 409A (F)	ERZE-2	7.0	43	ZGA ZCP180	60 in. 1.5m	3/8	1/2	454g	680g
	ERZE-3	11					1/2 or 5/8		
	ERZE-4	14							
	ERZE-5	18							
	ERZE-6	21				5/8	7/8		
	ERZE-8	28							
	ERZE-10	35							
	ERZE-12	44							
	45-5	ERZE-1	3.5	ZGA ZCP180	60 in. 1.5m	3/8	1/2		
		ERZE-1-1/2	5.3				1/2 or 5/8		
		ERZE-1	3.5					3/8 or 1/2	1/2, 5/8 or 7/8
			ERZE-1-1/2				5.3		
ERZE-2	7.0	5/8	7/8						
	ERZE-3		11	1-1/8					

**Q** Valves are also available as special order with SAE connections.

Note: Valves with SAE inlet and outlet fittings are available only with the 1/4"SAE flare external equalizer; valves with ODF fittings are available only with the 1/4" ODF external equalizer.

Note: Valves can be supplied with internal equalizer on valves with nominal capacity of 2 or less.

# THERMOSTATIC EXPANSION VALVES

22, 410A

## Type ER with Number 43 and 45 Element

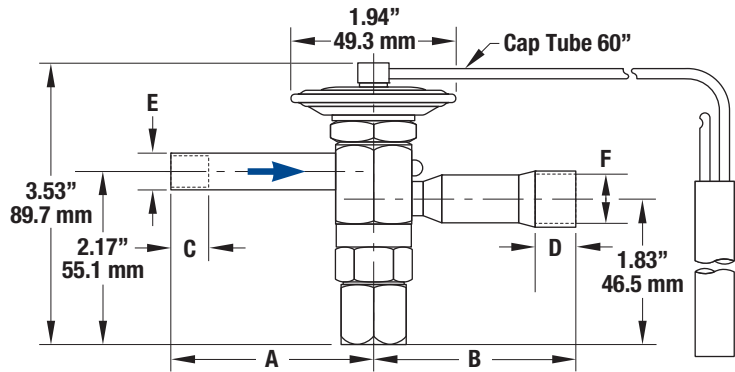
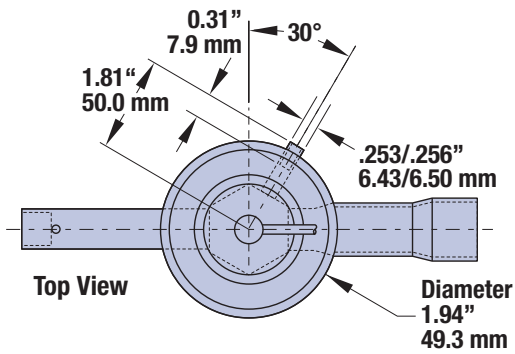

### Dimensions — Connections

REFRIGERANT	NOMINAL CAPACITY (tons)	FITTING SIZE		A	B	C	D	E	F
		INLET	OUTLET						
22 410A	1-1/2	3/8"	1/2"	61.5 mm	63.8 mm	7.9 mm	10.2 mm	9.58/9.68 mm	12.8/12.9 mm
	2								
	3								
	4								
	5								
	3	1/2"	5/8"	59.7 mm	63.8 mm	10.2 mm	12.7 mm	12.8/12.9 mm	15.9/16.1 mm
	4								
	5								
	4	5/8"	7/8"	59.7 mm	61.2 mm	12.7 mm	19.8 mm	15.9/16.1 mm	22.3/22.4 mm
	5								
	6								
	8								
6	5/8"	7/8"	59.7 mm	61.2 mm	12.7 mm	19.8 mm	15.9/16.1 mm	22.3/22.4 mm	
8									
8	5/8"	1-1/8"	59.7 mm	61.2 mm	12.7 mm	23.1 mm	15.9/16.1 mm	28.7/28.8 mm	
8									

### Bulb Sizes

STANDARD CHARGES	REFRIGERANT	
	22	410A
VCP100, ZCP180	12.7 mm x 76.2 mm	
GA	19.1 mm x 50.8 mm	

## Type ER with Number 45-5 Element

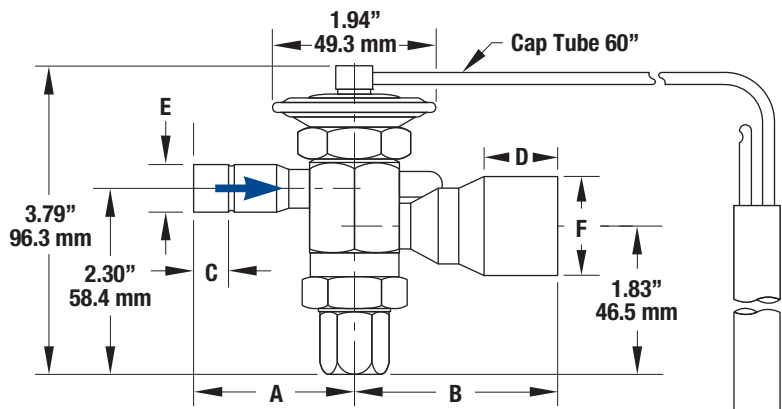
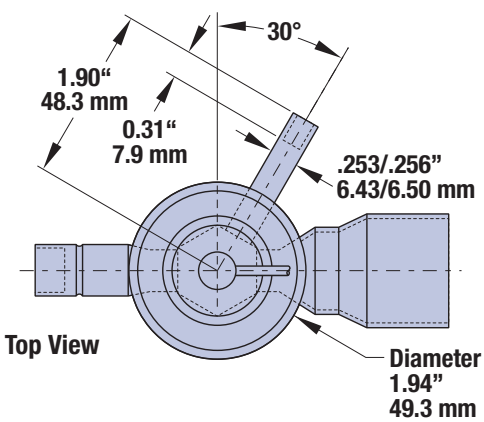

### Dimensions — Connections

REFRIGERANT	NOMINAL CAPACITY	FITTING SIZE		A	B	C	D	E	F
		INLET	OUTLET						
22	10 12	5/8"	7/8"	63.0 mm	63.8 mm	12.7 mm	19.8 mm	15.9/16.1 mm	22.3/22.4 mm
410A	12-1/2 15		1-1/8"				23.1 mm		28.7/28.8 mm



# THERMOSTATIC EXPANSION VALVES

22, 407C, 410A

## Type RCE – Knife Edge Joint Standard Cap Tube Length 30 inches (760 mm)



Type RC valves contain internal check valves to allow reverse flow on heat pump applications. This eliminates the need for an external check valve piped around the TEV for reverse flow. The RC valve can be used on Heat Pump and Air Conditioning (cooling only) applications.

Exact replacement valves for the CBI, CBBI, BI, and I valves are available from the OEM and should be ordered from the OEM during the warranty period of the equipment, or when special features such as specific bleed ports, connections, configurations, capillary tube lengths, etc. are required.

Replaceable elements available for these valves are the following: R-22, Element Kit Number KT-43-VGA-30", and R-410A, Element Kit Number KT-45-ZGA-30".

The Type RC thermostatic expansion valves are only available with the specifications shown below.

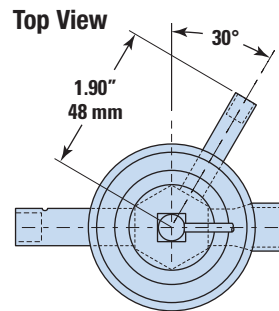
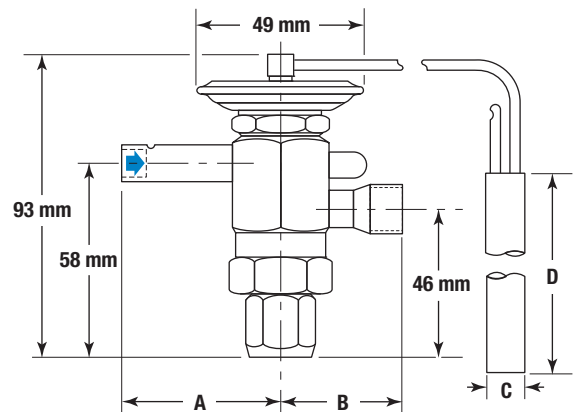

### Dimensions – Connections

VALVE TYPE	FITTING SIZE – Inches	mm	
		A	B
RCE-1, 1-1/2 & 2	3/8 ODF	48.8	36.8
	1/2 ODF	50.3	36.8
	5/8 ODF	—	38.9
RCE-3, 4, 5 & 6	3/8 ODF	48.8	36.8
	1/2 ODF	50.3	36.8
	5/8 ODF	—	38.9

### Bulb Sizes

THERMOSTATIC CHARGE	mm	
	C	D
NGA	19	51
NCP100	13	76
ZCP200	13	76
ZGA	19	51

\*1/2 ODF inlet available on 2 ton valves only.

### Specifications — Element Size No. 43 (No. 45 for R-410A), Knife Edge Joint

REFRIGERANT (Sporlan Code)	VALVE TYPE	EXTERNAL EQUALIZER 2 3	NOMINAL CAPACITY kW of Refrigeration	THERMOSTATIC CHARGES AVAILABLE	STANDARD TUBING LENGTH mm	CONNECTION – Inches <sup>1</sup> Blue figures are standard and will be furnished unless otherwise specified.		NET WEIGHT – kg	SHIPPING WEIGHT – kg
						INLET	OUTLET		
407C (N) 22 (V)	RCNE-1	1/4 SAE 1/4 ODF	3.5	CP100 GA	760	3/8	1/2	0.57	0.68
	RCNE-1-1/2		5.3						
	RCNE-2-GA		7.0						
	RCNE-3-GA		11						
	RCNE-4-GA		14						
	RCNE-5-GA		18						
RCNE-6-GA	21								
410A (Z)	RCZE-1	1/4 ODF	4.20	CP200 GA					
	RCZE-1-1/2		7.36						
	RCZE-2-GA		9.66						
	RCZE-3-GA		13.4						
	RCZE-4-GA		17.6						
	RCZE-5-GA		21.0						
RCZE-6-GA	25.2								

**Q** Valves are also available as special order with Chatleff connections.

**W** Valves with SAE inlet and outlet fittings are available only with the 1/4"SAE flare external equalizer; valves with ODF fittings are available only with the 1/4" ODF external equalizer.

**E** Valves with Chatleff fittings are available only with the 1/8" OD x 24" long tube with flare and nut external equalizer.

# THERMOSTATIC EXPANSION VALVES

22, 134a, 404A, 407C, 409A, 410A, 507

## Type Q and BQ

The Series Q and BQ are replaceable cartridge style thermostatic expansion valves, available in both conventional (Type Q) and balanced port (Type BQ) configurations. These valves can be supplied as a complete valve or as three component parts, body, cartridge, and thermostatic element. They are designed for small refrigeration systems, including refrigerated cases, coolers and freezers, and are also well suited for air conditioning and heat pump duty.

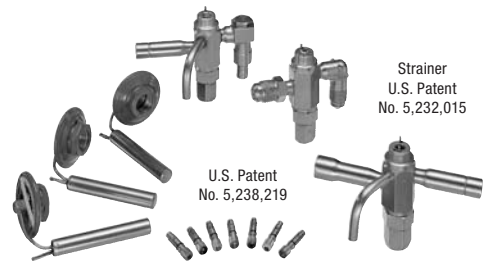

	NOMINAL CAPACITY (kW)					CARTRIDGE		
	R-22 R-407C	R-134a	R-404A R-507	R-409A	R-410A	SIZE	CARTRIDGE CODE	COLOR CODE
<b>SERIES Q</b>	0.88	0.44	0.44	0.44	—	0	QC-0	Red
	2.63	0.88	0.88	0.88	—	1	QC-1	Yellow
	3.5	1.75	1.75	1.75	—	2	QC-2	Green
	5.25	3.5	3.5	3.5	—	3	QC-3	Blue
	8.75	5.25	5.25	5.25	—	4	QC-4	Pink
	10.5	7	7	7	—	5	QC-5	Black
	17.5	10.5	10.5	10.5	—	6	QC-6	White
<b>SERIES BQ</b>	1.16	0.7	0.7	0.7	1.17	AAA	BQC-AAA	Red
	2.35	1.16	1.16	1.16	2.64	AA	BQC-AA	Yellow
	5.25	3.5	3.5	3.5	6.15	A	BQC-A	Blue
	10.5	6.13	6.13	6.13	12.3	B	BQC-B	Pink
	19.25	10.5	10.5	10.5	21.1	C	BQC-C	White

Q valve not suitable for R-410A. BQ valve cartridges are available with 15% bleed port.

## Q – Valve Nomenclature/Ordering Instructions

QE	O	(1/3T)	V	C	3/8"	X	1/2"	X	1/4"	X	5'
Valve Type Q, EQ, SQ = Internally Equalized  QE, EQE, SQE = Externally Equalized	Cartridge Size	Nominal Capacity (Tons)	Refrigerant Code	Thermostatic Charge	Inlet Connection Size		Outlet Connection Size		External Equalizer Connection Size		Capillary Tubing Length  Inches or Feet

## BQ – Valve Nomenclature/Ordering Instructions

BQE	AAA	V	C	3/8"	X	1/2"	X	1/4"	X	5'
Valve Type BQ, EBQ, SBQ = Internally Equalized  BQE, EBQE, SBQE = Externally Equalized	Cartridge Size	Refrigerant Code	Thermostatic Charge	Inlet Connection Size		Outlet Connection Size		External Equalizer Connection Size		Capillary Tubing Length  Inches or Feet

# THERMOSTATIC EXPANSION VALVES

## Selecting Body Type

### Q/BQ

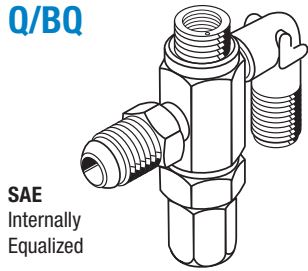

SAE Internally Equalized

### QE/BQE

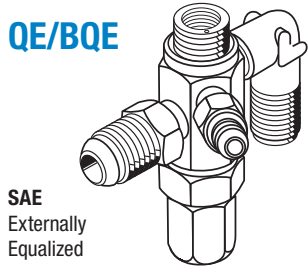

SAE Externally Equalized

### EQ/EBQ

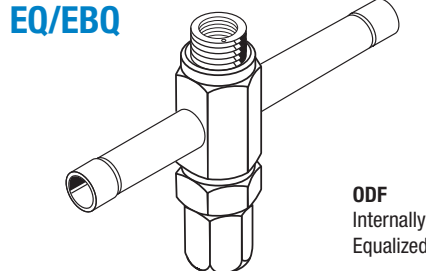

ODF Internally Equalized

### EQE/EBQE

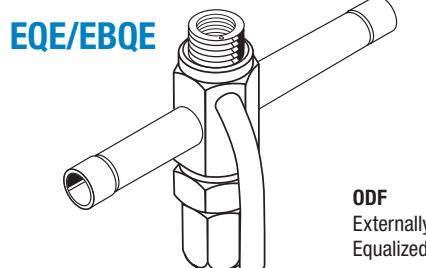

ODF Externally Equalized

### SQ/SBQ

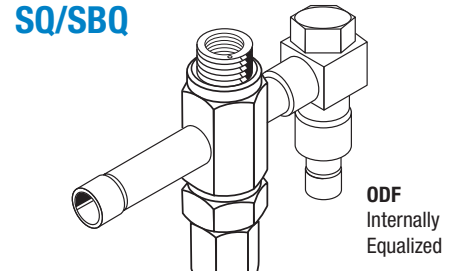

ODF Internally Equalized

### SQE/SBQE

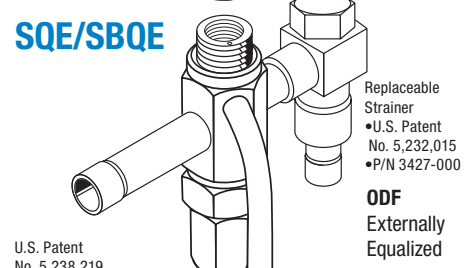

Replaceable Strainer  
•U.S. Patent No. 5,232,015  
•P/N 3427-000  
ODF Externally Equalized

U.S. Patent No. 5,238,219

Q/BQ & QE/BQE Options
Inlet x Outlet

1/4 x 3/8 SAE, 90° Angle Inlet  
1/4 x 1/2 SAE, 90° Angle Inlet  
3/8 x 1/2 SAE, 90° Angle Inlet

EQ & EBQ Options	EQE & EBQE Options
Inlet x Outlet	Inlet x Outlet

3/8 x 1/2 ODF, Straight Thru  
3/8 x 1/2 ODF, 90° Angle Inlet

3/8 x 1/2 ODF, Straight Thru  
3/8 x 5/8 ODF, Straight Thru  
1/2 x 5/8 ODF, Straight Thru  
1/2 x 7/8 ODF, Straight Thru  
3/8 x 1/2 ODF, 90° Angle Inlet

SQ/SBQ & SQE/SBQE Options
Inlet x Outlet

3/8 x 1/2 SAE, 90° Angle Inlet

## Selecting The Element

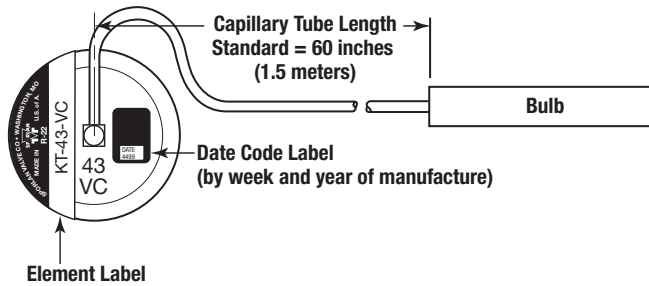

KT	43	V	C
Abbreviation for "Kit"	Element Size Number	*Refrigerant Code	Thermostatic Charge

See page 3 for thermostatic charges available. BQ valves for R-410A, use KT-45 element.

## Selecting The Cartridge — See table on previous page for cartridge codes.

### Q Valve Cartridge Service Kit — Part No. 184000

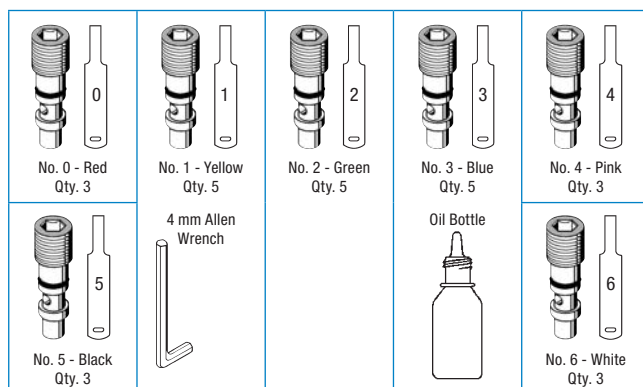

### BQ Valve Cartridge Service Kit — Part No. 184007

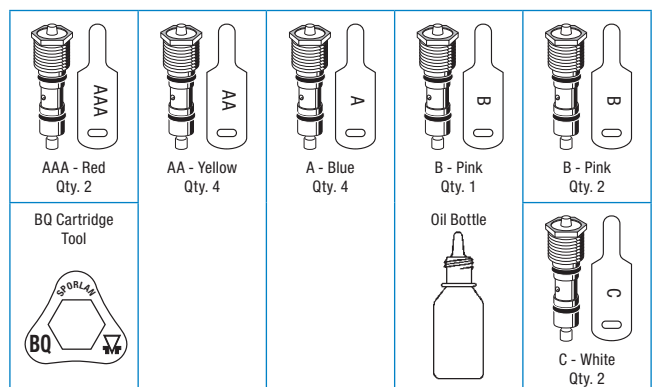

# THERMOSTATIC EXPANSION VALVES

## Type Q, QE, BQ, & BQE

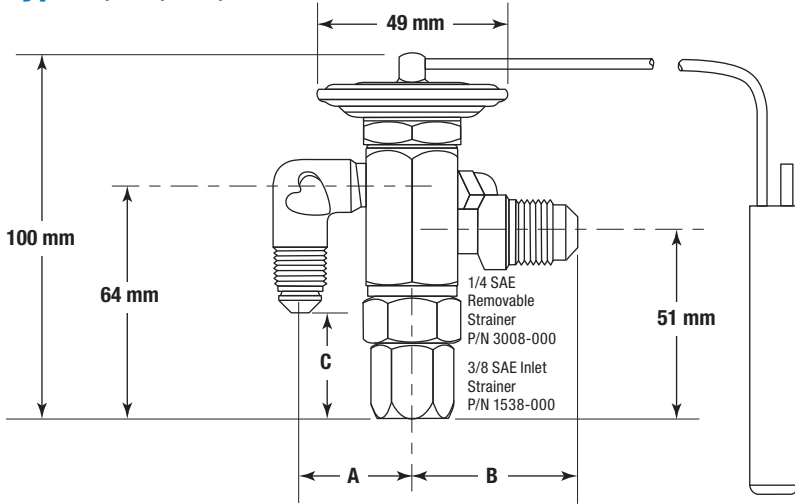

## Dimensions – Connections

FITTING SIZE Inches	mm		
	A	B	C
1/4 SAE, 90° Angle	30	—	37
3/8 SAE, 90° Angle	34	—	27
3/8 SAE	—	41	—
1/2 SAE	—	46	—

Top View

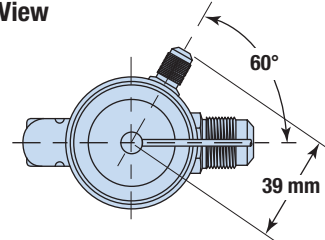

## Type EQ, EQE, EBQ, & EBQE

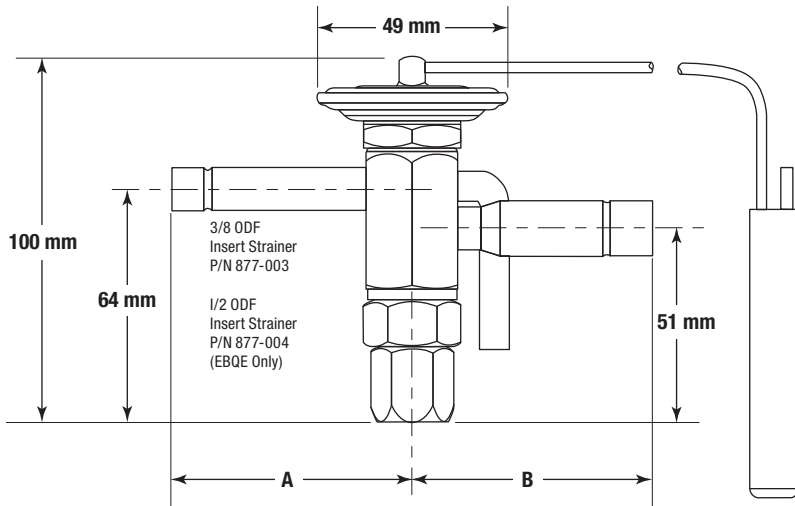

## Dimensions – Connections

FITTING SIZE Inches	mm	
	A	B
3/8	64	—
1/2	61	63
5/8	—	63
7/8	—	61

Top View

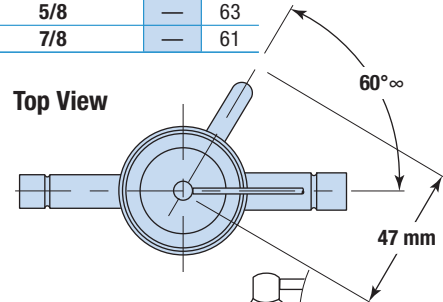

View of 90°  
elbow inlet

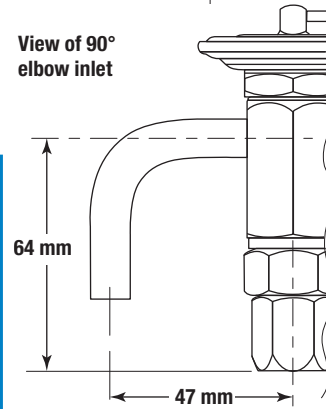

## Type SQ, SQE, SBQ, & SBQE

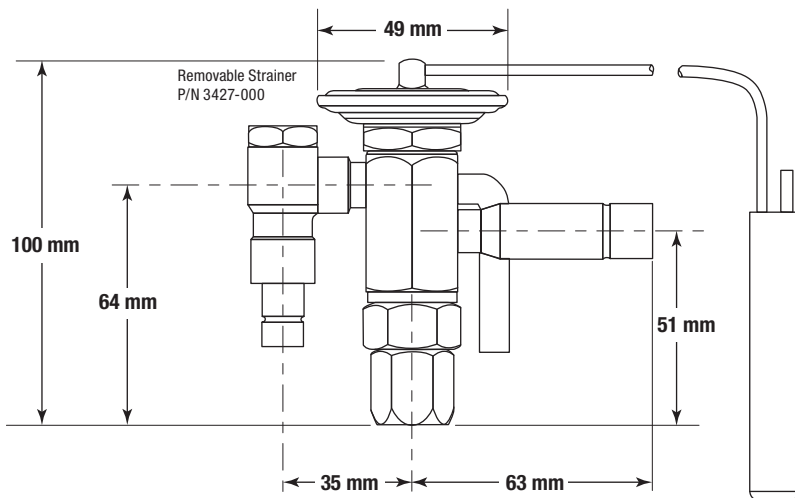

Top View

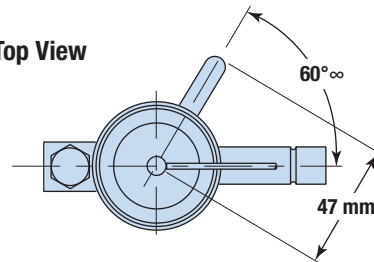

## Series Q & BQ Bulb Sizes – mm

STANDARD CHARGES	REFRIGERANT			
	22	134a	404A	507
C			13 OD x 76	
Z & ZP	13 OD x 76	—		13OD x 76
CP			13 OD x 76	
VGA	19 OD x 51			—

# THERMOSTATIC EXPANSION VALVES

22, 134a, 404A, 507

## Type S

Standard Cap Tube Length 60 inches (1.5 m)

Sporlan Type S valve is a brass bar body, externally adjustable valve with ODF solder connections. The thermostatic element is replaceable, and the inlet connection has a permanent 12 mesh strainer. This valve is designed for both air conditioning and refrigeration applications.

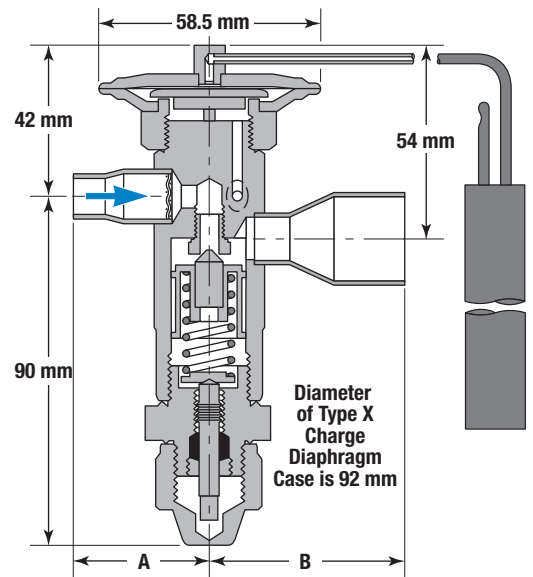

### Dimensions – Connections

VALVE TYPE	FITTING SIZE Inches	mm	
		A	B
S	3/8 ODF	34	—
	1/2 ODF	33	34.5
	5/8 ODF	38	40
	7/8 ODF	—	54
	1-1/8 ODF	—	55.5

### Bulb Sizes

STANDARD CHARGES	REFRIGERANT			
	22	134a	404A	507
C	13 OD x 89			
Z & ZP Series	13 OD x 89	—	13 OD x 89	—
X	19 OD x 102	—	19 OD x 102	—
CP Series	13 OD x 89			—
VGA	19 OD x 51	—	—	—

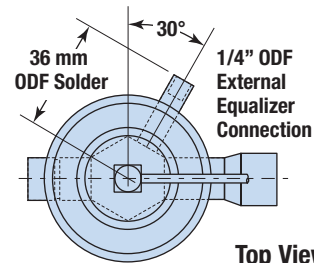

### Specifications — Element Size No. 83, Knife Edge Joint

REFRIGERANT (Sporlan Code)	VALVE TYPE		NOMINAL CAPACITY kW of Refrigeration	THERMOSTATIC CHARGES AVAILABLE	STANDARD TUBING LENGTH m	CONNECTIONS - Inches W ODF Solder Blue figures are standard and will be furnished unless otherwise specified.		NET WEIGHT - kg	SHIPPING WEIGHT - kg
	INTERNAL EQUALIZER Q	EXTERNAL EQUALIZER				INLET	OUTLET		
407C (N) 22 (V)	SN-2	SNE-2	7.0	Refer to Recommended Thermostatic Charges on page 3	1.5	3/8 or 1/2	5/8, 7/8 or 1-1/8	0.9	1.4
	SN-3	SNE-3	11			1/2	5/8, 7/8 or 1-1/8		
	SN-4	SNE-4	14			5/8	7/8 or 1-1/8		
	SN-5	SNE-5	18			7/8	1-1/8		
	—	SNE-8	28			3/8 or 1/2	5/8, 7/8 or 1-1/8		
	—	SNE-10	35			1/2	5/8, 7/8 or 1-1/8		
—	SNE-15	56.5	5/8			7/8 or 1-1/8			
134a (J) 409A (F)	SJ-2	SJE-2	7.0			7/8	1-1/8		
	SJ-2-1/2	SJE-2-1/2	8.8			3/8 or 1/2	5/8, 7/8 or 1-1/8		
	SJ-3	SJE-3	11			1/2	5/8, 7/8 or 1-1/8		
	—	SJE-5	18			5/8	7/8 or 1-1/8		
	—	SJE-6	21			7/8	1-1/8		
	—	SJE-10	35			3/8 or 1/2	5/8, 7/8 or 1-1/8		
404A (S)	SS-2	SSE-2	7.0			1/2	5/8, 7/8 or 1-1/8		
	SS-3	SSE-3	11			5/8	7/8 or 1-1/8		
	SS-4	SSE-4	14			7/8	1-1/8		
	—	SSE-6	21			3/8 or 1/2	5/8, 7/8 or 1-1/8		
	—	SSE-7	25			1/2	5/8, 7/8 or 1-1/8		
	—	SSE-10	35	5/8	7/8 or 1-1/8				
507 (P)	SP-2	SPE-2	7.0	7/8	1-1/8				
	SP-3	SPE-3	11	3/8 or 1/2	5/8, 7/8 or 1-1/8				
	SP-4	SPE-4	14	1/2	5/8, 7/8 or 1-1/8				
	—	SPE-6	21	5/8	7/8 or 1-1/8				
	—	SPE-7	25	7/8	1-1/8				
	—	SPE-10	35	3/8 or 1/2	5/8, 7/8 or 1-1/8				

Q Valves listed in this column NOT AVAILABLE with MOP Type air conditioning charges.

W ODF Solder indicates a female connection on the valve of proper diameter to receive copper tubing of corresponding OD size. Thus 5/8" ODF will receive 5/8" OD tubing.

Note: S Valves not available for R-410A.

# THERMOSTATIC EXPANSION VALVES

22, 134a, 404A, 407C, 409A, 507

## Type EBS

Standard Cap Tube Length 60 inches (1.5 m)

Sporlan Type EBS valve is a brass bar body valve having the same physical size as the Type S valve except the Type EBS features a balanced port construction and extended ODF connections. The thermostatic element is replaceable. The balanced port construction makes this valve ideally suited for refrigeration and air conditioning applications which operate over widely varying conditions.

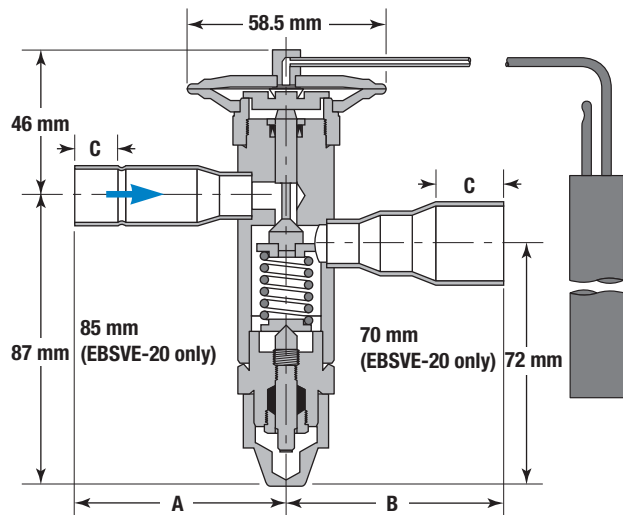

### Dimensions — Connections

VALVE TYPE	FITTING SIZE Inches	mm		
		A	B	C
EBS	3/8 ODF	62	—	9
	1/2 ODF	62	—	13
	5/8 ODF	62	64	19
	7/8 ODF	—	64	20.5
	1-1/8 ODF	—	77	24.5

### Bulb Sizes

STANDARD CHARGES	REFRIGERANT			
	22	134a	404A	507
C	13 OD x 89			
Z & ZP Series	13 OD x 89	—	13 OD x 89	
CP Series	13 OD x 89			—
VGA	19 OD x 51	—	—	—

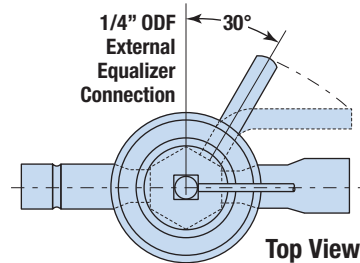

### Specifications — Element Size No. 83, Knife Edge Joint

REFRIGERANT (Sporlan Code)	VALVE TYPE	NOMINAL CAPACITY kW of Refrigeration	THERMOSTATIC CHARGES AVAILABLE	STANDARD TUBING LENGTH m	CONNECTIONS - Inches			NET WEIGHT - kg	SHIPPING WEIGHT - kg
	EXTERNAL EQUALIZER				INLET	OUTLET	EXTERNAL EQUALIZER		
<b>407C (N)</b> 22 (V)	EBSNE-8	28	*Refer to Recommended Thermostatic Charges on page 3	1.5	1/2 or <b>5/8</b>	<b>7/8</b> or 1-1/8	1/4 Pointed Toward Bottom Cap or Parallel to Outlet Connection	0.9	1.4
	EBSNE-11	39			1/2, <b>5/8</b> or 7/8	<b>7/8</b> , 1-1/8 or 1-3/8			
	EBSNE-15	53			5/8 or <b>7/8</b>	<b>7/8</b> , <b>1-1/8</b> or 1-3/8			
	EBSNE-20	70			<b>7/8</b>	1-1/8 or <b>1-3/8</b>			
<b>134a (J)</b> 409A (F)	EBSJE-5	18			1/2 or <b>5/8</b>	<b>7/8</b> or 1-1/8			
	EBSJE-7	25			1/2, <b>5/8</b> or 7/8	<b>7/8</b> , 1-1/8 or 1-3/8			
	EBSJE-9	32			5/8 or <b>7/8</b>	<b>7/8</b> , <b>1-1/8</b> or 1-3/8			
	EBSJE-12	42			<b>7/8</b>	1-1/8 or <b>1-3/8</b>			
<b>404A (S)</b>	EBSSE-6	21			1/2 or <b>5/8</b>	<b>7/8</b> or 1-1/8			
	EBSSE-7-1/2	26			1/2, <b>5/8</b> or 7/8	<b>7/8</b> , 1-1/8 or 1-3/8			
	EBSSE-10	35			5/8 or <b>7/8</b>	<b>7/8</b> , <b>1-1/8</b> or 1-3/8			
	EBSSE-13	46			<b>7/8</b>	1-1/8 or <b>1-3/8</b>			
<b>507 (P)</b>	EBSPE-6	21			1/2 or <b>5/8</b>	<b>7/8</b> or 1-1/8			
	EBSPE-7-1/2	26			1/2, <b>5/8</b> or 7/8	<b>7/8</b> , 1-1/8 or 1-3/8			
	EBSPE-10	35			5/8 or <b>7/8</b>	<b>7/8</b> , <b>1-1/8</b> or 1-3/8			
	EBSPE-13	46			<b>7/8</b>	1-1/8 or <b>1-3/8</b>			

Q ODF Solder indicates a female connection on the valve of proper diameter to receive copper tubing of corresponding OD size. Thus 5/8" ODF will receive 5/8" OD tubing.

\* X charge not available.

Note: Not suitable for bi-directional flow control.



# THERMOSTATIC EXPANSION VALVES

22, 134a, 404A, 407C, 409A, 410A, 507

## Type O

Standard Cap Tube Length 60 inches (1.5 m)

Sporlan Type O valve is a brass bar body, externally adjustable valve with ODF solder connections. The thermostatic element is replaceable, and the inlet connection has a permanent 12 mesh strainer. This valve type features a balanced port construction, and it is designed for both air conditioning and refrigeration applications. A synthetic seating surface provides tight shut-off during system off periods.

This valve type has two body styles: a small body which provides capacities up to 133 kW R-407C, and a large body which extends capacities to 315 kW R-407C.

The valve can also be ordered as a bi-directional valve, allowing control of flow in both directions for use on heat pump applications.

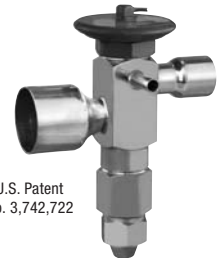

U.S. Patent No. 3,742,722

## Specifications — Element Size No. 83, No. 33, No. 85 (R-410A), and No. 85-3 (R-410A), Knife Edge Joint

REFRIGERANT (Sporlan Code)	VALVE TYPE	NOMINAL CAPACITY kW of Refrigeration	THERMOSTATIC ELEMENT SIZE NO.	THERMOSTATIC CHARGES AVAILABLE	STANDARD TUBING LENGTH m	CONNECTIONS - Inches 2 ODF Solder		NET WEIGHT - kg	SHIPPING WEIGHT - kg		
	Q EXTERNAL EQUALIZER					Blue figures are standard and will be furnished unless otherwise specified.					
						INLET	OUTLET				
134a (J) 409A (F)	OJE-12	42	83	*Refer to Recommended Thermostatic Charges on page 3	1.5	7/8	1-1/8	0.9	1.4		
	OJE-16	56					1-3/8				
	OJE-23	81	33			1-1/8	1-3/8 or 1-5/8	1.8	2.3		
	OJE-32	112									
	OJE-38	133									
404A (S) 507 (P)	OJE-40	140									
	OSE-12	42	83			*Refer to Recommended Thermostatic Charges on page 3	1.5	7/8	1-1/8	0.9	1.4
	OSE-21	74							1-3/8		
	OSE-30	105	33					1-1/8	1-3/8 or 1-5/8	1.8	2.3
	OSE-35	123									
OSE-38	133										
407C (N) 22 (V)	OSE-45	158									
	ONE-20	70	83	*Refer to Recommended Thermostatic Charges on page 3	1.5			7/8	1-1/8	0.9	1.4
	ONE-30	105							1-3/8		
	ONE-38	133	33-8					1-1/8	1-3/8 or 1-5/8	1.8	2.3
	ONE-40	140									
ONE-55	193	33									
ONE-70	215										
410A (Z)	ONE-90	315	63-3								
	OZE-20	70	85			*Refer to Recommended Thermostatic Charges on page 3	1.5	7/8	1-1/8	0.9	1.4
	OZE-25	84							1-3/8		
	OZE-35	116	85-3					1-1/8	1-3/8 or 1-5/8	1.8	2.3
	OZE-50	175									
OZE-60	210										

Q Standard External Equalizer Connection 1/4" ODF Solder, 1/4" SAE flare connection available on request.

2 ODF Solder indicates a female connection on the valve of proper diameter to receive copper tubing of corresponding OD size. Thus 5/8" ODF will receive 5/8" OD tubing.

\* X charge not available.

## O – Valve Nomenclature/Ordering Instructions

O	V	E	B	20	GA	X	7/8"	X	1-3/8"	X	1/4"	X	5'
Valve Type	Refrigerant Code	External Equalizer	Optional Bi-Directional Feature	Nominal Capacity	Thermostatic Charge		Inlet Connection Size		Outlet Connection Size		External Equalizer Connection Size		Capillary Tubing Length Inches or Feet

# THERMOSTATIC EXPANSION VALVES

22, 134a, 404A, 410A, 507

## Type 0 with Number 83 or 85 Element

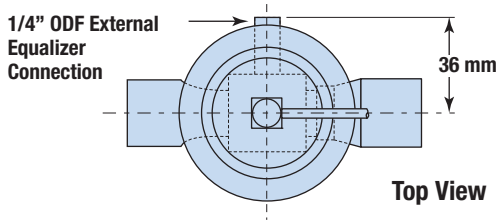

### Dimensions — Connections

VALVE TYPE	FITTING SIZE Inches	mm		
		A	B	C
0	7/8 ODF	53	—	19
	1-1/8 ODF	56	57	25
	1-3/8 ODF	—	61	25

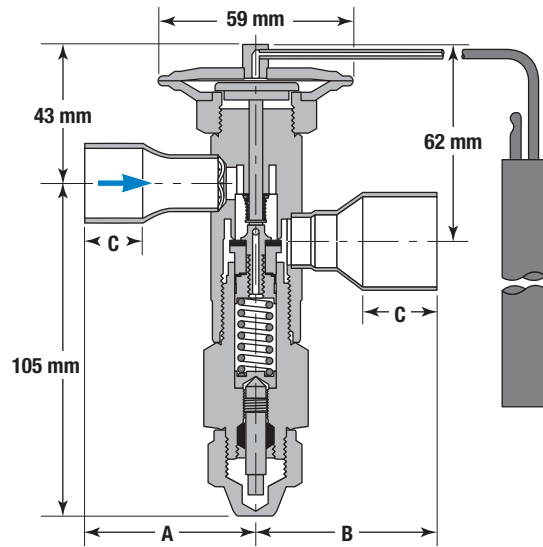

### Bulb Sizes

STANDARD CHARGES	REFRIGERANT				
	22	134a	404A	410A	507
C	—	13 OD x 89	—	—	13 OD x 89
Z & ZP Series	13 OD x 89	—	13 OD x 89	—	13 OD x 89
CP Series	—	13 OD x 89	—	—	—
VGA	19 OD x 51	—	—	—	—
ZGA	—	—	—	19 OD x 51	—

## Type 0 with Number 33 or 85-3 Element

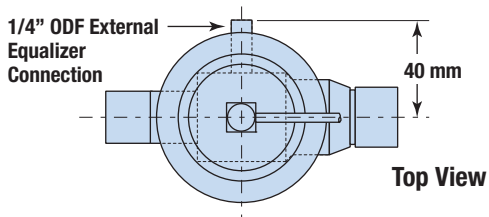

### Dimensions — Connections

VALVE TYPE	FITTING SIZE Inches	mm		
		A	B	C
0	1-1/8 ODF	68	—	23
	1-3/8 ODF	—	76	25
	1-5/8 ODF	—	79	28

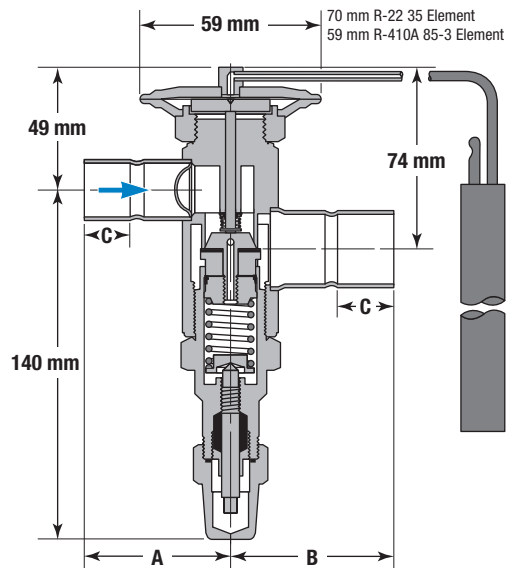

### Bulb Sizes

STANDARD CHARGES	REFRIGERANT				
	22	134a	404A	410A	507
C	19 OD x 102	13 OD x 127	19 OD x 102	—	19 OD x 102
Z & ZP Series	19 OD x 102	—	19 OD x 102	—	19 OD x 102
CP Series	—	19 OD x 102	—	—	—
VGA	19 OD x 102	—	—	—	—
ZGA	—	—	—	19 OD x 51	—

# THERMOSTATIC EXPANSION VALVES

22, 134a, 404A, 407C, 409A, 507

## Type H

Brass bar body, externally adjustable valve with flange connections. Inlet flange bushing has a permanent 16 mesh strainer. The FPT flange connection requires the K-1178 adapter kit. This valve provides the smallest capacity TEVs with flange connections and it is suitable for both air conditioning and refrigeration applications.

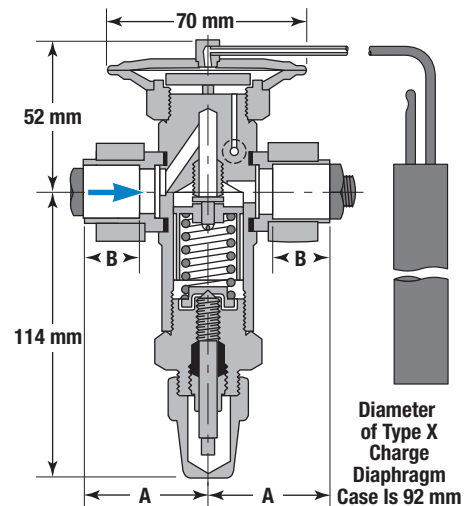

## Dimensions – Connections

VALVE TYPE	SOLDERING BUSHING	mm	
		A	B
H	1/2	51	22
	5/8	51	22
	7/8	51	22
	1-1/8	52	24

## Bulb Sizes

STANDARD CHARGES	REFRIGERANT			
	22	134a	404A	507
C	19 OD x 102	13 OD x 127	19 OD x 102	
Z & ZP Series	19 OD x 102	—	19 OD x 102	
X	19 OD x 102	—	19 OD x 102	
CP Series		19 OD x 102		—
VGA	19 OD x 102	—	—	—

**Specifications** — Element Size No. 33, Gasket Joint, Standard Tubing Length 1.5 Meters, Flange Ring Size – 1-1/4" OD x 1" ID.

REFRIGERANT (Sporlan Code)	TYPE & CAPACITY		THERMOSTATIC CHARGES AVAILABLE	STANDARD CONNECTIONS Inches ROLF SOLDER FLANGE	
	WINTERNAL EQUALIZER	EEXTERNAL EQUALIZER		Blue figures are standard and will be furnished unless otherwise specified.	
				INLET	OUTLET
<b>134a (J)</b> 409A (F)	HJ-1-1/2	HJE-1-1/2	Refer to Recommended Thermostatic Charges on Page 3	1/2	5/8
	HJ-3	HJE-3		5/8	7/8
	HJ-4	HJE-4			
	HJ-5	HJE-5			
	—	HJE-8			
—	HJE-12	7/8		1-1/8	
<b>404A (S)</b> 507 (P)	HS-1-1/2	HSE-1-1/2		1/2	5/8
	HS-3	HSE-3		5/8	7/8
	HS-4	HSE-4			
	—	HSE-6-1/2			
	—	HSE-9			
	—	HSE-12		7/8	1-1/8
<b>407C (N)</b> 22 (V)	HN-2-1/2	HVE-2-1/2		1/2	5/8
	HN-5-1/2	HVE-5-1/2		5/8	7/8
	—	HVE-7			
	—	HVE-11			
	—	HVE-16			
	—	HVE-20	7/8	1-1/8	

**Q** Connections shown are most readily available. Connections shown in Bulletin 10-10 are also available on special order.  
**W** Valves listed in this column NOT AVAILABLE with MOP Type air conditioning charges.  
**E** Standard External Equalizer Connection 1/4" SAE Flare, 1/4" ODF Solder connection available on request.  
**R** ODF Solder indicates a female connection on the valve of proper diameter to receive copper tubing of corresponding OD size. Thus 1/2" ODF will receive 1/2" OD tubing.  
**5** Tubing lengths other than standard available upon special order at an additional cost.  
 NOTE: The H valve is not available for R-410A.  
 External Equalizer Connection is required whenever valves are used with Sporlan Refrigerant Distributors.

# THERMOSTATIC EXPANSION VALVES

22, 134a, 404A, 407C, 409A, 507

## Type M

Cast bronze body, externally adjustable valve with flange connections. Inlet has a 12 mesh strainer. This valve type provides valve capacities greater than the Type H and it is suitable for air conditioning and refrigeration applications. Flanges for the Type M valve are interchangeable with the Type V valve.

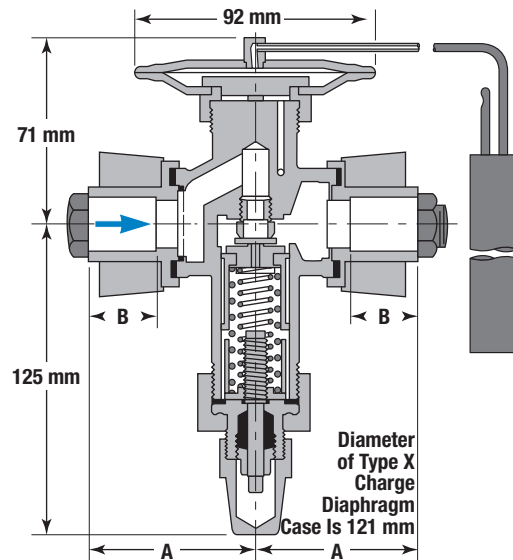

## Dimensions — Connections

VALVE TYPE	SOLDERING BUSHING	mm	
		A	B
H	7/8	60	22
	1-1/8	70	24
	1-3/8	70	24
	1-5/8	82	31

## Bulb Sizes

STANDARD CHARGES	REFRIGERANT			
	22	134a	404A	507
C	22 OD x 152			
Z & ZP Series	22 OD x 152	—	22 OD x 152	
X	22 OD x 152	—	22 OD x 152	
CP Series	19 OD x 102			—
VGA	19 OD x 102	—	—	—

**Specifications** — Element Size No. 63, Gasket Joint, Standard Tubing Length 1.5 Meters<sup>4</sup>  
Flange Ring Size — 1-3/4" OD x 1-1/4" ID.

REFRIGERANT (Sporlan Code)	TYPE & CAPACITY	THERMOSTATIC CHARGES AVAILABLE	STANDARD CONNECTIONS Inches 30DF SOLDER FLANGE Blue figures are standard and will be furnished unless otherwise specified.		
	EXTERNAL EQUALIZER		INLET	OUTLET	
<b>134a (J)</b> 409A (F)	MJE-15	Refer to Recommended Thermostatic Charges on Page 3	7/8	1-1/8	
	MJE-20		1-1/8		
	MJE-25		7/8		
<b>404A (S)</b> 507 (P)	MSE-15		1-1/8		
	MSE-20		7/8		
	MSE-25		1-1/8		
<b>407C (N)</b> 22 (V)	MSE-30		7/8		
	MNE-21		1-1/8		
	MNE-26		7/8		
	MNE-34		1-1/8		
	MNE-42				

**Q** Connections shown are most readily available. Connections shown in Bulletin 10-10 are also available on special order.  
**2** Standard External Equalizer Connection 1/4" SAE Flare, 1/4" ODF Solder connection available on request.  
**3** ODF Solder indicates a female connection on the valve of proper diameter to receive copper tubing of corresponding OD size. Thus 1/2" ODF will receive 1/2" OD tubing.  
**4** Tubing lengths other than standard available upon special order at an additional cost.  
 NOTE: The M valve is not available for R-410A.  
 External Equalizer Connection is required whenever valves are used with Sporlan Refrigerant Distributors.

# COMBINATION THERMOSTATIC VALVES

22, 134a, 404A, 407C, 409A, 507

## Type V

Cast bronze body, externally adjustable valve with flange connections. Inlet has a 12 mesh strainer. This valve type features a dual port semi-balanced design. This valve type provides valve capacities greater than the Type M and is suitable for air conditioning and refrigeration applications. Flanges for the Type V are interchangeable with the Type M.

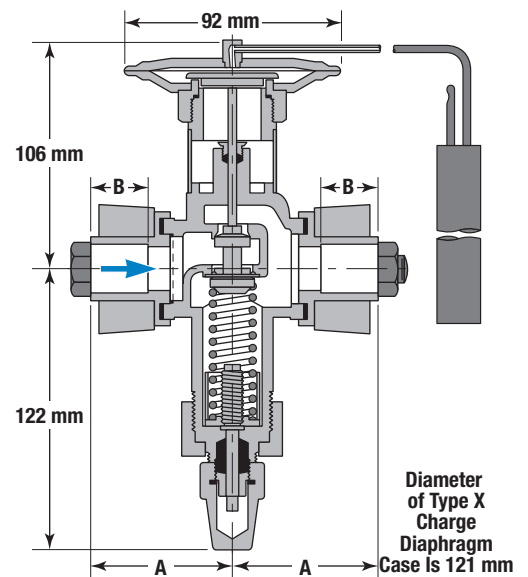

## Dimensions — Connections

VALVE TYPE	SOLDERING BUSHING	mm	
		A	B
V	7/8	60	22
	1-1/8	70	24
	1-3/8	70	24
	1-5/8	82	31

## Bulb Sizes

STANDARD CHARGES	REFRIGERANT			
	22	134a	404A	507
G	22 OD x 152			
Z & ZP Series	22 OD x 152	—	22 OD x 152	—
X	22 OD x 152	—	22 OD x 152	—
CP Series	19 OD x 102			—
VGA	19 OD x 102	—	—	—

**Specifications** — Element Size No. 63,  
Gasket Joint, Standard Tubing Length 1.5 Meters<sup>4</sup>  
Flange Ring Size — 1-3/4" OD x 1-1/2" ID.

REFRIGERANT (Sporlan Code)	TYPE & CAPACITY	THERMOSTATIC CHARGE AVAILABLE	STANDARD CONNECTION Inches 30DF SOLDER FLANGE	
	EXTERNAL EQUALIZER		INLET	OUTLET
134a (J) 409A (F)	VJE-35	Refer to Recommended Thermostatic Charges on Page 3	1-3/8	1-3/8
	VJE-45			
	VJE-55			
404A (S) 507 (P)	VSE-38			
	VSE-50			
	VSE-70			
407C (N) 22 (V)	VNE-52			
	VNE-70			
	VNE-100			

**Q** Connections shown are most readily available. Connections shown in Bulletin 10-10 are also available on special order.  
**2** Standard External Equalizer Connection 1/4" SAE Flare, 1/4" ODF Solder connection available on request.  
**3** ODF Solder indicates a female connection on the valve of proper diameter to receive copper tubing of corresponding OD size. Thus 1/2" ODF will receive 1/2" OD tubing.  
**4** Tubing lengths other than standard available upon special order at an additional cost.  
 NOTE: The V valve is not available for R-410A.  
 External Equalizer Connection is required whenever valves are used with Sporlan Refrigerant Distributors.

# THERMOSTATIC EXPANSION VALVES

22, 134a, 407C, 409A

## Type W

Cast bronze body, externally adjustable valve with flange connections. Inlet has a 12 mesh strainer. This valve type features a dual port semi-balanced design and it is primarily for large capacity chillers. This valve type provides the largest valve capacities available for flange connection TEVs.

## Dimensions — Connections

VALVE TYPE	FITTING SIZE	mm					
		A	B	C	D	E	F
W	1-1/8	28	32	27	23	40	78
	1-3/8	35	39	33	25	41	80
	1-5/8	41	45	38	28	44	83
	2-1/8	54	62	49	34	39	83

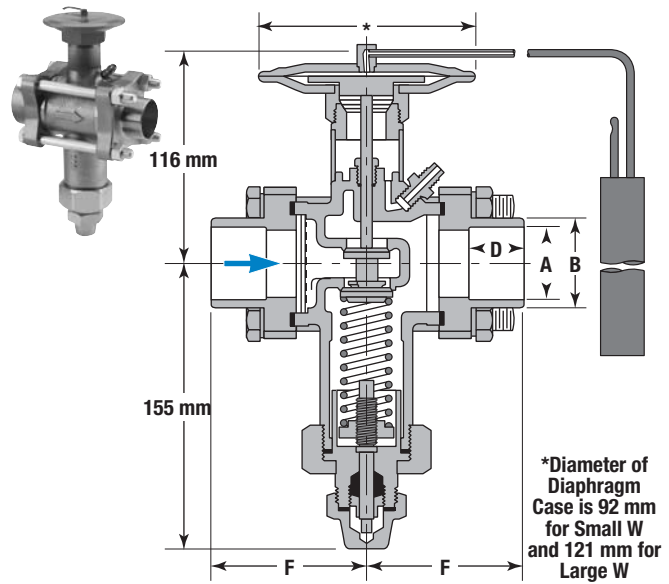

## Bulb Sizes

STANDARD CHARGES	REFRIGERANT		
	ELEMENT SIZE NUMBER	22	134a
C	63	22 OD x 152	
Z & ZP Series		22 OD x 152	—
X		22 OD x 152	—
CP Series		19 OD x 102	
VGA	7	19 OD x 102	—
G		19 OD x 102	—

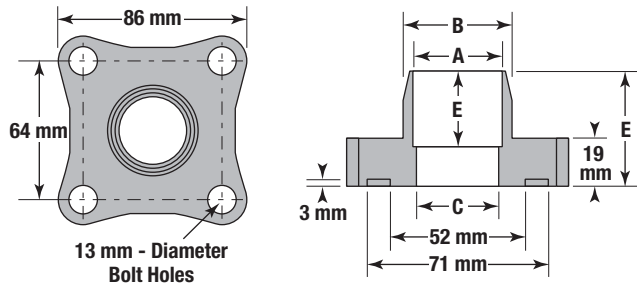

**Specifications** — Element Size No. 63, Small Capacity No. 7 Large Capacity — Gasket Joint, Standard Tubing Length 3 Meters  
 Flange Ring Size — 2-3/4" OD x 2-3/16" ID.

REFRIGERANT (Sporlan Code)	TYPE & CAPACITY	ELEMENT SIZE NUMBER	THERMOSTATIC CHARGES AVAILABLE	QSTANDARD CONNECTIONS Inches 30DF SOLDER FLANGE	
	2EXTERNAL EQUALIZER			INLET	OUTLET
134a (J) 409A (F)	WJE-80	63	4	1-5/8	2-1/8
	WJE-110	7	G only		
407C (N) 22 (V)	WNE-135	63	4		
	WNE-180	7	G only		

Q Connections shown are most readily available. Connections shown in Bulletin 10-10 are also available on special order.  
 2 Standard External Equalizer Connection 1/4" SAE Flare, 1/4" ODF Solder connection available on request.  
 3 ODF Solder indicates a female connection on the valve of proper diameter to receive copper tubing of corresponding OD size. Thus 1/2" ODF will receive 1/2" OD tubing.  
 4 Refer to Recommended Thermostatic Charges, Page 3.  
 5 Tubing lengths other than standard available upon special order at an additional cost.  
 NOTE: The W valve is not available for R-410A.  
 External Equalizer Connection is required whenever valves are used with Sporlan Refrigerant Distributors.



# THERMOSTATIC EXPANSION VALVES

134a, 409A

## Air Conditioning, Heat Pump and Commercial Refrigeration Applications

VALVE TYPES	NOMINAL CAPACITY	NOMINAL CAPACITY	REFRIGERANT					
			134a			409A		
			RECOMMENDED THERMOSTATIC CHARGE					
			JC, JCP60			FC, FCP60		
			EVAPORATOR TEMPERATURE °C					
ton	kW	5°	-5°	-15°	5°	-5°	-15°	
FB	1/8	0.44	0.76	0.89	0.80	0.76	0.90	0.81
FB	1/4	0.88	1.51	1.77	1.59	1.52	1.80	1.62
FB	1/2	1.8	2.85	3.35	3.01	2.87	3.39	3.06
FB	1	3.5	4.80	5.64	5.07	4.83	5.71	5.15
FB	1-1/2	5.3	5.97	7.01	6.30	6.01	7.10	6.41
FB-S	2	7.0	8.17	8.73	8.01	8.23	8.84	8.15
FB-S	2-1/2	8.8	10.2	10.9	10.0	10.3	11.0	10.2
S	3	11	12.3	13.1	12.0	12.3	13.3	12.2
S	5	18	20.6	18.8	15.6	20.7	19.0	15.8
S	6	21	24.7	22.5	18.7	24.9	22.8	19.0
S	10	35	38.2	36.3	31.1	38.4	36.7	31.7
H	1-1/2	5.3	6.54	6.99	6.40	6.58	7.07	6.52
H	3	11	12.3	13.1	11.3	12.3	13.3	11.5
H	4	14	16.3	17.5	15.1	16.4	17.7	15.3
H	5	18	20.4	21.8	18.8	20.6	22.1	19.1
H	8	28	30.6	32.8	28.2	30.8	33.1	28.7
H	12	42	47.8	51.1	44.0	48.1	51.7	44.8
M	15	53	63.3	67.7	56.7	63.7	68.5	57.7
M	20	70	81.7	87.3	73.2	82.3	88.4	74.5
M	25	88	102	109	91.5	103	110	93.1
<b>BALANCED PORT THERMOSTATIC EXPANSION VALVES</b>								
EBS	5	18	20.8	20.7	17.8	21.0	21.0	18.1
EBS	7	25	28.7	28.6	24.6	28.9	28.9	25.0
EBS	9	32	38.1	36.3	29.5	38.4	36.7	30.0
EBS-O	12	42	47.8	51.1	41.5	48.1	51.7	42.3
O	16	56	63.3	67.7	59.4	63.7	68.5	60.4
O	23	81	96.6	108	92.6	94.2	109	94.2
O	32	110	130	150	129	131	152	131
O	40	140	163	188	161	164	190	164
V	35	120	143	153	126	144	155	128
V	45	160	184	197	162	185	199	164
V	55	190	225	240	198	226	243	201
W	80	280	347	371	291	350	376	296
W	110	390	486	—	—	490	—	—
<b>CONVENTIONAL CARTRIDGE THERMOSTATIC EXPANSION VALVES</b>								
Q-EQ-SQ	0	0.59	0.82	0.87	0.80	0.82	0.88	0.82
Q-EQ-SQ	1	0.88	1.84	1.97	1.80	1.85	1.99	1.83
Q-EQ-SQ	2	1.8	2.65	2.84	2.60	2.67	2.87	2.65
Q-EQ-SQ	3	3.5	4.08	4.37	4.00	4.11	4.42	4.07
Q-EQ-SQ	4	5.3	5.72	6.11	5.60	5.76	6.19	5.70
Q-EQ-SQ	5	7.0	8.17	8.73	8.01	8.23	8.84	8.15
Q-EQ-SQ	6	8.8	11.0	11.8	10.8	11.1	11.9	11.0
<b>BALANCED PORT CARTRIDGE THERMOSTATIC EXPANSION VALVES</b>								
BQ-EBQ-SBQ	AAA	0.70	0.85	0.99	0.95	0.85	1.00	0.97
BQ-EBQ-SBQ	AA	1.2	1.84	1.97	1.80	1.85	1.99	1.83
BQ-EBQ-SBQ	A	3.5	4.08	4.37	4.00	4.11	4.42	4.07
BQ-EBQ-SBQ	B	7.0	6.94	7.42	6.80	6.99	7.51	6.92
BQ-EBQ-SBQ	C	11	12.3	13.1	12.0	12.3	13.3	12.2

REFRIGERANT	LIQUID TEMPERATURE ENTERING TEV °C							
	-10°	0°	10°	20°	30°	40°	50°	60°
	CORRECTION FACTOR, CF LIQUID TEMPERATURE							
134a	1.64	1.52	1.39	1.26	1.13	1.00	0.87	0.73
409A	1.51	1.41	1.31	1.21	1.11	1.00	0.89	0.78

EVAPORATOR TEMPERATURE °C	PRESSURE DROP ACROSS TEV (bar)							
	2	4	6	8	10	12	14	16
	CORRECTION FACTOR, CF PRESSURE DROP							
5°	0.71	1.00	1.22	1.41	1.58	1.73	1.87	2.00
-5° & -15°	0.58	0.82	1.00	1.15	1.29	1.41	1.53	1.63

These factors include corrections for liquid refrigerant density and net refrigerating effect and are based on an evaporator temperature of -15°C. However, they may be used for any evaporator temperature from -15°C to 5°C since the variation in the actual factors across this range is insignificant.

**TEV Capacity = TEV Rating x CF Liquid Temperature x CF Pressure Drop** — Example: Actual capacity of a nominal 1-1/2 ton R-134a Type FB valve at -5°C evaporator, 8 bar pressure drop across the TEV, and a 30°C liquid temperature entering the TEV = 7.01 (from rating chart) x 1.13 (CF liquid temperature) x 1.15 (CF pressure drop) = 9.11 kW.

# THERMOSTATIC EXPANSION VALVES

22, 407C

## Air Conditioning, Heat Pump and Commercial Refrigeration Applications

VALVE TYPES	NOMINAL CAPACITY	NOMINAL CAPACITY	REFRIGERANT								
			22						407C		
			RECOMMENDED THERMOSTATIC CHARGE								
			VC, VCP100, VGA			VZ, VZP40			NC, NCP100, NGA		
			EVAPORATOR TEMPERATURE °C								
ton	kW	5°	-5°	-15°	-20°	-30°	-40°	5°	-5°	-15°	
FB	1/4	0.88	1.00	1.12	1.03	1.04	0.80	0.63	0.91	1.01	0.91
FB	1/2	1.8	1.99	2.25	2.06	2.08	1.61	1.25	1.81	2.02	1.82
FB	1	3.5	3.76	4.24	3.88	3.69	2.52	1.96	3.42	3.80	3.43
FB	1-1/2	5.3	6.01	6.78	6.21	5.68	3.57	2.78	5.47	6.08	5.48
FB-S	2	7.0	6.87	7.75	7.10	6.78	4.68	3.65	6.26	6.96	6.27
FB-S	3	11	10.9	12.3	11.3	10.6	7.17	5.59	9.94	11.1	9.97
FB-S	4	14	13.4	15.1	13.9	13.1	8.77	6.84	12.2	13.6	12.3
S	5	18	16.7	18.8	17.0	16.4	11.8	9.22	15.2	16.9	15.0
S	8	28	25.7	29.0	24.6	23.4	15.9	12.3	23.4	26.0	21.8
S	10	35	32.1	36.2	30.8	29.3	19.8	15.3	29.2	32.5	27.2
S	15	53	49.8	56.2	47.7	46.1	31.2	24.9	45.3	50.4	42.2
H	2-1/2	8.8	8.04	8.90	8.12	8.12	5.09	4.28	7.32	7.99	7.17
H	5-1/2	19	18.0	19.9	18.2	18.0	11.1	9.34	16.4	17.9	16.1
H	7	25	22.5	24.9	22.7	21.7	12.5	10.5	20.5	22.4	20.1
H	11	39	33.8	37.4	34.1	31.6	17.0	14.3	30.7	33.5	30.1
H	16	56	48.9	54.1	49.4	45.6	24.3	20.4	44.5	48.6	43.6
H	20	70	71.4	79.1	72.1	68.9	39.5	33.2	65.0	70.9	63.7
M	21	74	69.0	77.9	75.3	74.8	53.6	45.2	62.9	69.9	66.5
M	26	91	85.1	96.0	92.9	96.7	75.7	63.9	77.5	86.1	82.0
M	34	120	109	123	119	120	89.1	75.2	99.4	111	105
M	42	150	135	152	147	151	107	86.2	123	137	130
BALANCED PORT THERMOSTATIC EXPANSION VALVES											
ER-RC	1	3.5	3.21	3.62	3.32	—	—	—	2.92	3.25	2.93
ER-RC	1-1/2	5.3	5.62	6.34	5.81	—	—	—	5.12	5.69	5.13
ER-RC	2	7.0	7.39	8.33	7.63	—	—	—	6.72	7.48	6.74
ER-RC	3	11	10.3	11.6	10.6	—	—	—	9.35	10.4	9.38
ER-RC	4	14	13.5	15.2	13.9	—	—	—	12.3	13.7	12.3
ER-RC	5	18	16.1	18.1	16.6	—	—	—	14.6	16.3	14.7
ER-RC	6	21	19.3	21.7	18.5	—	—	—	17.5	19.5	16.3
ER	8	28	25.7	29.0	26.5	—	—	—	23.4	26.0	23.4
ER	12-1/2	35	33.5	37.8	34.6	—	—	—	30.5	33.9	30.6
ER	15	44	38.9	43.8	40.1	—	—	—	35.4	39.3	35.5
EBS	8	28	27.4	29.5	25.4	24.5	16.8	13.0	24.9	26.5	22.4
EBS	11	39	37.0	39.9	34.3	33.1	22.7	17.5	33.7	35.8	30.3
EBS	15	53	49.7	54.4	43.7	42.0	29.1	23.4	45.3	48.8	38.6
EBS-O	20	70	71.9	76.7	60.8	58.3	40.2	29.6	65.5	68.8	53.7
O	30	110	98.2	106	91.8	84.8	56.5	49.1	89.4	94.9	81.1
O	38	130	122	132	110	102	70.3	60.9	111	118	97.3
O	40	140	129	145	115	111	86.1	74.6	118	130	102
O	55	190	177	198	157	150	98.2	83.0	161	177	139
O	70	250	235	262	209	198	111	90.4	214	235	184
O	90	320	289	323	255	243	137	111	263	290	226
V	52	180	167	187	180	190	121	101	152	168	159
V	70	250	235	262	253	265	167	138	214	235	224
V	100	350	321	359	347	355	214	178	292	322	306
W	135	470	459	514	496	507	307	255	418	461	438
W	180	630	607	—	—	—	—	—	553	—	—
CONVENTIONAL CARTRIDGE THERMOSTATIC EXPANSION VALVES											
Q-EQ-SQ	0	1.2	1.12	1.27	1.14	1.10	0.79	0.62	1.02	1.14	1.01
Q-EQ-SQ	1	2.6	2.41	2.72	2.45	2.50	1.99	1.55	2.19	2.44	2.16
Q-EQ-SQ	2	3.5	3.21	3.62	3.27	3.27	2.52	1.96	2.92	3.25	2.88
Q-EQ-SQ	3	5.3	4.82	5.43	4.90	4.65	3.22	2.51	4.39	4.88	4.33
Q-EQ-SQ	4	8.8	8.03	9.06	8.16	8.25	6.43	5.02	7.31	8.13	7.21
Q-EQ-SQ	5	12	11.2	12.7	11.4	11.4	8.77	6.84	10.2	11.4	10.1
Q-EQ-SQ	6	18	15.4	17.4	15.7	15.1	10.7	8.33	14.0	15.6	13.8
BALANCED PORT CARTRIDGE THERMOSTATIC EXPANSION VALVES											
BQ-EBQ-SBQ	AAA	1.2	1.12	1.27	1.14	1.10	0.79	0.62	1.02	1.14	1.01
BQ-EBQ-SBQ	AA	2.3	2.41	2.72	2.45	2.50	1.99	1.55	2.19	2.44	2.16
BQ-EBQ-SBQ	A	5.3	5.14	5.80	5.23	5.03	3.57	2.78	4.68	5.20	4.61
BQ-EBQ-SBQ	B	11	8.99	10.1	9.14	8.95	6.58	5.13	8.19	9.10	8.08
BQ-EBQ-SBQ	C	18	16.7	18.8	17.0	16.4	11.8	9.22	15.2	16.9	15.0

REFRIGERANT	LIQUID TEMPERATURE ENTERING TEV °C							
	-10°	0°	10°	20°	30°	40°	50°	60°
22	1.52	1.42	1.32	1.21	1.11	1.00	0.89	0.78
407C	1.73	1.59	1.45	1.30	1.15	1.00	0.84	0.67

EVAPORATOR TEMPERATURE °C	PRESSURE DROP ACROSS TEV (bar)							
	2	4	6	8	10	12	14	16
5°	0.58	0.82	1.00	1.15	1.29	1.41	1.53	1.63
-5° & -15°	0.50	0.71	0.87	1.00	1.12	1.22	1.32	1.41
-20° & -30°	0.45	0.63	0.77	0.89	1.00	1.10	1.18	1.26
-40°	0.41	0.58	0.71	0.82	0.91	1.00	1.08	1.15

These factors include corrections for liquid refrigerant density and net refrigerating effect and are based on an evaporator temperature of -15°C. However, they may be used for any evaporator temperature from -15°C to 5°C since the variation in the actual factors across this range is insignificant.

**TEV Capacity = TEV Rating x CF Liquid Temperature x CF Pressure Drop** — Example: Actual capacity of a nominal 1-1/2 ton R-22 Type FB valve at -5°C evaporator, 10 bar pressure drop across the TEV, and a 30°C liquid temperature entering the TEV = 6.78 (from rating chart) x 1.11 (CF liquid temperature) x 1.12 (CF pressure drop) = 8.43 kW.

# THERMOSTATIC EXPANSION VALVES

404A, 507

## Air Conditioning, Heat Pump and Commercial Refrigeration Applications

VALVE TYPES	NOMINAL CAPACITY	NOMINAL CAPACITY	REFRIGERANT											
			404A						507					
			RECOMMENDED THERMOSTATIC CHARGE											
			SCP115, SC			SZ, SZP			PC			PZ, PZP		
			EVAPORATOR TEMPERATURE °C											
ton	kW	5°	-5°	-15°	-20°	-30°	-40°	5°	-5°	-15°	-20°	-30°	-40°	
FB	1/8	0.44	0.65	0.71	0.63	0.62	0.45	0.33	0.64	0.70	0.62	0.61	0.44	0.33
FB	1/4	0.88	1.12	1.24	1.10	1.12	0.86	0.65	1.10	1.21	1.08	1.10	0.85	0.64
FB	1/2	1.8	2.25	2.47	2.20	2.11	1.47	1.10	2.21	2.43	2.16	2.07	1.45	1.09
FB	1	3.5	3.90	4.29	3.81	3.43	2.08	1.56	3.83	4.21	3.75	3.38	2.05	1.54
FB	1-1/2	5.3	4.46	4.91	4.36	4.12	2.78	2.09	4.39	4.82	4.29	4.05	2.74	2.06
FB-S	2	7.0	6.43	7.01	6.17	6.42	4.17	3.13	6.32	6.88	6.06	6.44	4.11	3.09
FB-S	3	11	8.72	9.59	8.49	7.90	5.12	3.84	8.57	9.41	8.34	7.77	5.05	3.79
S	4	14	12.9	14.0	12.1	12.3	9.45	8.15	12.6	13.8	11.9	12.1	9.31	8.05
S	6	21	17.8	17.1	14.4	15.2	12.3	9.89	17.5	16.8	14.2	14.9	12.1	9.77
S	7	25	22.7	21.8	18.4	19.3	15.6	12.6	22.3	21.4	18.0	19.0	15.4	12.4
S	10	35	32.5	31.8	28.4	30.3	26.2	23.5	31.9	31.3	27.9	29.8	25.8	23.2
H	1-1/2	5.3	4.84	4.85	4.54	4.94	3.99	3.30	4.76	4.76	4.46	4.86	3.93	3.26
H	3	11	9.04	9.05	7.80	8.23	6.65	5.51	8.88	8.88	7.66	8.09	6.55	5.44
H	4	14	12.9	12.9	10.7	11.3	9.31	7.71	12.7	12.7	10.5	11.1	9.17	7.62
H	6-1/2	23	21.0	21.0	17.4	18.0	14.5	12.0	20.6	20.6	17.1	17.7	14.3	11.8
H	9	32	30.7	30.7	25.5	24.1	16.6	13.8	30.1	30.1	25.0	23.7	16.4	13.6
H	12	42	42.0	42.0	34.9	34.9	26.6	22.0	41.2	41.3	34.2	34.4	26.2	21.8
M	15	53	50.8	55.8	45.3	46.4	39.6	33.2	49.9	54.8	44.5	45.6	39.0	32.8
M	20	70	66.2	72.8	57.5	58.2	49.7	41.7	65.0	71.4	56.5	57.2	48.9	41.2
M	25	88	82.6	90.8	71.7	70.9	58.3	48.9	81.1	89.1	70.4	69.7	57.4	48.3
M	30	110	99.6	110	86.5	84.2	67.5	56.6	97.9	108	85.0	82.8	66.5	55.9
BALANCED PORT THERMOSTATIC EXPANSION VALVES														
EBS	6	21	18.1	18.6	15.7	15.4	10.6	9.87	17.7	18.3	15.4	15.2	10.5	9.75
EBS	7-1/2	26	24.5	25.3	21.3	20.5	13.5	12.6	24.1	24.8	21.0	20.2	13.3	12.4
EBS	10	35	30.2	31.7	25.3	24.6	17.9	15.4	29.6	31.2	24.9	24.2	17.6	15.3
EBS	13	46	43.1	45.9	36.0	34.7	25.5	20.5	42.3	45.1	35.3	34.1	25.2	20.2
O	12	42	42.0	42.0	34.2	34.3	27.2	23.5	41.2	41.3	33.6	33.7	26.8	23.2
O	21	74	67.8	67.9	51.1	46.3	32.6	28.1	66.6	66.6	50.2	45.5	32.1	27.8
O	30	110	97.1	106	81.7	72.8	48.8	42.1	95.4	104	80.3	71.6	48.0	41.6
O	35	120	113	123	94.7	82.6	52.9	45.7	111	120	93.1	81.2	52.2	45.2
O	45	160	145	158	122	103	61.0	52.7	142	155	120	101	60.1	52.1
V	38	130	122	130	113	117	97.5	80.2	120	127	111	115	96.1	79.2
V	50	180	164	174	152	160	139	114	161	171	149	158	137	113
V	70	250	225	239	211	223	195	160	221	235	207	220	192	158
VALVE TYPE	CARTRIDGE	CONVENTIONAL CARTRIDGE THERMOSTATIC EXPANSION VALVES												
Q-EQ-SQ	0	0.59	0.64	0.71	0.67	0.70	0.55	0.48	0.63	0.69	0.66	0.69	0.54	0.47
Q-EQ-SQ	1	0.88	1.45	1.59	1.50	1.58	1.24	1.07	1.42	1.56	1.48	1.56	1.22	1.06
Q-EQ-SQ	2	1.8	2.09	2.33	2.21	2.23	1.63	1.40	2.05	2.29	2.18	2.20	1.60	1.39
Q-EQ-SQ	3	3.5	3.22	3.50	3.03	3.06	2.34	2.02	3.16	3.44	2.98	3.00	2.31	2.00
Q-EQ-SQ	4	5.3	5.14	5.60	4.85	5.04	4.05	3.49	5.05	5.50	4.77	4.95	3.99	3.45
Q-EQ-SQ	5	7.0	6.75	7.36	6.37	6.65	5.40	4.66	6.63	7.22	6.26	6.54	5.32	4.60
Q-EQ-SQ	6	11	9.00	9.81	8.49	8.65	6.75	5.82	8.84	9.63	8.34	8.51	6.65	5.75
VALVE TYPE	CARTRIDGE	BALANCED PORT CARTRIDGE THERMOSTATIC EXPANSION VALVES												
BQ-EBQ-SBQ	AAA	0.70	0.72	0.80	0.75	0.82	0.67	0.58	0.71	0.78	0.74	0.80	0.66	0.57
BQ-EBQ-SBQ	AA	1.2	1.45	1.59	1.50	1.58	1.24	1.07	1.42	1.56	1.48	1.56	1.22	1.06
BQ-EBQ-SBQ	A	3.5	3.21	3.59	3.41	3.70	3.03	2.61	3.15	3.53	3.35	3.63	2.99	2.58
BQ-EBQ-SBQ	B	7.0	5.95	6.48	5.61	5.69	4.41	3.80	5.84	6.36	5.51	5.60	4.34	3.76
BQ-EBQ-SBQ	C	11	9.00	9.81	8.49	8.65	6.75	5.82	8.84	9.63	8.34	8.51	6.65	5.75

REFRIGERANT	LIQUID TEMPERATURE ENTERING TEV °C							
	-10°	0°	10°	20°	30°	40°	50°	60°
	CORRECTION FACTOR, CF LIQUID TEMPERATURE							
404A	1.98	1.79	1.60	1.41	1.21	1.00	0.79	0.56
507	1.92	1.74	1.56	1.37	1.19	1.00	0.79	0.54

These factors include corrections for liquid refrigerant density and net refrigerating effect and are based on an evaporator temperature of -15°C. However, they may be used for any evaporator temperature from -15°C to 5°C since the variation in the actual factors across this range is insignificant.

EVAPORATOR TEMPERATURE °C	PRESSURE DROP ACROSS TEV (bar)							
	2	4	6	8	10	12	14	16
	CORRECTION FACTOR, CF PRESSURE DROP							
5°	0.58	0.82	1.00	1.15	1.29	1.41	1.53	1.63
-5° & -15°	0.50	0.71	0.87	1.00	1.12	1.22	1.32	1.41
-20° & -30°	0.45	0.63	0.77	0.89	1.00	1.10	1.18	1.26
-40°	0.41	0.58	0.71	0.82	0.91	1.00	1.08	1.15

TEV Capacity = TEV Rating x CF Liquid Temperature x CF Pressure Drop — Example: Actual capacity of a nominal 1-1/2 ton R-404A Type FB valve at -5°C evaporator, 10 bar pressure drop across the TEV, and a 30°C liquid temperature entering the TEV = 4.91 (from rating chart) x 1.21 (CF liquid temperature) x 1.12 (CF pressure drop) = 6.65 kW.

# THERMOSTATIC EXPANSION VALVES

410A

## Air Conditioning and Heat Pump Applications

VALVE TYPES	NOMINAL CAPACITY	NOMINAL CAPACITY	REFRIGERANT		
			410A		
			RECOMMENDED THERMOSTATIC CHARGE		
			ZGA		
EVAPORATOR TEMPERATURE °C			5°	-5°	-15°
ton	kW				
<b>BALANCED PORT THERMOSTATIC EXPANSION VALVES</b>					
ER-RC	1	3.5	4.08	4.50	4.12
ER-RC	1-1/2	5.3	7.14	7.88	7.21
ER-RC	2	7.0	9.38	10.4	9.48
ER-RC	3	11	13.1	14.4	13.2
ER-RC	4	14	17.1	18.9	17.3
ER-RC	5	18	20.4	22.5	20.6
ER-RC	6	21	24.5	27.0	23.0
ER	8	28	32.6	36.0	33.0
ER	12-1/2	44	42.5	46.9	43.0
ER	15	53	49.4	54.4	49.9
O	20	70	68.1	75.1	71.5
O	25	88	81.7	90.1	85.8
O	35	120	112	124	118
O	50	180	170	188	179
O	60	210	204	225	215
<b>VALVE TYPE</b>	<b>CARTRIDGE</b>	<b>BALANCED PORT CARTRIDGE THERMOSTATIC EXPANSION VALVES</b>			
BQ-EBQ-SBQ	AAA	1.2	1.43	1.58	1.42
BQ-EBQ-SBQ	AA	2.6	3.06	3.38	3.04
BQ-EBQ-SBQ	A	5.3	6.53	7.20	6.49
BQ-EBQ-SBQ	B	11	11.4	12.6	11.4
BQ-EBQ-SBQ	C	18	21.2	23.4	21.1

REFRIGERANT	LIQUID TEMPERATURE ENTERING TEV °C				
	20°	30°	40°	50°	60°
410A	1.30	1.15	1.00	0.84	0.65

These factors include corrections for liquid refrigerant density and net refrigerating effect and are based on an evaporator temperature of -15°C. However, they may be used for any evaporator temperature from -15°C to 5°C since the variation in the actual factors across this range is insignificant.

EVAPORATOR TEMPERATURE °C	PRESSURE DROP ACROSS TEV (bar)				
	8	11	14	17	20
5°	CORRECTION FACTOR, CF PRESSURE DROP				
5°	0.85	1.00	1.13	1.24	1.35
-5° & -15°	0.76	0.89	1.00	1.10	1.20

**TEV Capacity = TEV Rating x CF Liquid Temperature x CF Pressure Drop** — Example: Actual capacity of a nominal 4 ton R-410A Type RC valve at -15°C evaporator, 17 bar pressure drop across the TEV, and a 30°C liquid temperature entering the TEV = 17.3 (from rating chart) x 1.15 (CF liquid temperature) x 1.10 (CF pressure drop) = 21.9 kW.

# REFRIGERANT DISTRIBUTORS & AUXILIARY SIDE CONNECTORS



**1126**



**1651**

Side Connection distributors for heat pump, hot gas defrost, and hot gas bypass systems.



**ASC**

(Auxiliary Side Connectors) for hot gas defrost, hot gas bypass and heat pump systems.

U.S. Patent No. 3,563,055

The Sporlan Distributor is an efficient refrigerant distributing device that assures uniform feeding of refrigerant to all passes of a multi-circuited evaporator. It can be used with any conventional externally equalized thermostatic expansion valve.

Auxiliary Side Connectors (ASC) permit the conversion of conventional Sporlan refrigerant distributors to hot gas bypass, hot gas defrost or heat pump service. Sporlan's distributors and auxiliary side connectors are suitable for use with R-410A.

## Refrigerant Distributors

CONNECTION SIZE	TEV MODEL	DISTRIBUTOR TYPE	MAXIMUM NUMBER of CIRCUITS				NOZZLE TYPE	MATERIAL
			3/16	1/4	5/16	3/8		
1/2 SAE	BQ, Q, R, RC	1603	6	4	—	—	PERM.	#360 Brass
		1606	9	6	4	—	PERM.	
		1605	6	4	—	—	L	
		1608	9	6	4	—	L	
1/2 ODM	EBQ, EQ, R, RC, S, SBQ, SQ	D260	6	4	—	—	L	
		D262	9	7	4	—	L	
5/8 ODM	EQ, R, RC, S	1620	6	4	—	—	J	
		1622	9	7	4	—	J	
7/8 ODM	EBQ, EBS, EQ, O, S	1112	7	6	4	2	G	
		1113	12	8	6	4	G	
1-1/8 ODM	EBS, O, S	1115	15	10	9	6	E	
		1116	20	15	—	—	E	
1-3/8 ODM	EBS, O, W	1117	18	15	9	7	C	
		1126	24	18	15	12	C	
		1128	28	25	21	16	C	
1-5/8 ODM	O, W	1125	28	24	20	16	A	
		1127	37	30	26	20	A	
		1143	40	36	30	24	A	
Type H Valve	H	1109	10	8	6	4	G	
		1124	30	23	18	15	E	
		1192	11	10	6	6	G	
Type M/V Valve	M, V	1121	34	24	20	16	C	
		1193	26	21	18	16	C	

## Side Connection Distributors

CONNECTION SIZE	TEV MODEL	DISTRIBUTOR TYPE	MAXIMUM NUMBER of CIRCUITS				NOZZLE TYPE	SIDE CONNECTION	MATERIAL
			3/16	1/4	5/16	3/8			
1/2 SAE	BQ, Q, R, RC	1650 (R)	7	5	—	—	PERM.	3/8 or 1/2 ODF	#360 Brass
5/8 ODM	EBQ, EQ, R, RC, S, SBQ	1651 (R)	7	5	—	—	J (R)	3/8 or 1/2 ODF	
7/8 ODM	EBQ, EBS, EQ, O, S	1653 (R)	12	9	6	4	G (R)	1/2 or 5/8 ODF	
1-1/8 ODM	EBS, O, S	1655 (R)	20	12	10	7	E (R)	1/2 or 5/8 ODF	
1-3/8 ODM	EBS, O, W	1657 (R)	26	18	14	11	C (R)	5/8 or 7/8 ODF	
1-5/8 ODM	O, W	1659 (R)	32	24	18	14	A (R)	7/8 or 1-1/8 ODF	

## Auxiliary Side Connectors

TYPE	CONNECTION SIZES – Inches			NOZZLE SIZE	USED with DISTRIBUTOR TYPE
	INLET ODM SOLDER	OUTLET ODF SOLDER	AUXILIARY ODF SOLDER		
ASC-5-4	5/8	5/8	1/2	J	1620, 1622
ASC-7-4	7/8	7/8	1/2	G	1112, 1113
ASC-9-5	1-1/8	1-1/8	5/8	E	1115, 1116
ASC-11-7	1-3/8	1-3/8	7/8	C	1117, 1126, 1128
ASC-13-9	1-5/8	1-5/8	1-1/8	A	1125, 1127, 1143

## Nomenclature/Ordering Instructions

To order an 1126 distributor with 16 – 1/4” circuits and number 15 nozzle use the following nomenclature:

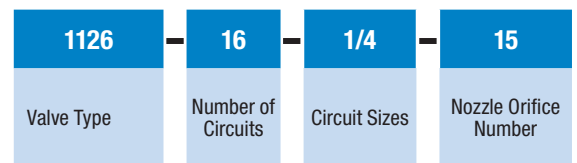

# 2-WAY SOLENOID VALVES

22, 134a, 404A, 407C, 409A, 410A, 507

## 6 Proven Benefits of Sporlan Solenoid Valves

- Can be mounted in a horizontal or vertical line.
- Molded coil for all sizes.
- Class “F” temperature rating – Coil types MKC-1, OMKC-1, MKC-2 and OMKC-2.
- Extremely rugged, simple design – few parts.
- “E” Series may be brazed without disassembly.
- Tight closing through use of synthetic seating material.

Sporlan Solenoid Valves are made in two general types, normally closed and normally open. The normally closed types may be further sub-divided into direct acting and pilot operated types. All Sporlan solenoid valves are designed for liquid, suction and discharge gas applications.

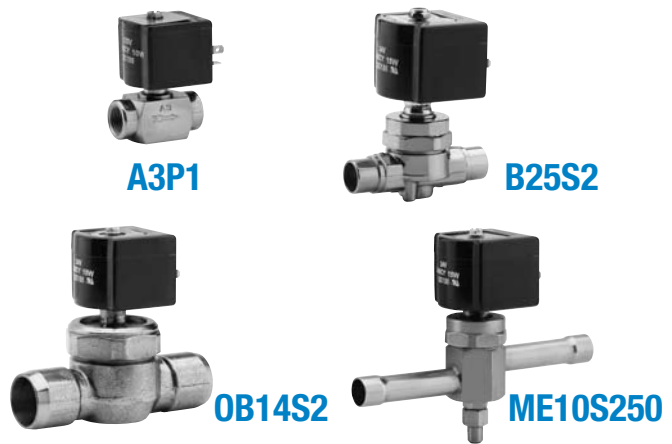

Most Sporlan Solenoid Valves are Listed by Underwriters' Laboratories, Inc. – Guide No. Y10Z – File No. MH4576 and Canadian Standards Association – Guide 440-A-0, Class 3221, File 19953 and CE provisions of the LVD 73/23/EEC and PED 97/23/EC.

## Liquid Capacities – kW

TYPE NUMBER		kW of REFRIGERATION**														
“E” SERIES VALVES	“A” & “B” SERIES VALVES	22					134a					404A				
		PRESSURE DROP – bar*														
		0.07	0.14	0.21	0.28	0.35	0.07	0.14	0.21	0.28	0.35	0.07	0.14	0.21	0.28	0.35
E3	A3	3.19	4.61	<b>5.71</b>	6.65	7.49	2.98	<b>4.30</b>	5.33	6.21	6.99	2.10	3.03	<b>3.75</b>	4.37	4.92
E5	—	5.69	8.10	<b>9.96</b>	11.5	12.9	5.31	<b>7.56</b>	9.29	10.8	12.1	3.76	5.35	<b>6.57</b>	7.61	8.52
E6	B6	10.2	14.3	<b>17.5</b>	20.2	22.5	9.50	<b>13.4</b>	16.3	18.8	21.0	6.74	9.49	<b>11.6</b>	13.3	14.9
E9	B9	16.6	23.4	<b>28.6</b>	33.0	36.9	15.5	<b>21.8</b>	26.7	30.8	34.4	11.0	15.5	<b>18.9</b>	21.8	24.4
E10	B10	22.7	32.1	<b>39.3</b>	45.4	50.7	21.2	<b>30.0</b>	36.7	42.3	47.3	15.0	21.2	<b>26.0</b>	30.0	33.5
E14	B14	32.3	45.6	<b>55.8</b>	64.4	71.9	30.1	<b>42.5</b>	52.1	60.1	67.1	21.4	30.2	<b>36.9</b>	42.6	47.6
E19	B19	49.3	70.0	<b>85.8</b>	99.2	111	46.0	<b>65.3</b>	80.1	92.6	104	32.6	46.2	<b>56.7</b>	65.5	73.3
E25	B25	84.3	119	<b>147</b>	169	189	78.7	<b>111</b>	137	158	177	55.7	78.9	<b>96.8</b>	112	125
E35	—	118	166	<b>204</b>	236	263	110	<b>155</b>	190	220	246	77.7	110	<b>135</b>	156	174
E42	—	260	368	<b>451</b>	520	582	243	<b>343</b>	420	485	543	172	243	<b>298</b>	344	384

TYPE NUMBER		kW of REFRIGERATION**									
“E” SERIES VALVES	“A” & “B” SERIES VALVES	407C					507				
		PRESSURE DROP – bar*									
		0.07	0.14	0.21	0.28	0.35	0.07	0.14	0.21	0.28	0.35
E3	A3	2.92	4.21	<b>5.22</b>	6.08	6.85	2.05	2.97	<b>3.68</b>	4.29	4.82
E5	—	5.22	7.43	<b>9.13</b>	10.6	11.8	3.68	5.24	<b>6.44</b>	7.45	8.35
E6	B6	9.36	13.2	<b>16.1</b>	18.5	20.7	6.60	9.28	<b>11.3</b>	13.1	14.6
E9	B9	15.3	21.5	<b>26.3</b>	30.3	33.9	10.8	15.2	<b>18.5</b>	21.4	23.9
E10	B10	20.9	29.5	<b>36.1</b>	41.7	46.6	14.7	20.8	<b>25.5</b>	29.4	32.8
E14	B14	29.7	41.9	<b>51.2</b>	59.1	66.1	20.9	29.5	<b>36.1</b>	41.7	46.6
E19	B19	45.3	64.2	<b>78.7</b>	91.0	102	31.9	45.2	<b>55.5</b>	64.2	71.8
E25	B25	77.4	110	<b>134</b>	155	174	54.6	77.3	<b>94.8</b>	110	123
E35	—	108	153	<b>187</b>	216	242	76.1	108	<b>132</b>	152	170
E42	—	239	338	<b>414</b>	478	534	168	238	<b>292</b>	337	376

TYPE NUMBER		kW of REFRIGERATION**				
“E” SERIES VALVES		410A				
		PRESSURE DROP – bar*				
		0.07	0.14	0.21	0.28	0.35
E3		—	—	—	—	—
E5-HP		5.37	6.44	<b>9.16</b>	11.3	13.0
E6-HP		9.63	11.5	<b>16.1</b>	19.7	22.7
E9-HP		15.7	18.7	<b>26.4</b>	32.3	37.2
E10-HP		21.5	25.6	<b>36.2</b>	44.3	51.2
E14-HP		39.5	36.4	<b>51.4</b>	62.9	72.6
E19-HP		46.5	55.7	<b>79.0</b>	97.0	112
E25-HP		79.6	95.2	<b>135</b>	165	191
E35-HP		129	157	<b>230</b>	286	335
E42-HP		246	294	<b>415</b>	508	587

\*Do not use below 0.07 bar pressure drop, except Types E3 and A3 valves.

\*\*Capacities are based on 5°C evaporator and 38°C liquid.

Valve types whether Normally Closed or Normally Open have the same capacities, i.e., B10 or OB10, E10 or OE10.



# 2-WAY SOLENOID VALVES

22, 134a, 404A, 407C, 507

## Built-In Check Valve Series

A solenoid valve with a built-in check valve is designed to replace a liquid line solenoid valve in parallel with a check valve for reverse flow. This valve may be applied in the liquid line of a supermarket case for positive shutoff during pumpdown control, while allowing full flow in the reverse direction during reverse gas defrost. It may also be used in the liquid line of a heat pump to prevent migration of refrigerant to the outdoor unit during the heating mode, while allowing full flow in the reverse direction during the cooling mode.



**Note: This valve will not close in the reverse flow/cooling mode.**

**Maximum Rated Pressures** — Valve Type E42 Series – **31 bar**  
All other valve types – **34.5 bar**

**Electrical Specifications** — **Standard Coil Ratings** – MKC-1, OMKC-1, MKC-2 and OMKC-2: 24/50-60, 120/50-60, 208-240/50-60. Dual Voltage 4 Wire Coils – 120-208-240/50-60, slight additional cost.

Available with junction box or conduit boss at no extra charge. For other voltages and cycles consult Sporlan.

**Interchangeability of Coils** — One size coil MKC-1 for Types A3, E3, B6, MB6, E5, E6, ME6, E35 and ME35 series. One size MKC-2 for types B9, MB9, E9 and ME9 series through the E42 and ME42 series.

OMKC-1 and OMKC-2 Coil Assemblies are for use on Normally Open valves.

## Specifications for Reverse Refrigeration Flow, Liquid Line Capacity – kW\*\*

VALVE TYPE	CONNECTIONS Inches	EVAPORATOR °C									
		R-22 0.21 bar		R-134a 0.14 bar		R-404A 0.21 bar		R-407C 0.21 bar		R-507 0.21 bar	
		5	-20	5	-20	5	-20	5	-20	5	-20
<b>C(M)B9, C(M)E9</b>	3/8, 1/2 ODF, 3/8 SAE	23.2	21.8	17.9	16.2	—	13.7	21.5	19.7	—	13.4
<b>C(M)B10, C(M)E10</b>	1/2 SAE, 1/2, 5/8 ODF	28.5	26.7	21.8	19.7	—	16.9	26.0	23.9	—	16.5
<b>C(M)B14, C(M)E14</b>	5/8 ODF	45.4	42.9	35.9	32.7	—	27.1	42.2	38.7	—	26.7
<b>C(M)B19, C(M)E19+</b>	5/8, 7/8 ODF	32.7	31.0	21.8	19.7	—	19.0	28.8	26.4	—	17.9

\*\* Valve sizing should be based on expected reverse liquid flow condensing capabilities of the evaporator(s) being defrosted.  
+ Due to flow restrictions, C(M)E19 model capacity does not surpass C(M)E14 models until pressure drop exceeds 0.70 bar.  
See page 25 for Forward Refrigerant Flow.  
Liquid capacities shown in the above table are based on 38°C liquid temperature entering the valves.

## Specifications

TYPE NUMBER						CONNECTIONS Inches	PORT SIZE mm	MOPD bar AC	WATTS
"E" SERIES EXTENDED CONNECTIONS			"A" & "B" SERIES VALVES						
WITHOUT MANUAL LIFT STEM		WITH MANUAL LIFT STEM	WITHOUT MANUAL LIFT STEM		WITH MANUAL LIFT STEM				
Normally Closed	Normally Open	Normally Closed	Normally Closed	Normally Open	Normally Closed				
—	—	—	A3P1	—	—	3/8 NPT Female	2.6	20.5	10
—	—	—	A3F1	—	—	1/4 SAE Flare			
E3S120	—	—	A3S1	—	—	1/4 ODF Solder			
E3S130	—	—	A3S1	—	—	3/8 ODF Solder			
E5S120	—	—	—	—	—	1/4 ODF Solder	3.8	20.5	10
E5S130 (-HP)	—	—	—	—	—	3/8 ODF Solder			
—	—	—	B6P1	—	MB6P1	3/8 NPT Female	4.8	20.5	10
—	—	—	B6F1	—	MB6F1	3/8 SAE Flare			
E6S130 (-HP)	—	ME6S130 (-HP)	B6S1	—	MB6S1	3/8 ODF Solder			
E6S140	—	ME6S140 (-HP)	B6S1	—	MB6S1	1/2 ODF Solder			
—	—	—	B9P2	OB9P2	MB9P2	3/8 NPT Female	7.1	*20.5	15
—	—	—	B9F2	OB9F2	MB9F2	3/8 SAE Flare			
E9S230	OE9S230	ME9S230	—	—	—	3/8 ODF Solder	7.9	*20.5	15
E9S240 (-HP)	OE9S240	ME9S240 (-HP)	B9S2	OB9S2	MB9S2	1/2 ODF Solder			
—	—	—	B10F2	—	MB10F2	1/2 SAE Flare	11.1	*20.5	15
E10S240 (-HP)	OE10S240	ME10S240	—	—	—	1/2 ODF Solder			
E10S250	OE10S250	ME10S250	B10S2	—	MB10S2	5/8 ODF Solder	15.1	*20.5	15
—	—	—	B14P2	OB14P2	MB14P2	1/2 NPT Female			
E14S250 (-HP)	OE14S250	ME14S250 (-HP)	B14S2	OB14S2	MB14S2	5/8 ODF Solder	19.8	*20.5	15
—	—	—	B19P2	OB19P2	—	3/4 NPT Female			
E19S250	OE19S250	ME19S250	B19S2	OB19S2	MB19S2	5/8 ODF Solder	25.4	20.5	10
E19S270 (-HP)	OE19S270	ME19S270 (-HP)	B19S2	OB19S2	MB19S2	7/8 ODF Solder			
—	—	—	B25P2	—	MB25P2	1 NPT Female	33.3	*20.5	15
E25S270 (-HP)	OE25S270	ME25S270	B25S2	OB25S2	MB25S2	7/8 ODF Solder			
E25S290 (-HP)	OE25S290	ME25S290 (-HP)	B25S2	OB25S2	MB25S2	1-1/8 ODF Solder	25.4	20.5	10
E35S190	OE35S190	ME35S190 (-HP)	—	—	—	1-1/8 ODF Solder			
E35S1110	OE35S1110	ME35S1110 (-HP)	—	—	—	1-3/8 ODF Solder	33.3	*20.5	15
—	—	—	—	—	—	1-5/8 ODF Solder			
E42S2130 (-HP)	OE42S2130	ME42S2130	—	—	—	1-5/8 ODF Solder	33.3	*20.5	15
E42S2170	OE42S2170	ME42S2170	—	—	—	2-1/8 ODF Solder			

\*All normally open valves are rated at 19 bar, except OE35 which is rated at 20.5 bar.  
For complete information consult your nearest Sporlan Wholesaler, or email europecold@parker.com and request Bulletin 30-10.

# 2-WAY SOLENOID VALVES

22, 134a, 404A, 407C, 507

## E Series – Valve Nomenclature/Ordering Instructions

M	E	10	S	2	5	0	S	HP
Manual Lift Stem	Design Series	Port Size in 1/32"	Connections Solder	Coil Size Q, W	Connection Size in 1/8"	*Connections 0 - ODF x ODF 1 - ODF x ODM 2 - ODM x ODF 3 - ODM x ODM	Coil Connection S - Spade E - DIN 43650A	for R-410A only

Type "E" series is identified by an expanded nomenclature. The system of valve identity based on port size. In addition, the "E" series identifies the connection size and type. The advantage of the "E" series nomenclature system is that it allows ease in valve identification of the standard line and can provide considerable information about special valves supplied to manufacturers.

**Q** The MKC-1, OMKC-1, MKC-2 and OMKC-2 are fungus proof and meet MIL-I-631C.

**W** The standard MKC-1 and MKC-2 are class "F" rated.

\* Standard connections are ODF inlet x ODF outlet on "E" Series valves. Minimum quantities may be required for other connections.



## A, B and W Series – Valve Nomenclature/Ordering Instructions

0	D	M	B	25	S	2	*	S
Normally Open	Disc Type D - Direct Connected C - Built-in Check Valve	Manual Lift Stem	Design or Series A, B, & W Series	Port Size in 1/32"	Connections P - Pipe F - SAE Flare S - ODF Solder	Coil Size Q, W	Overall Length	Coil Connection S - Spade E - DIN 43650A

The above prefixes may be added to basic valve type number (B25S2) to request special features.

Normally open valves available in B9, E9 through E42 series only, and require OMKC-2 Coil Assembly. Add prefix D for direct connected assembly in MA32 and MA17A3 series. Example DMA32P3.

## Application

### Compressor Capacity Reduction Service

Sporlan Solenoid Valves may be used in conjunction with Sporlan Discharge Bypass Valves for capacity reduction service. For capacity information and further details on the Discharge Bypass Valves see page 44.

### Filter-Driers are Essential

Dirt and other system contaminants present a problem for refrigeration and air conditioning controls. Since pilot operated solenoid valves operate with rather close tolerances, system cleanliness is imperative. The Sporlan Catch-All Filter-Drier filters out minute particles of dirt and other foreign matter, thus protecting the valve.

Sporlan recommends using a Catch-All Filter-Drier ahead of every solenoid valve on all refrigeration and air conditioning applications. Contact Sporlan before adding a Catch-All Filter-Drier in the discharge line.

### Transformer Selection for Low-Voltage Control Systems

Many systems utilize low voltage controls, requiring the use of a transformer for voltage reduction, normally to 24 volts. The selection of a transformer is not accomplished by merely selecting one that has the proper voltage requirements. The volt-ampere (VA) rating is equally important. To determine the VA requirement for a specific solenoid valve, refer to the chart below. It should be noted, that insufficient transformer capacity will result in reduced operating power or lowering of the MOPD value.

If more than one solenoid valve and/or other accessories are operated from the same transformer, then the transformer VA rating must be determined by adding the individual accessories' VA requirements.

### Fusing

Sporlan Solenoid Valves are not supplied with fuses. Fusing should be according to local codes. We recommend fusing the hot leg of the valve wiring with fast acting fuses and the valve should be grounded either through the fluid piping or the electrical conduit.

COIL KIT	24 VOLTS/ 50-60 CYCLES		120 VOLTS/ 50-60 CYCLES		240 VOLTS/ 50-60 CYCLES		TRANSFORMER RATING VOLTS-AMPERES FOR 100% OF RATED MOPD OF VALVE
	CURRENT-AMPERES		CURRENT-AMPERES		CURRENT-AMPERES		
	INRUSH	HOLDING	INRUSH	HOLDING	INRUSH	HOLDING	
MKC-1 OMKC-1	1.9	0.63	0.39	0.14	0.19	0.09	60
MKC-2 OMKC-2	3.1	1.4	0.60	0.26	0.31	0.13	100

- All current values are based on 60 cycles.
- Volt-ampere ratings are based on inrush currents.
- Above values are based on the most severe conditions.

# 3-WAY HEAT RECLAIM VALVES

22, 134a, 404A, 407C, 409A, 410A, 507

Sporlan Heat Reclaim Valves are tight synthetic seating three way valves designed specifically to divert hot gas from the normal to auxiliary condenser.

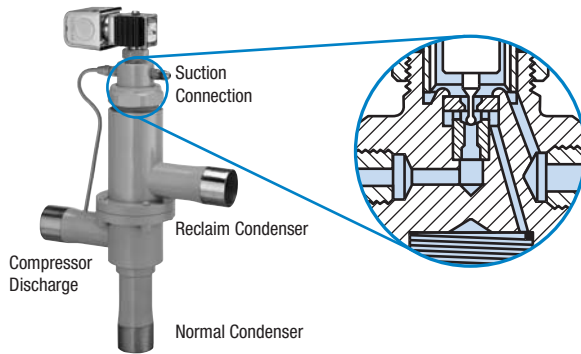

When the upper pilot port is open, the cavity above the piston is open to suction. Pump out of the reclaim condenser is controlled by the bleed rate through the piston. After the reclaim condenser has been pumped out, and the valve continues to operate in the normal condenser mode, **all flow ceases**, thus eliminating high to low side bleed and the resulting capacity loss.

## “C” Type

**Normal (Outdoor) Condenser – De-energized** – With the pilot valve de-energized, high side pressure is prevented from entering cavity above the piston-seat assembly. At the same time the upper pilot port is opened to suction pressure. The resulting pressure differential across the piston moves the piston-seat assembly to close the reclaim (upper) main port. The non bleed piston prevents high to low side bleed with the system operating in the normal condenser mode.

## Operation “B” Type

**Normal (Outdoor) Condenser – De-energized** – With the pilot valve de-energized, high side pressure is prevented from entering the cavity above the piston-seat assembly. At the same time the upper pilot port is opened to suction pressure. The resulting pressure differential across the piston moves the piston-seat assembly to close the reclaim (upper) main port.

## “B” and “C” Type

**Reclaim (Reheat) Condenser – Energized** – When the pilot valve is energized, high side pressure is permitted to flow thru the lower pilot port. At the same time the upper pilot port is closed to suction. High side pressure on top of the piston moves the piston-seat assembly to close the normal condenser port and open the reclaim (upper) main port. With the upper pilot port closed there is no high to low side bleed loss with the system operating in the reclaim mode.

## Capacity – kW

Capacities are based on 38°C condensing temperature isentropic compression plus 28°C, evaporator temperature as shown plus 14°C superheat suction gas.

EVAPORATOR TEMP. °C	REFRIGERANT																							
	22								134a								404A							
	PRESSURE DROP – bar																							
	0.14				0.28				0.14				0.28				0.14				0.28			
	B5D	8D	12D	16D	B5D	8D	12D	16D	B5D	8D	12D	16D	B5D	8D	12D	16D	B5D	8D	12D	16D	B5D	8D	12D	16D
5	16.8	35.9	103	249	23.4	50.3	149	357	14.1	29.9	85.5	206	19.5	41.9	123	295	15.0	32.1	93.9	226	20.8	44.9	135	324
0	16.6	35.3	102	245	23.0	49.5	146	351	13.8	29.3	83.7	202	19.1	41.0	120	289	14.6	31.3	91.7	220	20.3	43.9	132	316
-5	16.3	34.7	99.9	240	22.6	48.6	144	345	13.5	28.6	81.8	197	18.7	40.1	118	283	14.2	30.5	89.3	215	19.7	42.8	128	308
-10	16.0	34.1	98.1	236	22.2	47.7	141	339	13.2	28.0	79.9	192	18.2	39.2	115	276	13.8	29.7	86.9	209	19.2	41.6	125	300
-15	15.7	33.4	96.2	231	21.8	46.8	138	332	12.8	27.3	77.9	188	17.8	38.2	112	269	13.5	28.9	84.4	203	18.7	40.4	121	291
-20	15.4	32.8	94.2	227	21.3	45.9	135	325	12.5	26.6	75.9	183	17.4	37.3	109	262	13.0	28.0	81.8	197	18.1	39.2	118	282
-25	15.1	32.1	92.2	222	20.9	44.9	133	318	12.2	25.9	73.9	178	16.9	36.3	106	255	12.6	27.1	79.2	190	17.5	37.9	114	273
-30	14.7	31.4	90.1	217	20.4	43.9	130	311	—	—	—	—	—	—	—	—	12.2	26.2	76.5	184	16.9	36.6	110	264
-35	14.4	30.7	88.0	212	20.0	42.9	127	304	—	—	—	—	—	—	—	—	11.8	25.2	73.7	177	16.3	35.3	106	254
-40	14.1	29.9	85.8	207	19.5	41.9	123	296	—	—	—	—	—	—	—	—	11.3	24.3	70.9	170	15.7	34.0	102	245

EVAPORATOR TEMP. °C	REFRIGERANT																							
	407C								409A								507							
	PRESSURE DROP – bar																							
	0.14				0.28				0.14				0.28				0.14				0.28			
	B5D	8D	12D	16D	B5D	8D	12D	16D	B5D	8D	12D	16D	B5D	8D	12D	16D	B5D	8D	12D	16D	B5D	8D	12D	16D
5	17.6	37.7	109	263	24.5	52.8	157	377	15.1	32.2	92.2	222	21.0	45.1	133	318	14.5	31.1	91.2	219	20.1	43.6	131	314
0	17.3	36.9	107	257	24.0	51.7	154	369	14.8	31.5	90.3	217	20.6	44.2	130	312	14.1	30.4	89.0	214	19.6	42.5	128	307
-5	16.9	36.1	105	252	23.4	50.6	150	361	14.5	30.9	88.4	213	20.1	43.2	127	305	13.8	29.6	86.7	208	19.1	41.4	125	299
-10	16.5	35.3	102	246	22.9	49.4	147	352	14.2	30.2	86.4	208	19.7	42.3	124	298	13.4	28.8	84.4	203	18.6	40.3	121	291
-15	16.1	34.4	99.6	240	22.4	48.2	143	344	13.9	29.5	84.4	203	19.2	41.3	121	291	13.0	28.0	82.0	197	18.1	39.2	118	283
-20	15.7	33.6	97.1	233	21.8	47.0	140	335	13.5	28.8	82.4	198	18.8	40.3	118	284	12.7	27.2	79.6	191	17.6	38.0	114	274
-25	15.3	32.7	94.4	227	21.2	45.7	136	326	13.2	28.1	80.3	193	18.3	39.4	115	277	12.3	26.3	77.1	185	17.0	36.8	111	266
-30	14.9	31.8	91.8	221	20.6	44.5	132	317	—	—	—	—	—	—	—	—	11.9	25.5	74.5	179	16.5	35.6	107	257
-35	14.4	30.8	89.1	214	20.0	43.2	128	307	—	—	—	—	—	—	—	—	11.5	24.6	71.9	173	15.9	34.4	103	248
-40	—	—	—	—	—	—	—	—	—	—	—	—	—	—	—	—	11.0	23.7	69.3	167	15.3	33.2	99.7	239

# 3-WAY HEAT RECLAIM VALVES

22, 134a, 404A, 407C, 409A, 410A, 507

## Specifications – For Refrigerants 22, 134a, 404A, 407C, 409A, 507

MKC-1 COIL						
TYPE	CONNECTION ODF SOLDER Inches	PORT SIZE	MOPD	MAXIMUM RATED PRESSURE bar	STANDARD COIL RATINGS	
			bar		VOLTS/CYCLES	WATTS
5BD5B, 5BD5C	5/8	5/8	20.6	31.0	24/50-60 120/50-60 208-240/50-60 120-208-240/50-60	10
8D7B, 8D7C	7/8	3/4				
8D9B, 8D9C	1-1/8	1-1/4				
12D11B, 12D11C	1-3/8					
12D13B, 12D13C	1-5/8					
12D17B	2-1/8					
16D17B, 16D17C	2-1/8	2				

Available with junction box or conduit boss at no extra charge. For other voltages and cycles, consult your nearest Sporlan Wholesaler or email europe-cold@parker.com.

## Selection

- For a given refrigerant, select a valve having a port size with capacity most closely matching the evaporator maximum load requirements in tons at the design evaporator temperature. Take into account the allowable pressure drop across the valve port.
- Select the proper coil assembly for the valve type and match the voltage requirements. All AC voltage options are available. For voltages not listed in coil specification, consult your nearest Sporlan Wholesaler or email europe-cold@parker.com and request Bulletin 30-10.

## Heat Reclaim Systems with Head Pressure Control with Split Condenser Control with Integral Check Valve

When employing heat reclaim on a refrigeration system, the addition of **head pressure control** is important not only to maintain liquid pressure at the expansion valve inlet, but also to assure availability of quality hot gas at the reclaim heat exchanger.

**Split condenser valves** are important to minimize the required refrigerant charge for wintertime operation.

**3-Way heat reclaim valves with Integral check valves** are important to minimize installation costs.

## Valve Nomenclature/Ordering Instructions

When ordering complete valves, specify Valve Type, Voltage and Cycles. When ordering Valve Body ONLY, specify Valve Type. When ordering Coil Assembly ONLY, specify Coil Type, Voltage and Cycles. **Example: MKC-1 120/50-60; MKC-2 120/50-60.**

<b>MKC</b>	<b>1</b>	<b>120</b>	<b>50-60</b>
Coil Type	Site	Voltage	Cycles

## Specifications – For Refrigerant 410A

VALVE SERIES	TYPE	STANDARD CONNECTION Inches	PORT SIZE	MOPD	MRP	STANDARD COIL RATINGS		
			mm	bar*	bar**	VOLTS/CYCLES	WATTS	COIL
<b>B5D</b>	B5D5B	5/8	16	27.6	44.8	24/50-60 120/50-60 208-240/50-60 120-208-240/50-60	10	MKC-1
	B5D5C							
<b>8D</b>	8D7B-HP	7/8	19	27.6	44.8			
	8D7C-HP							
	8D9B-HP	1-1/8						

\* MOPD stands for Maximum Operating Pressure Differential.

\*\* MRP stands for Maximum Rated Pressure.

- Available with conduit boss, junction box, or DIN at no extra charge.
- Dual voltage 4-wire coils, 120-208-240/50-60 are available at slight additional cost. For other voltages and cycles, consult your nearest Sporlan Wholesaler or email europe-cold@parker.com

## Evaporator Capacities kW (bar) °C

TYPE	EVAPORATOR TEMPERATURE °C	PRESSURE DROP – bar	
		0.15	0.3
<b>B5D</b>	4	20.5	28.4
	0	20.2	28.0
	-5	19.9	27.6
	-10	19.5	27.1
<b>8D</b>	4	44.0	61.5
	0	43.3	60.7
	-5	42.6	59.6
	-10	41.8	58.5

Capacities are based on 38°C condensing temperature isentropic compression plus 28°C, evaporator temperature as shown plus 14°C superheat suction gas. For capacities at other conditions, use the Sporlan Selection Program or contact europe-cold@parker.com. All capacity ratings are in accordance with ARI Standard No. 760-80.

# 10G79B, 10G711B and 10G711C HOT GAS DEFROST 22, 134a, 404A, 507

## Application

Hot gas defrost valves are utilized in systems in which one or more compressors provide refrigeration to multiple refrigerated cases, both medium and low temperature. The 3-way valves are used to control the flow of gas off a discharge header to the various cases (defrost) or suction gas from the cases to the suction header (refrigeration). The direction of flow is dependent upon whether the pilot valve coil is energized or de-energized. These 3-way valves are used for gas defrost only.

When the coil is de-energized, the valve allows the flow of refrigerant in the normal direction for refrigeration. When the valve is



energized the piston and seat assembly shifts to close the suction port and open the discharge gas port, to allow hot gas to flow from the discharge header through the valve to the evaporator outlet.

Due to the fact that when de-energized the valves remain closed to the hot gas connection, these can only be applied off a discharge header and not in the main discharge line.

## Installation and Service

The 10G79B, 10G711B and 10G711C may be installed either upright or on its side. However, it should not be mounted with the coil housing below the valve body. The valve can be soldered in place without disassembly, but the body must be kept cool to avoid damage to the Nylatron synthetic seating material. Body and connections should be wrapped in a wet cloth. The valves may be easily disassembled without unsweating connections.

## Specifications

TYPE	CONNECTIONS ODF SOLDER Inches			MOPD* AC bar	MRP** bar	STANDARD COIL RATINGS		
	DISCHARGE	SUCTION	EVAPORATOR			VOLTS/CYCLES	WATTS	COIL
10G79B	7/8	1-1/8	1-1/8	20.6	34.4	24/50-60 120/50-60 208-240/50-60 120-208-240/50-60	10	MKC-1
10G711B		1-3/8	1-3/8					
10G711C		1-3/8	1-3/8					

\* MOPD stands for Maximum Operating Pressure Differential.

\*\* MRP stands for Maximum Rated Pressure.

Not available for R-410A.

• Available with conduit boss, junction box, or DIN at no extra charge.

• Dual voltage 4-wire coils, 120-208-240/50-60 are available at slight additional cost.

For other voltages and cycles, consult your nearest Sporlan Wholesaler or email [europcold@parker.com](mailto:europcold@parker.com)

## Evaporator Capacities kW • bar • °C

EVAPORATOR TEMPERATURE °C	PRESSURE DROP ACROSS THE VALVE ΔP – bar							
	0.03				0.07			
	22	134a	404A	507	22	134a	404A	507
-5	19.6	14.7	16.5	16.2	29.5	22.1	24.8	24.3
-10	17.7	13.0	14.7	14.4	26.6	19.6	22.1	21.7
-15	15.9	11.5	13.0	12.8	23.9	17.3	19.6	19.3
-20	14.3	10.1	11.5	11.3	21.5	15.2	17.3	17.0
-25	12.7	8.87	10.1	9.98	19.2	13.3	15.2	15.0
-30	11.3	7.72	8.87	8.74	17.1	11.6	13.3	13.2
-35	10.0	6.69	7.72	7.62	15.1	10.1	11.6	11.5
-40	8.83	5.76	6.68	6.60	13.3	8.66	10.0	9.93

Capacities are based on 38°C condensing temperature isentropic compression plus 28°C, evaporator temperature as shown plus 14°C superheat suction gas. For capacities at other conditions, use the Sporlan Selection Program or email [europcold@parker.com](mailto:europcold@parker.com). All capacity ratings are in accordance with ARI Standard No. 760-80.

## Valve Nomenclature/Ordering Instructions

When ordering complete valves, specify Valve Type, Voltage and Cycles. When ordering Valve Body ONLY, specify Valve Type. When ordering Coil Assembly ONLY, specify Coil Type, Voltage and Cycles. **Example: MKC-1 120/50-60.**

<b>MKC</b>	<b>1</b>	<b>120</b>	<b>/</b>	<b>50-60</b>
Coil Type	Size	Voltage		Cycles

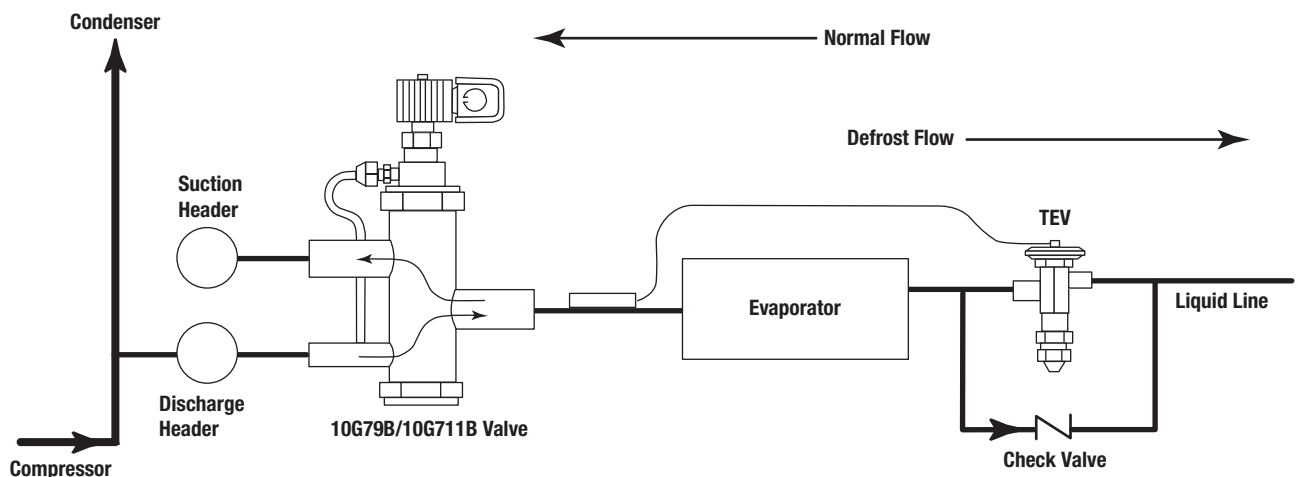





22, 134a, 404A, 407C, 409A, 410A, 507

The universal acceptance of the **Catch-All® Filter-Drier** is due to its unique molded porous core, consisting of a blend of highly effective desiccants. The quality features built into it assure years of service on any refrigeration system.

**MOISTURE** – The **Catch-All Filter-Drier** removes moisture from the refrigerant by adsorbing and retaining it deep within the desiccant granules. The blend of desiccants used in the **Catch-All Filter-Drier** are specially formulated for exceptional water removal.

**FOREIGN MATTER** – The **Catch-All Filter-Drier** will filter out scale, solder particles, carbon, sludge, dirt or any other foreign matter with negligible pressure drop. Fine particles that would go through an ordinary strainer are removed down to a minimum size in one pass filtration. The large filtering area of the **Catch-All Filter-Drier** core permits it to collect a large amount of dirt without plug up.

**ACID** – The **Catch-All Filter-Drier** is unexcelled in acid removal ability. The hydrochloric, hydrofluoric, and various organic

acids are adsorbed and held by the desiccant in a manner similar to the adsorption of moisture. Tests have demonstrated that the **Catch-All Filter-Drier** has superior acid removal ability when compared to competitive driers. This ability, along with its excellent ability to clean up the oil, is responsible for the excellent field performance in cleaning up severely contaminated systems.

**OIL SLUDGE AND VARNISH** – Even the best refrigeration oils break down to produce varnish, sludge and organic acids. Only the **Catch-All Filter-Drier** is capable of removing these products of oil decomposition.

**SPECIAL APPLICATIONS** – A special “HH” core **Catch-All Filter-Drier** is available to remove wax which frequently causes difficulty on low temperature refrigeration systems. For cap tube systems, use the C-032-CAP or C-032-CAP-T Catch-All which has fittings suitable for attaching to any size capillary tube.

*Remember...It's the CORE that counts!*



### Sealed Type – Liquid Line and Suction Line Specifications kW • bar • °C

"C" SERIES LIQUID LINE TYPE		SUCTION LINE TYPE	CONNECTION SIZE Inches	VOLUME of DESICCANT cm <sup>3</sup>	OVERALL LENGTH mm		SOLDER SOCKET DEPTH mm	DIAMETER of BODY mm
SAE FLARE	ODF SOLDER	ODF SOLDER			SAE FLARE	ODF SOLDER		
C-032	C-032-S	—	1/4	49	106	97	10	44
—	C-032-CAP C-032-CAP-T	—	Extended 1/4 Male		—	148	—	
C-032-F	—	—	1/4 Male - Inlet 1/4 Female - Outlet		97	—	—	
C-032-FM	—	—	1/4 Female - Inlet 1/4 Male - Outlet		97	—	—	
C-033	C-033-S	—	3/8		119	99	11	
C-052	C-052-S	—	1/4	82	121	106	10	62
—	C-0525-S	—	5/16		—	111	11	
C-052-F	—	—	1/4 Male - Inlet 1/4 Female - Outlet		106	—	—	
C-052-FM	—	—	1/4 Male - Inlet 1/4 Female - Outlet		106	—	—	
C-053	C-053-S	—	3/8		132	109	11	
C-082	C-082-S	—	1/4	147	143	130	10	67
—	C-0825-S	—	5/16		—	135	11	
C-083	C-083-S	C-083-S-T-HH	3/8		154	133	11	
C-084	C-084-S	C-084-S-T-HH	1/2		160	138	13	
C-162	C-162-S	—	1/4		159	146	10	
—	C-1625-S	—	5/16	—	151	11		
C-163	C-163-S	—	3/8	262	171	149	11	76
C-164	C-164-S	C-164-S-T-HH	1/2		176	152	13	
C-165	C-165-S	C-165-S-T-HH	5/8		184	160	16	
—	—	C-166-S-T-HH	3/4		—	171	16	
—	C-167-S	C-167-S-T-HH	7/8		—	176	19	
C-303	C-303-S	—	3/8	492	246	226	11	76
C-304	C-304-S	—	1/2		251	229	13	
C-305	C-305-S	C-305-S-T-HH	5/8		259	235	16	
—	C-306-S	C-306-S-T-HH	3/4		—	245	16	
—	C-307-S	C-307-S-T-HH	7/8		—	249	19	
—	C-309-S	C-309-S-T-HH	1-1/8	—	248	24		
C-413	—	—	3/8	672	243	—	—	89
C-414	C-414-S	—	1/2		252	230	13	
C-415	C-415-S	—	5/8		260	237	16	
—	C-417-S	C-417-S-T-HH	7/8		—	249	19	
—	C-419-S	C-419-S-T-HH	1-1/8		—	248	24	
—	—	C-437-S-T-HH	7/8	787	—	263	19	121
—	—	C-439-S-T-HH	1-1/8		—	273	24	
—	—	C-4311-S-T-HH	1-3/8		—	278	25	
—	—	C-4313-S-T-HH	1-5/8		—	278	27	
—	C-607-S	C-607-S-T-HH	7/8		983	—	406	
—	C-609-S	C-609-S-T-HH	1-1/8	—		406	24	
<b>COMPACT STYLE</b>		C-144-S-TT-HH	1/2	229	—	105	13	113
		C-145-S-TT-HH	5/8		—	111	16	
		C-146-S-TT-HH	3/4		—	123	18	
		C-147-S-TT-HH	7/8		—	126	19	
		C-149-S-TT-HH	1-1/8		—	125	24	

UL and UL<sub>C</sub> Listed – Guide SMGT-File No. SA-1756A & B. Maximum Rated Pressure of 44.8 bar, except for the C-140 Series rated at 31 bar and the C-430 Series rated at 34.5 bar.

## Replaceable Core Type

### ODF Solder Connections

The rugged construction of the Replaceable Core Catch-All has proven itself in the field for many years. The design features include:

1. The famous **molded porous core** for maximum contaminant removal. The core cannot swell, powder or pack – assuring ease of installation and removal.
2. The **bolt and nut attachment** of the end plate provides simple trouble-free installation.
3. The **internal** construction gives a one piece assembly and assures proper core alignment.
4. A **complete line** of fitting sizes – all with copper fittings.
5. **No plastic parts** are used – all internal parts are plated steel.
6. A **corrosion resistant powder paint** protects the exterior of the shell.



RCW-48



RC-4864-GL



RCW-100



C-969-G



## Specifications

TYPE	CONNECTIONS ODF SOLDER Inches	OPTIONAL SECONDARY FILTER*	NUMBER of CORES or FILTER ELEMENTS	CORE PART NUMBER	VOLUME of DESICCANT cm <sup>3</sup>	FILTER ELEMENT PART NUMBER	MOUNTING BRACKETS	OVERALL LENGTH mm			
C-R424-G	1/2	—	1	RCW-42	688	—	A-175-1	229			
C-R425-G	5/8	—	1	RCW-42	688	—	A-175-1	230			
C-R427-G	7/8	—	1	RCW-42	688	—	A-175-1	240			
C-485-G	5/8	FS-480	1	RC-4864, RC-48GL, RCW-48, or RC-4864-HH	787	RPE-48-BD	A-685	232			
C-487-G	7/8							236			
C-489-G	1-1/8							241			
C-4811-G	1-3/8							244			
C-4813-G	1-5/8							244			
C-967-G	7/8	FS-960	2		RC-4864, RC-48GL, RCW-48, or RC-4864-HH	1573	RPE-48-BD	A-685	377		
C-969-G	1-1/8								382		
C-9611-G	1-3/8								385		
C-9613-G	1-5/8								385		
C-1449-G	1-1/8	FS-1440	3			RC-4864, RC-48GL, RCW-48, or RC-4864-HH	2360	RPE-48-BD	A-685	523	
C-14411-G	1-3/8			525							
C-14413-G	1-5/8			525							
C-19211-G	1-3/8	FS-19200	4	RC-4864, RC-48GL, RCW-48, or RC-4864-HH			3146	RPE-48-BD	A-685	666	
C-19213-G	1-5/8									666	
C-19217-G	2-1/8									666	
C-30013-G	1-5/8	—	3		RCW-100, RC-10098 or RC-10098-HH		4916	RPE-100	A-175-2	710	
C-30017-G	2-1/8									713	
C-40017-G	2-1/8	—	4				RCW-100, RC-10098 or RC-10098-HH	6555	RPE-100	A-175-2	878
C-40021-G	2-5/8										883
C-40025-G	3-1/8					875					
C-40029-G	3-5/8					884					
C-40033-G	4-1/8					892					
NPT PIPE CONNECTIONS											
C-484-PG	1/2	—	1	RC-4864, RC-48GL, RCW-48, or RC-4864-HH		787		RPE-48-BD	A-685	231	
C-966-PG	3/4		2	1572		373					
C-1448-PG	1		3	2360	519						
C-19212-PG	1-1/2		4	3146	657						
C-40016-PG	2	—	4	RCW-100, RC-10098 or RC-10098-HH	6555	RPE-100	A-175-2	875			

UL and UL<sub>C</sub> Listed – Guide SMGT-File No. SA-1756A & B.

Maximum rated pressure of 34.4 bar, except for the Type C-R420 Series which has a maximum rated pressure of 27.5 bar.

\*Optional Secondary Filter must be purchased separately. O-rings (p/n 621-025) are supplied with each secondary filter, but can be purchased separately. The secondary filter cannot be used if the shell is installed in the suction line.

Type numbers with G suffix indicate that unit is supplied with 1/4" female pipe connection in the end plate and pipe plug. For liquid line service an angle charging valve for system charging purposes can be installed in place of the pipe plug. Angle charging and Schrader type access valves are available from your Sporlan Wholesaler.

Type numbers with P suffix indicates female threaded pipe connections.

Ammonia Catch-All Filters prolong the life of ammonia systems by using the Catch-All to effectively remove scale and other solid contaminants. Select a model from those listed above with female pipe connections.

Note: Do not use the RPE-48-BD, RPE-100 filter elements or the RC-48GL core in ammonia systems.





22, 134a, 404A, 407C, 410A, 507

### Liquid Line Ratings and Selection Recommendations

TYPE	ESURFACE FILTERING AREA – cm <sup>2</sup>	WRATINGS AT ARI STANDARD CONDITIONS														SELECTION RECOMMENDATIONS (kW)					
		WATER CAPACITY – DROPS										QREFRIGERANT FLOW CAPACITY kW at 0.07 bar ΔP				REFRIGERATION			AIR CONDITIONING		
		R-22 60 PPM		R-134a 50 PPM		R-404A & 507 50 PPM		R-407C 50 PPM		R-410A 50 PPM						COMMERCIAL & LOW TEMPERATURE EQUIPMENT			FIELD REPLACEMENT or FIELD BUILT UP SYSTEMS		
		25°C	50°C	25°C	50°C	25°C	50°C	25°C	50°C	25°C	50°C	22	134a	404A & 507	407C	410A	134a	22	404A & 507	134a	22, 407C & 410A
<b>SEALED TYPE</b>																					
C-032																					
C-032-CAP																					
C-032-S																					
C-032-F	58	3.1	2.5	3.4	2.4	3.6	2.9	2.6	0.9	1.4	1.0	5.28	4.57	3.52	4.57	4.92	0.88	0.88	0.88	1.76	1.76
C-032-FM																					
C-033												12.3	11.3	8.09	11.3	12.0					
C-033-S												13.4	12.3	9.14	12.3	13.0					
C-052																					
C-052-S												7.39	6.68	4.92	6.68	7.03	1.17	1.17	1.17	2.64 thru 3.52	2.64 thru 7.03
C-052-F																					
C-052-FM	97	7.3	6.0	7.9	5.7	8.5	6.9	6.2	2.0	3.2	2.4										
C-0525-S												12.0	10.9	8.09	10.9	11.6					
C-053												14.4	13.4	9.50	13.4	14.1					
C-053-S												16.5	15.1	10.9	15.1	15.8					
C-082												7.39	6.68	4.92	6.68	7.03	1.76	1.76	1.76	2.64 thru 7.03	3.52 thru 7.03
C-082-S												13.0	11.6	8.44	11.6	12.3					
C-0825-S												15.8	14.8	10.6	14.8	15.5					
C-083	135	12.0	9.8	13.1	9.4	14.0	11.4	10.1	3.3	5.2	3.9	18.3	16.5	12.0	16.5	17.6	5.28	5.28	3.52	7.03	7.03
C-083-S												30.6	27.8	20.7	28.1	29.9					
C-084												33.8	30.9	22.5	30.9	33.1					
C-084-S																					
C-162												7.39	6.68	4.92	6.68	7.03	3.52	5.28	2.64 thru 7.03	3.52 thru 17.6	5.28 thru 17.6
C-162-S												13.0	11.6	8.44	11.6	12.3					
C-1625-S												15.8	14.8	10.6	14.8	15.5					
C-163												18.3	16.5	12.0	16.5	17.6					
C-163-S	213	17.3	14.9	19.8	14.3	21.2	17.3	15.4	5.0	7.9	6.0	35.5	32.7	23.9	32.7	34.2	7.03	10.6	7.03	17.6	17.6
C-164												38.7	35.5	25.7	35.5	37.6					
C-164-S												48.5	44.3	32.4	44.7	47.1					
C-165												55.9	51.0	37.3	51.3	54.5					
C-165-S												16.2	14.8	10.6	14.8	15.5					
C-303												18.6	16.5	12.0	16.5	17.6	10.6	10.6	7.03 thru 17.6	10.6 thru 26.4	14.1 thru 35.2
C-303-S												35.5	32.7	23.9	32.7	34.5					
C-304												52.4	47.8	34.8	48.2	51.0					
C-304-S	342	34.8	28.4	37.8	27.3	40.5	32.9	29.3	9.5	15.1	11.4	59.4	54.5	39.7	54.5	57.7	10.6 thru 17.6	10.6 thru 17.6	7.03 thru 17.6	10.6 thru 26.4	14.1 thru 35.2
C-305												76.0	69.6	50.6	70.0	73.9					
C-305-S												40.5	36.9	26.7	36.9	39.0					
C-307-S												43.6	40.1	29.2	40.1	42.6					
C-414												55.6	51.0	37.3	51.4	54.2	17.6 thru 35.2	17.6 thru 42.2	17.6 thru 35.2	17.6 thru 42.2	26.4 thru 52.8
C-414-S												61.5	56.6	41.5	57.0	60.1					
C-415												77.7	71.4	52.0	71.8	25.6					
C-415-S	432	46.8	35.7	50.9	36.7	54.4	44.3	39.4	12.7	20.4	15.3	85.5	78.4	57.3	78.8	83.4					
C-417-S												102	93.6	68.6	94.3	100					
C-419-S												117	107	78.4	108	114					
C-607-S	684	69.6	56.7	75.6	54.5	80.9	65.8	58.6	18.9	30.2	22.7						52.8	52.8	35.2	52.8	70.3
C-609-S																					

Q Based on 30°C liquid line temperature and a refrigerant flow of 400 grams per minute per kW of Refrigerant 134a; 374 grams per minute per kW of Refrigerant 22; 503 grams per minute per kW for Refrigerant 404A; 375 grams per minute per kW for Refrigerant 407C; 362 grams per minute per kW for Refrigerant 410A and 529 grams per minute per kW for Refrigerant 507. Ratings in accordance to ARI Standard 710.

W 20 drops = 1 gram = 1 cc.

E The filtration area is equal to the core surface area plus the large internal surface available for depth filtration.

Note: The variation in flow ratings of filter-driers having the same size core and shell is caused by the difference in connection sizes used.

### Liquid Line Ratings and Selection Recommendations

TYPE	ESURFACE FILTERING AREA cm <sup>2</sup>	WRATINGS AT ARI STANDARD CONDITIONS										SELECTION RECOMMENDATIONS (kW)				
		WATER CAPACITY – GRAMS						QREFRIGERANT FLOW CAPACITY kW at 0.07 bar ΔP				REFRIGERATION			AIR CONDITIONING	
		R-22 60 PPM		R-134a 50 PPM		R-404A & 507 50 PPM						COMMERCIAL & LOW TEMPERATURE EQUIPMENT			FIELD REPLACEMENT or FIELD BUILT UP SYSTEMS	
		25°C	50°C	25°C	50°C	25°C	50°C	22	134a	404A & 507	134a	22	404A, 502 & 507	134a	22	
<b>REPLACEABLE CORE TYPE WITH STANDARD CORES (See page 36)</b>																
C-485-G	413	17.4	14.4	29.2	23.7	20.4	15.5	51.4	47.1	34.5	26.4	35.2	26.4	26.4	35.2	
C-487-G								84.1	77.0	56.3	42.2	52.8	35.2	42.2	52.8	
C-489-G								152	139	102	52.8	35.2	52.8	70.3		
C-967-G	826	34.7	28.8	58.3	47.3	40.8	30.9	138	126	92.2	70.3	87.9	52.8	70.3	87.9	
C-969-G								171	157	115	87.9	123	87.9	87.9	123	
C-1449-G	1239	52.1	43.2	87.5	71.0	61.2	46.4	208	190	140	106	141	106	106	141	
C-14411-G								236	216	158	141	176	123	141	176	
C-19211-G	1652	69.4	57.6	117	94.6	81.6	61.8	297	272	198	176	246	176	176	246	
C-19213-G								348	319	233	211	281	193	211	281	
C-19217-G								366	335	244	229	299	211	229	299	
C-30013-G	1897	134	93.9	196	151	132	99.6	394	359	262	264	352	246	264	352	
C-40017-G	2529	178	125	261	201	175	133	471	464	340	387	457	352	387	457	

TYPE	ESURFACE FILTERING AREA – cm <sup>2</sup>	WRATINGS AT ARI STANDARD CONDITIONS										SELECTION RECOMMENDATIONS (kW)										
		WATER CAPACITY – GRAMS						QREFRIGERANT FLOW CAPACITY kW at 0.07 bar ΔP				REFRIGERATION			AIR CONDITIONING							
		R-22 60 PPM		R-134a 50 PPM		R-404A & 507 50 PPM						R-407C 50 PPM		R-410A 50 PPM		COMMERCIAL & LOW TEMPERATURE EQUIPMENT			FIELD REPLACEMENT or FIELD BUILT UP SYSTEMS			
		25°C	50°C	25°C	50°C	25°C	50°C	25°C	50°C	25°C	50°C	22	134a	404A & 507	407C	410A	134a	22	404A & 507	134a	22 & 407C	410A
<b>REPLACEABLE CORE TYPE WITH HIGH WATER CAPACITY CORES (See page 36)</b>																						
C-R424-G	432	45.1	36.8	49.1	35.3	52.5	42.7	38	12.3	20.4	15.3	40.1	36.6	26.7	36.9	42.6	10.6	17.6	17.6	17.6	17.6	17.6
C-R425-G												48.2	44.0	32.0	44.0	60.1	17.6	26.4	17.6	26.4	35.2	35.2
C-R427-G												65.1	59.4	43.6	59.8	75.6	26.4	35.2	26.4	26.4	35.2	35.2
C-485-G	413	55.5	45.2	60.1	43.4	64.5	52.5	46.7	15.1	24.1	18.1	51.4	47.1	34.5	47.5	50.3	26.4	35.2	26.4	26.4	35.2	35.2
C-487-G												84.1	77.0	56.3	77.4	81.9	42.2	52.8	35.2	42.2	52.8	52.8
C-489-G												152	139	102	140	14.8	52.8	35.2	52.8	70.3	70.3	
C-967-G	826	111	90.4	120	86.8	129	105	93.4	30.1	48.1	36.1	138	126	92.2	127	135	70.3	87.9	52.8	70.3	87.9	87.9
C-969-G												171	157	115	158	167	87.9	123	87.9	87.9	123	
C-1449-G	1239	166	136	180	130	194	157	140	45.2	72.2	54.2	208	190	140	192	204	106	141	106	106	141	141
C-14411-G												236	216	158	217	230	141	176	123	141	176	176
C-19211-G	1652	222	181	240	174	258	210	187	60.2	96.2	72.2	297	272	198	273	290	176	246	176	176	246	246
C-19213-G												348	319	233	320	340	211	281	193	211	281	281
C-19217-G												366	335	244	337	355	229	299	211	229	299	299
C-30013-G	1897	339	277	369	266	395	321	286	92.2	—	—	394	359	262	362	—	264	352	246	264	352	—
C-40017-G	2529	452	369	492	354	526	428	382	123	—	—	471	464	341	468	—	287	457	352	387	457	—

**Q** Based on 30°C liquid line temperature and a refrigerant flow of 400 grams per minute per kW of Refrigerant 134a; 374 grams per minute per kW of Refrigerant 22; 503 grams per minute per kW for Refrigerant 404A; 375 grams per minute per kW for Refrigerant 407C; 362 grams per minute per kW for Refrigerant 410A and 529 grams per minute per kW for Refrigerant 507. Ratings in accordance to ARI Standard 710.

**W** 20 drops = 1 gram = 1 cc.

**E** The filtration area is equal to the core surface area plus the large internal surface available for depth filtration.

Note: The variation in flow ratings of filter-driers having the same size core and shell is caused by the difference in connection sizes used.



22, 134a, 404A, 407C, 410A, 507

## Suction Line Filter-Drier Ratings for New Systems and Clean-up after Burnout Selection Instructions

Except for the values in bold (R-22/R-407C/R-410A at 5°C; 0.55 bar pressure drop), the flow capacities are rated at the maximum recommended pressure drop for **permanent** installation.

To ensure the suction line filter-drier has ample contaminant removal ability, selection must be based on flow capacity and the amount of desiccant required for system clean-up. The suction line filter-drier must be large enough to adequately remove acid, moisture and solid contaminants without causing nuisance plug-ups. Sizing is especially important for sealed type

suction line filter-driers since they should be sized to clean a small system with one service call.

To reduce the pressure drop through replaceable core shells, substitute cores with filter elements (see page 36) after the system has been cleaned up. The 6171-5 screen should be discarded when cores are replaced with RPE-48-BD elements in RSF shells.

For complete description of the suggested system clean-up procedure, request Bulletin 40-10.

## Suction Line Flow Capacity (kW) – Sealed Type

SEAL TYPE	REFRIGERANT		22					134a			404A				407C	410A
	EVAPORATOR TEMPERATURE		5°C	-5°C	-15°C	-30°C	-40°C	5°C	-5°C	-15°C	-5°C	-15°C	-30°C	-40°C	5°C	5°C
	PRESSURE DROP (bar)		0.21	0.14	0.10	0.07	0.04	0.14	0.10	0.07	0.14	0.10	0.07	0.035	0.21	0.21
C-083-S-T-HH	7.4	3.2	4.6	1.8	0.7	4.5	2.9	1.8	4.2	2.8	1.8	0.7	7.0	9.5		
C-084-S-T-HH	7.4	4.6	3.2	1.8	1.1	4.9	3.2	2.1	4.6	2.8	1.8	1.1	7.4	9.5		
C-144-S-T-HH	7.4	4.6	3.2	1.4	0.7	4.6	2.8	1.8	3.2	2.1	1.1	0.7	7.4	9.5		
C-145-S-T-HH	12.0	7.7	4.9	2.8	1.4	7.4	4.6	2.8	5.6	3.5	2.1	1.1	12.0	16.2		
C-146-S-T-HH	16.9	10.6	7.0	4.2	2.1	10.2	6.3	3.9	7.4	4.9	3.2	1.4	16.9	21.8		
C-147-S-T-HH	18.6	11.6	7.7	4.6	2.5	11.3	7.4	4.6	8.5	5.6	3.2	1.8	18.6	23.9		
C-149-S-T-HH	24.6	15.5	10.2	6.0	3.2	14.8	9.5	5.6	11.3	7.4	4.2	2.1	24.6	31.7		
C-164-S-T-HH	9.5	6.0	3.9	2.5	1.1	6.0	3.9	2.5	5.6	3.5	2.1	1.1	9.5	12.7		
C-165-S-T-HH	11.3	7.0	4.6	2.8	1.4	7.0	4.6	2.8	6.7	4.2	2.5	1.4	11.3	14.8		
C-166-S-T-HH	14.1	8.8	5.6	3.5	1.8	9.1	6.0	3.5	8.4	5.6	3.2	1.8	13.7	18.3		
C-167-S-T-HH	15.8	9.9	6.3	3.9	1.8	9.9	6.3	3.9	9.5	6.0	3.5	1.8	15.5	20.8		
C-305-S-T-HH	12.0	7.4	4.9	2.8	1.4	7.7	4.9	2.8	7.0	4.6	2.8	1.4	12.0	15.5		
C-306-S-T-HH	15.5	9.9	6.3	3.9	1.8	9.9	6.3	3.9	9.5	6.0	3.5	1.8	15.5	20.4		
C-307-S-T-HH	18.6	11.6	7.7	4.6	2.1	12.0	7.7	4.6	11.3	7.0	4.2	2.1	18.6	24.6		
C-309-S-T-HH	20.8	13.0	8.4	5.3	2.5	13.4	8.4	5.3	12.7	8.1	4.9	2.5	20.4	27.1		
C-417-S-T-HH	21.1	13.4	8.8	5.3	2.5	13.4	8.8	5.3	12.7	8.1	4.9	2.5	21.1	27.8		
C-419-S-T-HH	21.8	13.7	8.8	5.3	2.8	14.1	9.1	5.6	13.0	8.4	5.3	2.5	21.5	28.1		
C-437-S-T-HH	28.1	17.6	11.6	7.0	3.5	17.9	11.6	7.4	16.9	10.9	6.7	3.2	27.8	36.6		
C-439-S-T-HH	35.2	22.2	14.4	8.8	4.2	22.5	14.8	8.8	21.1	13.7	8.4	4.2	34.8	46.1		
C-4311-S-T-HH	39.0	24.3	16.2	9.5	4.9	25.0	16.2	9.9	23.6	15.1	9.1	4.6	38.3	50.7		
C-4313-S-T-HH	42.9	26.7	17.6	10.6	5.3	27.4	17.9	10.9	25.7	16.5	10.2	4.9	42.2	55.9		
C-607-S-T-HH	23.6	14.8	9.5	5.6	2.8	14.8	9.5	6.0	14.1	9.1	5.6	2.8	23.2	30.6		
C-609-S-T-HH	26.4	16.5	10.9	6.3	3.2	16.9	10.9	6.7	15.8	10.2	6.3	3.2	26.0	34.5		

## Suction Line Flow Capacity (kW) – Shells with Replaceable Cores

REPLACEABLE CORE TYPE	REFRIGERANT		22					134a			404A & 507				407C		410A	
	EVAPORATOR TEMPERATURE		5°C	5°C	-5°C	-15°C	-30°C	-40°C	5°C	-5°C	-15°C	-5°C	-15°C	-30°C	-40°C	5°C	5°C	
	PRESSURE DROP (bar)		0.21	0.55*	0.14	0.10	0.07	0.035	0.14	0.10	0.07	0.14	0.10	0.07	0.035	0.21	0.55*	0.21
RSF-487-T	35.5	<b>61.6</b>	22.2	14.4	8.8	4.2	22.5	14.8	8.8	21.5	14.1	8.1	4.2	35.2	<b>60.8</b>	44.3	<b>77</b>	
RSF-489-T	42.9	<b>74.2</b>	26.7	17.6	10.6	5.3	27.4	17.9	10.9	25.7	16.9	9.9	4.9	42.2	<b>72.8</b>	53.8	<b>92.8</b>	
RSF-4811-T	52.0	<b>90.0</b>	32.7	21.5	12.7	6.3	33.1	21.8	13.0	31.3	20.4	12.0	6.0	51.4	<b>89.0</b>	65.1	<b>113</b>	
RSF-4813-T	55.9	<b>96.7</b>	35.2	22.9	13.7	6.7	35.5	23.6	14.1	33.8	21.8	12.7	6.3	55.2	<b>95.7</b>	70	<b>121</b>	
RSF-4817-T	60.5	<b>105</b>	38.0	25.0	14.8	7.4	38.7	25.3	15.5	36.6	23.9	13.7	7.0	59.8	<b>103</b>	75.6	<b>131</b>	
RSF-4821-T	65.4	<b>113</b>	40.8	26.7	16.2	8.1	41.9	27.4	16.5	39.4	25.7	15.1	7.7	64.7	<b>111</b>	81.9	<b>142</b>	
RSF-9611-T	83.7	<b>137</b>	55.9	39.0	25.0	13.7	55.1	36.9	23.6	50.7	34.5	21.8	11.6	80.5	<b>132</b>	105	<b>172</b>	
RSF-9613-T	105	<b>172</b>	69.6	48.2	30.6	16.5	68.6	45.7	28.5	63.0	42.9	26.7	14.1	101	<b>166</b>	130	<b>216</b>	
RSF-9617-T	105	<b>172</b>	69.6	48.2	30.6	16.5	68.6	45.7	28.5	63.0	42.9	26.7	14.1	101	<b>166</b>	130	<b>216</b>	
RSF-9621-T	105	<b>178</b>	70.3	48.2	30.6	16.5	68.6	45.7	28.5	63.0	42.9	26.7	14.1	102	<b>175</b>	130	<b>216</b>	
RSF-9625-T	106	<b>183</b>	70.3	48.2	30.6	16.5	68.6	45.7	28.5	63.6	42.9	26.7	14.1	105	<b>179</b>	132	<b>223</b>	
C-30013-G	93.6	<b>162</b>	58.7	38.3	22.9	11.3	59.4	38.7	23.6	56.3	36.2	21.8	10.9	92.5	<b>150</b>	—	—	
C-30017-G	95.0	<b>164</b>	59.4	39.0	23.2	11.6	60.5	39.0	23.9	57.0	36.6	22.2	10.9	93.9	<b>152</b>	—	—	
C-40017-G	116	<b>200</b>	72.5	47.5	28.5	14.0	73.9	47.8	29.2	69.6	45.0	25.3	13.4	114	<b>186</b>	—	—	
C-40021-G thru C-40033-G	116	<b>200</b>	72.5	47.5	28.5	14.0	73.9	47.8	29.2	69.6	45.0	25.3	13.4	114	<b>186</b>	—	—	

\*Denotes TEMPORARY INSTALLATION. Cores for system clean-up; RPE-48-BD or RPE-100 Filter Elements should be installed after clean-up.  
Rated in accordance with ARI Standard 730.  
For a simplified "Quick Selection Guide," request Form 40-109.



## Significance of the Type Number

The letters and numerals in the Catch-All type number each have a significance. The “C” indicates Catch-All. The **FIRST TWO OR THREE DIGITS** indicate cubic inches of desiccant. The **LAST ONE OR TWO DIGITS** indicate fitting size in eighths of an inch. For sealed models, a “-S” following the last digit indicates solder fittings, and **NO LETTER** indicates a flare fitting. Replaceable core models (C-420 and larger) only have solder connections and the “-S” is omitted. Examples are: C-083 is 8 cu. in. and 3/8” flare, C-309-S is 30 cu. in. and 1-1/8” solder, C-19213-G is 192 cu. in. and 1-5/8” solder.

## Replaceable Cores and Pleated Filter Elements – Order Separately

Cores for replaceable core type filter-driers are molded of exactly the same desiccants that are used in the popular sealed filter-driers.

Cores are individually packed in *metal cans*, fully activated and hermetically sealed against moisture and dirt.

Filter Elements are dried and packed in individual sealed metal cans. This method of packaging prevents the element from picking up moisture from the atmosphere.

Detailed *instructions* are printed on each can. Each can contains a “*triple gasket*” consisting of a new end plate gasket, an end plate gasket for certain competitive filter-driers and a core gasket where desired. See the specifications on page 32 for the number of cores required for each type drier.

**RCW-42** – High Water Capacity Core – Order as separate item – Fits ONLY shell type C-R424, C-R425 and C-R427. **Designed specially for use with POE oils.** This core should be used on systems that have a ruptured water cooled condenser, or that have been exposed to the atmosphere, or for some reason have a high amount of moisture in the system.

**RC-4864** – Activated Core – Order as separate item – Fits types C-480 thru C-19200 Series shells and Replaceable Suction Filter (RSF) shells. This is the standard core suitable for most installations in the liquid or suction line applications.

**RCW-48GL** – Activated Core – Order as separate item – Fits types C-480 thru C-19200 Series shells and Replaceable Suction Filter (RSF) shells. Core is similar to the RC-4864, but has been reformulated to be an economical alternative for today’s HFC systems. For liquid and suction line service.

**RCW-48** – High Water Capacity Core – Order as separate item – Fits types C-480 thru C-19200 Series shells and Replaceable Suction Filter (RSF) shells. **Designed specially for use with POE oils.** This core should be used on systems that have a ruptured water cooled condenser, or that have been exposed to the atmosphere, or for some reason have a high amount of moisture in the system.

## HH Style Catch-All for Wax Removal

Small amounts of wax are often a problem on **low temperature systems**. Even well engineered systems frequently contain minute quantities of wax which are sufficient to clog expansion valve screens or cause sticking of the valve. Sporlan has developed a special blend of desiccants including activated charcoal which removes small amounts of wax in the liquid line before this wax can cause trouble at the expansion valve. These Catch-All Filter-Driers have been very successful in correcting trouble jobs in the field.

Select an HH Style Catch-All Filter-Drier if wax problems occur on low temperature systems. In addition to their wax removal ability, these filter-driers will remove all of the other harmful contaminants that the standard filter-driers remove. Listed in the table are various Catch-All models that incorporate the HH style core.

Other suffix letters indicate special qualities. For example:

- “-T” indicates a pressure tap consisting of a Schrader type access valve on the inlet end of the Catch-All.
- “-HH” indicates a charcoal style core for wax removal and clean-up after a hermetic motor burnout.
- “-F” indicates a female flare outlet fitting with a male flare inlet fitting.
- “-FM” indicates a female flare inlet fitting with a male flare outlet fitting.
- “-CAP” indicates a Catch-All particularly designed for installation on capillary tube systems.



**RC-4864-HH** – Activated Charcoal Core – Order as separate item – Fits types C-480 thru C-19200 Series shells and Replaceable Suction Filter (RSF) shells. This core should be used for wax removal on low temperature systems, and for clean-up of systems that have had a hermetic motor burnout.

**RPE-48-BD** – Filter Element – Order as separate item – Fits types C-480 thru C-19200 Series shells and **Replaceable Suction Filter (RSF) shells.** This element should be used in RSF shells installed in the **suction line** to obtain the lowest possible pressure drop. In cleaning up a system after a hermetic motor burnout, cores should be used first. Then after the system is thoroughly clean, this filter element can be installed in the RSF shell.

**RC-10098** – Activated Core – Order as separate item – Fits types C-30000 and C-40000 Series shells. This core has a high water capacity and should be used on all standard liquid and suction line applications.

**RCW-100** – High Water Capacity Core – Order as separate item – Fits types C-30000 and C-40000 Series shells. **Designed specially for use with POE oils.** This core should be used on systems that have a ruptured water cooled condenser, or that have been exposed to the atmosphere, or for some reason have a high amount of moisture in the system.

**RC-10098-HH** – Activated Charcoal Core – Order as separate item – Fits types C-30000 and C-40000 Series shells. This core should be used for wax removal on low temperature systems, and for clean-up of systems that have had a hermetic motor burnout.

**RPE-100** – Filter Element – Order as separate item – Fits types C-30000 and C-40000 Series shells. This filter element should be used in the suction line to obtain the lowest possible pressure drop after cores were used for system clean-up.

TYPE	CONNECTIONS Inches	TYPE	CONNECTIONS Inches
C-052-HH	1/4 SAE Flare	C-303-HH	3/8 SAE Flare
C-082-HH	1/4 SAE Flare	C-304-HH	1/2 SAE Flare
C-083-HH	3/8 SAE Flare	C-304-S-HH	1/2 ODF Solder
C-162-HH	1/4 SAE Flare	C-305-HH	5/8 SAE Flare
C-163-HH	3/8 SAE Flare	C-305-S-HH	5/8 ODF Solder
C-163-S-HH	3/8 ODF Solder	C-414-HH	1/2 SAE Flare
C-164-HH	1/2 SAE Flare	C-415-HH	5/8 SAE Flare
C-164-S-HH	1/2 ODF Solder	C-417-S-HH	7/8 ODF Solder
C-165-HH	5/8 SAE Flare	RC-4864-HH	Replaceable Core
C-165-S-HH	5/8 ODF Solder	RC-10098-HH	

For dimensions, refer to the specifications for standard filter-driers or consult Bulletin 40-10.

**Design Benefits**

- A short overall length for easy installation.
- Drier operates in either flow direction with low pressure drop.
- Proven metal check valves used in construction – no synthetic materials.
- The Sporlan dependable molded core used for maximum filtration ability. When the flow direction reverses, dirt already collected remains in the filter-drier.
- A carefully engineered blend of desiccants for maximum water capacity and acid removal ability. The HPC-160-HH Series also has the HH style core with activated charcoal which offers maximum ability to remove oleoresin and other reactive chemical constituents in the lubricant.
- Same rugged construction as used in the Catch-All®.

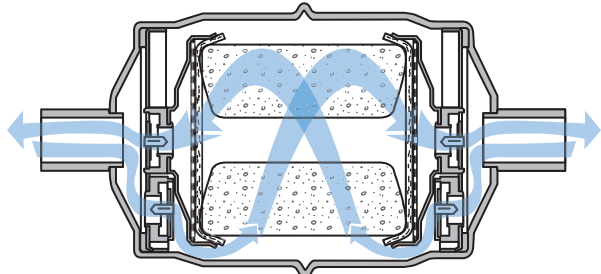

**Specifications – For New Installations**

TYPE NUMBER	CONNECTION SIZE Inches	SELECTION RECOMMEND. kW	DIMENSIONS		SPECIFICATIONS												
			OVERALL LENGTH mm	DIA. mm	FLOW CAPACITY kW @ 0.07 bar ΔP			WATER CAPACITY						LIQUID CAPACITY Grams (wt.) @ 38°C			
					R-22	R-407C	R-410A	R-22 Grams at 60 ppm		R-407C Grams at 50 ppm		R-410A Grams at 50 ppm		R-22	R-407C	R-410A	
24°C	52°C	24°C	52°C	24°C	52°C	24°C	52°C	24°C	52°C	24°C	52°C	24°C	52°C	24°C	52°C		
HPC-103	3/8 Flare	3.5 thru 17.5	171	76	11.9	10.9	11.6	10.8	8.8	9.1	3.0	4.7	3.5	346	304	301	
HPC-103-S	3/8 Solder		149		15.8	14.4	15.4										
HPC-104	1/2 Flare		176														
HPC-104-S	1/2 Solder		152														

**Specifications – For Clean-up after Burnout**

TYPE NUMBER	CONNECTION SIZE Inches	SELECTION RECOMMEND. kW	DIMENSIONS		SPECIFICATIONS																					
			OVERALL LENGTH mm	DIA. mm	FLOW CAPACITY kW @ 0.07 bar ΔP			WATER CAPACITY						LIQUID CAPACITY Grams (wt.) @ 38°C												
					R-22	R-407C	R-410A	R-22 Grams at 60 ppm		R-407C Grams at 50 ppm		R-410A Grams at 50 ppm		R-22	R-407C	R-410A										
24°C	52°C	24°C	52°C	24°C	52°C	24°C	52°C	24°C	52°C	24°C	52°C	24°C	52°C	24°C	52°C											
HPC-163-HH	3/8 SAE Flare	3.5 thru 17.5	198	76	13.0	11.9	12.6	4.7	4.1	4.5	4.4	3.5	5.0	461	360	357										
HPC-163-S-HH	3/8 ODF Solder		176																							
HPC-164-HH	1/2 SAE Flare		202		14.0	13.0	13.7																			
HPC-164-S-HH	1/2 ODF Solder		180		17.2	15.8	16.8																			
HPC-165-HH	5/8 SAE Flare		210																							
HPC-165-S-HH	5/8 ODF Solder	187																								
HPC-303-HH	3/8 SAE Flare	14 thru 42	275	76	17.9	16.5	17.5	8.4	6.0	8.1	4.4	6.2	5.5	559	491	488										
HPC-303-S-HH	3/8 ODF Solder		256																							
HPC-304-HH	1/2 SAE Flare		281		20.7	18.9	20.3																			
HPC-304-S-HH	1/2 ODF Solder		259																							
HPC-305-HH	5/8 SAE Flare		289																							
HPC-305-S-HH	5/8 ODF Solder		265		21.4	19.6	21																			
HPC-307-S-HH	7/8 ODF Solder		280																							

HPC-100 Series – Core volume is 164 cm<sup>3</sup>. Core surface filtering area is 116 cm<sup>2</sup>. Maximum rated pressure is 45 bar.  
 HPC-160-HH Series – Core volume is 229 cm<sup>3</sup>. Core surface filtering area is 168 cm<sup>2</sup>. Maximum rated pressure is 45 bar.  
 HPC-300-HH Series – Core volume is 492 cm<sup>3</sup>. Core filtering area is 342 cm<sup>2</sup>. Maximum rated pressure is 45 bar.  
 UL and UL<sub>C</sub> Listed – Guide-SMGT-File No. SA-1756A & B.



# STEEL SUCTION LINE ACCUMULATORS

## U-Tube Style Accumulators

The U-tube accumulator design is a result of extensive laboratory testing plus detailed investigation of the various accumulators currently available. It takes into account essential requirements such as safe holding volume (relative to the system's total charge), protected flow control for positive refrigerant and oil return, and minimum pressure drop across the accumulator.

Sporlan offers standard accumulator models designed for application on heat pump and refrigeration systems from 0.88 through 42.2 kW. Liquid refrigerant holding requirements of suction accumulator may vary by application. Because of the diversity in systems, optimum performance should be determined by the system designer. Consult Sporlan for assistance if required.

## Features and Benefits

- Solid copper connections
- U-tube design for maximum flow of refrigerant and minimum oil entrapment
- Inlet flow deflector guides refrigerant toward wall for smooth tangential flow and gradual expansion
- U-tube entrance is positioned behind the inlet flow deflector to prevent unwanted liquid refrigerant from entering and damaging compressor
- Metering orifice matched to system capacity assures optimum liquid refrigerant and oil flow back to compressor
- Protective screen and orifice assembly on U-tube protects against contaminants affecting metering function
- Fittings and U-tube are matched to accumulator holding capacity and total system charge for minimum pressure drop and maximum refrigerant flow
- U.L. listed for 24.5 bar maximum working pressure. File No. SA5172
- Powder coating surpasses 500 hour ASTM salt spray
- Integral 221°C fuse plugs (U.L. File No. SA5441)



**Model PA6**

## Dimensions and Flow Data

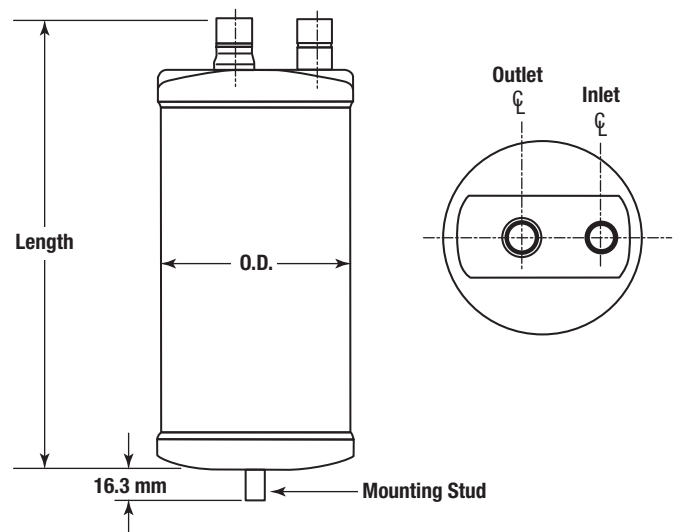

# STEEL SUCTION LINE ACCUMULATORS

22, 134a, 404A, 407C, 409A, 410A, 507

## Dimensions and Flow Data

MODEL NUMBER	CONN. Inches (ODF)	DIMENSIONS mm		CAPACITY* Grams (wt.)	EVAP. TEMP. °C	RECOMMENDED CAPACITY IN kW OF REFRIGERATION									
		LENGTH	O.D.			22 & 404A		134a & 409A		407C		410A		507	
						kW @ .07 bar	Min. kW	kW @ .07 bar	Min. kW	kW @ .07 bar	Min. kW	kW @ .07 bar	Min. kW	kW @ .07 bar	Min. kW
PA3060-10-4 PA3060-10-5	1/2 5/8	263 263	76 76	992 992	5	7.03	1.23	5.87	1.06	6.93	1.62	6.79	5.06	5.21	0.95
					-18	5.42	0.88	3.45	0.56	5.38	0.63	5.28	2.29	3.87	0.70
					-29	4.68	0.74	2.43	0.39	4.64	0.39	4.57	1.48	3.27	0.56
PA3060-15-5	5/8	382	76	1559	5	7.39	1.23	6.15	1.06	7.28	1.62	7.10	5.06	5.45	0.95
					-18	5.70	0.88	3.62	0.56	5.63	0.63	5.52	2.29	4.08	0.70
					-29	4.92	0.74	2.57	0.39	4.89	0.39	4.78	1.48	3.45	0.56
PA3060-15-6	3/4	382	76	1531	5	8.09	1.23	6.75	1.06	7.98	1.62	7.81	5.06	5.98	0.95
					-18	6.23	0.88	3.94	0.56	6.15	0.63	6.05	2.29	4.47	0.70
					-29	5.38	0.74	2.81	0.39	5.35	0.39	5.24	1.48	3.76	0.56
PA4065-9-5C	5/8	244	102	1701	5	10.41	1.23	8.69	1.06	10.27	1.62	10.02	5.06	7.70	0.95
					-18	8.02	0.88	5.06	0.56	7.95	0.63	7.77	2.29	5.73	0.70
					-29	6.96	0.74	3.62	0.39	6.89	0.39	6.79	1.48	4.89	0.56
PA4065-9-6C	3/4	244	102	1644	5	10.55	1.23	8.90	1.06	10.41	1.62	10.16	5.06	7.74	0.98
					-18	8.09	0.88	5.21	0.56	8.02	0.63	7.84	2.29	5.98	0.70
					-29	7.03	0.74	3.69	0.39	6.96	0.39	6.86	1.48	4.92	0.56
PA5083-9-6C	3/4	244	127	2523	5	13.43	2.01	11.22	1.72	13.26	2.43	12.94	7.60	9.92	1.62
					-18	10.37	1.44	6.54	0.95	10.27	0.95	10.06	3.45	7.39	1.16
					-29	8.97	1.23	4.64	0.63	8.90	0.56	8.72	2.22	6.30	0.95
PA5083-9-7C	7/8	245	127	2438	5	13.72	2.01	11.29	1.72	13.54	2.43	13.22	7.60	9.85	1.62
					-18	10.55	1.44	6.61	0.95	10.45	0.95	10.23	3.45	7.39	1.16
					-29	9.14	1.23	4.68	0.63	9.07	0.56	8.90	2.22	6.33	0.95
PA5083-12-7C	7/8	327	127	3544	5	19.03	3.10	15.86	2.64	18.78	3.38	18.32	10.66	14.07	2.46
					-18	14.67	2.25	9.28	1.48	14.52	1.34	14.24	4.82	10.48	1.79
					-29	12.70	1.90	6.58	0.98	12.59	0.77	12.38	3.10	8.90	1.44
PA5083-11-7C	7/8	288	127	3062	5	15.40	2.01	11.29	1.51	15.19	2.43	14.84	7.60	11.36	1.62
					-18	11.85	1.44	6.61	0.84	11.75	0.95	11.50	3.45	8.48	1.16
					-29	10.27	1.23	4.68	0.56	10.16	0.56	9.99	2.22	7.17	0.95
PA5083-11-6C	3/4	288	127	3147	5	13.54	2.01	11.29	1.72	13.36	2.43	13.05	7.60	9.99	1.62
					-18	10.45	1.44	6.61	0.95	10.34	0.95	10.13	3.45	7.46	1.16
					-29	9.00	1.23	4.68	0.63	8.93	0.56	8.76	2.22	6.33	0.95
PA5083-15-7C	7/8	390	127	4423	5	21.80	3.10	18.18	2.64	21.52	3.38	21.00	10.66	16.11	2.46
					-18	16.81	2.25	10.66	1.48	16.63	1.34	16.32	4.82	11.99	1.79
					-29	14.52	1.90	7.56	0.98	14.38	0.77	14.14	3.10	10.20	1.44
PA5083-17-7C	7/8	438	127	5075	5	21.80	3.10	18.18	2.64	21.52	3.38	21.00	10.66	16.11	2.46
					-18	16.81	2.25	10.66	1.48	16.63	1.34	16.32	4.82	11.99	1.79
					-29	14.52	1.90	7.56	0.98	14.38	0.77	14.14	3.10	10.20	1.44
PA6125-15-9C	1-1/8	381	152	5982	5	31.65	10.55	31.05	6.93	31.23	5.52	30.49	17.34	25.67	10.55
					-18	19.69	7.03	19.76	2.88	19.52	2.18	19.13	7.84	15.83	7.03
					-29	15.12	2.81	15.16	1.76	14.98	1.27	14.74	5.03	11.96	2.81
PA6125-15-11C	1-3/8	387	152	6067	5	42.20	10.55	42.38	6.93	41.67	5.52	40.65	17.34	34.47	10.55
					-18	26.38	7.03	26.45	2.88	26.13	2.18	25.60	7.84	21.10	7.03
					-29	20.40	2.81	20.47	1.76	20.22	1.27	19.87	5.03	16.18	2.81
PA6125-18-9C	1-1/8	457	152	7484	5	30.95	10.55	31.09	6.93	30.56	5.52	29.82	17.34	25.32	10.55
					-18	19.34	7.03	19.41	2.88	19.17	2.18	18.78	7.84	15.47	7.03
					-29	15.12	2.81	15.16	1.76	14.98	1.27	14.74	5.03	11.96	2.81
PA6125-18-11C	1-3/8	457	152	7569	5	38.69	10.55	38.86	6.93	38.19	5.52	37.24	17.34	32.00	10.55
					-18	24.62	7.03	24.69	2.88	24.37	2.18	23.91	7.84	19.34	7.03
					-29	18.99	2.81	19.06	1.76	18.82	1.27	18.50	5.03	14.77	2.81
PA6125-20-11C	1-3/8	508	152	8562	5	38.69	10.55	38.86	6.93	38.19	5.52	37.24	17.34	32.00	10.55
					-18	24.62	7.03	24.69	2.88	24.37	2.18	23.91	7.84	19.34	7.03
					-29	18.99	2.81	19.06	1.76	18.82	1.27	18.50	5.03	14.77	2.81

\*Holding capacity of R-22 at 5°C. Divide by 0.7 to obtain recommended maximum system charge on fixed orifice systems. Consult Sporlan for availability.



# STEEL SUCTION LINE ACCUMULATORS

## Features and Benefits

- Designed for refrigerant storage during normal operation and system pump down
- Allows the system to adjust to varying system conditions and loads
- Available in 4", 5" and 6" diameters (2-1/2" and 3" diameter vertical and horizontal receiver models available) – consult Sporlan
- Available up to 36 inches (90 cm) in length
- Integral 220°C fuse plug
- Available options: sightglasses, moisture indicators, float balls, valves, mounting brackets, belly bands, relief valve ports
- Valve is shipped unassembled
- PTFE gasket seal for valve



**Model PR6**

UL file number SA5195 and CSA file number LR46423

- Powder coating surpasses 500 hour ASTM salt spray

MODEL NUMBER	DIAMETER cm	INLET FITTING	OUTLET FITTING	OVERALL LENGTH cm	HOLDING CAPACITY
PR4095-10-2	10.2	1/4 SAE Flare	1/4 SAE Flare	25.4	1.8 kg
PR4095-10-2C		1/4 ODF Solder	1/4 ODF Solder		
PR5109-10-2	12.7	1/4 SAE Flare	1/4 SAE Flare	25.4	2.7 kg
PR5109-10-2C		1/4 ODF Solder	1/4 ODF Solder		
PR5109-10-3	12.7	3/8 SAE Flare	3/8 SAE Flare	25.4	2.7 kg
PR5109-10-3C		3/8 ODF Solder	3/8 ODF Solder		
PR6125-12-3	15.2	3/8 SAE Flare	3/8 SAE Flare	30.5	4.5 kg
PR6125-12-3C		3/8 ODF Solder	3/8 ODF Solder		
PR6125-18-4	15.2	1/2 SAE Flare	1/2 SAE Flare	45.7	7.3 kg
PR6125-18-4C		1/2 ODF Solder	1/2 ODF Solder		

Holding capacity calculated at 90% system charge at 32°C for R-134a, R-22 and R-407C. For R-404A and R-507 multiply by 0.9. Consult Sporlan for R-410A applications. Steel Receivers have a 35 bar M.R.P.

For complete information consult your nearest Sporlan Wholesaler or email [europesold@parker.com](mailto:europesold@parker.com) and request Bulletin 40-10-6.

# ACID TEST KITS – TYPE TA-1 and AK-3

## Designed to Test Mineral, Alkylbenzene and POE Lubricants

- Thoroughly field proven
- Takes the guesswork out of service work

**TA-1**



## Design Benefits

- **Builds Customer Confidence** – Show the test results of the acid test kit to customers, or perform the test in their presence. In this way they realize you are using the most up-to-date scientific method for system maintenance. Showing customers the test results will also help to convince them to spend the money necessary to do a proper clean-up job. Customers who are thoroughly confident of your abilities will be more interested in establishing preventive maintenance programs.
- **Accurate and Reliable** – Using a simple, scientific method, you can precisely measure the amount of acid in a lubricant sample taken from a contaminated system. The test procedure has been proven by extensive field experience.

- **Convenient** – Both the TA-1 and AK-3 are convenient to use. The TA-1 has pre-measured solutions supplied in bottles with screw caps for easy handling. The AK-3 has all solutions and bottles supplied in a small fitted case. Either kit may be used on the job site, or a lubricant sample can be saved and tested in the presence of the equipment owner.
- **Lubricant Sample Used for Test** – Since lubricant is the scavenger, it gives the best indication of acid in the system. Less than an ounce of lubricant is required.
- **Quick to Use** – Once the lubricant sample is obtained...it will take only minutes to perform the test. Simply mix the solutions and lubricant to be tested. Shake, and the resulting color tells the complete story.
- **Cost** – The cost of the test is very inexpensive, regardless of which kit is used. The TA-1 Kit is more convenient, but for repeated testing the AK-3 is less costly.

Both the TA-1 and AK-3 Kits are normally used on a “pass or fail” basis. If the user desires an indication of the relative **amount** of acid in the lubricant, then the AK-3 Kit should be selected.

For complete information consult your nearest Sporlan Wholesaler or email [europesold@parker.com](mailto:europesold@parker.com) and request Bulletin 40-10.



MOISTURE AND LIQUID INDICATOR

## 8 Outstanding Benefits

- One Indicator for Refrigerants 134a, 22, 404A, 407C, 410A, 502 and 507.** The **See•All Moisture and Liquid Indicator** provides a true moisture indication for Refrigerants 134a, 22, 404A, 407C, 410A and 507. The **See•All** is also suitable for Refrigerant 409A. The dark green indicates dry and a bright yellow indicates wet. The one indicator avoids the confusion found in models with two elements. You **cannot** pick the wrong element when checking the moisture content of the system.
- Reliable and Accurately calibrated color change points.** The **See•All Moisture and Liquid Indicator** is accurately calibrated in parts per million of moisture for each refrigerant. All moisture indicators change color on the basis of relative saturation of the refrigerant. Therefore, liquid line temperature must be considered if an accurate calibration is to be obtained. For easy comparison, a color chart is part of the label.
- Color Changes are easily distinguished and reversible.** The indicator's color differs so widely between WET and DRY conditions that there is no possibility of confusion between the two. Colors will reverse as often as moisture concentration in the system changes.
- Large full view sightglass.** The **See•All Moisture and Liquid Indicator** has an extra large crystal clear sightglass for viewing the refrigerant. Bubbles indicate a shortage of refrigerants or a restriction in the liquid line.
- Indicator protected from discoloration and dirt.** The indicator is protected by a filter pad and screen. This prevents washing of the indicator by the refrigerant and protects it from system contamination and turbulence.
- Replaceable indicator element.** The color indicator paper can be changed on the new fused glass models without removing the **See•All** from the line. Replacement is through the bottom (see SA-14SU below). Request the K-SA-4 kit.
- Disassembly of the smaller sizes not required.** The extended steel fittings on solder models in the smaller sizes make it unnecessary to disassemble for installation since steel conducts only one eighth as much heat as copper.
- A double duty plastic cap** is supplied to keep the glass free from dust, dirt and grease. It also permits the service engineer to use his own discretion concerning instructions to his customers on observing the **See•All Moisture and Liquid Indicator**.

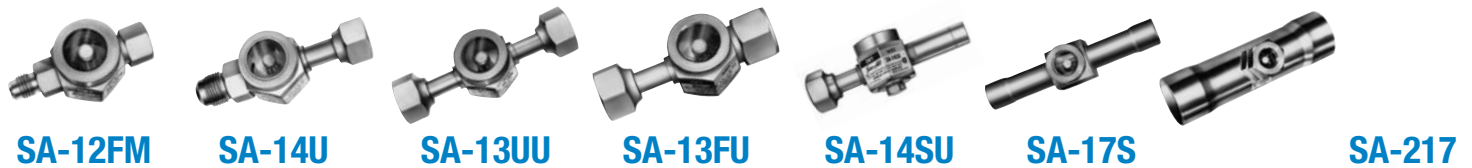

## Specifications

CONNECTION SIZES Inches	MALE FLARE		FEMALE & MALE FLARE		MALE FLARE x SWIVEL NUT		SWIVEL NUT x SWIVEL NUT		FEMALE FLARE x SWIVEL NUT		SWIVEL NUT x ODF SOLDER		ODF SOLDER	
	TYPE NO.	OVERALL LENGTH mm	TYPE NO.	OVERALL LENGTH mm	TYPE NO.	OVERALL LENGTH mm	TYPE NO.	OVERALL LENGTH mm	TYPE NO.	OVERALL LENGTH mm	TYPE NO.	OVERALL LENGTH mm	TYPE NO.	OVERALL LENGTH mm
1/4	SA-12	73	SA-12FM	65	—	—	—	—	—	—	—	—	SA-12S	—
3/8	SA-13	86	SA-13FM	75	SA-13U	92	SA-13UU	100	SA-13FU	81	SA-13SU	106	SA-13S	117
1/2	SA-14	97	SA-14FM	87	SA-14U	105	SA-14UU	114	SA-14FU	95	SA-14SU	117	SA-14S	124
5/8	SA-15	105	—	—	SA-15U	113	SA-15UU	121	—	—	SA-15SU	124	SA-15S	—
7/8	—	—	—	—	—	—	—	—	—	—	—	—	SA-17S	160
1-1/8	—	—	—	—	—	—	—	—	—	—	—	—	SA-19S	—
1-3/8	—	—	—	—	—	—	—	—	—	—	—	—	QSA-211	—
1-5/8	—	—	—	—	—	—	—	—	—	—	—	—	QSA-213	202
2-1/8	—	—	—	—	—	—	—	—	—	—	—	—	QSA-217	—

UL and ULc Listed - Guide SEYW-File No. SA3182

Maximum Rated Pressure for all models is 45 bar. Overall width is: 33 mm for 1/4" and 3/8" sizes, 40 mm for 1/2" and 5/8" sizes, and 35 mm for 7/8" and 1-1/8" sizes. Most solder connections can be used as male fittings as well as female fittings. The 1/4" ODF is 3/8" ODM, the 3/8" ODF is 1/2" ODM, the 1/2" ODF is 5/8" ODM, and the 5/8" ODF is 3/4" ODM. Models with female flare and/or swivel nut connections are supplied with a copper gasket in the fitting.

Q These models have copper connections and feature a removable element cartridge – for replacement cartridge specify AC-20.

## Moisture Content PPM

SEE•ALL SHOWS	LIQUID LINE TEMP.	R-22		R-134a		R-404A & R-507		R-407C	R-410A
		25°C	40°C	25°C	40°C	25°C	40°C	25°C	25°C
<b>Green DRY</b>		Below 30	Below 45	Below 50	Below 80	Below 15	Below 30	Below 120	Below 75
<b>Chartreuse CAUTION</b>		30-90	45-130	50-200	80-225	15-90	30-140	120-280	75-150
<b>Yellow WET</b>		Above 90	Above 130	Above 200	Above 225	Above 90	Above 140	Above 280	Above 150

Note: Change or add Catch-All Filter-Drier when paper turns from green to chartreuse.

# Suction Filters WITH THE OPTIONAL RELIEF FEATURE

## Design Benefits

- Protects the compressor from dirt
- A relief device opens if the filter plugs
- Suitable for use with all brazing alloys
- Maximum corrosion resistance
- Full flow design for low pressure drop
- Complete line of sizes



SF-287-T

Sporlan offers an exclusive concept in Suction Filter design – a filter with an optional relief feature. When flow is in **one direction**, the bypass relief feature is active. If the pressure drop across the element becomes excessive the bypass relief will open slightly to maintain sufficient gas flow and assure proper cooling of the hermetic motor.

When the Suction Filter is installed with flow in the **opposite direction**, the bypass relief feature is inactive and will never open, regardless of the increase in pressure drop.

The “-T” in the type number indicates that these models are equipped with an access valve to permit pressure drop readings. The access valve will be operational provided the Suction Filters are installed with the bypass feature inactive.

TYPE		CONNECTIONS Inches	FILTER AREA cm <sup>2</sup>	DIMENSIONS - mm		
WITHOUT Access Valve	WITH Access Valve			OVERALL LENGTH	SOCKET DEPTH	SHELL DIAMETER
<b>Types with bypass relief feature (Bi-directional Flow)</b>						
SF-283F	—	3/8 SAE Flare	181	223	—	76
—	SF-285-T	5/8 ODF Solder		212	16	
—	SF-286-T	3/4 ODF Solder		223	18	
—	SF-287-T	7/8 ODF Solder		227	19	
—	SF-289-T	1-1/8 ODF Solder		242	23	
—	SF-489-T	1-1/8 ODF Solder	310	315	23	
—	SF-4811-T	1-3/8 ODF Solder		333	25	
—	SF-4813-T	1-5/8 ODF Solder		341	28	
<b>Types without bypass relief feature (Single Flow Direction)</b>						
SF-114	—	1/2 ODF Solder	71	111	13	51
SF-114F	—	1/2 SAE Flare		133	—	
SF-115	—	5/8 ODF Solder		117	16	
SF-115F	—	5/8 SAE Flare		141	—	
—	SF-6417-T	2-1/8 ODF Solder	2503	278	31	121
—	SF-6421-T	2-5/8 ODF Solder		35	35	



Listed by Underwriters' Laboratories, Inc. – Guide SMT – File No. SA-1756A & B.

## Selection Recommendations

TYPE NUMBER		CONNECTIONS Inches	FLOW CAPACITY IN kW EVAPORATOR TEMPERATURE												NOMINAL SYSTEM HORSEPOWER		
WITHOUT Access Valve	WITH Access Valve		5°C		-5°C		-20°C		-30C		-40°C						
			PRESSURE DROP – bar						REFRIGERANT								
			0.20	0.14	0.20	0.14	0.10	0.14	0.10	0.07	0.10	0.07	0.03	22, 407C	134a, 404A, 409A, 507		
SF-114	—	1/2 ODF	8.4	5.3	8.4	5.3	3.5	5.3	3.9	2.1	3.5	2.5	2.1	1.1	1.1	1	1/2
SF-114F	—	1/2 SAE	7.4	4.6	7.4	4.9	3.2	4.6	3.2	1.8	3.2	2.1	1.8	1.1	1.1	1	1/2
SF-115	—	5/8 ODF	14.4	9.1	14.4	9.5	6.0	9.1	6.3	3.9	6.0	4.2	3.9	2.1	2.1	2	1
SF-115-F	—	5/8 SAE	13.0	8.1	13.0	8.4	5.3	8.1	5.6	3.2	5.3	3.5	3.2	1.8	1.8	2	1
SF-283F	—	3/8 SAE	7.4	4.2	7.0	4.6	2.8	4.2	3.2	1.8	2.8	1.4	1.8	1.1	1.1	1	1/2
—	SF-285-T	5/8 ODF	22.5	14.1	21.8	14.1	9.5	13.7	10.2	6.0	9.5	6.3	6.0	3.5	3.2	4	1-1/2
—	SF-286-T	3/4 ODF	30.2	17.9	28.5	17.6	12.0	17.9	12.7	7.4	12.0	7.7	7.4	4.2	3.9	5	1-1/2
—	SF-287-T	7/8 ODF	39.0	24.6	39.7	25.3	16.2	24.6	17.9	9.8	16.2	10.9	10.2	5.3	5.3	7-1/2	3
—	SF-289-T	1-1/8 ODF	52.1	32.4	51.3	33.1	21.1	32.4	23.2	13.0	21.5	14.1	13.4	7.4	7.0	7-1/2	5
—	SF-489-T	1-1/8 ODF	56.3	34.8	55.2	35.2	22.9	34.5	24.6	13.7	22.9	15.1	14.4	7.7	7.4	10	5
—	SF-4811-T	1-3/8 ODF	64.7	39.4	63.3	40.1	25.7	39.4	27.8	15.5	26.0	16.9	16.2	8.8	8.4	12	5
—	SF-4813-T	1-5/8 ODF	76.0	46.8	74.9	47.5	30.6	46.8	33.1	18.3	30.6	19.7	19.0	10.2	9.8	15	7
—	SF-6417-T	2-1/8 ODF	32.0	17.9	31.3	20.0	10.9	18.5	12.5	57.7	11.2	71.4	62.6	32.7	27.8	55	20
—	SF-6421-T	2-5/8 ODF	41.9	22.1	38.3	24.7	13.6	22.7	15.5	72.5	13.9	90.0	78.4	41.5	35.2	60	30

Notes: Maximum rated pressure for SF-11, SF-28 and SF-48 is 27.5 bar. The SF-64 series is rated for 34.5 bar. All ratings are in accordance with ARI Standard 730.

# REPLACEABLE *Suction Filters*

The Replaceable Suction Filter shell, used with RPE-48-BD pleated filter element, is designed to be installed in the suction line of new systems to remove circulating contaminants.

## Design Benefits

- High flow capacity
- Corrosion resistant coating on shell
- Can be used with desiccant cores for clean-up after burnout
- Various fitting sizes up to 3-1/8" line size
- Access valve supplied for pressure drop measurement or charging

## How It's Used

Sporlan Replaceable Suction Filters are installed in the suction line of refrigeration or air conditioning systems to remove

contaminants that may be in the system at startup.

The Replaceable Suction Filter has large fittings permitting the use of a small shell on a system with large line sizes, resulting in considerable economy. The angle construction is suitable of flow in either direction, which results in easy installation even on compact racks.



**RSF-4817-T**

The Replaceable Suction Filters should be used with cores for cleaning up a system after a hermetic motor burnout. Select the RC-4864, RC-4864-HH or RCW-48 replaceable cores. After cleanup, install RPE-48-BD elements in the shells.

## Selection

The table below gives information for choosing the proper model for a given system. The filter elements are supplied in hermetically sealed metal cans.

**For flow capacity WITH CORES, see page 35.**

TYPE	CONNECTIONS Inches ODF SOLDER	FLOW CAPACITY IN kW														NUMBER OF FILTER ELEMENTS	FILTER AREA cm <sup>2</sup>	OVERALL LENGTH mm		
		EVAPORATOR TEMPERATURE																		
		5°C				-5°C				-20°C				-30°C					-40°C	
		PRESSURE DROP – bar																		
		0.21	0.14	0.21	0.21	0.14	0.10	0.14	0.10	0.07	0.10	0.07	0.04	0.07	0.04				0.04	
REFRIGERANT																				
		22	134a	407C	410A	22	134a	404A	22	134a	404A	22	134a	404A	22	404A				
RSF-487-T	7/8	42.2	24.6	38.7	48.5	24.6	17.6	24.6	17.6	10.6	14.1	10.6	3.52	10.6	3.52	3.52	One RPE-48-BD	2503	236	
RSF-489-T	1-1/8	73.9	38.7	63.3	77.4	45.7	24.6	38.7	31.7	14.1	24.6	17.6	7.03	14.1	10.6	7.03			238	
RSF-4811-T	1-3/8	95.0	56.3	91.4	113	59.8	35.2	56.3	38.7	21.1	35.2	24.6	10.6	21.1	10.6	10.6			244	
RSF-4813-T	1-5/8	116	70.3	116	144	73.9	45.7	70.3	49.2	28.1	45.7	28.1	14.1	28.1	14.1	14.1			248	
RSF-4817-T	2-1/8	155	95.0	155	193	98.5	59.8	95.0	63.3	35.2	59.8	38.7	21.1	38.7	17.6	17.6			238	
RSF-4821-T	2-5/8	204	123	204	253	127	80.9	123	84.4	45.7	80.9	49.2	24.6	49.2	24.6	24.6	248			
RSF-9611-T	1-3/8	106	63.3	102	127	70.3	49.2	63.3	49.7	28.1	42.2	31.7	10.6	28.1	17.6	14.1	Two RPE-48-BD	5006	385	
RSF-9613-T	1-5/8	141	77.4	134	165	95.0	63.3	84.4	66.8	38.7	56.3	42.2	17.6	35.2	24.6	21.1			385	
RSF-9617-T	2-1/8	169	102	165	207	106	66.8	102	70.3	38.7	63.3	45.7	21.1	38.7	24.6	24.6			380	
RSF-9621-T	2-5/8	229	141	229	285	144	91.4	141	95.0	52.8	91.4	56.3	28.1	56.3	28.1	28.1			392	
RSF-9625-T	3-1/8	317	193	313	390	200	123	193	130	70.3	123	87.9	42.2	77.4	38.7	35.2			384	

Listed by Underwriters' Laboratories, Inc. Guide SMGT File No. SA-1756A & B. RSF shells have a 34.5 bar M.R.P. rating.

Note: Use R-404A ratings for R-507.

Ratings are in accordance with ARI Standards 730. Flow capacity (kW) with cores is approximately 40% of the above values.

# DISCHARGE BYPASS VALVES

**SHGB-15**



**ADRI**



**ADRHE-6**



**DRHE-6**

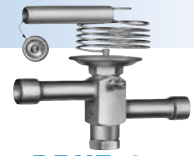

LISTED or Recognized

The Sporlan line of discharge bypass valves are designed to provide an economical method of compressor capacity control in place of cylinder unloaders or to handle unloading requirements below the last step of cylinder unloading. These modulating control valves automatically bypass the required amount of discharge gas to the low side to maintain the desired minimum evaporator pressure. The valves are applicable on any refrigeration or air conditioning system that operates during periods of low load, which can result in coil icing or short cycling. These valves respond to downstream pressure changes and open when the evaporator pressure falls below the valve setting. At normal loads and evaporator conditions, the valve remains closed and the system operates in a conventional manner.

**The DR line of valves consists of three basic types of valves: the adjustable models, the adjustable remote bulb models, and the non-adjustable models (contact Sporlan for information).**

**The SHGB valves are adjustable and pilot operated with a solenoid stop feature that eliminates the need for a hot gas solenoid valve. They were developed for use on larger capacity systems.**

## Application

The discharge bypass valve is normally applied in a branch line off the discharge line. To allow system pump down control, a solenoid valve or hand valve must be installed upstream of the discharge DR type bypass valves. The bypassed hot gas can enter the low side at several locations; however, two of the possible locations are preferred because of superior operating performance: into the side connection of a Sporlan side connection distributor or directly into the suction line. By using the side connection distributor method, the system TEV will act as a desuperheating valve to keep the compressor suction

temperature below the recommended maximum temperature published by the compressor manufacturer. When the hot gas is bypassed directly into the suction line, an auxiliary desuperheating TEV may be required. See Bulletin 90-40 and 90-40-1 for complete application details.

## Selection and Capacity Ratings

The capacities given in the table below are **valve** hot gas capacities and not the capacities of the system on which the valve is to be applied. To select a valve, first determine the compressor capacity at the minimum allowable evaporating temperature. Then the discharge bypass valve must supply the difference between this compressor capacity and the minimum evaporator load at which the system is to be operated. The valve pressure setting will be that pressure at which the bypass valve must start to open.

Connections – (Standard Connections are in **BOLD** type. Non-standard connections may be subject to availability and/or require a minimum quantity).

- ADRI(E)-1-1/4, - 3/8"** ODF Solder
- ADRS(E)-2 - 3/8", 1/2", 5/8"** ODF Solder or 3/8", 1/2", 5/8" SAE Flare
- ADRP(E)-3 - 1/2", 5/8"**, ODF Solder or 1/2", 5/8" SAE Flare
- ADRHE-6 & DRHE-6 - 5/8", 7/8", 1-1/8"** ODF Solder
- SHGB(E)-8 - 7/8"** ODF, 1-1/8" ODF Solder
- SHGB(E)-15 - 1-1/8", 1-3/8"** ODF Solder
- HGB(E)-5 - 3/8, 1/2, 5/8** ODF Solder
- HGB(E)-8 - 7/8, 1-1/8** ODF Solder

Note: Refer to Bulletin R-410A for capacities.

Valves with ODF solder connections are supplied standard with 1/4" ODF external equalizer, 1/4" SAE Flare external equalizer available on special order. Pilot operated models are supplied with 1/4" SAE external equalizer.

## Capacities – kW

Capacities based on 3.3°C evaporator temperature change from closed to rated opening (does not apply to pilot operated models), discharge temperature 17°C above isentropic compression, 38°C condensing temperature, 0°C subcooling, 14°K superheat at the compressor and includes both the hot gas bypassed and liquid refrigerant for desuperheating, regardless of whether the liquid is fed through the system thermostatic expansion valve or auxiliary desuperheating thermostatic expansion valve.

REFRIGERANT	MINIMUM ALLOWABLE EVAPORATOR TEMP. °C	VALVE TYPE & ADJUSTMENT RANGE (bar)														
		ADRI-1-1/4		ADRS-2		ADRP-3		ADRHE-6		DRHE-6				SHGB-8	SHGB-15	
		ADRIE-1-1/4	ASRSE-2	ADRPPE-3	ADRHE-6	(Adjustable "Remote Bulb" Model)*				SHGBE-8	SHGBE-15					
	0/3.79	0/5.17	0/6.90	0/2.07	0/5.52	0/2.07	0/5.52	0/2.07	0/5.52	1.72/2.41	2.21/3.03	3.79/4.83	4.48/5.52	0/6.90	0/5.17	
22	5	—	2.04	1.86	—	12.3	—	21.1	—	32.2	—	—	69.7	—	55.3	204
	-5	1.55	2.25	1.90	—	12.5	—	22.0	—	34.8	—	—	59.5	—	56.0	218
	-15	2.22	2.11	1.72	13.7	12.9	26.0	23.2	48.9	38.3	—	—	—	—	57.0	232
	-25	2.08	1.76	1.55	13.2	12.8	26.2	23.4	49.6	38.7	—	—	—	—	57.0	243
134a	5	1.41	1.51	1.19	—	9.40	—	17.4	—	32.9	33.9	—	—	—	38.3	144
	-5	1.44	1.37	1.12	9.15	8.59	17.4	15.5	32.9	25.5	29.2	—	—	—	38.3	151
	-15	1.34	1.09	0.98	8.66	—	17.2	—	33.1	—	—	—	—	—	38.7	162
404A	5	—	—	1.94	—	—	—	—	—	—	—	—	—	—	61.6	—
	-5	—	2.36	2.11	—	13.7	—	23.6	—	36.6	—	—	—	75.3	62.3	225
	-15	2.35	2.50	1.97	—	14.1	—	25.2	—	41.2	—	—	—	—	63.0	229
	-25	2.39	2.15	1.79	14.7	14.1	28.4	25.6	53.8	42.6	—	—	—	—	63.0	229
407C	5	—	2.74	2.29	—	14.9	—	26.4	—	42.6	—	—	80.5	—	65.4	260
	-5	2.15	2.74	2.22	—	14.9	—	26.4	—	42.6	—	67.9	—	—	65.8	264
	-15	2.60	2.39	1.97	15.9	15.2	30.4	27.5	57.3	45.7	—	—	—	—	66.5	267
	-25	2.39	1.97	1.76	15.2	14.9	30.4	27.1	58.0	45.4	—	—	—	—	67.2	271
507	5	—	—	1.86	—	—	—	—	—	—	—	—	—	—	61.2	—
	-5	—	2.28	2.07	—	13.6	—	23.2	—	35.9	—	—	—	—	62.3	225
	-15	—	2.50	2.00	—	13.8	—	24.9	—	40.5	—	—	—	—	62.6	225
	-25	2.43	2.18	1.83	14.7	14.1	28.2	25.5	53.5	42.2	—	—	—	—	63.0	229

\*These models applicable on air conditioning systems only. For complete information consult your nearest Sporlan Wholesaler or email europecold@parker.com and request Bulletin 90-40.



# DISCHARGE BYPASS VALVES



**UL** and **CSA**  
LISTED or  
Recognized

Crankcase Pressure Regulating Valves are designed to prevent overloading of the compressor motor by limiting the crankcase pressure to a predetermined maximum value during and after a defrost cycle or a normal shutdown period. These valves automatically throttle the vapor flow from the evaporator until the compressor can handle the load.

Sporlan manufactures five adjustable direct acting models...CRO-4, CRO-6, CROT-6, CRO-10 and CROT-10...all models respond only to their outlet pressure and modulate to prevent the suction pressure at the compressor from rising above the valve setting. Since these valves are adjustable, the setting may be altered to suit the specific system requirements.

ing above the valve setting. Since these valves are adjustable, the setting may be altered to suit the specific system requirements.

## Selection and Capacity Ratings

The ratings for these valves vary depending on these items: design suction pressure after pulldown, maximum allowable suction pressure recommended by the compressor or unit manufacturer (this is the valve setting), and pressure drop across the valve. The difference between the design suction pressure and the valve setting determines how much of the valve stroke is used. Therefore, the valve setting should be kept as high as possible without exceeding the recommendation of the compressor or unit manufacturer. Once this information is available, the correct CRO can be selected from the data below.

Connections - (Standard Connections are in **BOLD** type).

**CRO-4** - 3/8", 1/2" ODF Solder and 3/8", 1/2" SAE Flare

**CRO-6**, \***CROT-6** - 5/8", 7/8", 1-1/8" ODF Solder and 1/2", 5/8" SAE Flare.

**CRO-10**, \***CROT-10** - 7/8", 1-1/8", 1-3/8" ODF Solder.

\*"T" indicates access valve on inlet connection.

## Installation

Crankcase pressure regulating valves are installed in the suction line between the evaporator and compressor, and downstream of any other controls or accessories. When installing CRO's with solder type connections, the internal parts should be protected by wrapping the valve with a wet cloth.

CRO-6 & CRO-10 are listed by Underwriters Laboratories, Inc. - Guide - SFJQ - File No. SA5460 and Canadian Standards Association - Certification Record No. LR-19953. CRO-4 is a recognized component UL Guide No. SFJQ8, File Number SA5460, also a recognized component in Canada.

## CRO - Valve Nomenclature/Ordering Instructions

CRO	T	10	0/60	1-1/8 ODF
Valve Type Close on Rise of Outlet Pressure	Access Valve on Inlet Connection CROT-6 or CROT-10	Port Size in Eighths of an Inch	Adjustment Range - psig  See specifications for available adjustment ranges	Connections - ODF Solder or SAE Flare

## Capacities - kW

Capacities based on 38°C condensing temperature, 6°K superheat, 0°C subcooling, and 0.14 bar pressure drop across valve.

TYPE and ADJUSTMENT RANGE	DESIGN EVAP. TEMP. °C	SATURATED SUCTION PRESSURE - bar (Reference)	R-22						DESIGN EVAP. TEMP. °C	SATURATED SUCTION PRESSURE - bar (Reference)	R-134a					
			VALVE SETTING - barg								VALVE SETTING - barg					
			0.7	1.4	2.1	2.8	3.5	4.2			0.7	1.4	2.1	2.8	3.5	4.2
<b>CRO-4</b> 0/20 psig 0/1.4 barg	-40	0.0	0.61	0.61	—	—	—	—	-25	0.0	0.59	0.59	—	—	—	—
	-35	0.3	0.61	0.70	—	—	—	—	-20	0.3	0.59	0.69	—	—	—	—
	-30	0.6	0.53	0.80	—	—	—	—	-15	0.6	0.52	0.79	—	—	—	—
	-25	1.0	—	—	—	—	—	—	-10	1.0	—	0.79	—	—	—	—
<b>CRO-4</b> 0/50 psig 0/3.4 barg	-40	0.0	0.48	0.61	0.61	0.61	—	—	-20	0.3	0.49	0.64	0.69	0.69	—	—
	-30	0.6	0.50	0.67	0.80	0.80	—	—	-15	0.6	0.49	0.66	0.79	0.79	—	—
	-25	1.0	—	0.66	0.85	0.91	—	—	-5	1.4	—	—	0.83	1.02	—	—
	-15	1.9	—	—	0.76	0.99	—	—	5	2.5	—	—	—	0.91	—	—
<b>CRO-4</b> 0/75 psig 0/5.2 barg	-40	0.0	0.46	0.48	0.61	0.61	0.61	0.61	-15	0.6	0.49	0.62	0.76	0.79	0.79	0.79
	-30	0.6	0.50	0.64	0.77	0.80	0.80	0.80	-10	1.0	—	0.64	0.78	0.90	0.90	0.90
	-15	1.9	—	—	0.75	0.93	1.12	1.14	-5	1.4	—	—	0.79	0.95	1.02	1.02
	-10	2.5	—	—	—	0.86	1.07	1.27	5	2.5	—	—	—	0.89	1.10	1.28
<b>CRO(T)-6</b> 0/60 psig 0/4.1 barg	-40	0.0	1.62	2.54	3.45	4.27	4.27	—	-15	0.6	1.21	2.35	3.50	4.65	5.49	—
	-30	0.6	—	2.41	3.57	4.73	5.58	—	-10	1.0	—	2.03	3.32	4.61	5.90	—
	-15	1.9	—	—	2.07	3.67	5.27	—	-5	1.4	—	—	2.90	4.34	5.79	—
	-5	3.2	—	—	—	—	2.99	—	5	2.5	—	—	—	—	4.55	—
<b>CRO(T)-10</b> 0/60 psig 0/4.1 barg	-40	0.0	5.29	9.79	9.79	9.79	9.79	—	-15	0.6	—	7.83	12.3	12.3	12.3	—
	-30	0.6	—	7.95	12.5	12.5	12.5	—	-10	1.0	—	4.63	12.7	13.9	13.9	—
	-15	1.9	—	—	2.16	12.1	17.3	—	-5	1.4	—	—	8.72	15.6	15.6	—
	-5	3.2	—	—	—	—	5.13	—	5	2.5	—	—	—	—	16.2	—
<b>CRO(T)-6</b> 30/110 psig 2.1/7.6 barg	-10	2.5	VALVE SETTING - barg						-10	1.0	VALVE SETTING - barg					
			2.7	3.4	4.1	4.8	5.5	6.2			2.7	3.4	4.1	4.8	5.5	6.2
<b>CRO(T)-10</b> 30/110 psig 2.1/7.6 barg	-5	3.2	—	2.53	3.84	5.15	6.46	7.76	-5	1.4	—	4.24	5.21	6.19	7.05	7.05
	0	4.0	—	—	2.68	4.11	5.55	6.98	0	1.9	—	—	5.10	6.18	7.27	7.91
	5	4.8	—	—	—	—	4.16	5.73	5	2.5	—	—	—	5.94	7.14	8.35
	-10	2.5	1.78	9.24	16.7	19.1	19.1	19.1	-10	1.0	13.2	13.9	13.9	13.9	13.9	13.9
<b>CRO(T)-10</b> 30/110 psig 2.1/7.6 barg	-5	3.2	—	2.31	10.5	18.7	21.1	21.1	-5	1.4	—	—	15.6	15.6	15.6	15.6
	0	4.0	—	—	1.75	10.7	19.7	23.1	0	1.9	—	—	17.4	17.4	17.4	17.4
	5	4.8	—	—	—	—	9.48	19.3	5	2.5	—	—	—	19.4	19.4	19.4

# CRANKCASE PRESSURE REGULATING VALVES

## Capacities – kW

Capacities based on 38°C condensing temperature, 6°K superheat, 0°C subcooling, and 0.14 bar pressure drop across valve.

TYPE and ADJUSTMENT RANGE	DESIGN EVAP. TEMP. °C	SATURATED SUCTION PRESSURE – bar (Reference)	R-404A						DESIGN EVAP. TEMP. °C	SATURATED SUCTION PRESSURE – bar (Reference)	R-407C						
			VALVE SETTING – barg								VALVE SETTING – barg						
			0.7	1.4	2.1	2.8	3.5	4.2			0.7	1.4	2.1	2.8	3.5	4.2	
CRO-4 0/20 psig 0/1.4 barg	-40	0.3	0.41	0.47	—	—	—	—	-40	-0.15	—	—	—	—	—	—	
	-35	0.6	0.35	0.55	—	—	—	—	-35	0.1	0.57	0.57	—	—	—	—	
	-30	1.0	—	0.55	—	—	—	—	-30	0.4	0.55	0.67	—	—	—	—	
	-25	1.5	—	—	—	—	—	—	-25	0.7	—	0.77	—	—	—	—	
CRO-4 0/50 psig 0/3.4 barg	-40	0.3	0.34	0.44	0.47	0.47	—	—	-35	0.1	0.45	0.57	0.57	0.57	—	—	
	-30	1.0	—	0.46	0.59	0.64	—	—	-30	0.4	0.47	0.61	0.67	0.67	—	—	
	-25	1.5	—	—	0.58	0.73	—	—	-25	0.7	—	0.63	0.77	0.77	—	—	
	-15	2.6	—	—	—	0.64	—	—	-15	1.6	—	—	0.77	0.98	—	—	
CRO-4 0/75 psig 0/5.2 barg	-40	0.3	0.33	0.41	0.47	0.47	0.47	0.47	-35	0.1	0.42	0.52	0.57	0.57	0.57	0.57	
	-30	1.0	—	0.45	0.55	0.64	0.64	0.64	-30	0.4	0.45	0.57	0.67	0.67	0.67	0.67	
	-15	2.6	—	—	—	0.63	0.78	0.93	-15	1.6	—	—	0.74	0.90	1.00	1.00	
	-10	3.3	—	—	—	—	0.71	0.88	-10	2.2	—	—	—	0.87	1.06	1.13	
CRO(T)-6 0/60 psig 0/4.1 barg	-40	0.3	1.00	1.70	2.39	3.09	3.29	—	-35	0.1	1.47	2.33	3.19	3.99	3.99	—	
	-30	1.0	—	1.40	2.31	3.23	4.14	—	-30	0.4	—	2.34	3.32	4.30	4.64	—	
	-20	2.0	—	—	—	2.57	3.75	—	-15	1.6	—	—	2.54	3.96	5.37	—	
	-10	3.3	—	—	—	—	—	—	-5	2.8	—	—	—	—	3.78	—	
CRO(T)-10 0/60 psig 0/4.1 barg	-40	0.3	2.33	6.67	7.47	7.47	7.47	—	-35	0.1	4.71	9.17	9.17	9.17	9.17	—	
	-30	1.0	—	2.97	8.67	9.86	9.86	—	-30	0.4	—	9.03	10.5	10.5	10.5	—	
	-20	2.0	—	—	—	8.23	12.7	—	-15	1.6	—	—	6.61	15.3	15.3	—	
	-10	3.3	—	—	—	—	—	—	-5	2.8	—	—	—	—	11.5	—	
			VALVE SETTING – barg									VALVE SETTING – barg					
			2.7	3.4	4.1	4.8	5.5	6.2				2.7	3.4	4.1	4.8	5.5	6.2
CRO(T)-6 30/110 psig 2.1/7.6 barg	-15	2.6	1.54	2.43	3.32	4.21	5.09	5.98	-10	2.2	2.57	4.58	6.16	7.74	7.78	7.78	
	-10	3.3	—	—	2.75	3.75	4.74	5.74	-5	2.8	—	3.01	4.19	5.38	6.57	7.75	
	-5	4.1	—	—	—	2.94	4.05	5.16	0	3.6	—	—	3.31	4.62	5.94	7.26	
	0	5.0	—	—	—	—	2.94	4.17	5	4.5	—	—	—	3.39	4.85	6.30	
CRO(T)-10 30/110 psig 2.1/7.6 barg	-15	2.6	—	6.21	11.8	14.3	14.3	14.3	-10	2.2	5.47	17.1	17.1	17.1	17.1	17.1	
	-10	3.3	—	—	6.98	13.2	16.0	16.0	-5	2.8	—	6.74	14.2	19.1	19.1	19.1	
	-5	4.1	—	—	—	6.85	13.8	17.9	0	3.6	—	—	7.04	15.3	21.2	21.2	
	0	5.0	—	—	—	—	5.41	13.1	5	4.5	—	—	—	5.91	15.1	23.5	

TYPE and ADJUSTMENT RANGE	DESIGN EVAP. TEMP. °C	SATURATED SUCTION PRESSURE – bar (Reference)	R-409A						DESIGN EVAP. TEMP. °C	SATURATED SUCTION PRESSURE – bar (Reference)	R-507						
			VALVE SETTING – barg								VALVE SETTING – barg						
			0.7	1.4	2.1	2.8	3.5	4.2			0.7	1.4	2.1	2.8	3.5	4.2	
CRO-4 0/20 psig 0/1.4 barg	-25	0.0	0.60	0.60	—	—	—	—	-40	0.4	0.39	0.47	—	—	—	—	
	-20	0.3	0.61	0.70	—	—	—	—	-35	0.7	—	0.55	—	—	—	—	
	-15	0.6	0.54	0.80	—	—	—	—	-30	1.1	—	0.50	—	—	—	—	
	-10	1.0	—	0.82	—	—	—	—	-25	1.6	—	—	—	—	—	—	
CRO-4 0/50 psig 0/3.4 barg	-20	0.3	0.50	0.65	0.70	0.70	—	—	-40	0.4	0.33	0.43	0.47	0.47	—	—	
	-15	0.6	0.51	0.68	0.80	0.80	—	—	-30	1.1	—	0.44	0.57	0.64	—	—	
	-5	1.4	—	—	0.85	1.02	—	—	-25	1.6	—	—	0.55	0.70	—	—	
	5	2.4	—	—	—	0.94	—	—	-15	2.8	—	—	—	—	—	—	
CRO-4 0/75 psig 0/5.2 barg	-15	0.6	0.50	0.63	0.77	0.80	0.80	0.80	-40	0.4	0.32	0.40	0.47	0.47	0.47	0.47	
	-10	1.0	—	0.65	0.80	0.90	0.90	0.90	-30	1.1	—	0.43	0.53	0.64	0.64	0.64	
	-5	1.4	—	—	0.80	0.97	1.02	1.02	-15	2.8	—	—	—	—	0.73	0.89	
	5	2.4	—	—	—	0.91	1.11	1.27	-10	3.5	—	—	—	—	0.65	0.82	
CRO(T)-6 0/60 psig 0/4.1 barg	-15	0.6	1.27	2.43	3.58	4.74	5.54	—	-40	0.4	0.94	1.64	2.33	3.02	3.28	—	
	-10	1.0	—	2.12	3.42	4.71	6.00	—	-30	1.1	—	1.27	2.18	3.08	3.99	—	
	-5	1.4	—	—	3.01	4.45	5.89	—	-20	2.1	—	—	—	2.32	3.48	—	
	5	2.4	—	—	—	—	4.74	—	-10	3.5	—	—	—	—	—	—	
CRO(T)-10 0/60 psig 0/4.1 barg	-15	0.6	1.02	8.23	12.4	12.4	12.4	—	-40	0.4	1.94	6.25	7.43	7.43	7.43	—	
	-10	1.0	—	5.16	13.2	13.9	13.9	—	-30	1.1	—	2.16	7.81	9.78	9.78	—	
	-5	1.4	—	—	9.47	15.6	15.6	—	-20	2.1	—	—	—	6.66	12.6	—	
	5	2.4	—	—	—	—	17.6	—	-10	3.5	—	—	—	—	—	—	
			VALVE SETTING – barg									VALVE SETTING – barg					
			2.7	3.4	4.1	4.8	5.5	6.2				2.7	3.4	4.1	4.8	5.5	6.2
CRO(T)-6 30/110 psig 2.1/7.6 barg	-10	1.0	3.47	4.33	5.20	6.07	6.26	6.26	-15	2.8	—	2.20	3.08	3.95	4.83	5.71	
	-5	1.4	—	4.31	5.28	6.25	7.03	7.03	-10	3.5	—	—	2.45	3.43	4.41	5.39	
	0	1.9	—	—	5.18	6.25	7.33	7.84	-5	4.3	—	—	—	2.56	3.65	4.74	
	5	2.4	—	—	—	6.03	7.22	8.41	0	5.2	—	—	—	—	2.46	3.67	
CRO(T)-10 30/110 psig 2.1/7.6 barg	-10	1.0	13.6	13.9	13.9	13.9	13.9	13.9	-15	2.8	—	4.81	10.3	14.1	14.1	14.1	
	-5	1.4	—	15.6	15.6	15.6	15.6	15.6	-10	3.5	—	—	5.17	11.3	15.8	15.8	
	0	1.9	—	—	17.3	17.3	17.3	17.3	-5	4.3	—	—	—	4.56	11.4	17.6	
	5	2.4	—	—	—	19.1	19.1	19.1	0	5.2	—	—	—	—	2.57	10.2	



# DISCHARGE BYPASS VALVES

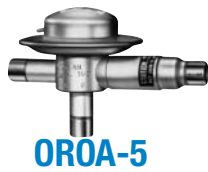

Listed by Underwriters' Laboratories, Inc. Guide SFJQ2 File No. SA5460



## High and Low Ambient Stability

The design of air conditioning systems utilizing air cooled condensing units involves two main problems that must be solved if the system is to operate reliably and economically... **high ambient** and **low ambient** operation. If the condensing unit is properly sized, it will operate satisfactorily during extremely high ambient temperatures. However, some units will be required to operate at ambient temperatures below their design dry bulb temperature during most of the year, the solution to low ambient operation is more complex.

Without good head pressure control during low ambient operation, the system can experience both running cycle and off-cycle problems. Since the pressure differential across the thermostatic expansion valve port affects the rate of refrigerant flow, low head pressure generally causes insufficient refrigerant to be fed to the evaporator. Failure to have sufficient head pressure will result in low suction pressure and/or iced evaporator coils.

The primary off-cycle problem is refrigerant migration to the condenser. Insufficient flow through the TEV will cause a low suction pressure.

The typical method of maintaining normal head pressure in a refrigeration system during periods of low ambient temperature is to restrict liquid flow from the condenser to the receiver, and at the same time divert hot gas to the inlet of the receiver. This backs liquid refrigerant up into the condenser reducing its capacity which in turn increases the condensing pressure. At the same time the hot gas raises liquid pressure in the receiver, allowing the system to operate normally.

Sporlan Head Pressure Control for systems with air cooled condensers can be accomplished using one of several valve options; the non-adjustable OROA-5, the adjustable ORI/ORD combination, or the economical LAC series.

## Specifications and Dimensions

VALVE TYPE	STANDARD FACTORY SETTING bar	CONNECTIONS ODF SOLDER (Inches)		DIMENSIONS – mm								WEIGHT kg		REPLACEMENT PARTS		
		INLET(S)	OUTLET	A	B	C	D	E	F	G	I	NET	SHIP			
ORI-6-65/225-H	8.3	5/8	5/8	250	128	162	—	—	—	—	—	—	.45	.57	Inlet Strainer	825-5
		7/8	7/8													825-7
		1-1/8	1-1/8													825-9
ORI-10-65/225-H	8.3	1-1/8	1-1/8	280	139	167	—	—	—	—	—	1.13	1.25	825-9		
		1-3/8	1-3/8											825-11		
ORD-4-20	1.4	5/8	5/8	167	25	—	—	—	—	—	—	.15	.23	825-5		
OROA-5	6.9, 12.4 or 14.5	1 5/8	5/8	151	95	48	55	—	—	—	—	.91	1.02	825-5		
		2 5/8	7/8	157	102	54	61							825-7		
		1 5/8	7/8	157	102	54	61							825-7		

1 Discharge Connection 2 Condenser Connection

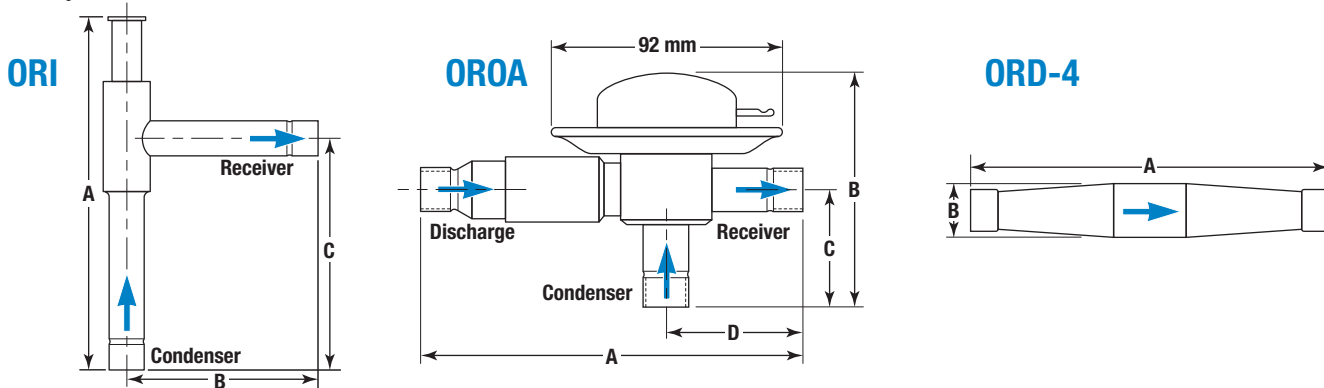

## ORI – Valve Nomenclature/Ordering Instructions

<b>ORI</b>	<b>6</b>	<b>65/225</b>	<b>7/8" ODF</b>	<b>With Strainer</b>	<b>H</b>
Valve Type: Open on Rise of Inlet Pressure	Port Size Eighth of an Inch	Nominal Adjustment Range (psig)	Connections - Solder	Inlet Strainer (Optional)	Designates High Pressure Bellows

## OROA – Valve Nomenclature/Ordering Instructions

<b>OROA</b>	<b>5</b>	<b>180</b>	<b>5/8" ODF</b>	<b>With Strainer</b>
Valve Type: Open on Rise of Outlet Pressure	Port Size Eighth of an Inch	Pressure Setting (psig)	Connections - Solder	Inlet Strainer (Optional)

## ORD-4

<b>ORD</b>	<b>4</b>	<b>20</b>
Valve Type: Open on Rise of Differential Pressure	Port Size Eighth of an Inch	Opening Pressure Differential (psi)

# CRANKCASE PRESSURE REGULATING VALVES

## Specifications and Dimensions

VALVE TYPE	STANDARD FACTORY SETTING bar	CONNECTIONS ODF SOLDER (Inches)		DIMENSIONS – mm								WEIGHT kg		REPLACEMENT PARTS			
		INLET(S)	OUTLET	A	B	C	D	E		F	G	I	NET		SHIP		
LAC-4	6.9, 12.4 or 14.5	1/4	1/4	45	48	77	61	120					.34	.39	Replacement Elements	Not Available	
		3/8	3/8										.36	.40			
		1/2	1/2										.37	.41			
LAC-4-DS		3/8	3/8	45	48	77	61	155					.40	.46			Non-Adjustable Dome Element: D3L (specify setting) or Non-Adjustable Remote Bulb Element: R3L (specify setting)
		1/2	1/2										.43	.49			
LAC-5		1/2	1/2	42	41	96	76	D3L	155	142	—	—	—	1.13			1.20
		5/8	5/8	44	43	98	78		157	144				1.16		1.22	
		7/8	7/8	57	55	110	91		170	157				1.18		1.25	
		1-1/8	1-1/8	61	60	114	95		173	161				1.25		1.32	
LAC-10		1 1-3/8	7/8	72	68	112	88	R3L	176	163				1.45		1.55	
	2 7/8	1-1/8	65		123	98	187		174	1.49				1.59			
	2 1-1/8																

1 Discharge Connection  
2 Condenser Connection

### LAC-4

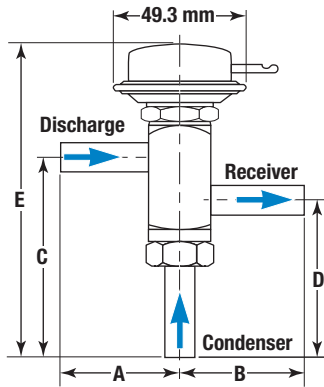

### LAC-4-DS

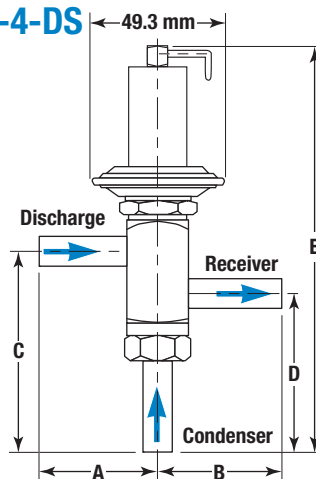

### LAC-5 & 10

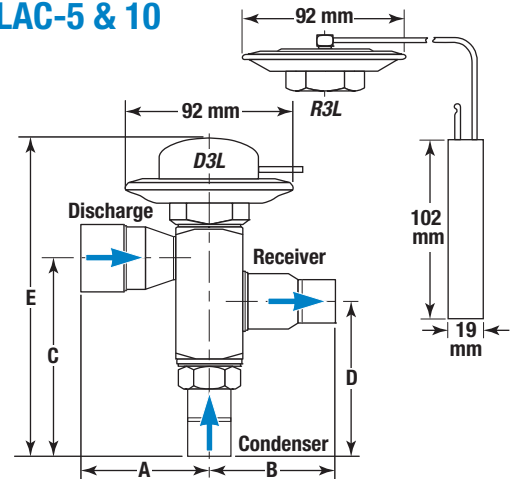

## LAC – Valve Nomenclature/Ordering Instructions

To eliminate shipment delays, specify complete valve designations.

<b>LAC</b>	<b>4</b>	<b>DS</b>	<b>100/180</b>	<b>3/8"</b>	<b>X</b>	<b>3/8"</b>	<b>X</b>	<b>3/8</b>	<b>ODF</b>
Valve Type: Low Ambient Control	Valve Size	Dual Setting Omit for standard dome element	Valve Setting(s) (psig) Specify one setting for standard dome element	Discharge Connection (Inches)		Condenser Connection (Inches)		Receiver Connection (Inches)	Solder Connections
<b>LAC</b>	<b>5</b>	<b>180</b>	<b>R</b>	<b>5/8"</b>	<b>X</b>	<b>5/8"</b>	<b>X</b>	<b>3/8</b>	<b>ODF</b>
Valve Type: Low Ambient Control	Valve Size	Valve Setting(s) (psig)	Indicates Remote Bulb Model Delete for standard dome element	Discharge Connection (Inches)		Condenser Connection (Inches)		Receiver Connection (Inches)	Solder Connections

# DISCHARGE BYPASS VALVES

## Low Ambient (WINTER) Capacities – kW of Refrigeration

Capacities are based on -20°C evaporator temperature, 35°C condenser, 6°C subcooled liquid.

REFRIGERANT Valve Setting (bar)	MINIMUM AMBIENT DESIGN TEMP. °C	PRES- SURE DROP ACROSS VALVE (bar)	VALVE TYPE					REFRIGERANT Valve Setting (bar)	MINIMUM AMBIENT DESIGN TEMP. °C	PRES- SURE DROP ACROSS VALVE (bar)	VALVE TYPE				
			LAC-4	LAC-5	LAC-10	OROA-5	ORD-4				LAC-4	LAC-5	LAC-10	OROA-5	ORD-4
<b>22 407C</b> (12.4 bar)	-30	0.07	5.96	10.6	25.4	—	—	<b>404A</b> (14.5 bar)	-30	0.07	4.37	7.75	18.7	—	—
		0.14	8.38	14.9	35.7	—	—			0.14	6.15	11.0	26.2	—	—
		0.35	13.1	23.6	55.5	—	—			0.35	9.63	17.3	40.9	—	—
		1.60	26.9	49.6	112	54.4	54.4			1.60	19.9	36.5	83.0	39.5	39.5
	-20	2.00	29.8	55.2	123	83.3	83.3		2.00	22.0	40.6	91.5	60.4	60.4	
		0.07	6.38	11.3	27.1	—	—		0.07	4.64	8.20	19.7	—	—	
		0.14	8.97	16.0	38.0	—	—		0.14	9.52	11.6	27.7	—	—	
		0.35	14.0	25.2	59.1	—	—		0.35	10.2	18.3	43.1	—	—	
	-10	1.60	28.8	53.0	119	61.3	61.3		1.60	21.1	38.6	87.4	44.0	44.0	
		2.00	31.8	59.0	131	93.8	93.8		2.00	23.3	43.0	96.3	67.4	67.4	
		0.07	6.91	12.2	29.2	—	—		0.07	4.98	8.78	21.1	—	—	
		0.14	9.71	17.2	40.8	—	—		0.14	7.00	12.4	29.5	—	—	
-30	0.35	15.2	27.2	63.5	—	—	0.35	10.9	19.6	45.9	—	—			
	1.60	31.1	57.2	127	71.2	71.2	1.60	22.5	41.3	92.9	50.7	50.7			
	2.00	34.3	63.7	140	109	109	2.00	24.9	46.0	102	77.6	77.6			
	0.07	4.86	8.65	20.9	—	—	0.07	4.12	7.32	17.6	—	—			
<b>134a</b> (6.9 bar)	-30	0.14	6.83	12.2	29.2	—	—	<b>507</b> (14.5 bar)	-30	0.14	5.80	10.3	24.8	—	—
		0.35	10.7	19.2	45.4	—	—			0.35	9.10	16.3	38.6	—	—
		1.60	21.4	40.1	88.8	40.6	40.6			1.60	18.8	34.5	78.5	37.2	37.2
		2.00	23.5	44.5	96.6	62.4	62.4			2.00	20.8	38.4	86.5	57.0	57.0
	-20	0.07	5.24	9.3	22.4	—	—		0.07	4.40	7.79	18.7	—	—	
		0.14	7.36	13.1	31.3	—	—		0.14	6.20	11.0	26.3	—	—	
		0.35	11.5	20.7	48.5	—	—		0.35	9.70	17.4	40.9	—	—	
		1.60	23.1	43.1	94.9	45.7	45.7		1.60	20.0	36.7	83.0	41.9	41.9	
	-10	2.00	25.3	47.8	103	70.2	70.2		2.00	22.1	40.9	91.5	64.1	64.1	
		0.07	5.73	10.1	24.3	—	—		0.07	4.75	8.38	20.1	—	—	
		0.14	8.05	14.3	34.0	—	—		0.14	6.68	11.8	28.1	—	—	
		0.35	12.5	22.6	52.7	—	—		0.35	10.4	18.7	43.8	—	—	
-30	1.60	25.2	47.1	103	53.3	53.3	1.60	21.5	39.5	88.6	48.7	48.7			
	2.00	27.6	52.2	112	81.8	81.8	2.00	23.8	43.9	97.6	74.6	74.6			
	0.07	6.06	10.8	20.3	—	—	—	—	—	—	—	—			
	0.14	8.54	15.2	28.5	—	—	—	—	—	—	—	—			
<b>R-410A</b> (20.3 bar)	-30	0.35	13.4	24.0	44.4	—	—	—	—	—	—	—	—		
		0.70	18.8	33.9	61.8	—	—	—	—	—	—	—	—		
		0.07	6.48	11.5	21.6	—	—	—	—	—	—	—	—		
		0.14	9.13	16.2	30.3	—	—	—	—	—	—	—	—		
	-20	0.35	14.3	25.6	47.2	—	—	—	—	—	—	—	—		
		0.70	20.0	36.1	65.6	—	—	—	—	—	—	—	—		
		0.07	7.0	12.4	23.2	—	—	—	—	—	—	—	—		
		0.14	9.85	17.5	32.5	—	—	—	—	—	—	—	—		
	-10	0.35	15.4	27.6	50.6	—	—	—	—	—	—	—	—		
		0.70	21.6	38.9	70.4	—	—	—	—	—	—	—	—		
		—	—	—	—	—	—	—	—	—	—	—	—		
		—	—	—	—	—	—	—	—	—	—	—	—		

## High Ambient (SUMMER) Capacities – kW of Refrigeration

Capacities are based on -20°C evaporator temperature, 43°C condenser, 6°C subcooled liquid.

REFRIGERANT	PRESSURE DROP ACROSS VALVE (bar)	VALVE TYPE							REFRIGERANT	PRESSURE DROP ACROSS VALVE (bar)	VALVE TYPE						
		LAC-4	LAC-5	LAC-10	OROA-5	ORI-6	ORI-10	ORD-4			LAC-4	LAC-5	LAC-10	OROA-5	ORI-6	ORI-10	ORD-4
<b>22 407C</b>	0.07	9.13	19.5	41.5	37.0	26.0	69.2	—	<b>404A</b>	0.07	5.71	12.2	26.0	23.0	17.5	48.4	—
	0.14	12.8	27.6	57.7	52.1	37.8	95.6	—		0.14	7.98	17.2	36.1	32.5	25.4	66.8	—
	0.21	15.5	33.9	69.9	63.7	47.0	116	—		0.21	9.70	21.1	43.8	39.7	31.7	80.7	—
	0.28	17.8	39.1	80.1	73.5	54.9	132	—		0.28	11.2	24.4	50.2	45.8	37.0	92.3	—
	0.35	19.9	43.7	89.0	82.1	61.9	147	—		0.35	12.4	27.2	55.8	51.2	41.7	102	—
<b>134a</b>	0.07	8.15	17.4	37.1	33.0	18.2	45.6	—	<b>507</b>	0.07	5.58	11.9	25.5	22.6	17.8	49.3	—
	0.14	11.4	27.4	51.5	46.5	26.4	63.0	—		0.14	7.80	16.9	35.3	31.8	25.8	68.1	—
	0.21	13.9	30.2	62.4	56.9	32.9	76.1	—		0.21	9.49	20.7	42.8	38.9	32.1	82.3	—
	0.28	15.9	34.9	71.5	65.6	38.5	87.0	—		0.28	10.9	23.9	49.1	44.9	37.5	94.1	—
<b>410A</b>	0.35	17.7	39.0	79.5	73.2	43.4	96.5	—	0.35	12.2	26.7	54.5	50.1	42.4	104	—	
	0.07	8.70	18.6	29.3	—	—	—	—	—	—	—	—	—	—	—	—	
	0.14	12.2	26.3	40.7	—	—	—	—	—	—	—	—	—	—	—	—	
	0.21	14.8	32.2	49.3	—	—	—	—	—	—	—	—	—	—	—	—	
	0.28	17.0	37.2	56.5	—	—	—	—	—	—	—	—	—	—	—	—	
0.35	18.9	41.6	62.8	—	—	—	—	—	—	—	—	—	—	—	—		

# CRANKCASE PRESSURE REGULATING VALVES

In many supermarket applications refrigerant gas from the discharge line or from the top of the receiver is used for defrost. This method of defrost diverts a portion of the hot gas or cool gas (from the top of the receiver) to the suction line and back through the evaporator being defrosted. The gas condenses in the evaporator and flows in reverse, through check valves, around the TEV and liquid line solenoid valve. Liquid refrigerant then flows to the liquid header where it is distributed to evaporators not in the defrost cycle. In order for this reverse flow to occur, the pressure of the defrost header must be greater than the pressure of the liquid header. The difference in pressure is known as the defrost differential.

Several methods are used to obtain the defrost differential. The (O)LDR is designed to maintain a differential pressure between the receiver and the liquid header.

Sporlan liquid line differential valves have a solenoid bypass feature that allows the valve to remain full open or modulate to maintain a differential. We supply two versions of liquid line differential valves:



**DDR-20**



**OLDR-15**

The **OLDR** is in the **full open position** when the coil is de-energized, and it's in differential operation mode when the coil is energized.

The **LDR** is in **differential operation mode** when the coil is de-energized, and it is in the full open position when the coil is energized.

The **DDR-20** is designed to create a differential pressure between its inlet (discharge) pressure and the receiver pressure.

A solenoid bypass feature is incorporated in the valve so that the valve can be made to go full open when there is no need for a differential to be created. Energizing the solenoid coil opens the valve fully.

## Location and Piping

The (O)LDR valves is located between the receiver and the liquid header. The DDR-20 is located in the discharge line before the condenser. The two types of defrost differential valves (liquid line and discharge line) are not to be applied on the same system.

## Adjustment Range and Pressure Settings

All defrost differential valves are set by turning the adjusting stem located under the cap on the pilot differential valve. The adjustment range is 0.3 to 3.5 bar. The (O)LDR has a factory setting of 1.2 bar and the DDR-20 has a factory setting of 2 bar. Turning the stem clockwise increases the setting, counter-clockwise decreases the setting.

## Capacities – kW

Capacities based on 5°C evaporator temperature, 38°C condensing temperature, 14°K superheat return gas, discharge gas temperature 28°C above isentropic compression.

VALVE TYPE	REFRIGERANT								
	134a			404A & 507			407C		
	PRESSURE DROP ACROSS VALVE – bar								
	0.14	0.21	0.35	0.14	0.21	0.35	0.14	0.21	0.35
<b>LDR-15, OLDR-15</b>	155	190	246	110	135	174	153	187	242
<b>LDR-20, OLDR-20</b>	343	420	543	243	298	384	338	414	534
<b>DDR-20</b>	27	33	42	29	35	45	34	41	53

## OLDR – Valve Nomenclature/Ordering Instructions

<b>0</b>	<b>LDR</b>	<b>15</b>	<b>5/50</b>	<b>1-3/8" ODF</b>	<b>120/50-60</b>
Normally Open	Liquid Differential Regulator	Valve Size	Adjustment Range – psi	Connection (Inches)	Electrical Specifications

## DDR – Valve Nomenclature/Ordering Instructions

<b>DDR</b>	<b>20</b>	<b>5/50</b>	<b>1-5/8" ODF</b>	<b>120/50-60</b>
Discharge Differential Regulator	Valve Size	Adjustment Range – psi	Connection (Inches)	Electrical Specifications

## Specifications

VALVE TYPE	PORT SIZE – mm	DIFFERENTIAL SETPOINT RANGE	CONNECTIONS – Inches INLET x OUTLET	COIL
<b>OLDR-15</b>	25.4	0.34/3.4 bar	1-3/8 ODF x 1-3/8 ODF	MKC-2
<b>LDR-15</b>				OMKC-2
<b>OLDR-20</b>	33.3		1-5/8 ODF x 1-5/8 ODF or 2-1/8 ODF x 2-1/8 ODF	MKC-2
<b>LDR-20</b>				OMKC-2
<b>DDR-20</b>	33.3		1-5/8 ODF x 1-5/8 ODF	MKC-2

M.R.P. of 27.5 bar. MOPD of 20.5 bar.

For complete information consult your nearest Sporlan Wholesaler or email [europocold@parker.com](mailto:europocold@parker.com) and request Bulletin 90-50.

# DISCHARGE BYPASS VALVES

The Sporlan line of evaporator pressure regulating (EPR) valves are designed to provide an accurate and economical means of balancing system capacity and load requirements during “low” loads and/or while maintaining different evaporator conditions on multi-temperature evaporator systems. These valves control evaporator temperature by maintaining evaporator pressure. As the evaporator load increases the **ORI** valves will **Open on Rise of Inlet** pressure above the valve’s setting to provide more flow capacity to meet the evaporator load. When the evaporator load decreases the valves will modulate closed to maintain the pressure setting of the valve.

Sporlan offers a number of EPR valve types in various sizes, and with optional features to accommodate almost any industry requirement. For more complete information on any of the EPR valve types see your nearest Sporlan Wholesaler or email [europocold@parker.com](mailto:europocold@parker.com)

## Applications

- **Maintain minimum evaporator temperature to avoid frost on air coils and provide improved humidity control**
- **Evaporator temperature control for food merchandisers (single and multiple evaporator systems)**
- **Evaporator temperature control on water chilling units**

## Required Sizing Information

- **Refrigerant type**
- **Evaporator design capacity**
- **Design evaporator temperature or minimum evaporator pressure**
- **Available pressure drop**
- **Allowable evaporator pressure change (only applies to direct acting models)**

## Capacities – kW

Capacities based on 38°C condensing temperature, 0°C subcooling, 6°K superheat, 0.55 bar evaporator pressure change for 0/3.45 bar adjustment range, and a 0.83 bar evaporator pressure change for 2.07/6.90 bar adjustment range.

VALVE TYPE	EVAPORATOR TEMPERATURE °C	SATURATED PRESSURE – bar (Reference)					REFRIGERANT														
		REFRIGERANT					22		134a			404A			407C			507			
		22	134a	404A	407C	507	0.1	0.4	0.7	0.1	0.4	0.7	0.1	0.4	0.7	0.1	0.4	0.7	0.1	0.4	0.7
ORIT-6	5	4.83	2.48	6.03	4.35	6.32	3.85	7.16	8.75	2.89	5.01	5.60	3.36	6.30	7.78	3.57	6.54	7.87	3.31	6.22	7.70
	-5	3.21	1.42	4.12	2.77	4.34	3.19	5.73	6.73	2.29	3.67	3.77	2.71	4.94	5.90	2.87	5.04	5.75	2.68	4.90	5.90
	-15	1.95	0.63	2.62	1.57	2.79	2.58	4.39	4.79	1.76	2.45	2.45	2.14	3.72	4.19	2.24	3.67	3.82	2.12	3.74	4.28
	-25	1.00	0.05	1.49	0.70	1.61	2.04	3.16	3.19	1.29	1.53	1.53	1.65	2.66	2.74	1.71	2.44	2.44	1.64	2.68	2.80
ORIT-10	5	4.83	2.48	6.03	4.35	6.32	9.45	18.7	24.4	7.25	14.2	18.3	8.23	16.3	21.3	8.79	17.3	22.6	8.08	16.0	21.0
	-5	3.21	1.42	4.12	2.77	4.34	7.88	15.5	20.2	5.83	11.3	14.4	6.69	13.2	17.2	7.13	14.0	18.1	6.59	13.0	16.9
	-15	1.95	0.63	2.62	1.57	2.79	6.48	12.6	16.3	4.60	8.77	11.0	5.35	10.5	13.6	5.70	11.1	14.2	5.28	10.4	13.4
	-25	1.00	0.05	1.49	0.70	1.61	5.23	10.1	12.8	3.55	6.58	8.01	4.19	8.12	10.4	4.46	8.52	10.7	4.15	8.07	10.4

## ORIT-6 and -10 Features

- **Direct acting (most economical)**
- **Adjustable**
- **Hermetic construction (no gaskets or seals)**
- **Corrosion resistant construction**
- **Inlet pressure tap (standard)**
- **Inlet strainer (standard on ODF models)**

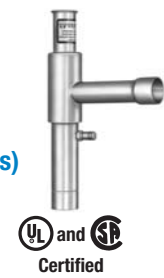

These direct acting EPRs are offered in two sizes. The direct acting design although economical requires an evaporator pressure change above the minimum evaporator pressure setting to provide the rated flow capacity. The nominal ratings are based on an 0.55 bar evaporator pressure change for the 0/3.45 bar adjustment range, and a 0.83 bar change for the 2.07/6.90 bar adjustment range. Valves should be selected for the desired maximum variation in evaporator pressure using the capacity multipliers below.

ALLOWABLE EVAPORATOR PRESSURE CHANGE – bar		0.14	0.28	0.41	0.55	0.69	0.83	0.97
<b>CAPACITY</b>	ORIT-6, 10-0/50	.3	.6	.8	1.0	1.2	1.3	1.4
<b>MULTIPLIER</b>	ORIT-6, 10-30/100	—	.2	.6	.7	.9	1.0	1.1

## Specifications

VALVE TYPE	PORT SIZE mm	ADJUSTMENT RANGE	STANDARD CONNECTIONS In BOLD
<b>ORIT-6</b>	19	<b>0/3.45</b> or 2.07/6.90 bar	1/2 & 5/8 SAE Flare* 1/2, 5/8, <b>7/8</b> & 1-1/8 ODF Solder
<b>ORIT-10</b>	31		<b>7/8, 1-1/8 &amp; 1-3/8</b> ODF Solder

Standard features in bold.  
\*Not available with inlet strainer.

## ORIT – Valve Nomenclature/Ordering Instructions

<b>ORI</b>	<b>T</b>	<b>6</b>	<b>0/50</b>	<b>7/8" ODF</b>
Valve Type: <b>Open on Rise of Inlet Pressure</b>	Pressure Tap on Inlet Connection	Port Size in Eighths of an Inch	Adjustment Range – psig*	Connection ODF Solder or SAE Flare

\* Other pressure ranges are available.



# CRANKCASE PRESSURE REGULATING VALVES

## (S)ORIT-12, -15 and -20 Features

- High side pilot for improved temperature control and low ΔP operation
- Adjustable
- Optional solenoid “stop” feature to close valve during defrost
- Normally open design allows system evacuation without manual operator

These EPRs are pilot operated using “high side” pressure and require a pilot supply connection from the compressor discharge to operate. They are designed to be “normally open” providing an unparalleled ability to operate with virtually no suction line pressure drop. The pilot operated design does not require the “allowable evaporator pressure change” necessary with the direct acting models, and can be simply sized based on design evaporator temperature and available pressure drop across the valve at full load conditions.

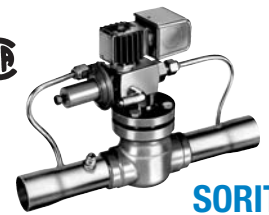

**S)ORIT**

## Specifications

VALVE TYPE	PORT SIZE mm	ADJUSTMENT RANGE bar	STANDARD COIL RATINGS *MKC-1		CONNECTIONS ODF SOLDER Inches
			VOLTS/CYCLES	WATTS	
(S)ORIT-12	19.8	0/6.90	24/50-60	10	1-1/8
(S)ORIT-15	25.4		120/50-60		1-3/8
(S)ORIT-20	33.3		208-240/50-60 120-208-240/50-60		1-5/8

\*Available with junction box or conduit boss at no extra charge.  
For voltage other than listed consult Bulletin 30-10.

## Capacities – kW

Capacities based on 15°C condensing temperature, 0°K superheat at the evaporator, and 14°K superheat at the valve.

VALVE TYPE	EVAPORATOR TEMPERATURE °C	REFRIGERANT															
		22				134a				404A				507			
		PRESSURE DROP ACROSS VALVE – bar															
		0.03	0.10	0.40	0.70	0.03	0.10	0.40	0.70	0.03	0.10	0.40	0.70	0.03	0.10	0.40	0.70
(S)ORIT-12	5	7.64	13.9	27.3	35.5	6.09	11.0	21.4	27.4	7.41	13.5	26.6	34.6	7.17	13.0	25.7	33.5
	-5	6.40	11.6	22.7	29.3	4.95	8.94	17.1	21.5	6.11	11.1	21.7	28.1	5.92	10.8	21.1	27.3
	-15	5.29	9.59	18.5	23.6	3.95	7.11	13.3	16.3	4.96	8.99	17.4	22.4	4.82	8.74	17.0	21.8
	-25	4.30	7.76	14.7	18.5	—	—	—	—	3.96	7.16	13.7	17.3	3.86	6.97	13.4	16.9
(S)ORIT-15	5	12.6	22.9	44.8	57.9	10.1	18.2	34.9	44.0	12.3	22.3	43.7	56.5	11.9	21.6	42.3	54.8
	-5	10.6	19.2	37.1	47.4	8.18	14.7	27.6	34.1	10.1	18.3	35.6	45.7	9.79	17.8	34.6	44.4
	-15	8.75	15.8	30.1	37.8	6.53	11.7	21.1	25.0	8.20	14.8	28.4	36.0	7.97	14.4	27.7	35.2
	-25	7.11	12.8	23.7	29.0	—	—	—	—	6.55	11.8	22.1	27.4	6.38	11.5	21.6	26.9
(S)ORIT-20	5	27.7	50.3	98.5	127	22.1	40.0	76.8	97.4	26.9	48.9	95.9	124	26.0	47.3	92.8	121
	-5	23.2	42.1	81.6	105	17.9	32.3	60.9	75.7	22.1	40.2	78.2	101	21.5	39.0	76.0	97.9
	-15	19.2	34.7	66.3	83.7	14.3	25.6	46.8	56.1	18.0	32.5	62.6	79.5	17.5	31.6	61.0	77.7
	-25	15.6	28.0	52.4	64.5	—	—	—	—	14.4	25.9	48.8	60.8	14.0	25.2	47.8	59.6

## Refrigerant Liquid Temperature Correction Factors

REFRIGERANT	LIQUID TEMPERATURE ENTERING VALVE °C										
	-15°	-10°	-5°	0°	5°	10°	15°	20°	30°	35°	40°
	CORRECTION FACTOR, CF LIQUID TEMPERATURE										
R-22	1.21	1.17	1.14	1.11	1.07	1.04	1.00	0.96	0.91	0.87	0.84
R-134a	1.25	1.21	1.17	1.14	1.09	1.05	1.00	0.95	0.89	0.84	0.81
R-404A	1.31	1.27	1.22	1.16	1.12	1.06	1.00	0.94	0.86	0.79	0.74
R-507	1.32	1.28	1.22	1.16	1.12	1.06	1.00	0.94	0.86	0.80	0.75

\*ARI standard capacities are based on 38°C saturated liquid temperature. Use the correction factor for 40°C liquid temperature and the capacities at 5°C evaporator temperature to determine approximate ARI standard capacity ratings.

Example: The capacity of a (S)ORIT-12 using R-404A, evaporator temperature of -5°C, 0.1 bar pressure drop across the valve and a liquid temperature of 10°C, is equal to 11.1 x 1.06 = 11.8 kW.

## Installation

When installing these valves with solder connections, the internal parts should be protected from overheating by wrapping the valve with a wet cloth.

## (S)ORIT – Valve Nomenclature/Ordering Instructions

<b>S</b>	<b>ORI</b>	<b>T</b>	<b>15</b>	<b>0/100</b>	<b>1-3/8" ODF</b>	<b>120/50-60</b>
Solenoid Stop Feature (optional)	Valve Type: Open on Rise of Inlet Pressure	Pressure Tap on Inlet Connection	Valve Size	Adjustment Range – psig*	Connections ODF Solder	Electrical Specifications for Solenoid Stop Feature (optional)

\* Other pressure ranges are available.

# DISCHARGE BYPASS VALVES

## (S)ORIT-PI-2, -3, -4 and -5 Features

- Piloted internally (No high side connection required)
- Superior corrosion resistance
- Optional solenoid “stop” feature to close valve during defrost
- Optional electric open feature for “two temperature operation”
- Manual lift stem (standard) to allow system evacuation

These EPRs are Piloted Internally using the natural pressure drop across the valve to operate and do not require a “high side” pilot connection. Like the (S)ORIT valves, the pilot operated design does not require the “allowable evaporator pressure change” necessary with the direct acting models, and can be simply sized based on design evaporator temperature and available pressure drop across the valve at full load conditions.

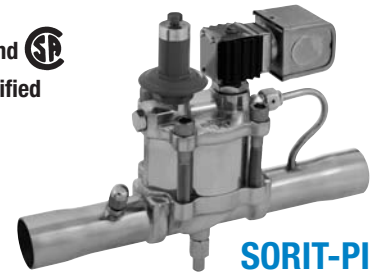

S)ORIT-PI

## Specifications

VALVE TYPE	PORT SIZE mm	ADJUSTMENT RANGE bar	STANDARD COIL RATINGS *MKC-1		CONNECTIONS ODF SOLDER Inches
			VOLTS/CYCLES	WATTS	
(S)ORIT-PI-2	12.7	0/6.90 or 5.17/10.3	24/50-60 120/50-60 208-240/50-60 120-208-240/50-60	10	5/8, 7/8, 1-1/8, 1-3/8
(S)ORIT-PI-3	19.1				7/8, 1-1/8, 1-3/8, 1-5/8
(S)ORIT-PI-4	25.4				1-1/8, 1-3/8, 1-5/8, 2-1/8
(S)ORIT-PI-5	31.8				1-3/8, 1-5/8, 2-1/8

\*Available with junction box or conduit boss at no extra charge. For voltage other than listed consult Bulletin 30-10.

## Capacities – kW

Capacities based on 15°C liquid temperature, 0°K superheat at the evaporator and 14°K superheat at the valve.

VALVE TYPE	EVAPORATOR TEMPERATURE °C	REFRIGERANT															
		22				134a				404A				507			
		0.03	0.1	0.4	0.7	0.03	0.1	0.4	0.7	0.03	0.1	0.4	0.7	0.03	0.1	0.4	0.7
(S)ORIT-PI-2	5	2.78	8.66	20.3	27.6	2.22	6.92	16.6	20.9	2.70	8.40	19.6	27.0	2.61	8.13	18.9	26.2
	-5	2.33	7.26	17.7	22.6	1.81	5.63	13.1	16.1	2.22	6.93	16.3	21.8	2.15	6.71	15.7	21.2
	-15	1.93	6.01	14.4	17.9	1.45	4.51	9.99	11.7	1.81	5.63	13.6	17.1	1.76	5.47	13.2	16.7
	-25	1.57	4.90	11.3	13.6	—	—	—	—	1.44	4.50	10.5	12.9	1.41	4.38	10.3	12.7
(S)ORIT-PI-3	5	3.55	20.3	40.1	53.6	2.84	16.3	32.3	40.9	3.45	19.7	38.7	52.3	3.33	19.0	37.4	50.7
	-5	2.98	17.1	34.3	44.0	2.31	13.3	25.6	31.8	2.84	16.3	32.0	42.3	2.75	15.8	31.0	41.2
	-15	2.47	14.2	27.9	35.2	1.85	10.7	19.7	23.5	2.31	13.3	26.3	33.4	2.24	12.9	25.6	32.6
	-25	2.01	11.6	22.0	27.1	—	—	—	—	1.85	10.7	20.5	25.5	1.80	10.4	20.1	25.0
(S)ORIT-PI-4	5	7.72	27.3	54.6	72.1	6.17	21.8	43.5	55.5	7.49	26.5	53.0	70.3	7.24	25.6	51.2	68.1
	-5	6.48	22.9	46.1	59.4	5.02	17.7	34.6	43.4	6.18	21.8	43.7	57.1	5.99	21.1	42.3	55.5
	-15	5.36	18.9	37.6	47.8	4.02	14.2	26.8	32.6	5.02	17.7	35.4	45.3	4.88	17.2	34.5	44.2
	-25	4.36	15.4	29.8	37.2	—	—	—	—	4.01	14.2	27.7	34.9	3.91	13.8	27.1	34.2
(S)ORIT-PI-5	5	22.0	42.2	83.1	108	17.6	33.6	65.2	83.6	21.3	41.0	80.9	105	20.6	39.6	78.3	102
	-5	18.4	35.4	69.1	89.3	14.3	27.2	52.1	65.8	17.6	33.7	66.1	85.7	17.0	32.7	64.2	83.3
	-15	15.3	29.2	56.4	72.1	11.4	21.6	40.5	49.8	14.3	27.3	53.1	68.2	13.9	26.6	51.7	66.6
	-25	12.4	23.6	44.9	56.4	—	—	—	—	11.4	21.8	41.7	52.8	11.1	21.2	40.8	51.7

## Refrigerant Liquid Temperature – Correction Factors

REFRIGERANT	LIQUID TEMPERATURE ENTERING VALVE °C											
	-15°	-10°	-5°	0°	5°	10°	15°	20°	30°	35°	40°	
	CORRECTION FACTOR, CF LIQUID TEMPERATURE											
R-22	1.21	1.17	1.14	1.11	1.07	1.04	1.00	0.96	0.91	0.87	0.84	
R-134a	1.25	1.21	1.17	1.14	1.09	1.05	1.00	0.95	0.89	0.84	0.81	
R-404A	1.31	1.27	1.22	1.16	1.12	1.06	1.00	0.94	0.86	0.79	0.74	
R-507	1.32	1.28	1.22	1.16	1.12	1.06	1.00	0.94	0.86	0.80	0.75	

\*ARI standard capacities are based on 38°C saturated liquid temperature. Use the correction factor for 40°C liquid temperature and the capacities at 5°C evaporator temperature to determine approximate ARI standard capacity ratings.

Example: The capacity of a (S)ORIT-PI-3 using R-22, evaporator temperature of -15°C, 0.1 bar pressure drop across the valve and a liquid temperature of 10°C, is equal to 14.2 x 1.04 = 14.8 kW.

## Installation

When installing these valves with solder connections, the internal parts should be protected from overheating by wrapping the valve with a wet cloth.

## (S)ORIT-PI Series – Valve Nomenclature/Ordering Instructions

<b>S</b>	<b>ORI</b>	<b>T</b>	<b>PI</b>	<b>2</b>	<b>7</b>	<b>S</b>	<b>E</b>	<b>0/100</b>	<b>120/50-60</b>
Solenoid Stop Feature (optional)	Valve Type: Open on Rise of Inlet Pressure	Pressure Tap on Inlet Connection	Piloted Internally	Port Size in 1/4 of an Inch	Fitting Size in 1/8 of an Inch	Solenoid Stop Feature (optional)	Electric Open Feature (optional)	Adjustment range psig*	Electrical specifications for Solenoid Stop Feature (optional)

\* Other pressure ranges are available.

For complete information consult your nearest Sporlan Wholesaler or email europecold@parker.com and request Bulletin 90-20-2 and 90-20-2A.



# ELECTRONIC TEMPERATURE CONTROL SYSTEMS

## Electric Expansion Valves

Sporlan Electric Expansion Valves (EEVs) are currently available in nominal R-410A capacities from 5 to 700 kW. Therefore, they are applicable on all the same types of systems found in the air conditioning and refrigeration industry as thermostatic expansion valves.

All Sporlan electric valves are designed for compatibility with all current halocarbon refrigerants, including CFCs, HCFCs, HFCs and R-410A. Specific system conditions will dictate which product is necessary to control the application. Details can be reviewed with the Sporlan Sales Engineer.

The ESX, SER, SEI and SEH are Electronically Operated Step Motor flow control valves, intended for the precise control of liquid refrigerant. Synchronized signals to the motor provide discrete angular movement, which translates into precise linear positioning of the valve piston. Valve pistons and ports are uniquely characterized, providing improved flow resolution and performance. The ESX, SER, SEI and SEH valves are easily interfaced with microprocessor based controllers, including Sporlan supplied controllers.

All Sporlan EEVs are rated for at least 42 bar MRP.

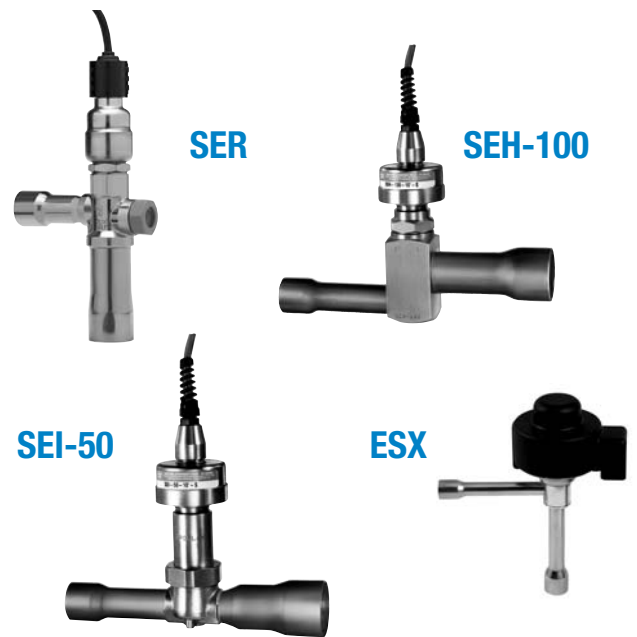

## Specifications

VALVE TYPE	INLET – Inches STANDARD CONNECTIONS In BOLD	OUTLET – Inches STANDARD CONNECTIONS In BOLD	CONFIGURATION	CABLE LENGTH – m STANDARD CONNECTIONS In BOLD
ESX 14	5/16 ODF, 3/8 ODF	5/16 ODF, 3/8 ODF, 1/2 ODF	Angle	1.5, <b>3</b>
ESX 18	5/16 ODF, 3/8 ODF	5/16 ODF, 3/8 ODF, 1/2 ODF	Angle	1.5, <b>3</b>
ESX 24	5/16 ODF, 3/8 ODF	5/16 ODF, 3/8 ODF, 1/2 ODF	Angle	1.5, <b>3</b>
SER 1.5*	<b>3/8</b> , 1/2, 5/8 ODF	3/8, <b>1/2</b> , 5/8	Angle	<b>3</b> , 12
SER 6*	3/8, <b>1/2</b> , 5/8 ODF	3/8, 1/2, <b>5/8</b> , 7/8	Angle	<b>3</b> , 12
SER 11*	3/8, 1/2, <b>5/8</b> ODF	1/2, 5/8, <b>7/8</b> , 1-1/8 ODF	Angle	<b>3</b> , 12
SER 20*	1/2, 5/8, <b>7/8</b> , 1-1/8 ODF	5/8, 7/8, 1-1/8, <b>1-3/8</b> ODF	Angle	<b>3</b> , 12
SEI 30*	5/8, 7/8, <b>1-1/8</b> ODF	5/8, 7/8, 1-1/8, <b>1-3/8</b> ODF	Angle	<b>3</b> , 6, 9, 12
SEI 50	7/8, <b>1-1/8</b> , 1-3/8 ODF	7/8, 1-1/8, <b>1-3/8</b> , 1-5/8 ODF	Straight through	<b>3</b> , 6, 9, 12
SEH 100	<b>1-1/8</b> , 1-3/8 ODF	1-3/8, <b>1-5/8</b> ODF	Straight through	<b>3</b> , 6, 9, 12
SEH 175	1-1/8, 1-3/8, <b>1-5/8</b> ODF	<b>2-1/8</b> ODF	Straight through	<b>3</b> , 6, 9, 12
SER G*	5/8 ODF	7/8 ODF	Angle	<b>3</b>
SER J	7/8 ODF	7/8 ODF	Angle	<b>3</b>
SER K	1-1/8 ODF	1-1/8 ODF	Angle	<b>3</b>

\* Suitable for bi-directional applications.

## Capacities – kW

VALVE TYPE	REFRIGERANT											
	134a			404A			407C			410A		
	5°C	-10°C	-20°C	5°C	-10°C	-20°C	5°C	-10°C	-20°C	5°C	-10°C	-20°C
ESX 14	3.2	3.6	3.4	2.8	3.0	2.9	3.9	4.3	4.1	5.4	6.0	5.8
ESX 18	5.7	6.3	6.0	5.0	5.3	5.1	6.9	7.6	7.2	9.7	10.5	10.2
ESX 24	11.5	12.6	12.1	10.0	10.7	10.1	13.8	15.1	14.5	19.3	21.1	20.5
SER 1.5*	3.7	4.1	3.9	3.3	3.5	3.3	4.5	4.9	4.7	6.3	6.9	6.7
SER 6*	15.0	16.5	15.7	13.0	13.9	13.2	18.0	19.7	18.9	25.2	27.5	26.7
SER 11*	27.5	30.2	28.9	23.8	25.5	24.1	33.1	36.1	34.6	46.2	50.3	49.0
SER 20*	49.9	55	52.5	43.3	46.4	43.9	60.2	65.6	62.9	83.9	91.5	89.1
SEI 30*	74.9	82.4	78.8	65.0	69.7	65.8	90.2	98.4	94.4	126	137	134
SEI 50	125	137	131	108	116	110	150	164	157	210	229	223
SEH 100	250	275	262	217	232	219	301	328	315	420	458	445
SEH 175	437	481	459	379	406	384	526	574	550	735	801	779
SER G*	66.3	73	69.8	57.5	61.7	58.3	79.9	87.2	83.6	112	122	118
SER J	119	131	126	104	111	105	144	157	150	201	219	213
SER K	216	238	228	188	201	190	261	284	273	420	458	445

\* Suitable for bi-directional applications.

# ELECTRONIC TEMPERATURE CONTROL SYSTEMS

## Specifications

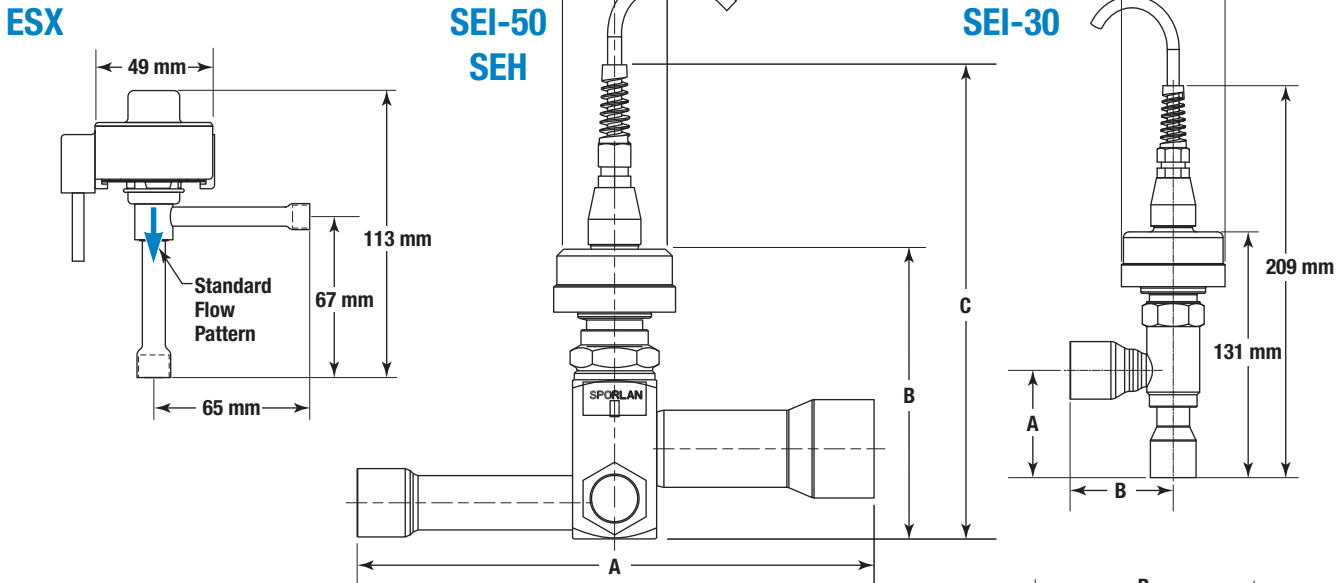

### Dimensions — Connections

VALVE TYPE	mm		
	A	B	C
SER 1.5	51	63	—
SER 6	51	58	—
SER 11	64	58	—
SER 20	66	61	—
SER G	90	76	96
SER J	90	83	96
SER K	94	86	99
SEI 30	56	71	—
SEI 50	205	126	209
SEH 100	237	131	215
SEH 175	215	133	216

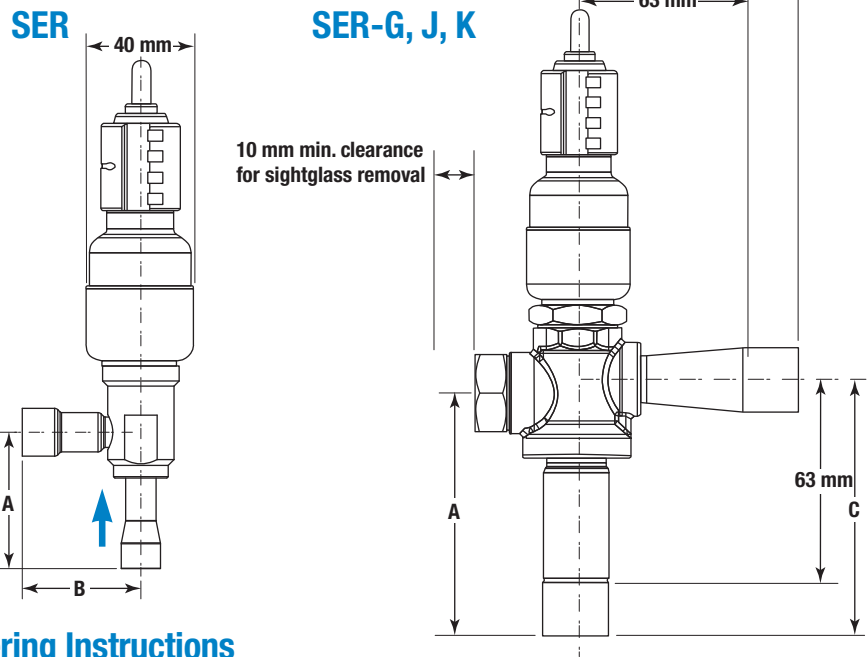

### ESX – Valve Nomenclature/Ordering Instructions

ESX	-14	B
Valve Model	Orifice Diameter 14 = 1.4 mm 18 = 1.8 mm 24 = 2.4 mm	Connections 5/16 x 5/16 ODF A 3/8 x 3/8 ODF B 3/8 x 1/2 ODF

### SEI, SEH(I) or SER(I) – Valve Nomenclature/Ordering Instructions

SEH	(I)	175	1-1/8"	x	2-1/8"	ODF	10	S
Valve Model	Indicating Sightglass optional (not available on SER, SEI)	Valve Nominal Capacity	Inlet Fitting 7/8", 1-3/8" and 1-5/8" available*		Outlet Fitting 1-3/8", 1-5/8" and 2-1/8" available*	Fitting type ODF only	Cable Length 10' standard, 30' and 40' available	Stripped and Tinned cable ends, Packard Weather PAK™ also available

\* Not all fitting sizes are available on all valves.  
For complete information consult your nearest Sporlan Wholesaler or email [europelcold@parker.com](mailto:europelcold@parker.com) and request Bulletin 100-20-1 and 100-20-2.

# ELECTRONIC TEMPERATURE CONTROL SYSTEMS

## Electric Evaporator Pressure Regulating Valves

The CDS valves are designed for more precise and energy efficient control of temperatures in evaporators. Proper temperature is obtained by regulating refrigerant flow in the evaporator in response to signals generated by an electronic controller and sensor combination. The valves are built around balanced ports, which allows input power of only 4 watts, less than one quarter of the power used by older heat motor and analog designs. When not actively stepping, power to the motor is removed for further energy savings. The step motors used are standard 12-volt DC bipolar designs, which in concert with the integral gear reduction, give the valves unsurpassed accuracy and repeatability over the entire



operating range. Since the valves are powered from an external controller, no pilot lines or high to low side bleeds are required. The properly applied CDS valve and controller can replace standard mechanical evaporator pressure regulators (EPR), suction stop solenoid valves, and conventional thermostats.

With different seating materials, CDS-16 valves may be applied as heat reclaim, head pressure control, or liquid line differential valves. CDS-9 and -17 are suitable for these applications as supplied. Contact Sporlan for more information.

Due to the step motor design, the CDS series are the first evaporator control valves that may be sized to contribute NO additional pressure drop to the suction line.

Simplified cartridge design allows all moving parts to be replaced as a unit. Only the valve body is left in the line. This will allow maintenance or repair without unsweating the entire valve.

## Specifications

(Standard Connections and Cable Lengths are in **BOLD** type.)

TYPE	CONNECTIONS ODF SOLDER – Inches	CONFIGURATION	CABLE LENGTH m	CABLE ENDS
CDS-4	1/2, 5/8, 7/8	Straight Through	<b>3</b>	S-Stripped and Tinned
CDS-7	5/8, 7/8, 1-1/8, 1-3/8	Straight Through	<b>3</b>	
CDS-9	5/8, 7/8, 1-1/8, 1-3/8	Angle or Straight Through	<b>3</b>	
CDS-16	<b>1-3/8</b>	Angle	<b>3</b>	
CDS-17	1-3/8, <b>1-5/8</b> , 2-1/8	Straight Through	<b>3</b>	

## Capacities – kW

TYPE	EVAPO-RATOR TEMP. °C	REFRIGERANT																							
		134a					404A/507					407C					410A								
		PRESSURE DROP ACROSS VALVE – bar																							
		0.03	0.06	0.1	0.2	0.4	0.7	0.03	0.06	0.1	0.2	0.4	0.7	0.03	0.06	0.1	0.2	0.4	0.7	0.03	0.06	0.1	0.2	0.4	0.7
CDS-4	0	2.62	3.68	4.72	6.63	9.10	11.4	3.07	4.31	5.53	7.76	10.9	14.4	3.22	4.52	5.8	8.14	11.5	14.7	4.17	5.86	7.52	10.6	14.8	19.5
	-10	2.12	2.98	3.83	5.30	7.09	8.60	2.53	3.55	4.55	6.39	9.06	11.6	2.63	3.69	4.74	6.65	9.18	11.5	3.49	4.9	6.30	8.84	12.4	16.3
	-20	1.69	2.37	3.01	4.09	5.3	6.07	2.05	2.88	3.69	5.18	7.17	9.01	2.11	2.97	3.81	5.29	7.11	8.67	2.88	4.04	5.19	7.28	10.2	13.0
	-30	1.31	1.82	2.29	3.03	3.70	3.83	1.63	2.29	2.94	4.09	5.51	6.72	1.67	2.34	2.97	4.04	5.27	6.09	2.33	3.27	4.20	5.89	8.04	10.0
CDS-7	0	7.49	10.4	13.3	18.3	24.5	29.5	8.69	12.0	15.3	21.1	29.2	39.3	9.21	12.7	16.2	22.4	31.6	39.4	11.8	16.4	20.8	28.8	39.8	51.7
	-10	6.02	8.41	10.7	14.5	18.7	21.1	7.20	9.97	12.7	17.5	24.9	31.0	7.51	10.5	13.3	18.4	24.8	30.1	9.98	13.8	17.5	24.2	33.5	44.5
	-20	4.75	6.59	8.29	11.0	13.3	13.8	5.87	8.14	10.3	14.3	19.4	23.5	5.99	8.38	10.6	14.5	18.8	21.6	8.25	11.5	14.5	20.1	28.0	34.8
	-30	3.65	5.01	6.21	7.85	8.53	8.53	4.64	6.49	8.24	11.2	14.6	16.7	4.68	6.50	8.19	10.9	13.3	13.9	6.63	9.29	11.9	16.3	21.7	25.9
CDS-9	0	11.0	15.5	19.8	27.5	37.5	46.6	13.0	18.0	22.9	31.9	44.3	59.5	13.6	19.0	24.2	33.7	47.5	60.5	17.6	24.5	31.2	43.4	60.3	78.6
	-10	8.88	12.5	15.9	21.9	29.1	34.9	10.7	14.9	19.0	26.4	37.4	47.6	11.1	15.6	19.9	27.7	37.8	47.3	14.8	20.6	26.3	36.5	50.7	67.4
	-20	7.02	9.80	12.4	16.8	21.6	24.3	8.65	12.1	15.5	21.5	29.6	36.9	8.84	12.4	15.8	21.8	29.2	35.3	12.2	17.1	21.8	30.2	42.3	53.7
	-30	5.42	7.51	9.44	12.4	14.9	15.2	6.84	9.60	12.3	16.9	22.6	27.4	6.92	9.67	12.3	16.6	21.5	24.4	9.77	13.7	17.6	24.4	33.1	41.0
CDS-16	0	18.5	25.9	32.8	45.3	60.1	71.5	21.5	29.7	37.8	52.2	72.1	96.4	22.8	31.5	40.0	55.3	77.6	96.4	29.3	40.5	51.4	71.1	98.3	128
	-10	14.9	20.7	26.3	35.5	45.5	50.7	17.8	24.7	31.3	43.3	61.0	75.9	18.5	26.0	33.0	45.6	60.9	73.2	24.7	34.2	43.4	59.9	82.8	109
	-20	11.7	16.2	20.4	26.8	32.2	32.8	14.5	20.2	25.6	35.4	47.6	57.2	14.8	20.7	26.2	35.5	45.8	51.9	20.4	28.4	36.0	49.8	68.8	85.1
	-30	9.01	12.3	15.2	19.0	20.3	20.3	11.4	16.0	20.3	27.5	35.5	40.3	11.5	16.0	20.1	26.6	32.2	33.1	16.4	22.9	29.2	40.0	53.0	62.8
CDS-17	0	20.0	27.8	35.5	49.4	67.6	83.5	23.2	32.3	41.1	57.3	79.7	108	24.4	34.0	43.4	60.4	85.9	109	31.6	43.9	56.0	78.0	109	142
	-10	16.1	22.6	28.8	39.5	52.3	62.1	19.2	26.7	34.0	47.3	67.6	85.8	20.1	27.9	35.6	49.6	68.2	84.8	26.5	36.9	47.1	65.5	91.2	122
	-20	12.7	17.8	22.5	30.3	38.6	42.6	15.6	21.7	27.7	38.6	53.3	66.3	16.0	22.5	28.7	39.4	52.5	62.9	21.9	30.5	39.0	54.2	76.4	96.6
	-30	9.83	13.6	17.0	22.2	26.2	26.5	12.4	17.4	22.2	30.5	40.7	48.8	12.6	17.5	22.2	30.0	38.4	42.9	17.7	24.8	31.7	44.1	59.7	73.6

Capacities based on 16°C liquid and 14°C superheated vapor.

REFRIGERANT	LIQUID TEMPERATURE ENTERING TEV °C										
	-10°	-5°	0°	5°	10°	15°	20°	25°	30°	35°	40°
	CORRECTION FACTOR, CF LIQUID TEMPERATURE										
134a	1.21	1.17	1.13	1.09	1.05	1.01	0.97	0.92	0.88	0.84	0.79
404A/507	1.27	1.22	1.17	1.12	1.07	1.01	0.96	0.90	0.84	0.78	0.72
407C	1.21	1.17	1.13	1.09	1.05	1.01	0.97	0.92	0.88	0.84	0.79
410A	1.21	1.17	1.13	1.09	1.05	1.01	0.97	0.92	0.87	0.83	0.78

Use the correction factor for 38°C liquid temperature and the capacities at 5°C evaporator temperature to determine ARI standard capacity ratings.

Example: The capacity of a CDS-7 using R-407C, evaporator temperature of -25°C, 0.06 bar pressure drop across the valve and a liquid temperature of 10°C is equal to (7.41 x 1.05) 7.78 kilowatts.

These factors correct for net refrigerating effect and are based on an average temperature of -15°C. However, they may be used for any evaporator temperature from -30°C to 5°C since the variation in the actual factors across this range is insignificant.

# ELECTRONIC TEMPERATURE CONTROL SYSTEMS

## CDS-4

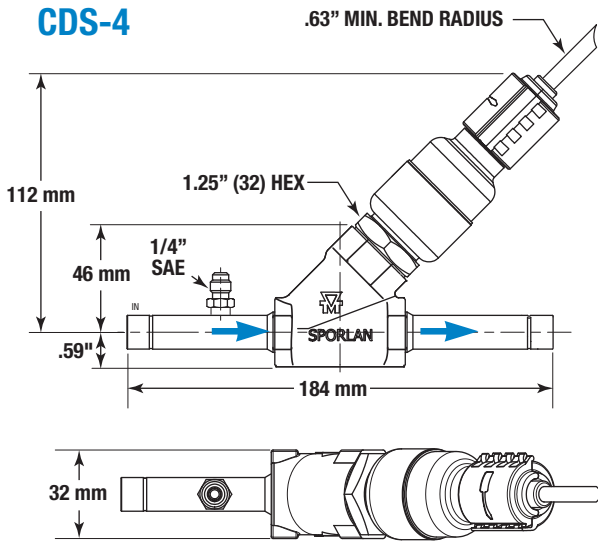

## CDS-7

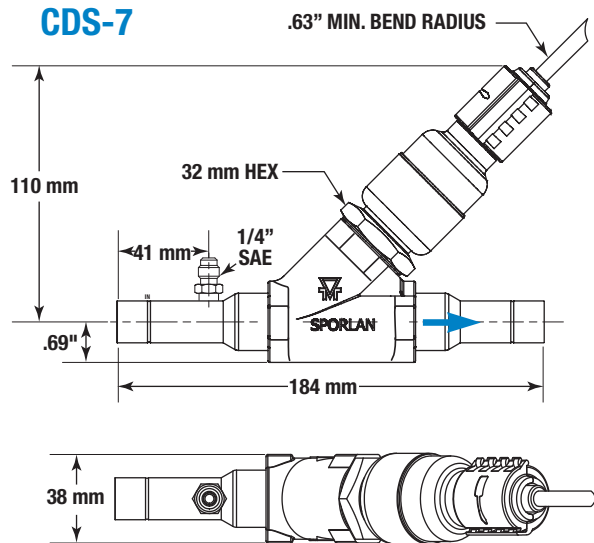

## CDS-9

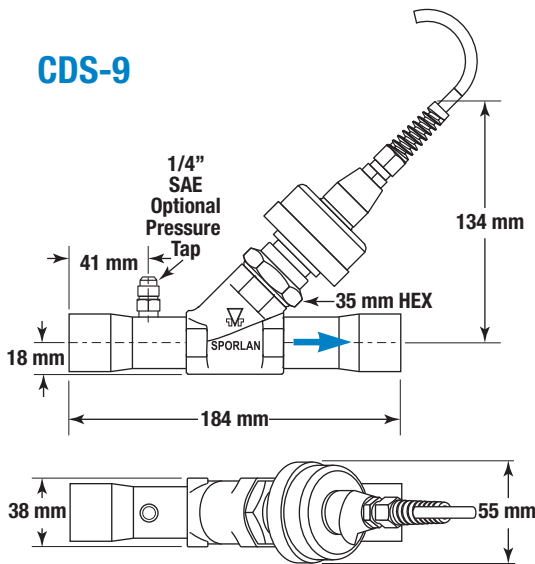

## CDS-17

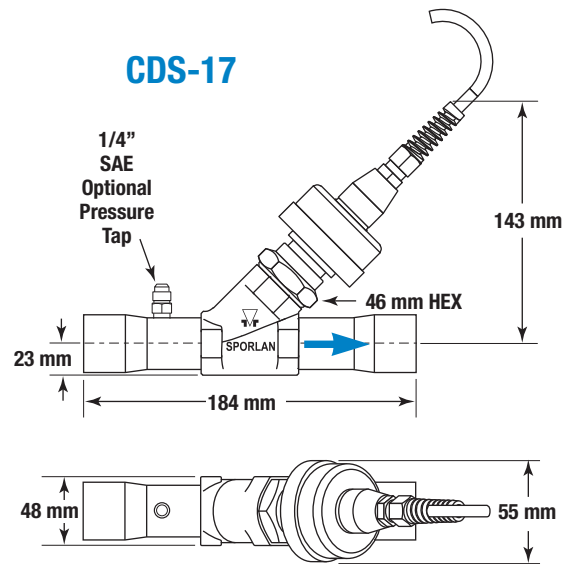

## CDS-16

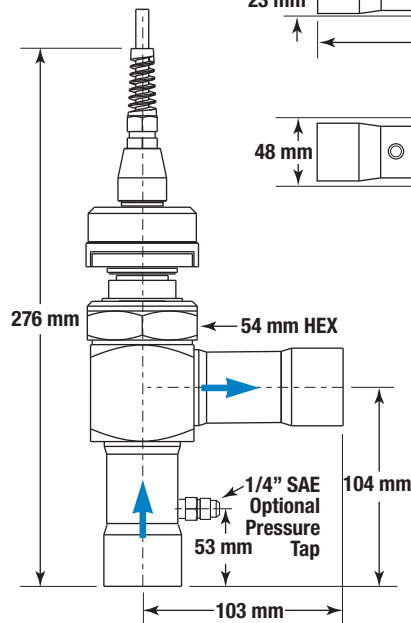

### CDS – Valve Nomenclature/Ordering Instructions

The CDS-16 is the only angled valve. The CDS-4, CDS-7, CDS-9 and CDS-17 are straight through valves.

CDS	T	17	1-3/8 x 1-3/8 ODF	20	S	Angle
Controls Discharge Stepmotor	Optional Inlet Pressure Tap	Model Number	Fitting Size	Cable Length 20' standard, others available	S = Stripped and tinned cable ends. Custom Connectors available	Used only if angled configuration CDS-16 Only

# ELECTRONIC TEMPERATURE CONTROL SYSTEMS

## Electric Discharge Gas Bypass Valves

SDR series valves are Step Discharge Regulators, or electrically operated discharge gas bypass valves. Unlike previous mechanical discharge gas bypass valves that only control a downstream pressure, the SDR series offers direct temperature control of air or liquid. The valves use the same 12 DC bipolar step motor as all other Sporlan step motor operated valves, including the CDS valves above. Balanced pistons and ports, uniquely characterized for hot gas flow, have been incorporated into the design. Seating materials, motors and gears have all been laboratory and field proven in high temperature gas applications.

With capacities up to 25 nominal R-22 tons, the SDR series is suitable for use in small process chillers and environmental chambers, as well as large direct expansion air conditioning applications. The valves may be controlled by third party controllers or by the Sporlan TCB interface/controller shown below. SDR valves are normally installed in the same manner as mechanical discharge gas bypass valves; in a bypass branch of

the discharge gas line. The valves may be piped to feed into the evaporator at the distributor, downstream of the evaporator, or at the compressor suction. Contact Sporlan for additional piping recommendations. When applied with a third party controller or DDC building management system, the SDR can be used with the IB or TCB as an interface to the existing system. For stand-alone control, the SDR and TCB with sensor will allow close temperature control of the air or liquid stream. See the section below for information on the TCB and IB.

The SDR valves are tight seating and will act as solenoid valves for shut off.

## Specifications

TYPE	CONNECTIONS Inches	CONFIGURATION	CABLE LENGTH Feet	CABLE ENDS
SDR-3	3/8, 1/2, 5/8 ODF	Angle	10, 20, 30, 40	S-Stripped and Tinned
SDR-3X	3/8, 1/2, 5/8 ODF	Angle		
SDR-4	7/8, 1-1/8 ODF	Straight through		

## Discharge Bypass Valve Capacities – kW

REFRIGERANT	VALVE TYPE	MINIMUM ALLOWABLE EVAPORATOR TEMPERATURE AT REDUCED LOAD °C																	
		5°C			3°C			-7°C			-18°C			-29°C			-40°C		
		26	38	49	26	38	49	26	38	49	26	38	49	26	38	49	26	38	49
22	SDR-3	18.9	24.2	30.5	18.9	23.5	29.1	18.6	23.5	28.4	17.2	21.7	26.6	16.1	20.3	24.9	15.1	19.3	23.8
	SDR-3X	34.3	44.1	55.7	34.7	44.5	56.0	34.7	44.5	56.0	35.0	44.8	56.7	35.4	45.5	57.4	35.7	46.2	58.1
	SDR-4	62.7	88.2	122	67.9	92.4	125	69.3	98.0	127	73.2	98.4	130	75.6	100	131	77.0	104	132
134a	SDR-3	13.3	16.5	19.3	12.6	15.4	18.2	12.3	14.7	17.9	10.9	13.3	16.5	9.8	12.3	15.4	9.1	11.6	14.7
	SDR-3X	24.1	30.0	35.2	23.1	29.2	35.1	22.9	27.9	35.3	22.1	27.5	35.1	21.5	27.5	35.6	21.6	27.7	35.9
	SDR-4	46.6	64.4	83.3	49.7	66.9	85.4	50.8	67.6	86.1	53.2	69.7	87.5	54.6	70.7	88.6	55.3	71.4	89.3
404/507	SDR-3	21.0	25.6	30.1	22.1	25.9	29.8	21.4	25.2	29.4	19.6	23.5	27.7	17.5	21.0	26.3	16.8	20.3	25.2
	SDR-3X	38.1	46.7	55.0	40.4	49.1	57.3	39.9	47.8	58.1	40.0	48.4	58.9	38.4	47.1	60.6	39.9	48.7	61.5
	SDR-4	69.7	91.7	111	80.9	104	126	83.0	105	127	87.5	109	130	85.1	104	123	93.1	115	136
407C	SDR-3	18.9	23.1	28.7	18.2	23.1	27.3	17.9	21.7	27.0	16.5	20.3	25.2	15.1	18.9	23.8	14.0	17.9	22.8
	SDR-3X	34.3	42.2	52.5	33.4	43.8	52.6	33.3	41.1	53.2	33.6	41.9	53.7	33.0	42.4	55.0	33.2	42.8	55.5
	SDR-4	64.1	87.5	119	69.3	97.3	123	71.1	96.3	125	75.6	97.3	128	78.4	100	132	80.5	103	135
410A	SDR-3	31.9	39.6	47.7	31.9	39.6	47.7	31.9	39.6	47.6	31.9	39.6	47.7	31.9	39.6	47.7	—	—	—
	SDR-3X	57.0	71.1	85.6	57.3	71.1	85.6	57.3	71.1	85.6	57.3	71.1	85.6	57.3	71.1	85.6	—	—	—
	SDR-4	104.0	139.8	174.0	112.9	146.5	179.4	115.7	148.7	185.6	122.4	154.1	185.9	126.3	157.5	188.9	—	—	—

Note: Capacities are based on discharge temperature 28°C above isentropic compression, 55°C condensing temperature, 0°C subcooling, 13°C superheat at the compressor and includes both the hot gas bypassed and the liquid refrigerant for desuperheating, regardless of whether the liquid is fed through the system thermostatic expansion valve or auxiliary desuperheating expansion valve.

For complete information consult your nearest Sporlan Wholesaler or email [europelcold@parker.com](mailto:europelcold@parker.com) and request Bulletin 100-60.

## Dimensions

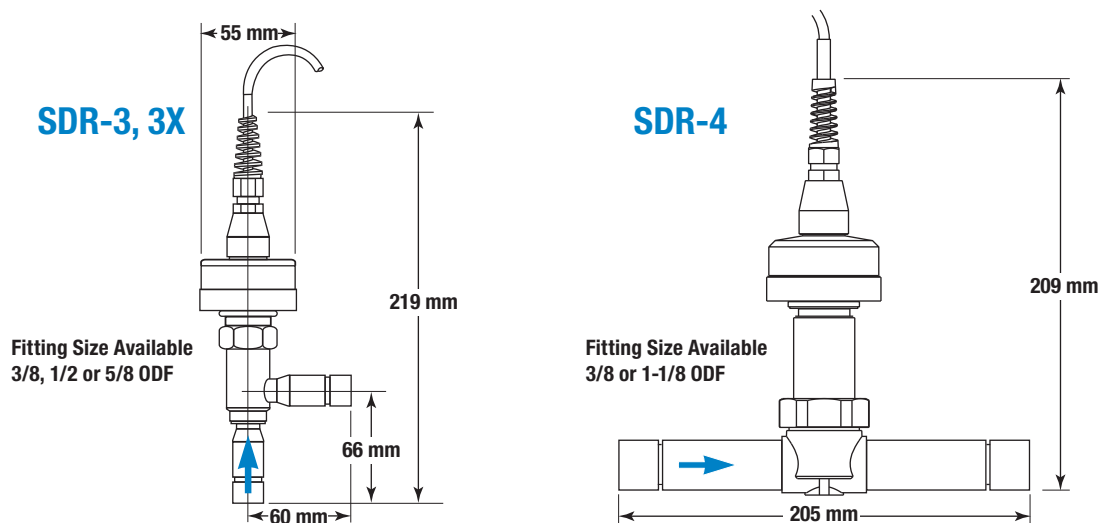

## SDR – Valve Nomenclature/Ordering Instructions

<b>S</b>	<b>DR</b>	<b>4</b>	<b>7/8 x 7/8</b>	<b>10</b>	<b>S</b>
Step Motor Operated	Discharge Regulator	Nominal Size 3 or 4 Available	Connections ODF SDR-3, 3x - 3/8, 1/2, 5/8 SDR-4 - 7/8, 1-1/8	Cable Length 10' standard, 20,30,40 also available	S = Stripped and tinned cable ends. Custom Connectors available



# ELECTRONIC TEMPERATURE CONTROL SYSTEMS

## Electric Valve Controllers

Sporlan offers a variety of controllers for use in refrigeration and air conditioning systems. Applications include self-contained food service equipment, cold rooms and chillers. With over 80 different models, Sporlan can satisfy almost any customer requirement.

Small, standalone controllers include the compact Kelvin II and larger Superheat and Refrigeration controllers. All provide true pressure/temperature superheat control of any system using Sporlan Electric Expansion Valves (EEVs). Chiller controllers offer true pressure/temperature superheat control for two Sporlan EEVs and are available in Fahrenheit/psi or Celsius/Bar versions.

Sporlan offers purpose built controllers, such as subcoolers for supermarket refrigeration, head pressure, temperature only and pressure only.

Cold rooms can be controlled with RCS, which has onboard remote communication, and master-slave settings for defrost control. Included real time clocks allow defrost initialization times to be set precisely and relays allow control of fans, solenoids, alarms and compressors. Many of the controllers can be customized for specific needs, or supplied in an enclosure.

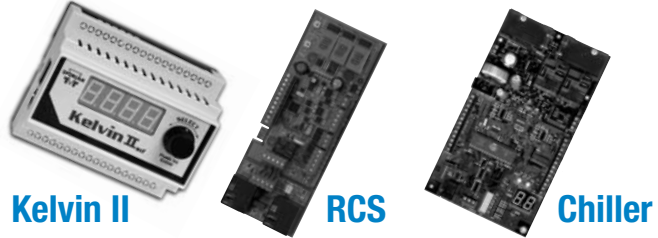

CONTROLLER PACKAGES	DISPLAY	COMMUNICATION	RELAYS	REFRIGERANTS	INPUTS*	VALVES
<b>Kelvin IIs</b>	No	RS-485	None	R-22, R-134a, R-404A, R-507, R-410A, R-407C Not all refrigerants are available on all models.	1 Press, 3 Temp.	1 SER, SEI, ESX, SEHI, SDR or CDS
<b>Kelvin IIsd</b>	4 Alphanumeric	RS-485, USB	None		1 Press, 3 Temp.	1 SER, SEI, ESX, SEHI, SDR, CDS, or 2 PWM
<b>RCS</b>	3 Alphanumeric	RS-485	Four		1 Press, 4 Temp.	1 SER, SEI, ESX or SEHI
<b>Subcooler</b>	2 Numeric	None	None		1 Press, 2 Temp.	1 SER, SEI, ESX or SEHI
<b>Chiller</b>	2 Numeric	None	Three		1 Press, 4 Temp.	2 SER, SEI, ESX or SEHI
<b>Chiller European</b>	2 Numeric (C°/Bar)	None	Three		1 Press, 4 Temp.	2 SER, SEI, ESX or SEHI
<b>Pressure</b>	2 Numeric	None	None		1 Press	1 CDS or 1 SDR
<b>Dual Pressure Control</b>	2 Numeric	None	None		2 Press	2 CDS or 2 SDR or 1 of each
<b>Temperature Control</b>	2 Numeric	None	None		1 Temperature	1 CDS or 1 SDR
<b>Dual Temp. Control</b>	2 Numeric	None	None		2 Temperature	2 CDS or 2 SDR or 1 of each
<b>Superheat</b>	2 Numeric	None	None		1 Press, 2 Temp.	1 SER, SEI, ESX, or SEHI
<b>Superheat Low Temp.</b>	2 Numeric	None	None		1 Press, 2 Temp.	1 SER, SEI, ESX, or SEHI
<b>Refrigeration</b>	2 Numeric	None	None		1 Press, 2 Temp.	1 SER, SEI, ESX, or SEHI

Notes: \* See accessories below, only Sporlan approved sensors may be used. \*\* All products control temperature, other functions not available on all models.

ACCESSORIES	ITEM NUMBERS	APPLICATION
0-150 psig Pressure Transducer 5' Cable (Green Color Code)	953091	RCS and Kelvin except R-410A
0-300 psig Pressure Transducer 5' Cable (Black Color Code)	952740	All except TCB, IB
0-150 psig Pressure Transducer 10' Cable (Green Color Code)	953092	RCS and Kelvin except R-410A
0-300 psig Pressure Transducer 10' Cable (Black Color Code)	952503	All except TCB, IB
0-500 psig Pressure Transducer 10' Cable (Yellow Color Code)	952505	Head Pressure and CO <sub>2</sub> Applications only
Surface Sensor - 2K (Black Color Code)	952662	All except RCS and Kelvin
Surface Sensor - 3K (White Color Code)	952551	RCS and Kelvin
Well Sensor	952795	All except IB, TCB less Potentiometer, RCS, and Kelvin
Air Sensor	952669	All except IB, TCB less Potentiometer, RCS, and Kelvin
SMA-12 Valve Actuator	953276	All 12 Volt DC Step Motor Valves

## TCB Temperature Control Board/IB Interface Board

The TCB interface/controller allows all Sporlan step motors to be modulated in response to an externally generated signal. The IB and TCB accept a 4-20 milliamp, or 0-10 volt DC inputs and stroke the valve proportionately to that signal. The TCB and IB allow use of the CDS or SDR valves with an existing DDC system or other generic temperature controller for hot gas bypass, evaporator temperature, or reclaim applications. While the TCB and IB will control Sporlan's line of SEI and SEH step motor electric expansion valves, an external signal must be generated in response to superheat and not simply temperature.



When the TCB is purchased with optional set point potentiometer and sensor, the TCB becomes a stand alone single point temperature control for the CDS or SDR valves. The sensor is installed in the air stream or affixed to the pipe containing the liquid to be controlled. The potentiometer is set to the temperature desired, and the TCB will modulate the valve to maintain tight temperature control. The TCB can be configured to "close on rise" or "open on rise" and requires

only an external 24 volt AC 40 VA power source. The TCB incorporates separate "pump down", "open valve", and "close valve" contacts for use with external relays to allow even greater control choices. The TCB and IB have screw terminals for easy connections, and should be mounted in a control panel or other enclosure.

## SMA-12 Step Motor Actuator

The SMA-12 is designed to diagnose systems with step motor valves by proving operation of the step motor. The unit is powered by two 9 volt alkaline batteries and will power any standard 12-volt DC bipolar step motor. Step rate is selectable at 1, 50, 100 or 200 steps per second and will stroke the motor in both directions. Red lamps indicate continuity of the motor windings and battery power, and binding posts provide quick connection of the motor leads. In the event of a controller failure, the SMA-12 can manually open or close the valve or step it to any position. The SMA-12 is the basic troubleshooting



ITEM NUMBER	DESCRIPTION	CONNECTOR
953276	SMA-12	Binding Post
953277	SMA-12 w/Pigtail	Packard Pigtail Item #958112

INTERFACE BOARDS	INPUT	VALVES*
<b>TCB</b>	4-20 ma, 0-10 VDC	SDR, CDS
<b>TCB with Potentiometer</b>	Temperature Sensor	SDR, CDS
<b>IB-ESX</b>	4-20 ma, 0-10 VDC	ESX
<b>IB-1</b>	4-20 ma, 0-10 VDC	SDR-3
<b>IB-3</b>	4-20 ma, 0-10 VDC	SDR-3, 3X
<b>IB-6</b>	4-20 ma, 0-10 VDC	SDR-4, CDS-9, -16, -17, Y1177

\* Interface boards may be used with electric expansion valves SER, SEI, SEHI, ESX only when used with external superheat controllers. For complete information consult your nearest Sporlan Wholesaler or email europecold@parker.com and request Bulletin 100-50-1 and 100-50-2.



# OIL LEVEL CONTROL SYSTEM

Sporlan's Oil Level Control System Components were developed to offer the refrigeration industry an oil level control system of the highest quality. The heart of the system is the Oil Level Control which when matched with the Oil Reservoir and Oil Differential Check Valve maintains a minimum oil level in the compressor crankcase during all phases of system operation.

## Oil Reservoirs

Sporlan oil reservoirs are holding vessels for stand-by oil necessary for the operation of a commercial refrigeration or air conditioning system. The oil reservoir is shipped with service valves so the vessel can be isolated from the rest of the system.

## Features and Benefits

- Sightglass ports with float ball indicators for oil level monitoring
- 3/8" male flare rotalock valves shipped with oil reservoir allow for easy adjustment when piping into system
- 3/8" male flare vent port – for connection to the suction line
- Mounting studs and brackets
- 35 bar maximum working pressure
- Powder coating passes 500 hour ASTM salt spray



## Oil Differential Check Valve Types OCV-5, OCV-10, OCV-20 and OCV-30

The Sporlan Oil Level Differential Check Valve (OCV) is installed on the 3/8" SAE fitting on top of the OR-1-1/2, and allows pressure to be relieved from the reservoir to the suction as required to maintain a pressure in the reservoir at a preset level above the suction pressure. The pressure differential created by the OCV assures oil flow from the reservoir to the Oil Level Control providing there is adequate oil in the reservoir.

The OCV will only relieve pressure from the reservoir in excess of its fixed set point. Systems with fluctuating suction pressure as a result of compressor unloaders, staging or other suction line controls must be fitted with an OCV with a differential greater than the suction pressure fluctuation to assure oil flow from the oil reservoir through the oil level control to the compressor crankcase.

Sporlan offers OCV's with a 0.35 bar, 0.7 bar and 1.4 bar fixed differential setting. However, Sporlan recommends the use of an OCV-20 or OCV-30 on all field built up applications.

MODEL NO.	PRESSURE DIFFERENTIAL SETTING – bar
OCV-5	0.35
OCV-10	0.70
OCV-20	1.4
OCV-30	2.1

## Specifications

MODEL NO.	TOTAL CAPACITY liters	'A' CAPACITY liters	'B' CAPACITY liters	NUMBER of SIGHT-GLASSES	LENGTH mm	SHELL DIAMETER mm
POR-2	7.6	2.8	2.8	2	457	152
POR-3	11.4	2.8	5.7	3	584	152
POR-4	15.1	2.8	10.4	3	914	152

'A' capacity is the capacity to the first sightglass.

'B' capacity is the capacity **between** the two sightglasses for the POR-2 and the **top and bottom** sightglasses for the POR-3 and POR-4.

## Oil Level Controls

The purpose of the Sporlan Oil Level Control is to regulate the flow of oil to the compressor crankcase to maintain a minimum oil level as specified by the compressor manufacturer for any given application. The Oil Level Control is adjustable between 1/2 sightglass and 1/4 sightglass at any pressure differential between 0.35 and 6.2 bar. As the level of oil is lowered in the compressor crankcase by being pumped out, the float of the Oil Level Control is lowered and opens a needle valve allowing oil to flow from the oil reservoir to the compressor crankcase.



**OL-60XH**

UL and SP  
Listed

## Selection & Specifications

MODEL NUMBER	PRODUCT TYPE	FLANGE TYPE	COMPRESSOR MANUFACTURER and MODEL	CONFIGURATION TOP VIEW
OL-60CH	6.2 bar Max Differential	3 bolt	See page 61 for compressor adaptor requirements.	
OL-60XH		3 bolt		
OL-60ZH		4 bolt		
OL-60FH		3 bolt		
OL-60HH-6		3 bolt		
OL-60NH-2		3 bolt		
S-OL	Sightglass	Included with adaptor kits on page 61 (except AOL-R) or may be purchased separately.		

27.5 bar M.R.P.

For complete information consult your nearest Sporlan Wholesaler or email [europocold@parker.com](mailto:europocold@parker.com) and request Bulletin 110-10 and 110-10-1.

# OIL LEVEL CONTROL SYSTEM

## Compressor Adaptor Requirements

COMPRESSOR MANUFACTURER	COMPRESSOR MODEL NUMBER	COMPRESSOR ATTACHMENT PATTERN	SPORLAN ADAPTOR KIT NUMBER	SEALING METHOD	SIGHTGLASS
Bitzer	2 KC, 2JC, 2HC, 2GC, 2 FC, 2EC, 2DC, 2CC, 4FC, 4EC, 4DC, 4CC	1-1/8" Thread	AOL-MA/TE	Use seal provided	Use sightglass provided with adaptor
	4VC, 4TC, 4PC, 4NC	3 Bolt, 1-7/8" B.C. (47.6 mm B.C.)	None	Use seal provided	Use sightglass from compressor
	4J, 4H, 4G, 6J, 6H, 6G, 6F	4 Bolt, 50 mm B.C.	None with the OL-60ZH control	Use seal provided with control	Use sightglass from compressor
	8GC, 8FC	3 Bolt, 1-7/8" B.C. (47.6 mm B.C.)	AOL-R-1	Use seal provided	Use sightglass from compressor
Bock	HA3-5, HG3-5, AM/F2-5	4 Bolt, 50 mm B.C.	AOL-BO Q	Use Teflon tape	Use sightglass provided with adaptor
	F...		AOL-R-1	Use seal provided	Use sightglass from compressor
Bristol	—	15/16" – 20 Thread	AOL-BR/TR	Use seal provided	Use sightglass provided with adaptor
Carrier	EA, ER	3 Bolt, 1-7/8" B.C. (47.6 mm B.C.)	AOL-R-1	Use seal provided	Use sightglass from compressor
	6E Front	3 Bolt, 1-7/8" B.C. (47.6 mm B.C.)	None		Use sightglass from compressor
	DA, DR, 5F, 5H, 6D, 6E	1-1/2" – 18 Thread	AOL-C		Use sightglass provided with adaptor
Copeland	Over 17 kW	3 Bolt, 1-7/8" B.C. (47.6 mm B.C.)	AOL-R-1	Use seal provided	Use sightglass from compressor
	Under 3.7 kW W	1-1/8" – 12 Thread	AOL-A	Use seal from compressor	Use sightglass provided with adaptor
	8R, 3D Front, 2D, 4D, 6D	3 Bolt, 1-7/8" B.C.(47.6 mm B.C.)	AOL-R-1	Use seal provided	Use sightglass from compressor
	8D	3 Bolt, 1-7/8" B.C.(47.6 mm B.C.)	Use control with standard length arms with AOL-R-1 adaptor. Use sightglass from compressor		
Dorin	4 cyc-15 HP	3 Bolt, 1-7/8" B.C.(47.6 mm B.C.)	Contact Sporlan		
Dunham-Bush	Big 4	3 Bolt, 1-7/8" B.C.(47.6 mm B.C.)	AOL-R-1	Use seal provided	Use sightglass from compressor
Fracold	All models	3 Bolt, 1-7/8" B.C.(47.6 mm B.C.)	AOL-R-1	Use seal provided	Use sightglass from compressor
Maneurop	MT..., LT...	1-1/8" – 18 Thread	AOL-MA/TE	Use seal provided	Use sightglass provided with adaptor
Prestcold	E, C	42 mm Thread	AOL-P	Use Teflon tape	Use sightglass provided with adaptor
Tecumseh	P, R, S, PA, RA, SA, CK, CM, CH, CG	1-1/8" – 12 Thread	AOL-A	Use seal from compressor	Use sightglass provided with adaptor
	—	1-1/8" – 18 Thread	AOL-MA/TE	Use seal provided	
Trane	M, R	3 Bolt, 1-7/8" B.C.(47.6 mm B.C.)	AOL-R-1	Use seal provided	Use sightglass from compressor
	K	3/4" NPT	AOL-K-1	Use Teflon tape	Use sightglass provided with adaptor
	—	15/16" – 20 Thread	AOL-BR/TR	Use seal provided	
York	GC, GS, JS	3 Bolt, 1-7/8" B.C.(47.6 mm B.C.)	AOL-R-1	Use seal provided	Use sightglass from compressor
<b>Sporlan Sightglass S-OL</b> Provided with all adaptor kits except the AOL-R-1, but can be purchased separately in kit form.			K-OL Kit	Kit includes: S-OL sightglass, quad ring, O-ring, 3 screws, and 3 locknuts.	

Note: Shipping wt. is 1.8 kg for oil level controls and 0.46 kg for adaptors.

1 The OL-60ZH control is a possible option on select models. Use sightglass from compressor.

2 Some compressor models have a smaller diameter port than the arm diameter of the oil level control. This situation can mislead the control in the amount of oil that is actually in the compressor. It is advisable the selection and adjustment of the control be reviewed in this situation.



## SERIES OIL FILTER

### Design Benefits

- Virtually eliminates the need for oil changes due to suspended particulate in circulation
- Unsurpassed filtering efficiency  
99% removal of 3 micron sized particles  
98% removal of 2 micron sized particles
- Element utilizes a pleated design for maximum surface area
- Unsurpassed filtration capacities
- High flow capacities with low pressure drop
- Filter element utilizes an O-ring seal
- Inert microglass filter material ensures lubricant compatibility
- Dimensions allow for easy replacement of current filter

The Sporlan Catch-All or SF-283-F Suction Filter has been used for many years as an oil filter in refrigeration rack systems with mineral or alkylbenzene oil.



With the use of the new polyolester (POE) oils, system chemistry changed. Unlike mineral and alkylbenzene oils, POE oil has solvent-like tendencies. POE oil has the ability to suspend and recirculate small, solid contaminants left from system installation or retrofit. Analysis of POE oil samples taken from actual systems have shown the oil to suspend and recirculate a high concentration of 2-20 micron sized particles, with the largest percentage between 2-10 microns. Although some particles are smaller than bearing tolerances, studies have shown bearing life can still be affected. Bearing wear depends upon the size, hardness, and concentration of particles in circulation. To effectively remove these small particles, Sporlan developed a new type of oil filter.

The **OF Series Oil Filters** are designed to be 99% efficient in removing 3 micron sized particles and yet have sufficient flow capacity at a low pressure drop. The unsurpassed filtration ability of the oil filters will assure clean POE, mineral or alkylbenzene oil is returned to the compressors. Clean oil ensures proper operation of the oil level control and minimizes compressor wear. The Sporlan OF Series Oil Filters were designed to virtually eliminate the need for oil changes resulting from suspended solid contaminants in circulation.

### Specifications

UNIT	DESCRIPTION	CONNECTIONS	FILTERING AREA cm <sup>2</sup>	OVERALL LENGTH mm	SHELL DIAMETER mm	UL RATED WORKING PRESSURE – bar
OF-303-T	Oil Filter		2097	246	76	34.5
OF-303-BP-T	Oil Filter with Bypass Feature	3/8" SAE Flare		270		
ROF-413-T*	Replaceable Oil Filter	Field Support		206	89	27.5

\*An OFE-1 Replaceable Filter Element must be purchased separately. The A-175-1 mounting bracket can be used for the ROF-413T Replaceable Oil Filter.  
Note: The OF Series Oil Filters are not suitable for use on ammonia systems

**European Product  
Information Centre**  
**Free phone: 00 800 27 27 5374**  
(from AT, BE, CH, CZ, DE, EE, ES,  
FI, FR, IE, IL, IS, IT, LU, MT, NL,  
NO, PT, SE, SK, UK)

Parker Hannifin Ltd  
**Climate and Industrial Controls Group**  
Refrigeration and Air Conditioning Europe  
Cortonwood Drive, Brampton  
South Yorkshire S73 0UF  
United Kingdom  
phone +44 (0) 1226 273400  
fax +44 (0) 1226 273401  
[www.parker.com/race](http://www.parker.com/race)

