

SUPERSEDES: March 1, 2013

EFFECTIVE: December 20, 2013

Plant ID# 9300-2868

### Cold Start Boiler Application:

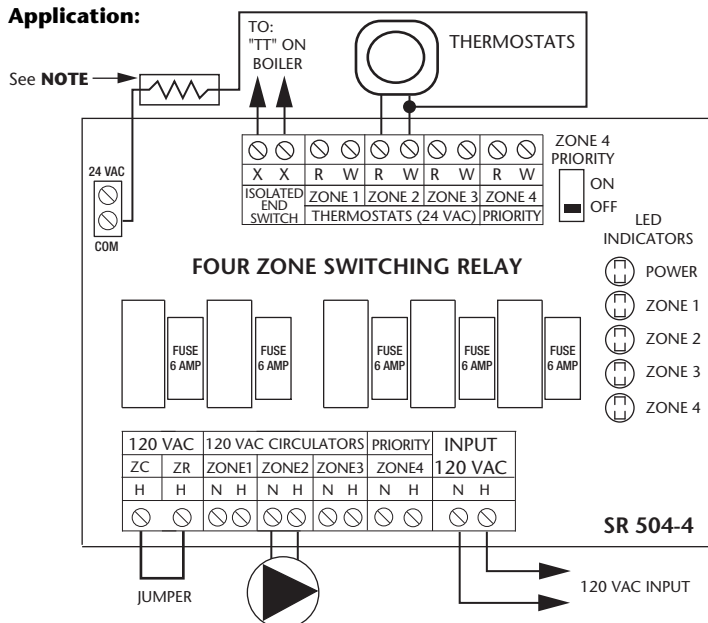

**Operation:** When any thermostat calls for heat, the appropriate circulator is energized and the isolated end switch (X and X) will start the boiler.

**Priority Operation:** When zone 4 is switched to the priority setting and is actuated, all other zones will stop operation until zone 4 is satisfied. When zone 4 is not switched to priority, all zones will operate independently.

**Priority Protection Operation:** When the priority switch is set to ON, and if the priority zone calls continuously for more than one hour, power is returned to all the other zones, allowing each zone to function independently. Once the priority zone is satisfied, the control's auto-reset is activated and the priority zone is again allowed to have priority for up to one hour starting from when it calls next.

**Jumper Placement:** The jumper should be placed between terminals ZC and ZR. Connect the isolated end switch to the aquastat control on the boiler.

**Power Input:** Connect 120 volt ac power input to terminals N and H. Neutral wire to terminal N. Hot wire to terminal H.

**NOTE:** Resistor (1K $\Omega$ , 1/2 W) may be needed between **W** and **C** terminals.

This device complies with part 15 of the FCC Rules. Operation is subject to the following two conditions: (1) This device may not cause harmful interference, and (2) this device must accept any interference received, including interference that may cause undesired operation.

**WARNING:** Wiring connections must be made in accordance with all applicable electrical codes. Use copper wire only. 120 VAC wiring must have a minimum temperature rating of 75°C. Failure to follow this instruction can result in personal injury or death and/or property damage. 12-18 gauge wire recommended for 120 VAC connections, 14-22 gauge wire for thermostat connections, and 14-22 gauge wire for 24 VAC source connections.

### Specifications:

PRODUCT NUMBER	NUMBER OF ZONES	INPUT VOLTAGE	MAXIMUM COMBINED LOAD	TYPE 1 ENCLOSURE		
				WIDTH	HEIGHT	DEPTH
SR504-4	4 with Priority	120/60/1 VAC	20 amps	10 <sup>3</sup> / <sub>4</sub> "	7"	2 <sup>3</sup> / <sub>4</sub> "

All circulator relay connections, including ZC/ZR, are rated 1/3 hp (6 FLA, 36 LRA) at 120 VAC. End switch connections are rated 24 VAC, 1 amp.  
All thermostat connections supply a 24 VAC class 2 output.



For information on Taco's Switching Relays (SR) including catalog sheet, instruction sheets, Visio stencils and our highly praised Zone Controls Wiring Guide, scan the QR code to the left or go to our website: <http://www.taco-hvac.com>.

### Tankless Coil Boiler Application: (Alternative Wiring)

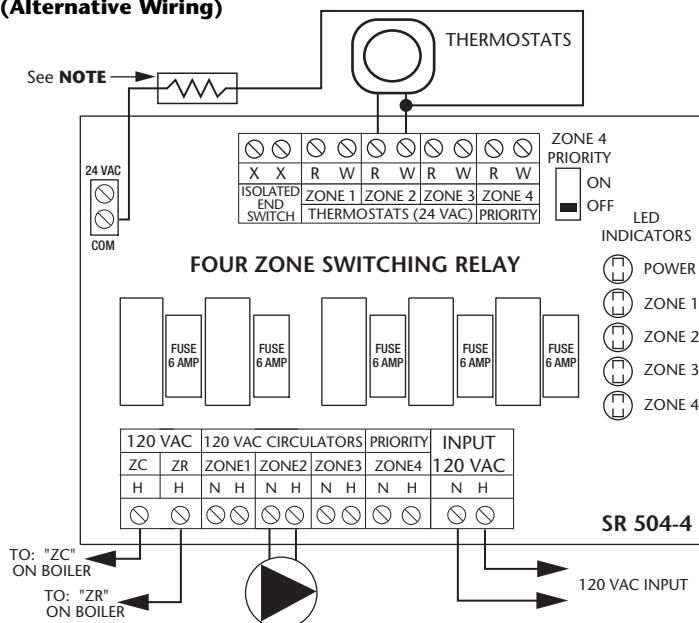

**Operation:** When any thermostat calls for heat, the boiler is given a signal to start. The appropriate circulator is energized only when the boiler temperature is above the set low limit.

**Priority Operation:** When zone 4 is switched to the priority setting and is actuated, all other zones will stop operation until zone 4 is satisfied. When zone 4 is not switched to priority, all zones will operate independently.

**Priority Protection Operation:** When the priority switch is set to ON, and if the priority zone calls continuously for more than one hour, power is returned to all the other zones, allowing each zone to function independently. Once the priority zone is satisfied, the control's auto-reset is activated and the priority zone is again allowed to have priority for up to one hour starting from when it calls next.

**Jumper Placement:** REMOVE the jumper between terminals ZC and ZR. Connect terminal ZC to ZC on the aquastat control. Connect terminal ZR to ZR on the aquastat control. Confirm polarity is consistent between boiler aquastat and switching relay.

**Power Input:** Connect 120 volt ac power input to terminals N and H. Neutral wire to terminal N. Hot wire to terminal H.

**WARNING:** When using Alternative Wiring diagram, wiring instructions must be followed so power originates from the boiler aquastat. Failure to follow these wiring instructions may result in a secondary source of power being connected to the boiler that may activate it under certain circumstances, causing injury or death.

### Troubleshooting:

- Problem:** Digital thermostats do not work correctly when connected to a switching relay.
- Solution:** Some thermostats are a "Power Stealing" type which means they are powered by the switching relay with just 2 wires (**R** & **W**). A resistor may be needed in order to have the thermostat work properly. This resistor should be placed between the **W** & **C (common)** terminals of the switching relay. If the thermostat manufacturer does not supply a resistor, a 1000 ohm 1/2 watt resistor has proven to work with most models and is readily available at electronic supply outlets (e.g. Radio Shack). If the thermostat is battery powered, then check that the batteries are fresh and installed correctly.
- Problem:** No heat in a zone or room of building.
- Solution:** LED diagnostic lights will help find a component that is not working properly. The green LED should always be on, indicating that power is connected and the solid-state fuse is good. When there is a call for heat, the red LED will come on indicating power to the zone circulator. This indicates the thermostat is working correctly. If the red LED does not come on, then check the thermostat and thermostat wiring for errors.

## Two Standard Switching Relays Connected Together (SR502 – SR506)

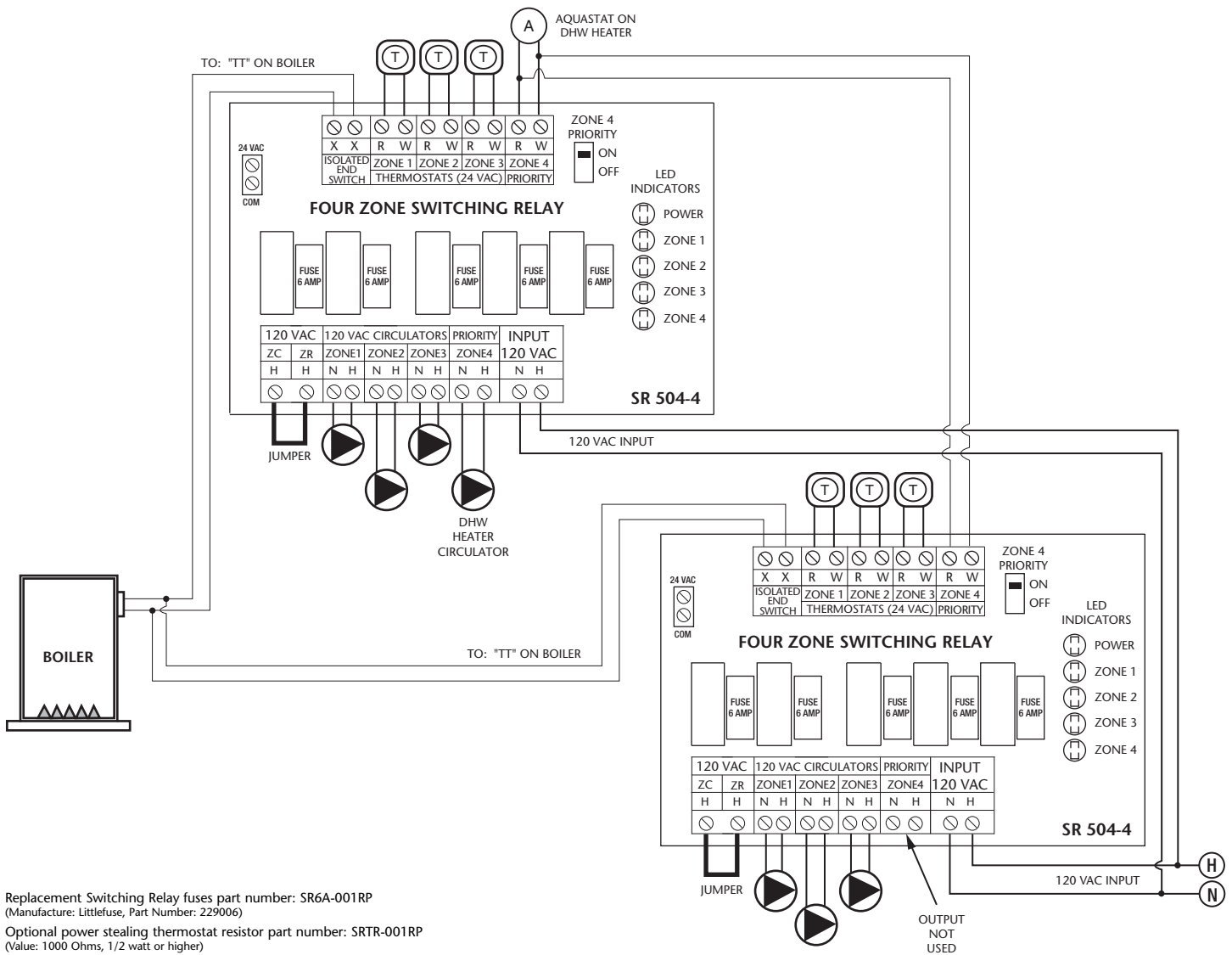

## LIMITED WARRANTY STATEMENT

Taco, Inc. will repair or replace without charge (at the company's option) any product or part which is proven defective under normal use within three (3) years from the date of start-up or three (3) years and six (6) months from date of shipment (whichever occurs first).

In order to obtain service under this warranty, it is the responsibility of the purchaser to promptly notify the local Taco stocking distributor or Taco in writing and promptly deliver the subject product or part, delivery prepaid, to the stocking distributor. For assistance on warranty returns, the purchaser may either contact the local Taco stocking distributor or Taco. If the subject product or part contains no defect as covered in this warranty, the purchaser will be billed for parts and labor charges in effect at time of factory examination and repair.

Any Taco product or part not installed or operated in conformity with Taco instructions or which

has been subject to misuse, misapplication, the addition of petroleum-based fluids or certain chemical additives to the systems, or other abuse, will not be covered by this warranty.

If in doubt as to whether a particular substance is suitable for use with a Taco product or part, or for any application restrictions, consult the applicable Taco instruction sheets or contact Taco at [401-942-8000].

Taco reserves the right to provide replacement products and parts which are substantially similar in design and functionally equivalent to the defective product or part. Taco reserves the right to make changes in details of design, construction, or arrangement of materials of its products without notification.

TACO OFFERS THIS WARRANTY IN LIEU OF ALL OTHER EXPRESS WARRANTIES. ANY WARRANTY IMPLIED BY LAW INCLUDING WARRANTIES OF MERCHANTABILITY OR FIT-

NESS IS IN EFFECT ONLY FOR THE DURATION OF THE EXPRESS WARRANTY SET FORTH IN THE FIRST PARAGRAPH ABOVE.

THE ABOVE WARRANTIES ARE IN LIEU OF ALL OTHER WARRANTIES, EXPRESS OR STATUTORY, OR ANY OTHER WARRANTY OBLIGATION ON THE PART OF TACO.

TACO WILL NOT BE LIABLE FOR ANY SPECIAL, INCIDENTAL, INDIRECT OR CONSEQUENTIAL DAMAGES RESULTING FROM THE USE OF ITS PRODUCTS OR ANY INCIDENTAL COSTS OF REMOVING OR REPLACING DEFECTIVE PRODUCTS.

This warranty gives the purchaser specific rights, and the purchaser may have other rights which vary from state to state. Some states do not allow limitations on how long an implied warranty lasts or on the exclusion of incidental or consequential damages, so these limitations or exclusions may not apply to you.

**Taco Comfort Solutions™** A Taco Group Company

Taco, Inc., 1160 Cranston Street, Cranston, RI 02920 | Tel: (401) 942-8000 | FAX: (401) 942-2360

Taco (Canada), Ltd., 8450 Lawson Road, Suite #3, Milton, Ontario L9T 0J8 | Tel: (905) 564-9422 | FAX: (905) 564-9436

Visit our web site: [www.TacoComfort.com](http://www.TacoComfort.com) | Printed in USA | ©2015 Taco, Inc.

