

**MODELS:****VH30100** 30-100 CFM HRV**VE30100** 30-100 CFM ERV**Features**

- Three operating modes (Intermittent, Continuous and High)
- 100% variable speed
- Quick-connect duct collar system
- Proportional defrost sequence
- Single-person mounting system
- Dual permanently lubricated PSC motors
- Integral balancing taps in duct collars
- Wall-mounting bracket included

VH30100 COMPACT HEAT RECOVERY VENTILATOR VE30100 COMPACT ENERGY RECOVERY VENTILATOR

Installation and Operation Manual



IMPORTANT: READ AND SAVE THESE INSTRUCTIONS. THIS GUIDE TO BE LEFT WITH EQUIPMENT OWNER.



TABLE OF CONTENTS

SAFETY CONSIDERATIONS 3

VENTILATION REQUIREMENTS 4

Determine Your Ventilation Needs 4

FITTING EQUIVALENT LENGTHS 5

TYPES OF INSTALLATIONS 6

Independent System installation 6

Exhaust at the Source and Supply in the Return 6

Exhaust and Supply in the Return 7

Installation Kit 7

Finding a Suitable Installation Area HRV or ERV 7

INSTALLATION 8

Installation of the HRV / ERV 8

Insulated Flex from Unit to Outside Wall 8

Condensation Drain Line 9

Supplying Power to the HRV/ERV 9

Installing Ventilation Hoods 10

MATRIX™ Ventilation Hoods 10

CONTROLS WIRING 11

Controls Connection 11

Wiring Diagrams for Furnace interlock systems 11

Alternate Forced-air Interlocking Wiring 12

SEQUENCE OF OPERATIONS 13

Sequence of Operations for Ventilator and Connected Wall Controls and Timer 13

VENTILATION CONTROL 13

BALANCING THE UNIT 14

TROUBLESHOOTING 16

MAINTENANCE 17

WARRANTY 18

CAUTION!

Do not install in a cooking area or connect directly to any appliance. Turn off all integral disconnects before servicing.

Notice: Prior to installing, serious consideration must be taken to ensure this ventilation system will operate properly if integrated with any other type of mechanical system such as a forced air system or an air handling unit. To ensure proper operation and compatibilities of both systems, the airflows of the Heat Recovery Ventilator (HRV) or Energy Recovery Ventilator (ERV) must be balanced by the installer, by following the procedures found in this manual.

The way in which your HRV/ERV is installed may make a significant difference to the electrical energy consumed when operating. To minimize the electricity use of the HRV/ERV, a stand-alone fully ducted installation is recommended. If you choose a simplified installation that operates your furnace or air handler for room-to-room ventilation, electrical energy consumption and operating cost will be greatly reduced if the blower of the system's furnace or air handler has an electronically commutated (ECM) motor.

Limitations: The product is for residential applications only and must be installed in accordance with all national and local regulations, building and safety codes.

*INSTALLATION DATE (MM/DD/YYYY) (/ /)

MODEL#: _____

SERIAL #: _____

*Ask Dealer to provide this information.

Proprietary Notice

This document and the information disclosed herein are proprietary data of Daikin North America LLC. Neither this document nor the information contained herein shall be reproduced, used, or disclosed to others without the written authorization of Daikin North America LLC except to the extent required for installation or maintenance of recipient's equipment.

Liability Notice

Daikin North America LLC does not accept any liability for installations of ventilation equipment installed by unqualified personnel or the use of parts/components/equipment that are not authorized or approved by Daikin.



Our continuing commitment to quality products may mean a change in specifications without notice.

© 2015 DAIKIN NORTH AMERICA LLC

All rights reserved.
Houston, Texas • USA
www.cleancomfort.com
1-888-724-5211



SAFETY CONSIDERATIONS

WARNING!

- To reduce the risk of injury, disconnect power to the ventilation system while performing service on the unit. There are impeller wheels turning at a very high speed that must fully stop rotating prior to accessing the inside of the unit.
- To reduce the risk of electric shock or fire, do not perform any service to the HRV system other than as stated in the operating manual instructions.
- To reduce the risk of electric shock, this ventilation system comes equipped with a 3-prong plug. This plug will fit in a polarized 120VAC outlet in only one orientation. Do not modify the power plug in any way; if modified, there is risk of electric shock or fire.
- Do not use the ventilation system for removal of flammable fumes, gases or connect directly to any appliances.
- Do not modify, repair or disassemble this system. These tasks are to be performed by authorized serviced personnel only. Fire, electrical shock and/or bodily injury may result if these warnings are not followed.
- Always assess the operation of the ventilation system with regard to how it may interact with vented combustion equipment (e.g. gas furnace, oil furnace, combustion appliances)

CAUTION!

- Do not use this ventilation system for outdoor applications. The electrical components in this ventilation system are only certified for indoor use.
- Do not pull or twist the ventilation system's power cord when disconnecting it from the power receptacle. Grasp the plug firmly, not the cord.
- Do not obstruct or cover the air intake or air outlet of the ventilation system.
- Do not use for ventilation of areas with swimming pools or spas.



VENTILATION REQUIREMENTS

Determine Your Ventilation Needs

Good indoor air quality is based in part on the capacity of the home's ventilation system.

The two most common methods for determining the ventilation needs of a home are the Room Count Calculation method and the Air Change Per Hour method. Both methods calculate an approximate ventilation rate (in CFM or L/s). Their calculation methods are described on this page.

A. Room Count Calculation Method

LIVING SPACE	NUMBER OF ROOMS	CFM (L/S)		CFM REQUIRED	
Master Bedroom	-----	x 20 cfm (10 L/s)	=	-----	
Basement	-----	x 20 cfm (10 L/s)	=	-----	
Single Bedroom	-----	x 10 cfm (5 L/s)	=	-----	
Living Room	-----	x 10 cfm (5 L/s)	=	-----	
Dining Room	-----	x 10 cfm (5 L/s)	=	-----	
Family Room	-----	x 10 cfm (5 L/s)	=	-----	
Recreation Room	-----	x 10 cfm (5 L/s)	=	-----	
Other	-----	x 10 cfm (5 L/s)	=	-----	
<hr/>					
Kitchen	-----	x 10 cfm (5 L/s)	=	-----	
Bathroom	-----	x 10 cfm (5 L/s)	=	-----	
Laundry Room	-----	x 10 cfm (5 L/s)	=	-----	
Utility Room	-----	x 10 cfm (5 L/s)	=	-----	
<hr/>					
TOTAL ventilation requirement (add last column)				=	-----

1 CFM = 0.47189 L/s
 1 L/s = 3.6 m3/hr

B. Air Change Per Hour Calculation Method

TOTAL volume of the house (in cubic feet) X 0.35 air changes/hour = CUBIC FT/HR

Take total CUBIC FT/HR and divide by 60 to get CFM

Example: A 25'x 40' house with basement:

25' X 40' = 1,000 sq. ft.

1,000 sq. ft. x 8' room height x 2 storeys

(1st floor + basement) = 16,000 cu. ft.

16,000 cu. ft. x 0.35 ACH = 5,600 cu. ft.

5,600 cu. ft. / 60 = 93.3 CFM

93.3 CFM is your ventilation requirement



FITTING EQUIVALENT LENGTHS

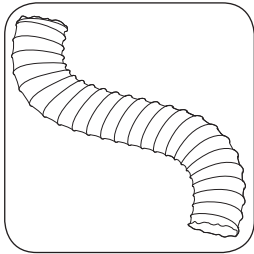

- Flex pipe equivalent length is smooth pipe x2
- Flex fitting equivalent length is smooth fitting x2

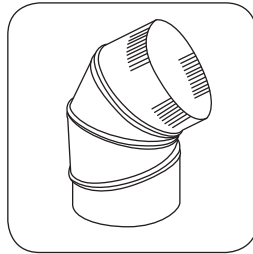

- 45° perimeter pipe elbow equivalent length = 5 ft. (1.52 m)

NOTE: Where flex duct is used to make 45° elbow equivalent length = 10 ft. (3.0 m)

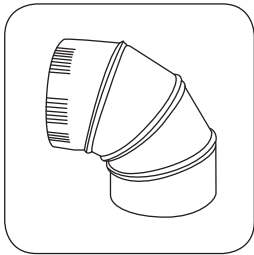

- 90° perimeter pipe elbow equivalent length = 10 ft. (3.0 m)
- NOTE:** Where flex duct is used to make 90° elbow equivalent length = 20 ft. (6.1 m)

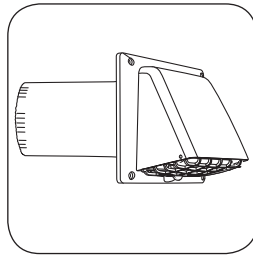

- Round wall cap spring damper or screen equivalent lengths = 60 ft. (18.29 m)

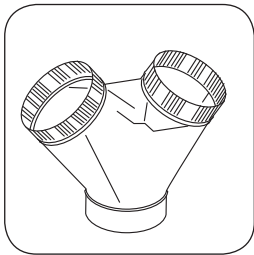

- Y-equal sides equivalent length = 10 ft. (3.0 m)

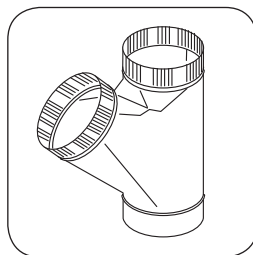

- Y-Side branch equivalent length = 35 ft. (10.7 m)

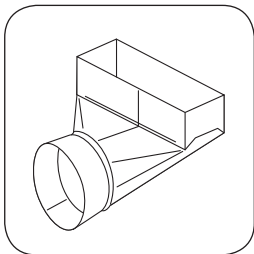

- Angle boot equivalent length = 30 ft. (9.14 m)

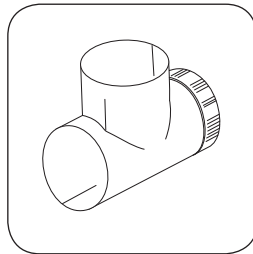

- Tee take-off equivalent length = 50 ft. (15.24 m)

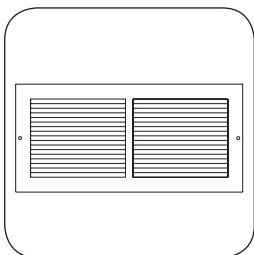

- Wall grille 50% free area equivalent length = 15 ft. (4.6 m)

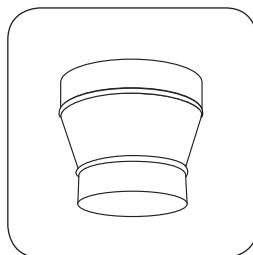

- Increaser/Reducer equivalent length = 8 ft. (2.43 m)

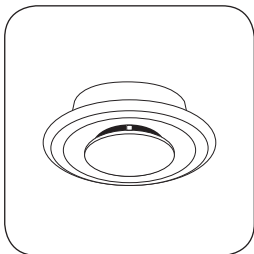

- Round plastic diffuser equivalent length = 100 ft. (30.5 m)

NOTE: Maximum airflow assumes diffuser is in full open position.



TYPES OF INSTALLATIONS

Independent System Installation

From an Indoor Air Quality standpoint, this is the preferred method of installing a ventilation system in a home. This installation uses a dedicated duct system for both the supply of fresh air and exhausting of stale air accumulated in the home.

With an Independent System installation, fresh air is supplied to all bedrooms and living areas and stale air is exhausted from the bathroom, kitchen and laundry room. See Figure 1.

Important: For correct performance of your HRV or ERV, the installation of a 6" round galvanized backdraft damper is required on the ductwork supplying fresh air to the home.

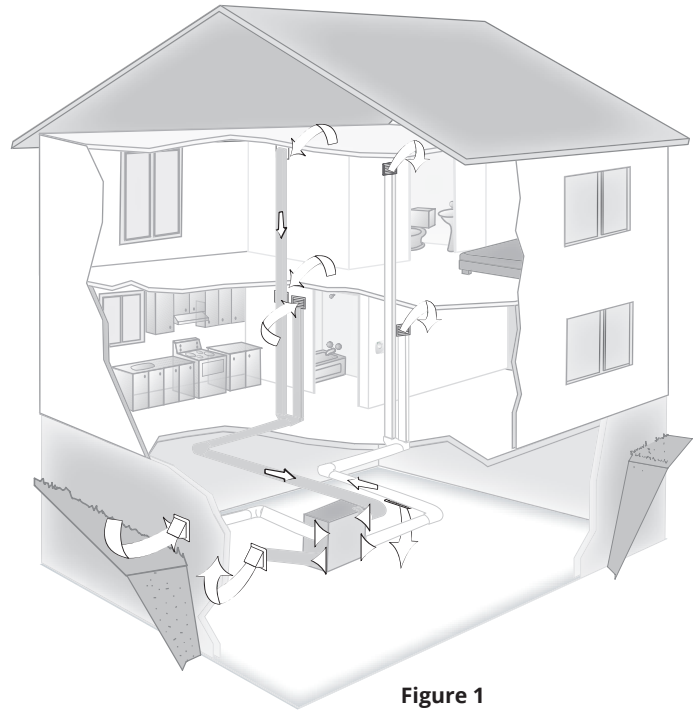

Figure 1

Exhaust at the Source and Supply in the Return

This application uses a dedicated duct system for exhausting the stale air from the home. The fresh air is routed to the return air duct and is distributed through the home by the existing supply air ductwork of the forced-air system. See Figure 2.

Make sure when using this installation that your fresh air duct connection to the forced air system return air duct is not less than 10ft (3 m) upstream of the return plenum connection to the forced-air system. Check with your local building codes or the manufacturer of the forced-air system. The HRV and forced-air system must be set to operate in continuous mode to achieve maximum comfort and to avoid cross-contamination.

Note to Installer: Dwellings with multiple forced-air systems require one HRV/ERV per system.

Ensure the unit runs in conjunction with the forced-air system. Refer to wiring diagram for furnace interlock instructions.

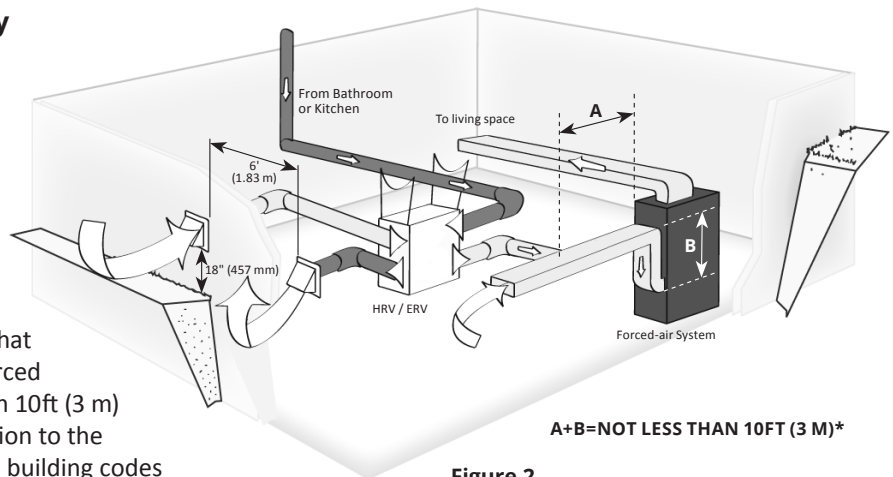

Figure 2

* For minimum distance between return and forced-air system, check with your local building codes or the manufacturer of the forced-air system.

Important: The duct bringing outdoor air to the return air plenum must be equipped with a manual damper to balance the outdoor airflow.

Important: For optimal performance of your HRV or ERV, the installation of an optional 6" round galvanized backdraft damper is required on the fresh-air-to-home duct work. When performing duct connections, always use approved tools and materials. Also use steel duct connections for this type of installation.



TYPES OF INSTALLATIONS

Exhaust and Supply in the Return

When using this installation, make sure that there is minimum of 3 feet (0.9m) between the fresh air and exhaust air connections of the HRV/ERV in the return air duct. See Figure 3. Make sure when using this installation that the fresh air duct connection to the forced-air system return air duct is not less than 10ft (3 m) upstream of the return plenum connection to the forced air system. Check with your local code or the forced air system's manufacturer. The HRV and forced-air system must be set to operate in continuous mode to achieve maximum comfort and to avoid cross-contamination.

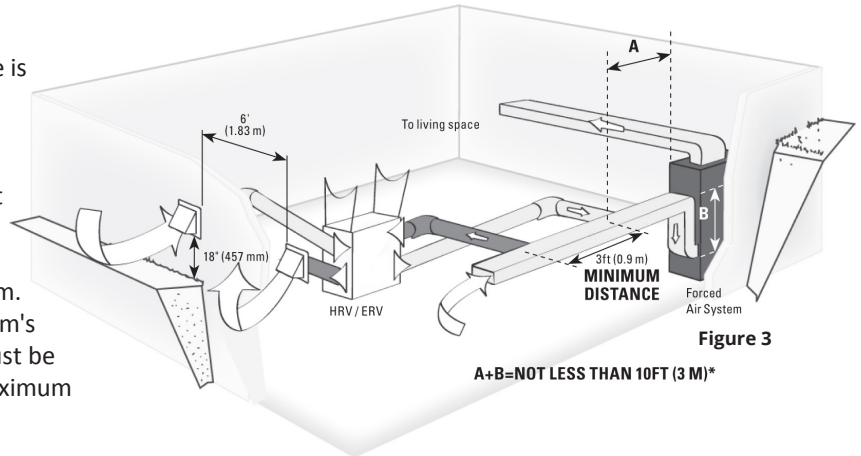

Figure 3

Note to installer: Dwellings with multiple forced-air systems require one HRV/ERV per system.

Ensure the unit runs in conjunction with forced-air system. Refer to wiring diagram for furnace interlock instructions.

* For minimum distance between return and forced-air system, check with your local building codes or the manufacturer of the forced-air system.

Important: The duct bringing outdoor air to the return air plenum must be equipped with a manual damper to balance the outdoor airflow.

Important: Building and combustion appliance installation codes do not allow return air grilles or openings such as "breather tee" or indirect connections in an enclosed room that is susceptible to spillage of combustion appliances.

Simplified Connection

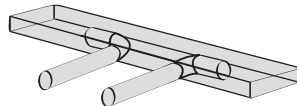

Indirect Connection

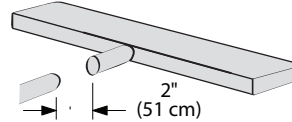

Breather Tee

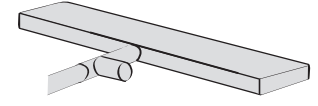

Important: For optimal performance of your HRV or ERV, the installation of an optional 6" round galvanized backdraft damper is required on the fresh-air-to-home duct work. When

performing duct connections, always use approved tools and materials. Also use steel duct connections for this type of installation.

Installation Kit

Installation Kit Includes:

- 4 Collars
- 4 Caps, Pressure Taps
- 1 Condensation Drain Line
- 1 Drain Adapter with Nut
- 12 screws (#10 x 11/4")
- 2 screws (#8 x 3/8")
- 120VAC power cord
- Wall-Mounting Bracket



Figure 4

Tip to Installer: Removing the core unit will facilitate your installation.

Finding a Suitable Installation Location

The HRV/ERV unit should be installed in a mechanical room or as close to an outside wall as possible. This would ensure a short run of insulated flexible duct.

The HRV/ERV unit must always be installed in an area where the air is tempered to avoid freezing of the condensate line. The contractor should install the unit in an area that is accessible to allow the homeowner easy access for performing maintenance.

It is very important to install an electric receptacle (120VAC) near the HRV/ERV. A separate circuit breaker is also recommended. Installing the HRV/ERV close to a drain for the condensate would avoid the need for a condensate pump.



INSTALLATION

Installation of the HRV/ERV

IMPORTANT Minimum installation requirements:

- a) Minimum two 2"x 4" (50.8 mm x 101.6 mm) wood wall studs and minimum 3/8" (9.5 mm) thick drywall is required to secure the HRV/ERV wall bracket.
- b) Support for weight of 80 lbs, which includes HRV/ERV, duct connections and accessories. Proper installation requires that the unit be secured to the wall. If there are no wall studs available, secure a sheet of 3/4" plywood to wall then fasten wall mounting bracket to plywood.

Tip to installer: If the unit is not level, improper drainage will occur and could lead to moisture and leakage problems.

It is recommended that approximately 16 inches of flexible duct be installed between the HRV or ERV and your rigid duct. The flexible duct is connected to the HRV or ERV in the same way as the insulated flex.



Figure 5 Installation of the wall bracket. Secure with two #10 x 1 1/4" screws.



Figure 6 Hang HRV/ERV on the wall-mounting bracket.



Figure 7 Before completing the installation, make sure that the HRV/ERV is level.



Figure 8 Secure HRV/ERV to wall-mounting bracket with the two, #8 x 3/8" screws.

NOTE: Clean Comfort Ventilators (HRV/ERV) that use a fan shut down defrost sequence for frost protection are NOT equipped with a motorized outdoor air damper.

Special consideration is required when one of the following types of installations is chosen:

- a) Exhaust at the source and supply in the return air duct, or
- b) Exhaust and supply in the return air duct

The HRV/ERV must operate in the continuous ventilation mode to avoid cold, unconditioned air being introduced through the unit and directly into the furnace during heating season. However if the homeowner chooses to run the unit in Intermittent ("INTER") mode or turn it "OFF", cold supply air will be drawn in through the HRV/ERV when the system's blower fan is operating e.g. during a heating cycle. We recommend installing a motorized damper between the HRV/ERV supply air connection and the furnace's return air duct that will automatically close when the HRV/ERV is not operating. You may also consider the installation of a backdraft damper on the ventilator's exhaust air connection to prevent cold air infiltration.

Alternatively, installing a ventilator that employs a recirculating defrost sequence and is equipped with an integrated motorized outdoor air damper, such as the VH30120R or VH30160R, would avoid the problem described above.

Insulated Flex from Unit to Outside Wall

Tip to installer: To ensure a better installation and to avoid an undesired bend in the duct, align the flexible duct with the collar before securing over the four hooks on the inner surfaces of the collar.

All ducting to and from the HRV/ERV must be adequately insulated to minimize heat loss and gain. All tapes, mastics, and nonmetallic clamps used for field installation of flexible ducts shall be listed and labeled to Standard UL 181B - Closure Systems for Use With Flexible Air Ducts and Air Connectors.

Once insulated flex is attached to the collar, slide collar into the keeper section and attach collar to the unit with four, #10 x 5/8" screws supplied in installation kit to ensure a proper seal. See Figures 9-13 on following page.



INSTALLATION



Figure 9 Insert flexible duct over the hooks and seal with a tie wrap.



Figure 10 Insert insulation inside the double collar.



Figure 11 Finish by taping the vapor barrier to the collar to ensure proper seal.



Figure 12 Slide collar into the keeper section of the unit.



Figure 13 Fix and secure the collars to the HRV/ERV with the #10 x 1 1/4" screws, supplied in kit.

CAUTION! Always consult your national and local regulations, building and safety codes.

WARNING!

Always secure the 5" detachable collars with the screws provided. If this is not done, condensate may accumulate inside the ventilator causing damage.

Condensation Drain Line

Insert the threaded drain adapter through the bottom of the HRV/ERV and hand tighten the plastic nut supplied with the installation kit. Use a wrench to tighten the nut another half turn to ensure a complete seal.

Install the condensate line (included in installation kit) by pushing the clear plastic tubing over the drain adapter. Make a condensate trap by looping the clear plastic tubing. The function of this condensate trap is to prevent unpleasant odors from entering the HRV/ERV. See Figures 14-15.

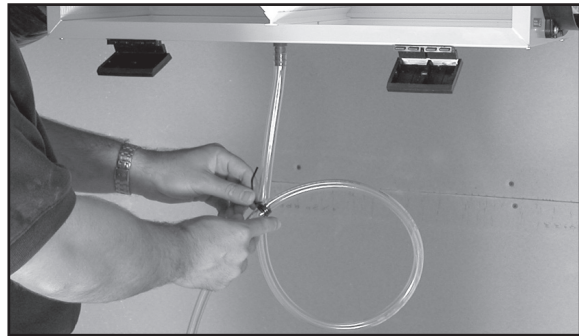

Figure 14 Create a trap by forming a loop in the condensate tubing. Ensure this trap will not be exposed to temperatures where the condensate can freeze.



Figure 15 Use a condensate pump if you don't have access to a drain.

Supplying Power to the HRV/ERV

IMPORTANT: Only qualified service technicians should install, repair, or service this HRV/ERV.

NOTE: If the LED light on the unit's control is lit (green), but the unit's motors do not energize and the controls do not operate, this indicates that the polarization in the main power supply outlet is inverted. Correct polarity of supplied power before continuing with the installation.

Daikin recommends that the unit be connected to a dedicated 120VAC receptacle; use of an extension cord to power the unit is not recommended. If no receptacle is available near the unit, have a licensed electrician install one.

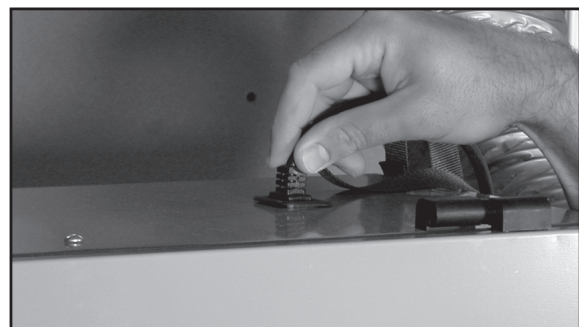

Figure 16 Insert the power cord on top of the unit. Press firmly to make sure the power cord is secure.



INSTALLATION

Installing Ventilation Hoods for Fresh Air and Exhaust

Install the outside ventilation hoods at least 18 inches (0.5 m) above ground level or above the anticipated snow level, and we recommend with at least 6 ft (1.8 m) between the fresh air intake and the exhaust.

Always properly seal the supply and exhaust hoods to the exterior of the thermal envelope of the building with caulk or other similar material to inhibit air leakage.

Note: Fresh air intake hoods shall be located to avoid combustion sources or sources of pollutants such as:

- Exhaust air vents from this HRV/ERV, a clothes dryer or combustion appliances
- Driveways (auto exhaust)
- Gas meters, oil fill pipes
- Garbage containers
- Attics or crawl spaces
- Under deck or other areas of questionable air quality

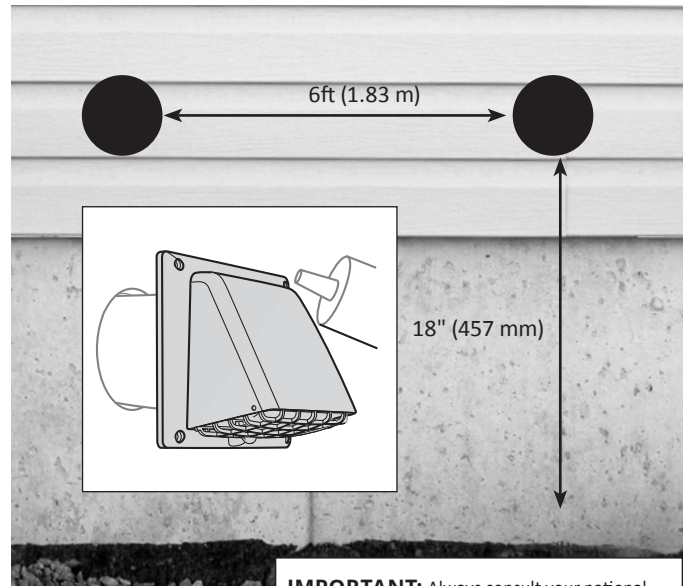

Figure 17 Locating Outside Hoods

IMPORTANT: Always consult your national and local regulations, building and safety codes.

Matrix™ High-Performance Ventilation Hood Installation

Important: Install ventilation hood a minimum of 18" (457 mm) above ground level or the anticipated snow level.

Do not install under a deck, enclose porch, patio, garage, crawl space or attic.

⚠ WARNING!

Ensure the ventilation hood is installed with a minimum clearance of 6 ft (1.83 m) away from the exhaust vents of a combustion source or a source of pollutants such as a gas furnace, dryer, gas boiler, range hood, barbecue, garbage bin, driveway or garage..

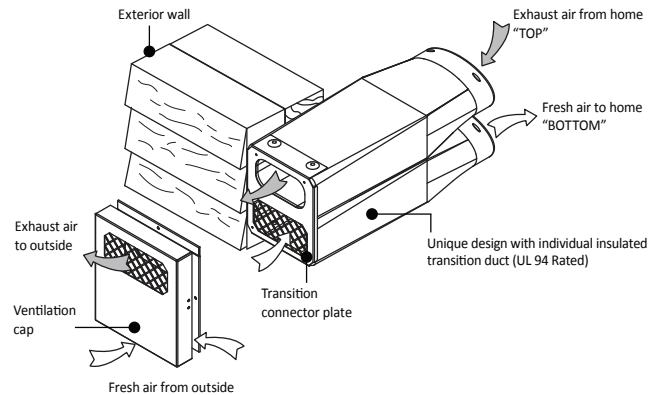

Airflow Performance Data

Limitations: The Matrix ventilation hood is for residential applications of 110 CFM or less ONLY.

It must be installed in accordance with all current national and local regulation building and safety codes.

Airflow

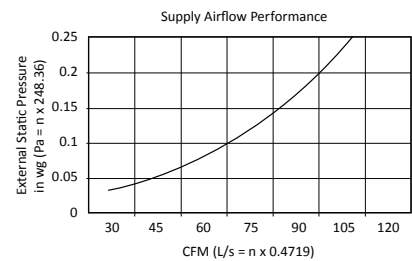
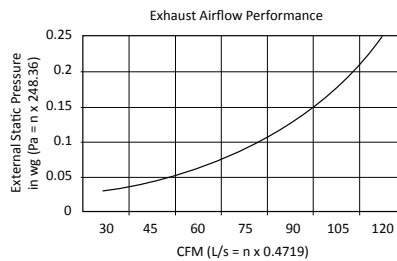

CONTROLS / WIRING



Controls Connection

Wiring connections are shown for the Clean Comfort VHP Series wall controls and timer. See Sequence of Operations table for description of operation of these wall controls and timer with the ventilator.

VHP-RD1 (2 wires)

This control will operate the ventilator when the relative humidity level measured at the control is higher than the setting on the control.

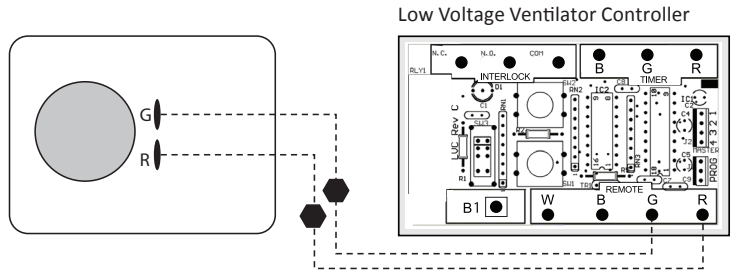

VHP-RD3P (4 wires)

This control will operate the ventilator when the relative humidity level measured at the control is higher than the setting on the control. It can also override the control on the ventilator by reducing maximum fan speed by 30% on CONT setting and 15% on High (Override) speed.

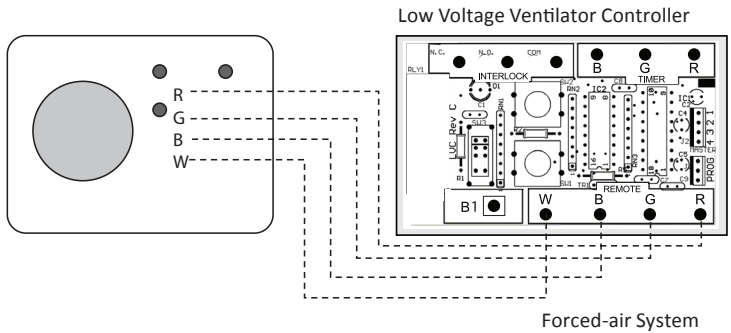

VHP-T3 TIMER (3 wires)

This control will operate the ventilator on high speed for the length of time (20, 40 or 60 minutes) selected by the user.

CAUTION!

Minimum wire requirement is LVT18 CSA/UL 4 strand to ensure proper connection.

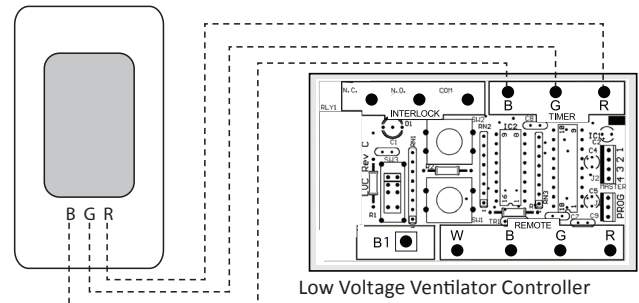

Wiring Diagrams for Furnace Interlock Systems

Standard Forced-air Interlocking Wiring

A relay is normally used when tying a ventilation system into the forced-air distribution system. The low voltage ventilator control on the ventilator is equipped with an internal relay that will activate the forced-air system's ventilator when there is a demand from the HRV /ERV.

This ventilator control will activate the INTERLOCK relay during the following modes: Continuous, Override, Recirculation and Defrost. See wiring diagram at right.

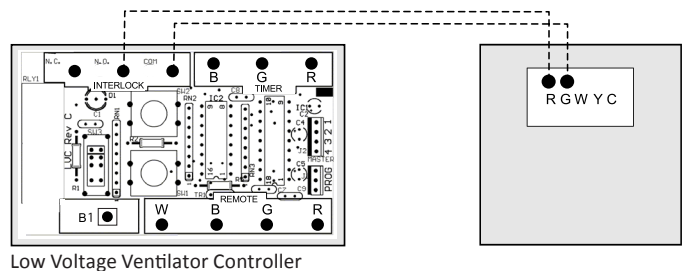

Legend: ----- Field Installed Low Voltage

Figure 18 Standard forced-air wiring diagram



VENTILATION REQUIREMENTS

Alternate Forced-Air Interlock Wiring

Some thermostats will activate the cooling system when used with the Standard Forced-Air Interlock Wiring.

If your thermostat operates this way, you must use the Alternate Forced-Air Wiring shown at right.

Locating the Wiring Diagram

Note to installer: Wiring diagrams for the Clean Comfort ventilators are placed on the inside back cover of the exhaust motor bracket of each unit.

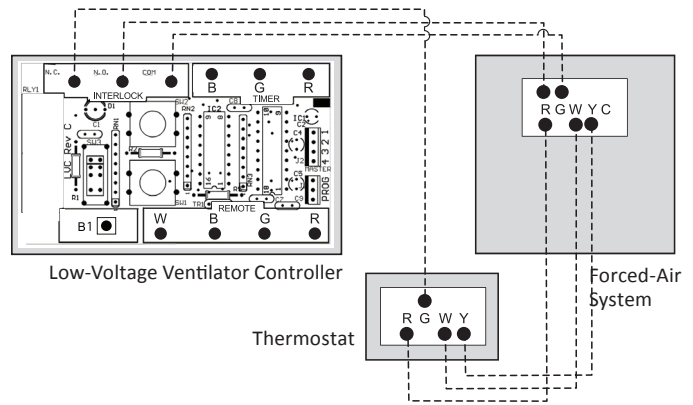

Legend: ----- Field-Installed Low Voltage

Figure 19 Alternate forced-air wiring diagram

* Before wiring the ventilator to a forced-air system, always refer to system's manual or manufacturer.

CAUTION!
Thermostats that control A/C system must use the Alternate Interlock Wiring Diagram.

WARNING!
Always disconnect power to the unit prior to making any electrical connections. Failure to disconnect the power could result in electrical shock or can damage the electronic boards, wall controls and/or unit.

CAUTION!
Minimum wire requirements is LVT18 CSA/UL 4 strand to ensure proper connection.



Sequence of Operations for Ventilator and Connected Wall Controls and Timer

There is a low voltage ventilator control mounted on the HRV/ERV to operate the ventilator in Intermittent (INTER) or Continuous (CONT) operation. When a VHP-RD3P wall control is connected to the ventilator, it can override the setting on the ventilator as described in the table below.

In addition, the VHP-RD3P has the ability to operate the ventilator at a reduced speed by setting the RANGE selector on the VHP-RD3P to the REDUCED position. In this position, the ventilator will run at 15% slower fan speed in CONT mode and 30% slower in Override (High) speed when responding to a high humidity signal from the VHP-RD1 or VHP-RD3P wall control or when the VHP-T3 timer is activated.

Ventilator Control Setting	VHP-RD3P Control Setting	Action
INTER	INTERM	Ventilator runs intermittently (unit is dormant) but goes to high speed when %RH is above set point on the wall control, or if a VHP-T3 timer is activated.
INTER	CONT	Ventilator runs continuously on set speed at ventilator or set speed on the range setting from the wall control. It will go to HIGH speed when %RH is above set point on the wall control or if a VHP-T3 timer is activated.
CONT	INTERM	Ventilator runs intermittently (unit is dormant) but goes to high speed when %RH is above set point on the wall control or if a VHP-T3 timer is activated.
CONT	CONT	Ventilator runs continuously on set speed at ventilator or set speed on the range setting on the wall control but goes to HIGH speed when %RH is above set point on the wall control or if a VHP-T3 timer is activated.
INTER or CONT	OFF	Ventilator does not run even if the Ventilator is set to INTER or CONT. Ventilator will not go to high speed even if the %RH is above set point on the wall control or if a VHP-T3 Timer is activated.
OFF	INTERM or CONT	Ventilator does not run, even if the wall control is set to INTER or CONT mode. The Ventilator will not go to high speed even if the %RH is above set point on the wall control or if a VHP-T3 timer is activated.
INTER or CONT	RH sensor dial set to OFF	Ventilator does not run based on RH measured at the wall control (sensor is disabled). Otherwise the Ventilator and the wall control operates as described above and will go to high speed if a VHP-T3 timer is activated.

Ventilation Control

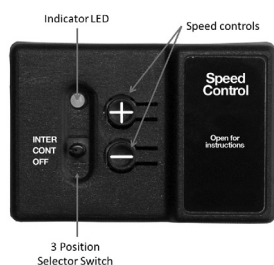

The low voltage ventilator control mounted on the HRV/ERV has a three-position selector switch and buttons (marked “+” and “-”) to adjust fan speed. The color of the LED light located above the selector switch indicates the operating mode of the control as follows:

- LED is GREEN = Control is in Run mode (normal operation)
- LED is YELLOW = Control is in Balancing mode

RUN Mode

When the LED is green, the control is in RUN mode and the selector switch is used to set the ventilator’s Operating Mode. The options are:

- **INTER (Intermittent):** With the selector switch in the INTER position, the unit runs only on a call for ventilation from an external wall control or timer. It will then run on high speed until the call is satisfied.
- **CONT (Continuous):** With the selector switch in the CONT position, the unit runs continuously (low speed) until there’s a remote call for ventilation (override) from an external control.
- **OFF:** When the selector switch is in the OFF position, the ventilator will not operate even if there’s a remote call for ventilation from an external control.



SEQUENCE OF OPERATIONS

(+) and (-) buttons: These buttons are used for adjusting both the high and CONT fan speed settings when the control is in RUN mode.

BALANCING Mode

When the control is set to Balancing mode, the LED indicator turns yellow and the selector switch is used for setting the high speed of the fans for balancing purposes (Supply (fresh) air, Exhaust air, and Both). The options are:

- **INTER (Intermittent):** With the selector switch in this position, the speed of the exhaust air fan can be set
- **CONT (Continuous):** With the selector switch in this position, the speed of BOTH the exhaust and supply air fans can be set
- **OFF:** With the selector switch in this position, the speed of the supply air fan can be set.

(+) and (-) buttons: These buttons are used for adjusting the fan speed of either or both of the supply and exhaust fan motors, depending on the fan motor selected by the position of the selector switch. The + button increases the speed of the fan being adjusted and the (-) button decreases the speed.

NOTES:

1. Continuous low speed is 50% of the fan speed selected for HIGH speed.
2. When the LED stops flashing, the ventilator is at its maximum speed.

Procedure for Setting High (Override) Airflow Rate and Balancing the Ventilator

To balance the ventilator, you will need to independently adjust the flow rate in both the fresh air (supply) duct as well as the stale air (exhaust) duct. You will need an airflow measuring device such as a pitot tube or a Magnehelic gauge.

NOTE: Turn the HVAC equipment fan ON while performing these balancing steps

1. Once the total CFM needed is determined (see Ventilation Requirements section), you can start balancing the HRV/ERV.
2. Set the three-position selector switch on the ventilator control to either the INTER or CONT position.
3. Press and hold both the (+) and (-) buttons simultaneously for 5 seconds until the LED light turns yellow, indicating the unit is now in Balancing mode.

4. When in Balancing mode, the selector switch becomes the motor selector switch. The switch position selects which fan motors will be adjusted during balancing.

Selector Switch Position	Fan Motor Being Adjusted
INTER	Right (Exhaust)
CONT	Both Motors
OFF	Left Motor (Fresh Air Supply)

5. Adjust the airflow rate in the fresh air duct by setting the selector switch to the OFF position.
6. Connect the airflow measuring device to the integral balancing taps on the ventilator's collars.

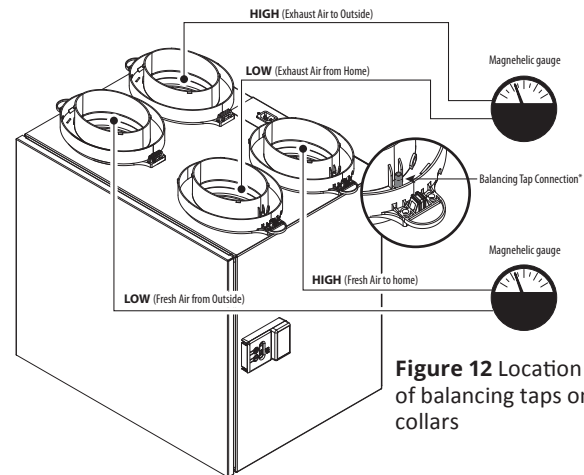

Figure 12 Location of balancing taps on collars



Magnehelic Gauge with Airflow Grid

7. Press the (+) and (-) buttons on the ventilator control to increase or decrease the fan motor speed to produce the desired airflow in the duct being measured.

Note: When the LED stops flashing, the ventilator is at its maximum speed.

BALANCING THE UNIT



8. Perform the same operation on the stale air side by selecting the INTER position on the selector switch. Adjust the airflow rate in the stale air duct to be the same as the airflow rate in the fresh air duct, so the airflow entering and leaving the building is balanced.
9. If necessary, the selector switch can be set to the CONT position, which will adjust the speed of both fan motors at the same time.
10. Once this is done, you have set and locked the high speed on your ventilator and balanced the fresh and stale airflow rates.
11. To exit Balancing mode, press the (+) and (-) buttons at the same time until the LED turns green, indicating that the control has returned to Run mode.

Procedure for Setting Low (Continuous) Ventilation Rate

When the unit is in Run mode, the continuous airflow rate can then be set by using the (+) and (-) buttons and reading the CFM using the airflow measuring device.

1. When the unit is in Run mode, the continuous airflow rate can then be set by using the (+) and (-) buttons and reading the CFM using the airflow measuring device.
2. When the selector switch is set to the CONT position, the ventilator runs at the low (continuous) speed until there's a remote call for ventilation (override) from an external control such as the VHP Series of controls.

Balancing Reset

Balancing of the ventilator is locked upon exiting Balancing Mode and can only be changed with a reset of the control.

To Reset Control

1. Press the (+) and (-) buttons simultaneously for 10 seconds. After 5 seconds, the LED will turn yellow and after 10 seconds, it will turn green

2. Release both buttons
3. Unit has now been reset and is ready for re-balancing, if necessary

Testing the Ventilator to Confirm Operation

1. Apply power to the ventilator. Set the selector switch to the CONT position. Verify that the unit turns on and operates at continuous speed
2. Turn the wall control to minimum humidity setting to create a call for ventilation. Verify that the ventilator turns on and operates at high speed. Return wall control to normal humidity setting.
3. Repeat for timer control, if one is installed
4. Return the selector switch to the desired position (INTER or CONT) and the wall control to the desired settings
5. Inspect the ductwork to verify there are no bends, kinks or obstructions to airflow. Correct as needed.

***Important:** Once balancing is complete, ensure all four pressure taps are sealed with the rubber caps. Pressure taps are supplied in the installation kit.

Balancing chart

This balancing chart is based on a Delta P (DP) reading from the airflow measuring device. A copy of this chart is also located on the access panel of the ventilator.

Note: To perform a proper installation, the External Static Pressure (ESP) needs to be measured at each of the 4 stations. Proceed to measure the Delta P (DP) to determine the corresponding airflow (e.g. 50 CFM), then repeat until the unit is balanced for both the ESP and airflows.

Balancing Chart when using collar pressure taps.					
Pressure		Fresh Air		Exhaust Air	
Pa	in. wg	L/s	CFM	L/s	CFM
50	0.20	44	93	43	90
62	0.25	41	87	40	85
75	0.30	39	83	37	79
87	0.35	37	79	36	77
100	0.40	35	74	36	76
112	0.45	33	69	34	71
125	0.50	30	65	32	67
137	0.55	29	61	28	60
150	0.60	26	56	24	51
162	0.65	24	50	22	47
175	0.70	22	46	19	41
187	0.75	19	41	17	36
199	0.80	17	36	15	31



TROUBLESHOOTING

Question / Item	Diagnosis / Solution
<ul style="list-style-type: none"> Ventilator not running 	<ul style="list-style-type: none"> Verify breaker in main electrical panel Verify the HRV or ERV is in the ON position Verify all wall controls connected to the ventilator are activated to supply power to the unit Unplug ventilator and verify that the wall control is wired correctly to the connection box on the side of the unit Verify main outlet polarization
<ul style="list-style-type: none"> Air is too dry 	<ul style="list-style-type: none"> Increase the humidity level on the wall control (Turn dial towards 60%) Reduce continuous airflow rate Switch ventilation mode from continuous to intermittent Increase the humidity level in the home by installing a whole-home humidifier
<ul style="list-style-type: none"> Air too humid 	<ul style="list-style-type: none"> Suggest continuous operation of ventilator Reduce humidity setting on the wall control (Turn dial towards 30%) Increase continuous airflow rate (ventilator fan speed) Insufficient ventilation, check that the capacity of the ventilator is sufficient for the size of the home Internal source of moisture, e.g. heating wood stove in basement, possible water leaks in foundation or poor insulation R-value and or clothes dryer is venting in basement
<ul style="list-style-type: none"> Vibration or noise 	<ul style="list-style-type: none"> Verify that the correct mounting equipment (wall-mounting bracket) was used when hanging the ventilator. Verify that a section of flexible duct is installed between the ventilator and the rigid duct. Verify that the motors are operating properly and the fans are rotating freely and are not obstructed by any debris
<ul style="list-style-type: none"> Cold air 	<ul style="list-style-type: none"> Misplaced supply outlets Defrost not operating correctly The ventilator is not properly balanced High airflow on furnace continuous mode Ensure ventilator is interlocked when integrated with forced-air system
<ul style="list-style-type: none"> Pollutants 	<ul style="list-style-type: none"> Ensure proper clearance of ventilation hoods from source of pollutants Refer to section "Installing Ventilation Hoods for Fresh Air and Exhaust"
<ul style="list-style-type: none"> Condensation 	<ul style="list-style-type: none"> Verify that the ventilator is level to ensure proper drainage Verify that the duct connections are secured with screws to the ventilator. Verify the fresh (supply) side duct connections are fully insulated and that the home has a properly-installed vapor barrier to ensure the home is sealed tightly. Look for any sections of crushed ducting, failing duct straps, punctured vapor barrier, or missing insulation. Look for signs of water accumulation/leakage/dripping Ensure proper seal of vapor barrier to outside wall. Verify that the drain connection is not kinked; i.e. that the "P" trap is not too close to the ventilator or is blocked with debris.

MAINTENANCE



Routine Maintenance

Seven-Step Maintenance Schedule

With routine preventative maintenance, you can avoid unnecessary problems, ensure the effectiveness of your ventilator, and prolong its life.

⚠ WARNING!

BE SURE TO DISCONNECT THE ELECTRICAL POWER BEFORE SERVICING YOUR SYSTEM

1. Clean or replace air filters

Filters, which are located within the ventilator, should be cleaned every two to three months. Filters should be vacuumed first, then washed with a mild soap and water. Most washable filters will last several years before needing to be replaced.

2. Clean the exterior intake and exhaust vents of obstructions

Check the outside vents regularly to ensure that the screen openings are not obstructed by grass, bushes, leaves, snow or other debris.

3. Clean and inspect the heat-exchange core

Do this twice a year and clean the core as required. Consult the Installation and Operation manual for instructions on inspecting and cleaning the core. A build-up of dust and dirt can restrict airflow and reduce the efficiency of the ventilator. After inspection and cleaning, make sure the core is replaced right-side-up.

4. Clean the condensate drain and pan

Twice a year, check the condensate drain, pan and tubing to ensure that they are open and free-flowing. The tubing can be disconnected for cleaning. The condensate drain must have a “trap” in the tubing that traps a quantity of water and helps prevent unpleasant odors from entering the ventilator via this tubing.

5. Inspect the fans

The fan motors on the ventilator are designed to operate continuously without lubrication and should not require inspection. Inspect the blower fans periodically for dirt on the blades, and remove it by gently brushing the blades or using a vacuum cleaner.

6. Clean the grilles and inspect the ductwork

Clean the grilles when they are dusty. At least once a year, visually inspect the ductwork leading to and from the ventilator. Damaged ducts can lead to condensation problems, including wet insulation, water on the floor and, ice build-up.

7. Arrange for an annual servicing

Your ventilator should undergo annual general servicing by a certified contractor who is familiar with its operation. If possible, have your furnace and ventilator serviced at the same time.

Daikin reserves the rights to modify a product, without prior notice, whether in price, design, color or codes, in order to offer at all times quality products that are highly competitive.

Install and service this equipment in compliance with applicable national and local building and safety codes.

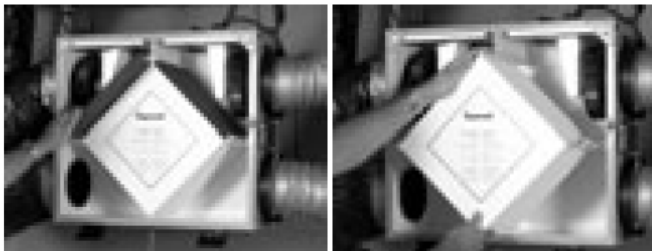

1. Slide out the filters.

2. Slide out the energy core.



3. Vacuum the filters.

4. Wash out the walls of the unit.

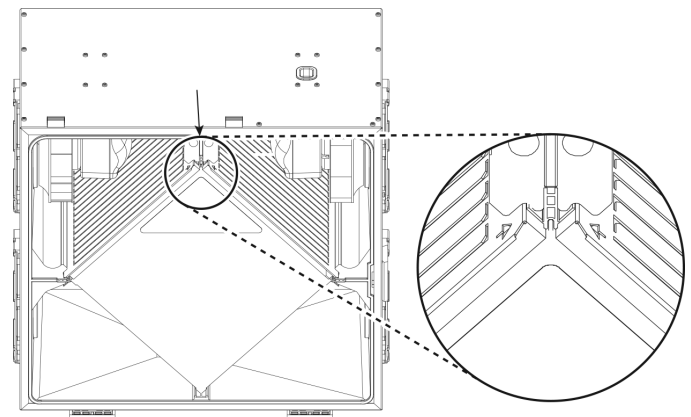

Louver Orientation



WARRANTY

Limited Warranties

Coverage

Daikin North America LLC (“Daikin”) warrants this product, to the original consumer, to be free from defects in materials and workmanship under normal use and service, for the applicable time periods listed below.

Warranty Period (Years after installation)			
Product	Ventilation motors	Heat Exchange Core	Controls, sensor and electronics
VH30100	5	As long as the original owner owns the product (Polypropylene heat recovery core)	5
VH30120R	5		5
VH70220	10		5
VH30160	10		5
VH30160R	10		5
VH30160NC	2		2
VH70220NC	2		2
VE30100	5	5 (Enthalpy energy recovery core)	5
VE30160	10		5
VE70220	10		5

Terms Applicable to All Warranties

THE WARRANTIES SET FORTH HEREIN ARE THE ONLY EXPRESS WARRANTIES ON THE PRODUCT, AND DAIKIN EXPRESSLY LIMITS THE DURATION OF ANY IMPLIED OR STATUTORY WARRANTIES, INCLUDING BUT NOT LIMITED TO ANY WARRANTIES OF MERCHANTABILITY, WORKMANSHIP, OR FITNESS FOR A PARTICULAR USE, TO THE DURATION OF THE APPLICABLE EXPRESS WARRANTY. Some states and provinces do not allow limitations on how long an implied warranty lasts, so the above limitation may not apply to you.

Daikin’s exclusive obligation, and the purchaser’s only remedy, under these warranties shall be for Daikin to supply, without charge, a new or remanufactured replacement for any covered component or part of the product which is found to be defective within the applicable warranty period; provided, however, that Daikin reserves the option to repair and return the defective part or component. None of these warranties

include labor or other costs incurred for diagnosing, repairing, removing, installing, shipping, servicing or handling of either defective parts/components or replacement parts/components. DAIKIN SHALL NOT HAVE ANY OTHER RESPONSIBILITY, INCLUDING ANY LIABILITY FOR INCIDENTAL OR CONSEQUENTIAL DAMAGES, RESULTING DIRECTLY OR INDIRECTLY FROM ANY BREACH OF WARRANTY, EXPRESS OR IMPLIED, OR OTHER CONTRACT BREACH, NEGLIGENCE OR OTHER TORT. Some states and provinces do not allow the exclusion or limitation of incidental or consequential damages, so the above exclusion may not apply to you. Any part replaced pursuant to this warranty is warranted only for the unexpired portion of the warranty term applying to the original part.

Warranties apply only to products installed in their original location. Installation, use, care, and maintenance must be normal and in accordance with instructions contained in the Owner’s Manual and service information. Defective parts must be returned to the distributor through a registered servicing dealer for credit. All work shall be performed by a state-licensed technician. Replacement parts replaced after expiration of the previously applicable limited warranty period (if any) are warranted for a period of one year.

Daikin will not be responsible for normal maintenance, installation, including filter cleaning and/or replacement, damage or repairs required as a consequence of faulty installation, misapplication, abuse, improper servicing, unauthorized alteration or improper operation, damage as a result of floods, winds, fires, lightning, accidents, corrosive environments or other conditions beyond the control of Daikin, parts not supplied or designated by Daikin, or damages resulting from their use.

This warranty gives you specific legal rights, and you may also have other rights which vary from state to state or province to province.

Upon notice of warranted failure, information should be gathered specific to the cause and results of the failure. Warranty claim request must be filed within 30 days of failure.

Contact Daikin Technical Support Line at 1-888-724-5211 and explain the situation, including model and serial number of the machine. We will advise as to proper procedures to either repair or replace as necessary and the warranty coverage available. Important - the unit model as well as the serial number must be stated to ensure replacement parts are accurate.

DAIKIN NORTH AMERICA LLC

480 Ferdinand Blvd.
 Dieppe, New Brunswick Canada E1A 6V9
 1-888-724-5211



VENTILATORS