

System Protection Devices

Pressure Relief Valves

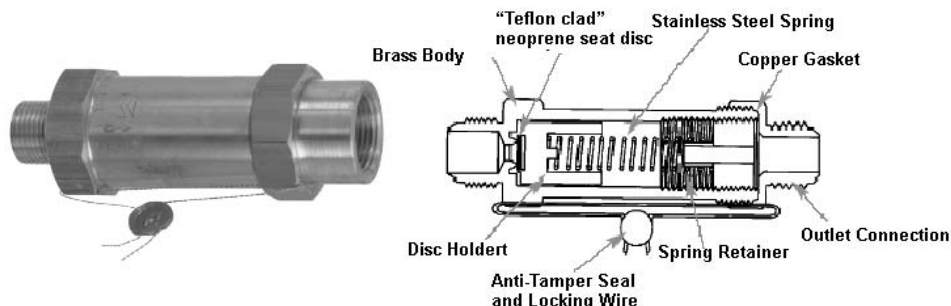

Mueller pressure relief valves are designed primarily for use on liquid receiver applications, above the liquid Refrigerant level, and it is recommended that the factory be consulted before the valves are used on other applications. These valves are designed to operate according to ASHRAE Standard 15, they should be applied According to this safety code. Application information can also be found in the ASHRAE Guide and Data Book.

How to select a relief valve:

- Determine the minimum discharge capacity required.
- Determine pressure setting. This relief setting cannot exceed the design pressure of the liquid receiver. However, the relief valve setting should be at least 25% higher than the maximum system operating pressure.
- Determine the size connection required.
- Select valve from chart below.

Discharge Capacity

The minimum required discharge capacity of the pressure relief device or fusible plug for each pressure vessel is Determined by the following formula, specified by the ASHRAE Standard 15, Safety Code for Mechanical Refrigeration:

$C = kfDL$ where:

C = minimum required discharge capacity of the relief device, lb. air/min (kg air/min)

D = outside diameter of vessel, ft (m)

L = length of the vessel, ft (m)

k = factor dependent on units used (k = 1 for I-P units, k = 4.88 for SI units)

f = factor dependent on the kind of refrigerant from the chart below

DISCHARGE CAPACITY													
PSIG	Prefix	A		B		C		D		E		F	
		lb air/min	kg air/min	lb air/min	kg air/min	lb air/min	kg air/min	lb air/min	kg air/min	lb air/min	kg air/min	lb air/min	kg air/min
235	AD	4.3	2.0	9.1	4.1	20.1	9.1	33.7	15.3	55.9	25.4	91.8	41.6
300	AE	5.4	2.4	11.5	5.2	25.4	11.5	42.5	19.3	70.5	32.0	115.8	52.5
350	AG	6.3	2.9	13.3	6.0	29.5	13.4	49.3	22.4	81.8	37.1	134.3	60.9
400	AH	7.1	3.2	15.2	6.9	33.5	15.2	56.1	25.4	93.0	42.2	152.7	69.3
425	AI	7.6	3.4	16.1	7.3	35.6	16.1	59.5	27.0	98.6	44.7	162.0	73.5
450	AJ	8.0	3.6	17.0	7.7	37.6	17.1	62.9	28.5	104.3	47.3	171.2	77.7

Type of Refrigerant	Value of f
<i>When used on the lowside of a limited-charge cascade system</i>	<i>(Value in parentheses is metric)</i>
R-23, R-170, R-744, R-1150, R-508, R-508B	1.0(0.082)
R-13, R-13B1, R-503	2.0(0.163)
R-14	2.5(0.203)
<i>Other Applications:</i>	
R-718	0.2(0.016)
R-717	0.5(0.041)
R-11, R-32, R-113, R-123, R-142b, R-152a, R-290, R-600, R-600a, R-764	1.0(0.082)
R-12, R-22, R-114, R-124, R-134a, R-410A, R-104B, R-401C, R-405A, R-406A, R-407C, R-407D, R-407E, R-409A, R-409B, R-411A, R-411B, R-411C, R-412A, R-414A, R-414B, R-500, R-1270	1.6(0.131)
R-143a, R-402B, R-403A, R-407A, R-408A, R-413A	2.0(0.163)
R-115, R-402A, R-403B, R-404A, R-407B, R-410A, R-410B, R-502, R-507A, R-509A	2.5(0.203)

System Protection Devices

Pressure Relief Valves

Straight Thru - NPTFE Inlet to Flare

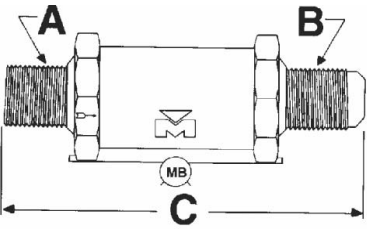

ASME VALVE	INLET (A) (in)	OUTLET (B) (in)	C		DISCHARGE TABLE	(lb)	(kg)
			(in)	(cm)			
A 15501	1/4	3/8	2-21/32	6.75	A	0.19	0.09
A 15502	3/8	3/8	2-13/16	7.14	B	0.33	0.15
A 15503	3/8	1/2	3	7.62	B	0.36	0.16
A 15504	1/2	5/8	4-3/16	10.64	C	0.84	0.38
B 33752	1/4	3/8	2-13/16	7.14	B	0.32	0.14
B 33753	1/4	1/2	3	7.62	B	NA	NA

Angle - NPTFE to Flare

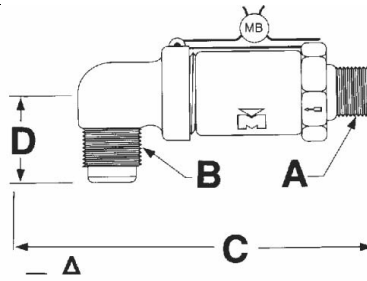

ASME VALVE	INLET (A) (in)	OUTLET (B) (in)	C		D		DISCHARGE TABLE	WT/ EA	
			(in)	(cm)	(in)	(cm)		(lb)	(kg)
B 33746	1/4	3/8	2-3/8	6.03	1-1/8	2.86	B	0.30	0.14
B 33754	1/4	1/2	2-7/16	6.19	1-5/16	3.33	B	NA	NA
A 15512	3/8	3/8	2-3/8	6.03	1-3/8	3.49	B	0.36	0.16
A 15513	3/8	1/2	2-3/8	6.03	1-11/32	3.41	B	0.38	0.17
A 15514	1/2	5/8	4-3/32	10.40	1-9/16	3.97	C	0.98	0.45

Atmospheric - NPTFE Inlet

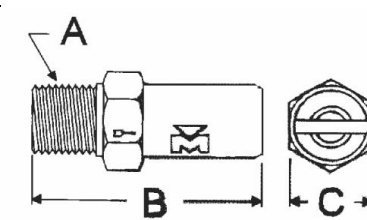

ASME VALVE	INLET (A) (in)	B (in)	C		DISCHARGE TABLE	(lb)	(kg)
			(in)	(cm)			
A 15508	1/8	1-7/8	3/4	1.91	A	0.12	0.05
A 15509	1/4	2	3/4	1.91	A	0.13	0.06
A 17430	3/8	2-1/8	1	2.54	B	0.24	0.11
B 33755	1/4	2-1/8	1	2.54	B	NA	NA

Straight Thru - NPTFE Inlet to NPTFI Outlet

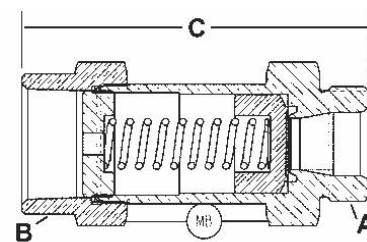

ASME VALVE	INLET (A) (in)	OUTLET (B) (in)	C		DISCHARGE TABLE	(lb)	(kg)
			(in)	(cm)			
A 17840	1	1	4-9/16	11.59	E	1.95	0.88
A 17834	1-1/4	1-1/4	5	12.70	F	2.00	0.91
A 15506	3/4	3/4	5	12.70	D	1.49	0.68

Straight Thru-Straight Thread Inlet to NPTFI Outlet

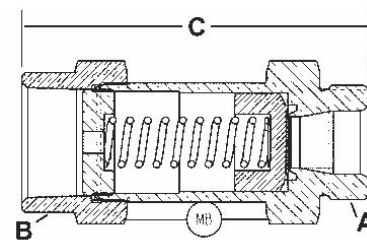

ASME VALVE	INLET (A) (in)	OUTLET (B) (in)	C		DISCHARGE TABLE	(lb)	(kg)
			(in)	(cm)			
B 34444	7/8 -14 UNF 2A	3/4	5	12.70	D	1.53	0.69
B 34519	1-5/16 -12UNF2A	1	4-3/8	11.11	E	1.37	0.62
B 34580	1-5/8 -12UNF-2A	1-1/4	5	12.70	F	2.00	0.91

Prefixes for standard settings are:

AD/BD= 235 psig.

AE/BE = 300 psig.

AG/BG = 350 psig.

AH/BH = 400 psig.

AI/BI = 425 psig.

AJ/BJ = 450 psig.

For valves furnished at non-standard settings, use part numbers as listed in specification charts and indicate exact pressure setting.