



WHITE-RODGERS

50A22-4

Pilot Relight/Timer Control
INSTALLATION INSTRUCTIONS

Operator: Save these instructions for future use!

FAILURE TO READ AND FOLLOW ALL INSTRUCTIONS CAREFULLY BEFORE INSTALLING OR OPERATING THIS CONTROL COULD CAUSE PERSONAL INJURY AND/OR PROPERTY DAMAGE.

DESCRIPTION

The 50A22 relight/timer control is energized by the thermostat on a heat call, generates ignition sparks and provides a timer function. Once a flame is established, the 50A22 stops sparking. The timer measures the amount of time required for the pilot flame to heat the sensor and cause it to switch the main gas valve on. If the pilot flame does not cause the sensor to switch within 2 minutes, the contacts will open and de-energize the gas valve, stopping all gas flow. If the pilot flame is extinguished during a heat call, the relight/timer control will begin to spark the instant a flame is not detected. It delivers very low current sparks at approximately 6,000 volts. When the 3098 flame sensor switches the main valve on, the timer is switched to the standby mode.

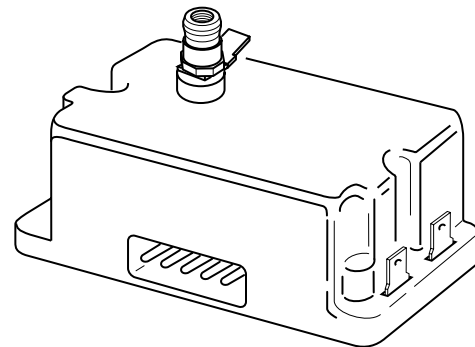

PRECAUTIONS

Do not exceed the specification ratings.

All wiring must conform to local and national electrical codes and ordinances.

This control is a precision instrument, and should be handled carefully. Rough handling or distorting components could cause the control to malfunction.

⚠ WARNING

Do not use on circuits exceeding specified voltage. Higher voltage will damage the control and may cause shock or fire hazard.

⚠ CAUTION

To prevent electrical shock and/or equipment damage, disconnect electrical power to the system, at the main fuse or circuit box, until installation is complete.

Do not short out terminals on gas valve or primary control to test. Short or incorrect wiring can cause equipment damage, property damage, and/or personal injury.

This control is not intended for use in locations where it may come in direct contact with water. Suitable protection must be provided to shield the control from exposure to water (dripping, spraying, rain, etc.).

Label all wires prior to disconnection when servicing controls. Wiring errors can cause improper and dangerous operation.

Following installation or replacement, follow appliance manufacturers' recommended installation/service instructions to insure proper operation.



WHITE-RODGERS DIVISION
EMERSON ELECTRIC CO.
9797 REAVIS ROAD
ST. LOUIS, MISSOURI 63123-5398

Printed in U.S.A.

PART NO. 37-5440A

9512

SPECIFICATIONS

Electrical Rating: 60 Hz., 0.030A @ 30 VAC Max.

Ambient Temp.: 32° to 150°F

Mounting: Surface or 2" x 4" box

Spark Circuit

Flame Failure Response Time: 0.8 sec.

Recycle Time: 0.8 sec.

Spark Gap: $\frac{3}{32}$ " to $\frac{5}{32}$ "

System Timing:

Flame Establishing Period: 90 sec.

Timer:

Trial for Ignition Time:* 150 sec.

Reset Time: 5 min.

* Max. time allowed for system to establish pilot and switch main burner on

INSTALLATION

1. Turn off power to the system at the main fuse or breaker box before beginning installation.
2. Mount the 50A22 relight/timer control in an area on the appliance where it will not be affected by rollout flame, flame heat, or radiant heat. Maximum ambient temperature should not exceed 155° F.
 - a. Be sure metal-to-metal contact is made between mounting hole standoffs on 50A22 and mounting surface.
 - b. Connect the high voltage lead to the terminal on top of the 50A22, after feeding the lead through the angled insulation boot. Press the boot over the connection (see fig. 2). Avoid excessive strain on the ignition cable, as this may cause the cable to pull out of the ceramic. (The ignition cable is held in the ceramic by a push-on connector.)
3. Plug the 5-wire connector from the gas valve wiring harness into the receptacle on the 50A22. Be sure metal clips in 5-wire plug are aligned.
4. If replacing a 24 volt gas valve, attach wires previously connect to **old** gas valve to the terminals on the 50A22 Relight/Timer. If replacing other control configurations, refer to figures 4 and 5 for **typical** wiring.
5. Refer to fig. 3 for **typical** system wiring hookup. When wiring this system, be sure the limit control is **not accidentally wired out of the circuit**.
6. Inspect all existing wiring for damage, loose connections, etc. Secure all wiring to chassis or piping with electrical/friction tape or plastic wire-wraps so they will not be able to contact high temperature locations.

⚠ CAUTION

Do not jumper or accidentally short terminals on 50A22 Relight/Timer. This may cause the room thermostat heat anticipator to BURN OUT.

7. Turn on power to the system. Test system operation by adjusting room thermostat to call for heat.
8. The 50A22 should begin sparking. Make sure sparking occurs between the ignition electrode and the mercury flame sensor or pilot hood, in the middle of the gas stream. The spark gap must be $\frac{3}{32}$ " to $\frac{5}{32}$ ". If electrode placement is not correct, **disconnect power** and re-position the electrode.

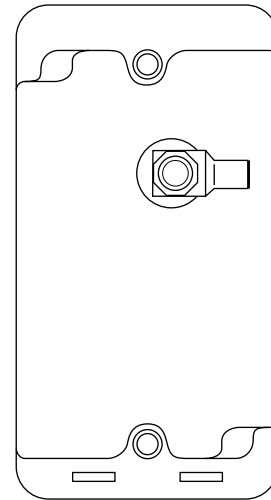

Figure 1. 50A22-4 Pilot Relight Control (top view)

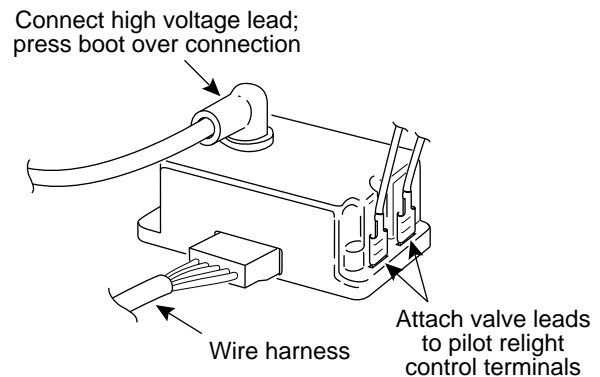

Figure 2. 50A22 Pilot relight/timer connections

NOTE

The timer will lock out in approximately two minutes and the gas valve will be de-energized if the pilot flame has not been established and the 3098 mercury flame sensor has not switched to **ON**. When this occurs, turn off power to the system for at least five minutes. Then turn on power to the system and attempt re-ignition.

- As soon as a pilot flame is established, sparks from the 50A22 should stop. If sparking does not stop, make sure the ignition electrode is in the pilot flame and metal standoffs on the 50A22 are properly grounded (**scrape the paint under the standoffs to ensure a good ground connection**).

NOTE

Figures 3, 4, and 5 show **typical** system wiring and hookup. Always refer to equipment manufacturer's instructions for specific wiring and hookup.

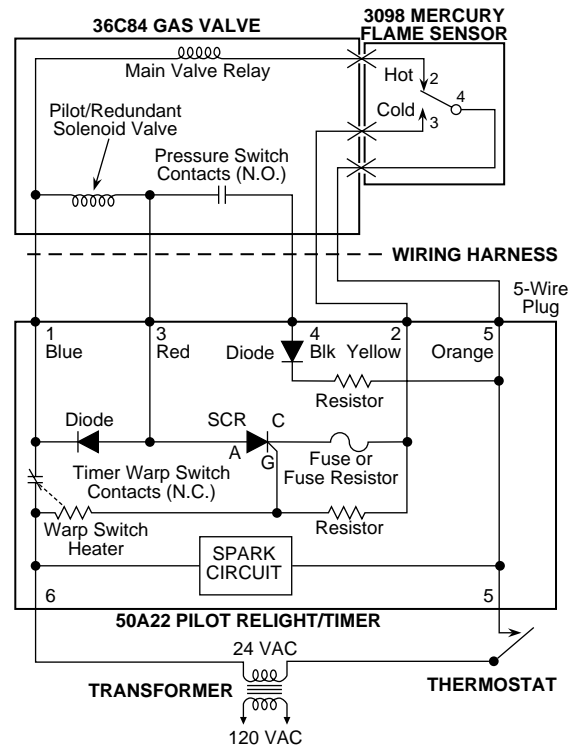

Figure 3. Typical system component wiring diagram

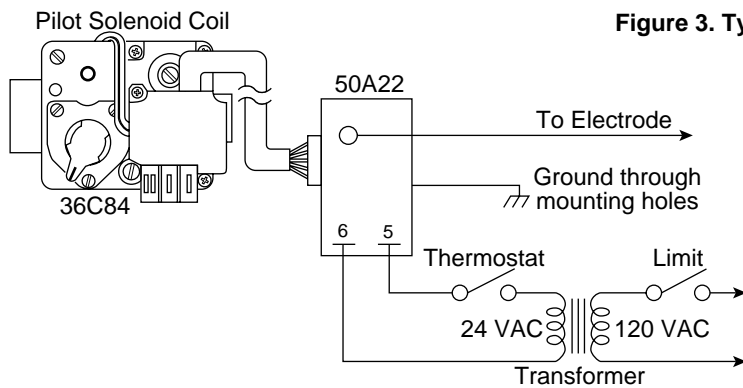

Figure 4. Typical wiring/hookup for low voltage thermostat and line voltage limit

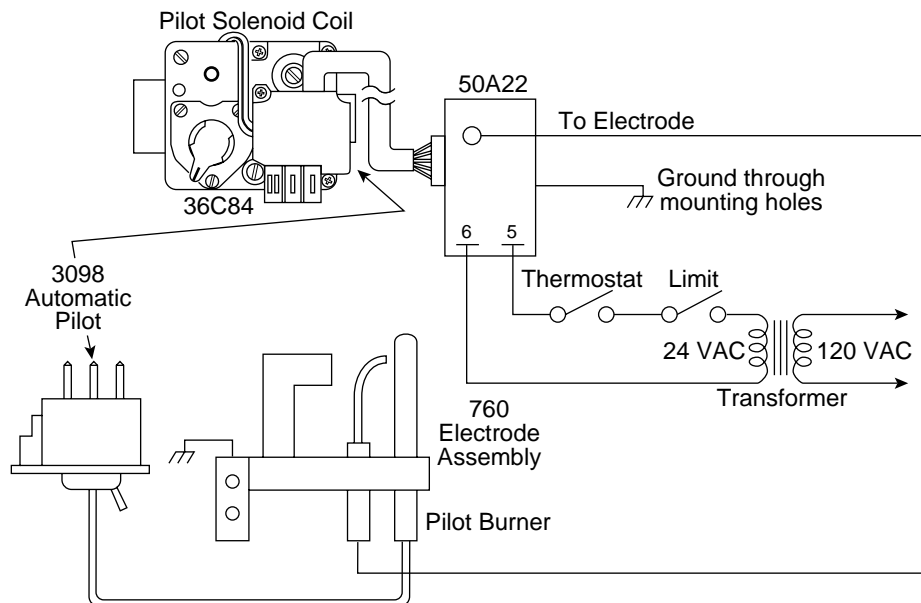

Figure 5. Typical low voltage wiring/hookup

If you need further information about this product, please write to

White-Rodgers Division, Emerson Electric Co.
9797 Reavis Road
St. Louis, MO 63123-5398
Attention: Technical Service Department