

TRADELINE

VR8304M Intermittent Pilot Combination Gas Control

Application

These intermittent pilot gas controls are used in gas-fired appliances with capacities up to 300 feet³/hour at 1 inch wc pressure drop [8.5 meters³/hour at 0.25 kPa] on natural gas. They include a manual valve, two automatic operators, pressure regulator, and a pilot adjustment. See Table 1 for temperature range and regulator type. The VR8304M setup for natural gas includes a 393691 LP conversion kit. The kit contains a new cap screw, pressure regulator adjustment screw, a tapered spring, and a conversion label. The control

must be equipped with a standard servo pressure regulator. BODY PATTERN: Straight-through body pattern.

INLET x OUTLET SIZES AVAILABLE: 1/2 x 1/2 inch, 1/2 x 3/4 inch, and 3/4 x 3/4 inch (factory-installed inlet flange).

ADAPTERS: Adapters available for 3/8, 1/2 and 3/4 inch straight and angle connections. Refer to Table 2.

ELECTRICAL RATINGS:

VOLTAGE AND FREQUENCY: 24 Vac, 60 Hz.

CURRENT DRAW: 0.7A.

CAPACITY:

Size (Inlet x Outlet)	Capacity at 1 inch wc Pressure Drop ^a	Minimum Regulated Capacity	Maximum Regulated Capacity
1/2 x 1/2	240 feet ³ /hour [6.8 meter ³ /hour]	30 feet ³ /hour [0.8 meter ³ /hour]	340 feet ³ /hour [9.6 meter ³ /hour]
1/2 x 3/4	270 feet ³ /hour [7.6 meter ³ /hour]	30 feet ³ /hour [0.8 meter ³ /hour]	370 feet ³ /hour [10.5 meter ³ /hour]
3/4 x 3/4	300 feet ³ /hour [8.5 meter ³ /hour]	30 feet ³ /hour [0.8 meter ³ /hour]	415 feet ³ /hour [11.8 meter ³ /hour]

^a Capacity based on 1000 Btu/feet³, 0.64 specific gravity natural gas at 1 inch wc pressure drop [37.3 MJ/meter³, 0.64 specific gravity natural gas at 0.25 kPa pressure drop].

Use conversion factors in Table 3 to convert capacities for other gases.

TABLE 1—TEMPERATURE RANGE AND REGULATOR TYPE.

Model Number	Ambient Temperature Range	Regulator Type
VR8304M	-40° F to 175° F [-40° C to +79° C]	Standard-opening

TABLE 3—GAS CAPACITY CONVERSION FACTORS.

Gas	Specific Gravity	Multiply Listed Capacity By
Manufactured	0.60	0.516
Mixed	0.70	0.765
Propane	1.53	1.62

APPROVALS:

American Gas Association Design Certificate:

UP-70-69A.

Canadian Gas Association Design Certificate:

UP-70-69A.

Australian Gas Association Design Certificate:

Applied for.

DELTA C: P-70-42A19.

TABLE 2—ADAPTER (FLANGE) PART NUMBERS.

Inlet/ Outlet Pipe Size	Flange Type	Part Number	
		Without Hex Wrench	With Hex Wrench
1/2 inch NPT	Straight	393690-6	393690-16
	Elbow	393690-3	393690-13
3/4 inch NPT	Straight	393690-4	393690-14
	Elbow	393690-5	393690-15

NOTE: Flange kits include one flange with attached O-ring and four mounting screws.

Installation

CONVERTING BETWEEN NATURAL AND LP GAS

WHEN INSTALLING THIS PRODUCT...

1. Read these instructions carefully. Failure to follow them could damage the product or cause a hazardous condition.
2. Check the ratings given in the instructions and on the product to ensure the product is suitable for your application.
3. Ensure installer is a trained, experienced service technician.
4. After installation is complete, use these instructions to check out product operation.



WARNING

FIRE OR EXPLOSION HAZARD CAN CAUSE PROPERTY DAMAGE, SEVERE INJURY, OR DEATH

Follow these warnings exactly.

1. Disconnect power supply before wiring to prevent electrical shock or equipment damage.
2. To avoid dangerous accumulation of fuel gas, turn off gas supply at the appliance service valve before starting installation, and perform Gas Leak Test after completion of installation.
3. Do not bend pilot tubing at gas control or pilot burner after compression fitting has been tightened, or gas leakage at the connection may result.
4. Always install sediment trap in gas supply line to prevent contamination of gas control.
5. Do not force the gas control knob. Use only your hand to turn the gas control knob. Never use any tools. If the gas control knob will not operate by hand, the gas control should be replaced by a qualified service technician. Force or attempted repair may result in fire or explosion.



CAUTION

Never apply a jumper across or short the valve coil terminals. This may burn out the heat anticipator in the thermostat or damage the electronic intermittent pilot (IP) module.

IMPORTANT: *These gas controls are shipped with protective seals over inlet and outlet tappings. Do not remove seals until ready to connect piping.*

Follow the appliance manufacturer's instructions if available; otherwise, use the instructions provided below.



WARNING

FIRE OR EXPLOSION HAZARD CAN CAUSE PROPERTY DAMAGE, SEVERE INJURY, OR DEATH

1. Do not attempt to use a gas control set for natural gas on LP gas or a gas control set for LP gas on natural gas.
2. When making conversion, main and pilot burner orifices **MUST** be changed to meet appliance manufacturer's specifications.

Standard- or slow-opening gas controls may be converted from one gas to another. To convert from natural gas to LP use the 393691 LP Conversion Kit that is included with the VR8304M Gas Control. To convert from LP to natural gas use the 394588 Natural Gas Conversion Kit (order separately). Step-opening gas controls can not be converted.

To convert control from one gas to another:

1. Turn off main gas supply to the appliance.
2. Remove the regulator cap screw and pressure regulator adjusting screw. See Fig. 1.

Fig. 1—Top view of gas control.

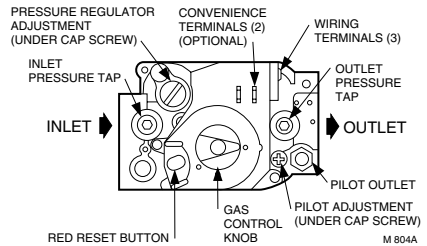

3. Remove the existing spring.
4. Insert the replacement spring with tapered end down. See Fig. 2.
5. Install the new plastic pressure regulator adjustment screw so that the top of the screw is flush (level) with the top of the regulator. Turn the pressure regulator adjustment screw clockwise  six complete turns. This provides a preliminary pressure setting of about 10.0 in. wc [2.5 kPa] for LP regulator and 3.5 in. wc [0.9 kPa] for natural gas regulator.
6. Check the regulator setting either with a manometer or by clocking the gas meter. Refer to Start-up and Check-out on Page 5.
7. Install the new cap screw.
8. Mount conversion label on control.
9. Install control and appliance according to appliance manufacturer's instructions.

Fig. 2—Installation of conversion kit in regulated gas control.



INSTALL BUSHINGS TO GAS CONTROL

1. Remove seal over gas control inlet or outlet.
2. Apply moderate amount of good quality pipe compound to bushing, leaving two end threads bare. On LP installation, use compound resistant to LP gas. Do NOT use Teflon tape.
3. Insert bushing in gas control and thread pipe carefully into bushing until tight.

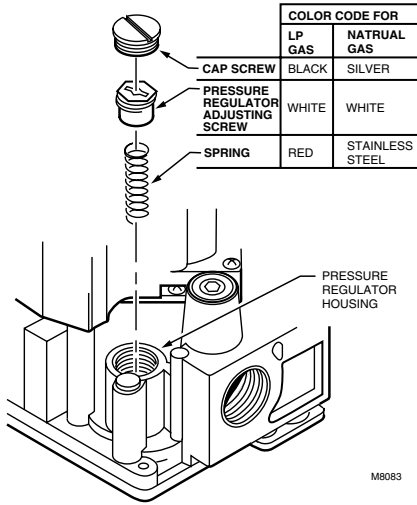
USING ADAPTERS TO SOLVE SWING RADIUS PROBLEMS

In some field service applications, it is difficult or impossible to thread the gas control onto the gas supply pipe because of space limitations. This problem can be resolved in many instances by using an adapter. The adapter is installed on the end of the supply pipe in place of the gas control, following the same precautions and instructions that are used for installing the gas control. After the adapter is installed, the gas control is attached to the adapter as outlined above. Note that using an adapter increases the overall length of the gas control.

CHOOSE GAS CONTROL LOCATION

Do not locate the gas control where it may be affected by steam cleaning, high humidity, dripping water, corrosive chemicals, dust or grease accumulation, or excessive heat. To ensure proper operation, follow these guidelines:

- Locate gas control in a well ventilated area.
 - Mount gas control high enough above the cabinet bottom to avoid exposure to flooding or splashing water.
 - Ensure the ambient temperature does not exceed the ambient temperature ratings for each component.
 - Cover gas control if appliance is cleaned with water, steam, or chemicals or to avoid dust and grease accumulation.
 - Avoid locating gas control where exposure to corrosive chemical fumes or dripping water are likely.
- Locate the gas control in the appliance vestibule on the

gas manifold. In replacement applications, locate the gas control in the same location as the old gas control.

Install Piping to Gas Control

All piping must comply with local codes and ordinances or with the National Fuel Gas Code (ANSI Z223.1 NFPA no. 54 whichever applies). Tubing installation must comply with approved standards and practices.

1. Use new, properly reamed pipe free from chips. If tubing is used, ensure the ends are square, deburred and clean. All tubing bends must be smooth and without deformation.
2. Run pipe or tubing to the gas control. If tubing is used, obtain a tube-to-pipe coupling to connect the tubing to the gas control.
3. Install sediment trap in the supply line to the gas control. See Fig. 3.

Fig. 3—Install sediment trap.

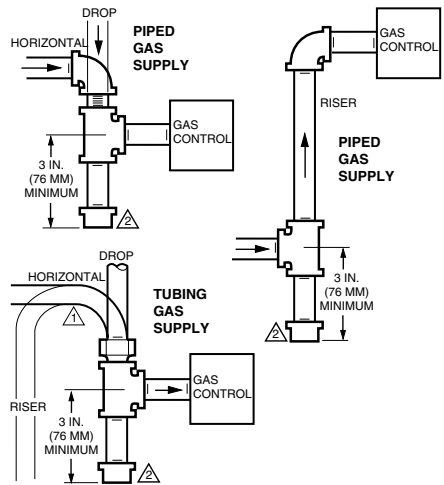

- ⚠ ALL BENDS IN METALLIC TUBING SHOULD BE SMOOTH.
- ⚠ CAUTION: SHUT OFF THE MAIN GAS SUPPLY BEFORE REMOVING END CAP TO PREVENT GAS FROM FILLING THE WORK AREA. TEST FOR GAS LEAKAGE WHEN INSTALLATION IS COMPLETE. M3077

Install Gas Control

1. Mount the gas control 0-90 degrees, in any direction, from the upright position of the gas control knob, including vertically.
2. Mount the gas control so gas flow is in the direction of the arrow on the bottom of the gas control.
3. Thread pipe the amount shown in Table 4 for insertion into the gas control or adapter. DO NOT THREAD PIPE TOO FAR. Valve distortion or malfunction may result if the pipe is inserted too deeply into the gas control.
4. Apply a moderate amount of good quality pipe compound (DO NOT use Teflon tape) to pipe only, leaving two end threads bare. On LP installations, use compound resistant to LP gas. Refer to Fig. 4.
5. Remove seals over gas control inlet and outlet if necessary.
6. Connect pipe to gas control inlet and outlet. Use

wrench on the square ends of the gas control. If an adapter is used, place wrench on adapter rather than gas control. Refer to Figs. 1 and 5.

Fig. 4—Use moderate amount of pipe compound.

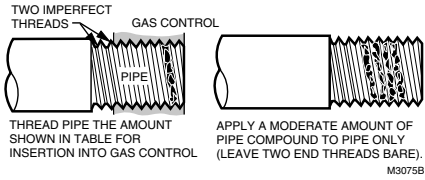

TABLE 4—NPT PIPE THREAD LENGTH IN INCHES.

Pipe Size	Thread Pipe This Amount	Maximum Depth Pipe Can Be Inserted Into Control
3/8	9/16	3/8
1/2	3/4	1/2
3/4	13/16	3/4

Fig. 5—Proper use of wrench on gas control with flanges.

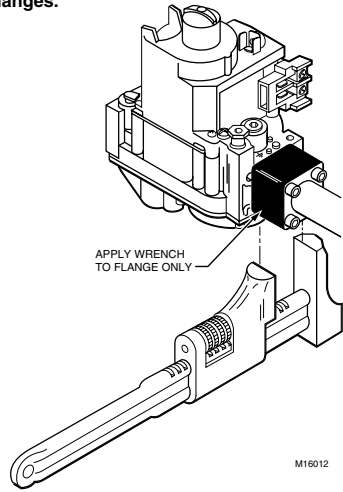

Fig. 6—Always use new compression fitting.

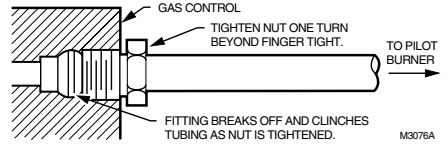
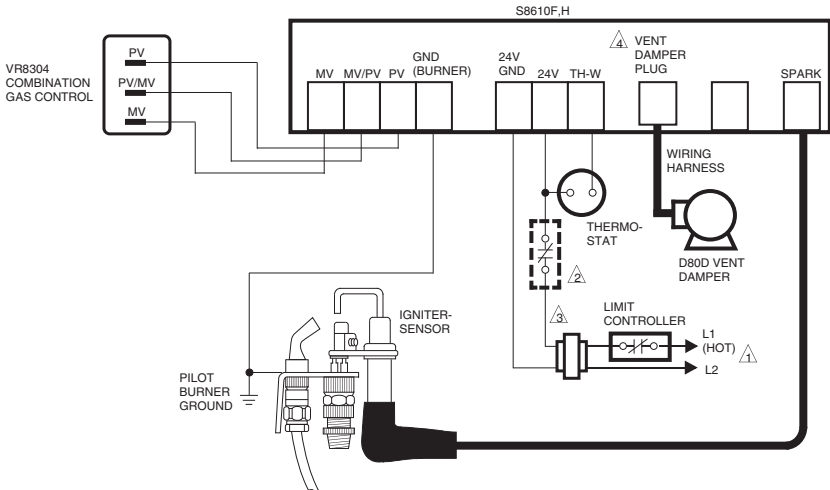

Fig. 7—VR8304 wiring connections in intermittent ignition system with S8600.



- ⚠ POWER SUPPLY. PROVIDE DISCONNECT MEANS AND OVERLOAD PROTECTION AS REQUIRED.
- ⚠ ALTERNATE LIMIT CONTROLLER LOCATION.
- ⚠ CONTROLS IN 24V CIRCUIT MUST NOT BE IN GROUND LEG TO TRANSFORMER.
- ⚠ REMOVE PLUG ONLY IF USING VENT DAMPER. FUSE BLOWS ON STARTUP WHEN PLUG IS REMOVED AND VENT DAMPER WIRING HARNESS IS INSTALLED; THEN MODULE WILL OPERATE ONLY WHEN VENT DAMPER IS CONNECTED.

M1507

Connect Pilot Gas Tubing

1. Cut tubing to desired length and bend as necessary for routing to pilot burner. Do not make sharp bends or deform the tubing. Do not bend tubing at gas control or pilot burner after compression fitting has been tightened, as this may result in gas leakage at the connection.

2. Square off and remove burrs from end of tubing.

3. Unscrew compression fitting from the pilot outlet (Fig. 1). Slip the compression fitting over the tubing and slide out of the way.

NOTE: When replacing a gas control, cut off old compression fitting and replace with the new compression fitting provided on the gas control. Never use the old compression fitting as it may not provide a gas-tight seal.

4. Push tubing into the pilot gas tapping on the outlet end of the control until it bottoms. While holding tubing all the way in, slide compression fitting into place and engage threads—turn until finger tight. Then tighten one more turn with wrench. Do not overtighten. Refer to Fig. 6.

5. Connect other end of tubing to pilot burner according to pilot burner manufacturer's instructions.

WIRING

Follow the wiring instructions furnished by the appliance manufacturer, if available, or use the general instructions provided below.

All wiring must comply with applicable electrical codes and ordinances.

Disconnect power supply before making wiring connections to prevent electrical shock or equipment damage.

1. Check the power supply rating on the gas control and ensure it matches the available supply. Install transformer, thermostat, and other controls as required.

2. Connect control circuit to gas control terminals. See Figs. 1 and 7.

3. Adjust thermostat heat anticipator to 0.70 rating stamped on valve operator.

Start-Up and Checkout



WARNING

**FIRE OR EXPLOSION HAZARD
CAN CAUSE PROPERTY DAMAGE,
SEVERE INJURY, OR DEATH**

1. Do not force the gas control knob. Use only your hand to turn the gas control knob. Never use any tools.
2. If the gas control knob will not operate by hand, the gas control should be replaced by a qualified service technician.

GAS CONTROL KNOB SETTINGS

The gas control knob has two settings:

- OFF—prevents pilot and main burner gas flow.
- ON—permits gas to flow into the control body.

Under control of the thermostat and intermittent pilot module, pilot and main burner gas flow is permitted.

NOTE: Gas controls are shipped with the gas control knob in the ON position.

TURN ON SYSTEM

Rotate the gas control knob counterclockwise ↶ to ON.

TURN ON MAIN BURNER

Follow instructions provided by appliance manufacturer or turn up thermostat to call for heat.

PERFORM GAS LEAK TEST



WARNING

**FIRE OR EXPLOSION HAZARD
CAN CAUSE PROPERTY DAMAGE,
SEVERE INJURY, OR DEATH**

Check for gas leaks with rich soap and water solution any time work is done on a gas control.

GAS LEAK TEST

1. Paint all pipe connections upstream of the gas control with a rich soap and water solution. Bubbles indicate a gas leak.

2. If a gas leak is detected, tighten the pipe connection.

3. Stand clear while lighting main burner to prevent injury caused from hidden gas leaks that could cause flashback in the appliance vestibule. Light the main burner.

4. With the main burner in operation, paint all pipe joints (including adapters) and gas control inlet and outlet with rich soap and water solution.

5. If another gas leak is detected, tighten adapter screws, joints, and pipe connections.

6. Replace the part if gas leak cannot be stopped.

ADJUST THE PILOT BURNER FLAME

The pilot flame should envelop 3/8 to 1/2 inch [10 to 13 millimeters] of the igniter-sensor tip. Refer to Fig. 8. To adjust the pilot flame:

1. Remove the pilot adjustment cover screw. Refer to Fig. 1.

2. Turn the inner adjustment screw clockwise ↷ to decrease or counterclockwise ↶ to increase the pilot flame.

3. Always replace the cover screw after adjustment and tighten firmly to ensure proper operation.

Fig. 8—Proper flame adjustment.

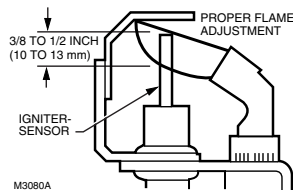



CHECK AND ADJUST GAS INPUT TO MAIN BURNER

! CAUTION

1. Do not exceed the input rating stamped on the appliance nameplate, or manufacturer's recommended burner orifice pressure for the size orifice used. Ensure the main burner primary air supply is properly adjusted for complete combustion (refer to the appliance manufacturer's instructions).
2. IF CHECKING GAS INPUT BY CLOCKING THE GAS METER:
 - Ensure that the *only* gas flow through the meter is that of the appliance being tested.
 - Ensure that other appliances are turned off and that their pilot burners are extinguished (or deduct their gas consumptions from the meter reading).
 - Convert the flow rate to Btuh as described in the Gas Controls Handbook (form number 70-2602) and compare to the Btuh input rating on the appliance nameplate.
3. IF CHECKING GAS INPUT WITH A MANOMETER (PRESSURE GAUGE):
 - Ensure the gas control knob is in the PILOT position before removing the outlet pressure tap plug to connect the manometer.
 - Turn the gas control knob back to PILOT when removing the manometer and replacing outlet pressure tap plug.
 - Shut off the gas supply at the appliance service valve or, for LP gas, at the gas tank before removing outlet the pressure tap plug and before disconnecting the manometer and replacing the outlet pressure tap plug.
 - Perform the Gas Leak Test at the inlet pressure tap plug.

Standard-Opening and Slow-Opening Pressure Regulator

1. The gas control outlet pressure should match the manifold pressure listed on the appliance nameplate.
2. With the main burner operating, check the gas control flow rate using the meter clocking method or check the gas pressure using a manometer connected to the gas control outlet pressure tap. Refer to Fig. 1.
3. If necessary, adjust the pressure regulator to match the appliance rating. Refer to Table 5 or 6 for the factory set nominal outlet pressures and adjustment ranges.
 - a. Remove the pressure regulator adjustment cap and screw.
 - b. Using a screwdriver, turn the inner adjustment screw clockwise  to increase or counterclockwise  to decrease the main burner gas pressure.
 - c. Always replace the cap screw and tighten firmly to ensure proper operation.
4. If the desired outlet gas pressure or gas flow rate cannot be achieved by adjusting the gas control, check the gas control inlet pressure using a manometer at the inlet pressure tap. If the inlet pressure is in the normal range (refer to Table 5 or 6), replace the gas control. Otherwise, take the necessary steps to provide proper gas pressure to the gas control.

CHECK SAFETY SHUTDOWN PERFORMANCE

! WARNING

FIRE OR EXPLOSION HAZARD CAN CAUSE PROPERTY DAMAGE, SEVERE INJURY, OR DEATH

Perform the safety shutdown test any time work is done on a gas system.

NOTE: Read steps 1-7 below before starting and compare to the safety shutdown or safety lockout tests recommended for the intermittent pilot (IP) module. Where

TABLE 5—PRESSURE REGULATOR SPECIFICATION PRESSURES IN INCHES WC.

Model	Type of Gas	Nominal Inlet Pressure Range	Outlet Pressure			
			Nominal Factory Setting		Setting Range	
			Step	Full Rate	Step	Full Rate
Standard-, Slow-opening	Natural	5.0 - 7.0	—	3.5	—	3.0 - 5.0
	LP	12.0 - 14.0	—	10.0	—	8.0 - 12.0

TABLE 6—PRESSURE REGULATOR SPECIFICATION PRESSURES IN kPa.

Model	Type of Gas	Nominal Inlet Pressure Range	Outlet Pressure			
			Nominal Factory Setting		Setting Range	
			Step	Full Rate	Step	Full Rate
Standard-, Slow-opening	Natural	1.2 - 1.7	—	0.9	—	0.7 - 1.2
	LP	2.9 - 3.9	—	2.7	—	2.0 - 3.0

they differ, use the procedure recommended for the module.

1. Turn off gas supply.
2. Set thermostat or controller above room temperature and call for heat.
3. Watch for spark at pilot burner either immediately or following prepurge. See IP Module specifications.
4. If module has timed ignition, time length of spark operation. See IP Module specifications.
5. After the module locks out, open gas control knob and ensure there is no pilot or main burner gas flow. *With modules that continue spark until pilot lights or system is shut down manually, pilot should light when gas control knob is opened.*
6. Set thermostat below room temperature and wait one minute.
7. Operate system through one complete cycle to ensure all controls operate properly.

Maintenance



WARNING

FIRE OR EXPLOSION HAZARD CAN CAUSE PROPERTY DAMAGE, SEVERE INJURY, OR DEATH

Improper cleaning or reassembly may cause gas leakage. When cleaning, ensure that control is reassembled properly and perform gas leak test.

Regular preventive maintenance is important in applications that place a heavy load on system controls, such as in the commercial cooking and agricultural and industrial industries because:

- Equipment operates 100,000 to 200,000 cycles per year in many such applications, particularly commercial cooking. Such heavy cycling can wear out the gas control in one to two years.
- Exposure to water, dirt, chemicals and heat can damage the gas control and shut down the control system.

The maintenance program should include regular check-out of the gas control, see STARTUP AND CHECKOUT, page 5, and the control system as described in the appliance manufacturer's literature.

- Maintenance frequency must be determined individually for each application. Some considerations are:
- *Cycling frequency.* Appliances that may cycle 100,000 times annually should be checked monthly.

- *Intermittent use.* Appliances that are used seasonally should be checked before shutdown and again before the next use.
- *Consequence of unexpected shutdown.* Where the cost of an unexpected shutdown would be high, the system should be checked more often.
- *Dusty, wet, or corrosive environment.* Since these environments can cause the gas control to deteriorate more rapidly, the system should be checked more often.

The gas control should be replaced if:

- it does not perform properly on checkout or troubleshooting.
- the gas control knob is hard to turn or push down, or it fails to pop back up when released.
- the gas control is likely to have operated for more than 200,000 cycles.

Service



WARNING

FIRE OR EXPLOSION HAZARD CAN CAUSE PROPERTY DAMAGE, SEVERE INJURY OR DEATH

Do not disassemble the gas control; it contains non-replaceable components. Attempted disassembly or repair may damage the gas control.



CAUTION

Do not apply a jumper across or short the valve coil terminals. Doing so may burn out the heat anticipator in the thermostat or damage the electronic module.

IF MAIN BURNER WILL NOT COME ON WITH CALL FOR HEAT

1. Ensure the gas control knob is in the ON position.
2. Adjust the thermostat several degrees above room temperature.
3. Using ac voltmeter, check for 24V at gas control.
 - If pilot lights, measure across MV/PV and MV.
 - If pilot does not light, measure across MV/PV and PV before safety lockout occurs.
4. If voltage is incorrect or not present, check control circuit for proper operation.
5. If 24V is present, replace gas control.



WARNING

FIRE OR EXPLOSION HAZARD CAN CAUSE PROPERTY DAMAGE, SEVERE INJURY, OR DEATH



Follow these warnings exactly:

1. Pilot flame is lit automatically. Do not light the pilot flame manually.
2. Before lighting pilot burner flame, smell for gas around the appliance. Be sure to smell next to floor because LP gas is heavier than air.
3. IF YOU SMELL GAS:
 - Turn off the gas supply at the appliance service valve. On LP gas systems, turn off gas supply at the gas tank.
 - Do not light any appliances in the house.
 - Do not touch electrical switches or use the phone.
 - Leave the building and use a neighbor's phone to call your gas supplier.
 - If you can not reach your gas supplier, call the fire department.
4. Do not force the gas control knob. Use only your hand to push down or turn the gas control knob. Never use any tools. If the gas control knob will not operate by hand, the gas control should be replaced by a qualified service technician. Force or attempted repair may result in a fire or explosion.
5. The gas control must be replaced in case of any physical damage, tampering, bent terminals, missing or broken parts, stripped threads, or evidence of exposure to heat.

IMPORTANT: Follow the operating instructions provided by the manufacturer of your heating appliance. The information below will be of assistance in a typical gas control application, but the specific controls used and the procedures outlined by the manufacturer or your appliance may differ, requiring special instructions.

STOP: READ THE WARNINGS ABOVE.

The pilot flame is lit automatically. If the appliance does not turn on when the thermostat is set several degrees above room temperature, follow these instructions.

1. Set the thermostat to its lowest setting to reset the safety control.
2. Disconnect all electric power to the appliance.
3. Remove the gas control access panel.
4. Push in the gas control knob slightly and turn clockwise  to OFF.
5. Wait five minutes to clear out any unburned gas. If you then smell gas, STOP! Follow step 3 in the Warnings above. If you do not smell gas, continue with the next step.
6. Turn the gas control knob counterclockwise  to PILOT.
7. Turn the gas control knob counterclockwise  to ON.
8. Replace the gas control access panel.
9. Reconnect all electric power to the appliance.
10. Set the thermostat to the desired setting.
11. If the appliance does not turn on, set the gas control knob to OFF and contact a qualified service technician for assistance.

TURNING OFF THE APPLIANCE

VACATION SHUTDOWN—Set the thermostat to the desired room temperature while you are away.

COMPLETE SHUTDOWN—Push the gas control knob in slightly and turn clockwise  to OFF. Do not force. Appliance will completely shut off. Follow the Instructions to the Homeowner above to resume normal operation.

Honeywell

Helping You Control Your World

**Residential and
Building Controls Division**
Honeywell Inc.
1985 Douglas Drive North
Golden Valley, Minnesota 55422

**Residential and
Building Controls Division**
Honeywell Limited—Honeywell Limitée
740 Ellesmere Road
Scarborough, Ontario
M1P 2V9

