



P70, P72, and P170 Series Controls for Dual Pressure Applications

Product Bulletin

Code No. LIT-125455
 Issued August 30, 2012
 Supersedes September 1, 2000

Refer to the [QuickLIT Web site](#) for the most up-to-date version of this document.

The P70, P72, and P170 controls for dual pressure applications are designed primarily for use as combination high and low pressure controls on commercial refrigeration and air conditioning applications.

These controls are available in several pressure ranges and are compatible with most common refrigerants. Ammonia compatible models are also available.

These controls respond directly to system pressure changes on both high and low sides, and can provide single-device control of the compressor.

Controls are available in several different electrical ratings and switch configurations, including independent high and low pressure switches (on P70S and P170S models). The P72 models provide direct control of 208/240 volt, single-phase motors up to 3 horsepower, and 208/220 volt, 3-phase motors up to 5 horsepower.



Figure 1: P70SA-1 Dual Pressure Control

Table 1: Features and Benefits

Features	Benefits
All Steel Case and Cover	Provides long lasting, rugged protection for internal components.
Sight-Set Calibrated Pressure Adjustments	Provide visible pressure scales, fully adjustable through all ranges without removing the cover.
MICRO-SET® Differential Adjustment Option	Allows for narrow pressure control of low pressure applications
Independent High and Low Pressure Switches (P70S and P170S Models)	Satisfy a variety of dual pressure application wiring requirements with a single versatile control.
Convertible, High Pressure Reset–Auto Reset or Manual Reset Lockout (P70S and P170S Models)	Reduces inventory—one control can be adapted to several dual pressure applications in the field.

Applications

The P70, P72, and P170 controls for dual pressure applications provide combined high and low pressure control of compressors on commercial refrigeration and air conditioning applications.

IMPORTANT: Except for those models listed as refrigeration pressure limiting controls, use this P70, P72, and P170 Series Controls for Dual Pressure Applications only as an operating control. Where failure or malfunction of the P70, P72, or P170 Pressure Control could lead to personal injury or property damage to the controlled equipment or other property, additional precautions must be designed into the control system. Incorporate and maintain other devices, such as supervisory or alarm systems or safety or limit controls, intended to warn of or protect against failure or malfunction of the P70, P72, or P170 Pressure Control.

- P70S and P170S models have independently operated high and low pressure Single-Pole Double-Throw (SPDT) switches that can be wired to satisfy a variety of control requirements. These adaptable controls have a high pressure manual reset lockout mechanism that is convertible to automatic reset. See Table 2.
- P70L, M, N, and P170L, M, N models have a Single-Pole Single-Throw (SPST) switch. Models are available with automatic or manual reset lockout options. Models with manual reset are available with either high-side-only manual reset, or low-side **and** high-side manual reset. (See Table 2 and Table 3.) Ammonia compatible models are available (P70L and P70M only). See Table 4.
- P72 models have a Double-Pole Single-Throw (DPST) switch with load-carrying contacts that can provide direct control of 208/240 VAC, single-phase motors up to 3 hp, 480, and 600 VAC single-phase non-compressor motors and 208/220 VAC, 3-phase motors up to 5 hp. See Table 3.

These dual pressure controls are available in several pressure ranges and are compatible with most common refrigerants. Ammonia-compatible models are also available (P70L and P70M only). See Table 4.

The MICRO-SET® option provides fine adjustment of the differential setting for narrow pressure control of low pressure applications.

Some models feature Limited Knob Adjustment, which restricts adjustment of the pressure settings and deters over-adjustment or tampering.

A Manual Reset Lockout option does not allow the pressure control to reset automatically after CUT OUT is reached, and provides shutdown capability for unmonitored equipment.

NEMA 1 enclosures are standard on most models. A limited number of NEMA 3R enclosures are also available.

Table 2 through Table 4 list the standard models and features of P70, P72, and P170 controls for dual pressure applications. These standard models are available through most authorized Johnson Controls/PENN® distributors.

Operation

The high pressure and low pressure actuated bellows are connected to the controlled equipment by capillaries or field-installed flexible hoses (except on ammonia compatible models).

On most dual pressure control models, the two bellows are mechanically interconnected to operate a single switch. The switch is typically wired to provide control of the refrigeration or air conditioning compressor. On some models, the switch may also be wired to control alarms or other auxiliary devices.

On the P70S and P170S models, the high and low pressure bellows are not mechanically interconnected, and each bellows operates one of two SPDT switches independently.

Table 2: Standard Model P70, P72, and P170 MICRO-SET® Dual Pressure Controls for Non-Corrosive Refrigerants

Model Code Number	Switch Action	Low Pressure Side psig (kPa)		High Pressure Side psig (kPa)		Pressure Connector	Limited Knob Adjustment
		Range	Differential	Range	Differential (Non-Adjustable)		
P70LB-6¹	SPST	12 in. Hg–80 psig (-41–552)	Min 5 (34) Max 35 (241)	100–500 (690–3,447)	Fixed Approximately 65 (448)	36 in. Capillary with 1/4 in. Flare Nut	Low CUT OUT
P70MA-18¹					Lockout Requires Manual Reset		None
P70SA-1¹					Two Independent SPDT		Fixed at 65 (448) or Lockout Requires Manual Reset
P170LB-6¹	SPST				Fixed Approximately 65 (448)	1/4 in. Male Flare Connector	Low CUT OUT
P170MA-18¹					Lockout Requires Manual Reset		None
P170SA-1¹					Two Independent SPDT		Fixed at 65 (448) or Lockout Requires Manual Reset

1. Control models with high pressure side (only) that are UL Listed as Refrigeration Pressure Limiting Controls.

Table 3: Standard Model P70, P72, and P170 All Range Dual Pressure Controls for Non-Corrosive Refrigerants

Model Code Number	Switch Action	Low Pressure Side psig (kPa)		High Pressure Side psig (kPa)		Pressure Connector	Limited Knob Adjustment	
		Range	Differential	Range	Differential (Non-Adjustable)			
P70LB-1 ¹	SPST	20 in. Hg–100 psig (-68–690)	Min 6 (41) Max 50 (345)	100–500 (690–3,447)	Fixed Approximately 65 (448)	36 in. Capillary with 1/4 in. Flare Nut	Low CUT OUT	
P70MA-1 ¹							Lockout Requires Manual Reset	None
P70NA-1							Fixed (Manual Reset)	
P72LA-1 ¹	DPST		Min 7 (48) Max 50 (345)		Fixed Approximately 65 (448)		None	
P72LB-1 ¹								Low CUT OUT
P72MA-1 ¹							Lockout Requires Manual Reset	None
P72NA-1 ¹							Fixed (Manual Reset)	
P170LB-1 ¹	SPST		Min 7 (48) Max 50 (345)		Fixed Approximately 65 (448)	1/4 in. Male Flare Connector	Low CUT OUT	
P170MA-1 ¹							Lockout Requires Manual Reset	None
P170NA-1							Fixed (Manual Reset)	

1. Control models with high pressure side (only) that are UL Listed as Refrigeration Pressure Limiting Controls.

Table 4: Standard Model P70, P72, and P170 All Range Dual Pressure Controls for Ammonia

Model Code Number	Switch Action	Low Pressure Side psig (kPa)		High Pressure Side psig (kPa)		Pressure Connector	Limited Knob Adjustment
		Range	Differential	Range	Differential (Non-Adjustable)		
P70LA-2 ¹	SPST	20 in. Hg–100 psig (-68–690)	Min 7 (48) Max 50 (345)	100–500 (690–3,447)	Fixed Approximately 65 (448)	1/4 in. Female NPT Connector	None
P70MA-2 ¹							Lockout Requires Manual Reset

1. Control models with high pressure side (only) that are UL Listed as Refrigeration Pressure Limiting Controls.

Dimensions

See Figure 2 and Figure 3 for dimensional information.

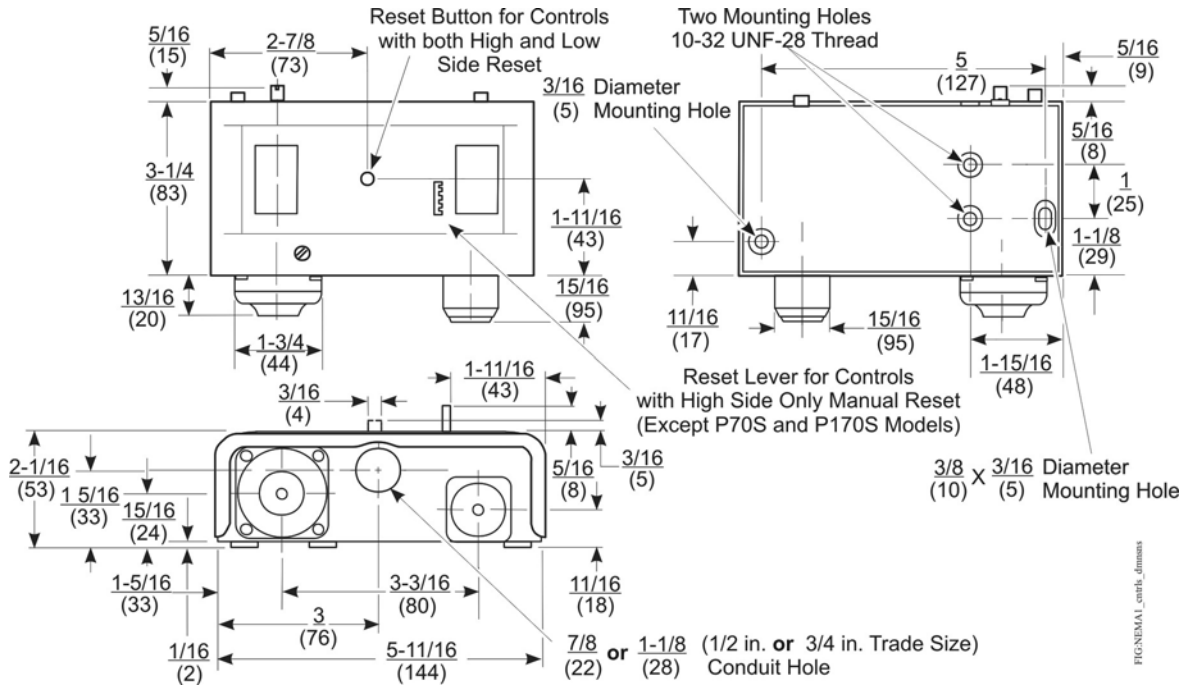

Figure 2: Dimensions for P70, P72, and P170 Dual Pressure Controls with NEMA 1 Enclosure, in. (mm)

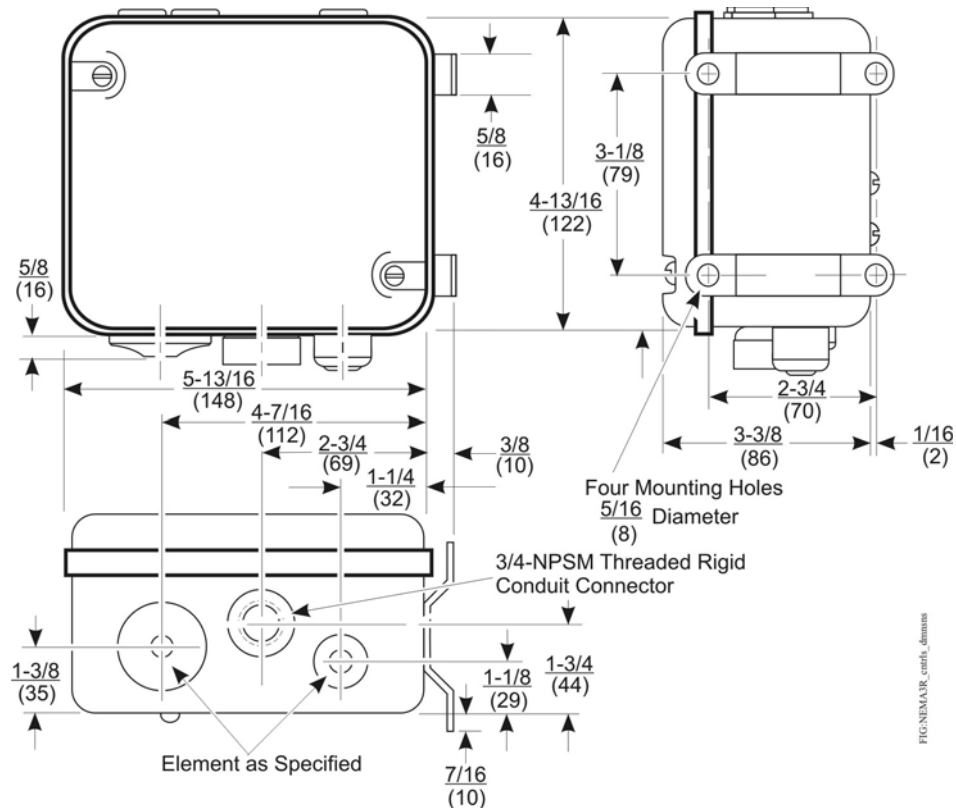

Figure 3: Dimensions for P70, P72, and P170 Dual Pressure Controls with NEMA 3R Enclosure, in. (mm)

Ordering Information

P70, P72, and P170 controls for dual pressure applications are available in a variety of standard and non-standard models. Table 1 is a model selection chart that lists the features on standard dual pressure control models available through most Johnson Controls/PENN Authorized Distributors.

Table 5 is a type identification matrix that itemizes all the potential P70, P72, and P170 dual pressure control types. Not all combinations in Table 5 are manufactured and available. Figure 4 illustrates the pressure connection styles available on P70, P72, and P170 control models.

Contact your Johnson Controls/PENN Authorized Representative for availability and price.

Table 5: Identification Matrix for P70, P72, and P170 Controls Dual Pressure Applications¹

P70	Various pressure connection styles available on many models	
P170	1/4 in. male flare pressure connection only (Style 5.)	
P72	DPST switch only, 3/4 in. conduit opening on most models, (P,Q, R, S, types not available)	
	L	SPST switch (except P72), automatic reset
	M	SPST switch (except P72), high side manual reset lockout switch
	N	SPST switch (except P72), high and low side manual reset lockout switch
	P	4-wire, 2-circuit switch, automatic reset
	Q	4-wire, 2-circuit switch, high side manual reset lockout switch
	R	4-wire, 2-circuit switch, high and low side manual reset lockout switch
	S	Two SPDT switches, convertible high side reset - auto/manual lockout
	A	NEMA 1 enclosure, no adjustment knob
	B	NEMA 1 enclosure, with adjustment knob
	C	No enclosure, no adjustment knob
	D	No enclosure, with adjustment knob
	E	NEMA 3R enclosure, no adjustment knob
	G	NEMA 3R enclosure, no adjustment knob, 1/2 in. conduit
	H	NEMA 1 enclosure, no adjustment knob, 1/4 in. quick connects
	J	NEMA 1 enclosure with adjustment knob, 1/4 in. quick connects
	N	NEMA 1 enclosure no adjustment knob, transportation application
	P	NEMA 1 enclosure with adjustment knob, transportation application
	S	NEMA 3R enclosure, no adjustment knob, transportation application

1. Not all combinations shown on this chart are available. To verify product availability and for quantity orders of non-standard items, please contact Refrigeration Application Engineering at 1-800-275-5676.

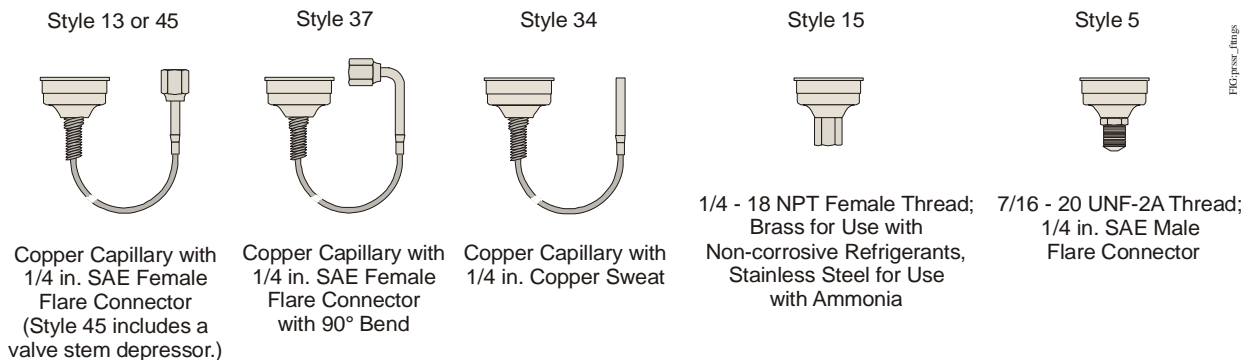

Figure 4: Available Pressure Fitting Styles

Repair Information

If the P70, P72, or P170 Control for Dual Pressure Applications fails to operate within its specifications, replace the unit. For a replacement P70, P72, or P170 control, contact the nearest Johnson Controls/PENN distributor or representative.

Technical Specifications

Table 6: SPST Electrical Ratings (P70L, M, N, and P170L, M, N Types)

	Standard Single-Phase Ratings					Hermetic Compressor 1Ø Ratings
	120 VAC	208 VAC	240 VAC	480 VAC ¹	600 VAC ¹	208/240 VAC
Motor Horsepower	1.5	3	3	--	--	--
Motor Full Load Amperes	20	18.7	17	5	4.8	20
Motor Locked Rotor Amperes	120	112.2	102	30	28.8	120
Non-Inductive Amperes	22	22	22	--	--	--
Pilot Duty	125 VA at 120 to 600 VAC; 57.5 VA at 120 to 300 VDC					

1. Not for compressor motor loads.

Table 7: 4-Wire 2-Circuit Electrical Ratings (P70P, Q, and R Types)

	Standard Single-Phase Ratings									
	Line-M2 (Main Contacts)						Line-M1 (Auxiliary Contacts)			
	120 VAC	208 VAC	240 VAC	277 VAC	480 VAC ¹	600 VAC ¹	120 VAC	208 VAC	240 VAC	277 VAC
Motor Full Load Amperes	16.0	9.2	8.0	--	5	4.8	6.0	3.3	3.0	--
Motor Locked Rotor Amperes	96.0	55.2	48.0	--	30	28.8	36.0	19.8	18.0	--
Non-Inductive Amperes	16.0	9.2	8.0	7.2	--	--	6.0	6.0	6.0	6.0
Pilot Duty (for both sets of contacts)	125 VA at 24 to 600 VAC; 57.5 VA at 120 to 300 VDC									

1. Not for compressor motor loads.

Table 8: SPDT Electrical Ratings (P70S and P170S Types, per switch)

	Standard Single-Phase Ratings			
	120 VAC	208 VAC	240 VAC	277 VAC
Motor Full Load Ampere	16.0	9.2	8.0	7.0
Motor Locked Rotor Ampere	96.0	55.2	48.0	42.0
Non-Inductive Ampere	16.0	9.2	8.0	7.0
Pilot Duty	125 VA at 24 VAC, 720 VA at 120 to 277 VAC			

Table 9: DPST Electrical Ratings (P72L, M, and N Types)

	Standard Ratings							Hermetic Compressor Ratings	
	120 VAC 1Ø	208 VAC 1Ø	240 VAC 1Ø	208 VAC 3Ø	220 VAC 3Ø	480 VAC 1Ø ¹	600 VAC 1Ø ¹	208 VAC 1Ø	240 VAC 1Ø
Motor Horsepower	2	3	3	5	5	--	--	--	--
Motor Full Load Amperes	24	18.7	17	15.9	15	5	4.8	24	24
Motor Locked Rotor Amperes	144	112.2	102	95.4	90	30	28.8	144	144
AC Non-Inductive Amperes	24	24	24	24	24	--	--	--	--
DC Non-Inductive Amperes	3	0.5	0.5	0.5	0.5	--	--	--	--
Pilot Duty	125 VA at 120 to 600 VAC; 57.5 VA at 120 to 300 VDC								

1. Not for compressor motor loads

P70, P72, and P170 Controls for Dual Pressure Applications (Part 1 of 2)

Switch Action	P70, P170: SPST or 4-Wire, 2-Circuit P70S, P170S: Two independent SPDT PENN® switches P72: DPST
Pressure Connection	P70, P72 Standard Models: various connections available (Styles 5, 13, 15, 34, 37) P170 Standard Models 1/4 in. male flare hose connection (Style 5) P70LA-2, P70MA-2 Ammonia-Compatible Models 1/4 in. female NPT connection (Style 15)
Maximum Overpressure (non-recurring)	Low Side All-Range: 325 psig (2,241 kPa) Low Side MICRO-SET®: 525 psig (3,620 kPa) High Side (All-Range and MICRO-SET®): 525 psig (3,620 kPa)
Maximum Working Pressure	Low Side All-Range: 100 psig (690 kPa) Low Side MICRO-SET®: 80 psig (552 kPa) High Side (All-Range and MICRO-SET®): 500 psig (3,447 kPa)
Ambient Conditions	-40 to 140°F (-40 to 60°C)
Case and Cover	NEMA 1 Enclosures: Galvanized steel case, plated and painted steel cover NEMA 3R Enclosures: Plated and painted steel case and cover

P70, P72, and P170 Controls for Dual Pressure Applications (Part 2 of 2)

Dimensions (H x W x D)	NEMA 1 Enclosure: 3-1/4 x 5-11/16 x 2-1/16 in. (83 x 144 x 53 mm) NEMA 3R Enclosure: 4-13/16 x 5-13/16 x 3-3/8 in. (122 x 148 x 86 mm)
Approximate Shipping Weight	NEMA 1 Enclosures Individual: 3.5 lb (1.6 kg) Bulk pack (25 controls): 75.5 lb (34.2 kg)
	NEMA3R Enclosures Individual: 4.7 lb (2.1 kg) Bulk pack (25 controls): 116.5 lb (52.9 kg)
Agency Listings	For information on specific models, contact Refrigeration Application Engineering at 1-800-275-5676.
Accessories	271-51 Universal Mounting Bracket (supplied with standard controls)

The performance specifications are nominal and conform to acceptable industry standards. For application at conditions beyond these specifications, contact Refrigeration Application Engineering at 1-800-275-5676. Johnson Controls, Inc. shall not be liable for damages resulting from misapplication or misuse of its products.



Building Efficiency

507 E. Michigan Street, Milwaukee, WI 53202

© Johnson Controls and PENN are registered trademarks of Johnson Controls, Inc. in the United States of America and/or other countries. All other trademarks used herein are the property of their respective owners. © Copyright 2012 by Johnson Controls, Inc. All rights reserved.