

Application

VB-7215 series single seat, stem up open, two-way valves control water from -7 to 138°C or steam to 138°C maximum in heating or air conditioning systems. They are used for two-position or proportional control applications. Valve assemblies require an actuator and a valve linkage that must be purchased separately.

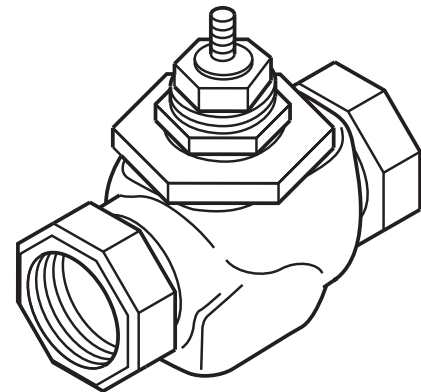

Danger: Do not use for combustible gas applications. The VB-7215 series valve packings are not rated for combustible gas applications, and if used in these applications, gas leaks and explosions could result.



Features

- Valve sizes 15 mm to 50 mm
- PN16 nominal pressure; also meets 250 psig pressure rating per ANSI Standards (B16.15–1985) for screwed cast bronze bodies
- Spring-loaded TFE packing
- End fittings Internal Parallel Pipe Thread per ISO 7/1, BS 21, JIS B0203

Applicable Literature

- Valve Products Catalog, F-27384
- Cross-Reference Guide, F-23638
- Reference Manual, F-21683
- Application Manual, F-21335
- Control Valve Sizing, F-13755
- Valve Selection Chart for Steam, F-11366
- Valve Selection Chart for Water, F-11080
- EN-205 Water System Guidelines, F-26080

SPECIFICATIONS

Table-1 Specifications/Models.

Specifications		Valve Body Series VB-7215-0-4-P
Service		Chilled or Hot Water and Steam
Flow Characteristics (Figure-1)		Equal Percentage
Action		Stem Up Open
Sizes		15 mm to 50 mm
Type of End Fitting		Internal Parallel Pipe Thread per ISO 7/1, BS 21, JIS B0203
Valve Materials	Body	Bronze
	Seat	Bronze
	Stem	Stainless Steel
	Plug	Brass
	Packing	Spring-loaded TFE
	Disc	EPDM
Pressure Class		PN16 (16 Bar) ^a
Maximum Inlet Pressure, Steam		241 kPa
Allowable Control Media Temperature		-7 to 138°C
Allowable Differential Pressure for Water^b		241 kPa Max. for Normal Life (refer to "Cavitation Limitations on Valve Pressure Drop" on page 7)
Allowable Differential Pressure for Steam^b		138 kPa
Valve Size in mm (R_p)^c	k_{vs} Rating^d	Complete Valve Body Part Number
15 (1/2)	0.3	VB-7215-0-4-1
	1.1	VB-7215-0-4-2
	1.9	VB-7215-0-4-3
	3.8	VB-7215-0-4-4
20 (3/4)	4.8	VB-7215-0-4-5
	6.5	VB-7215-0-4-6
25 (1)	8.7	VB-7215-0-4-7
	12	VB-7215-0-4-8
32 (1-1/4)	17	VB-7215-0-4-9
40 (1-1/2)	24	VB-7215-0-4-10
50 (2)	35	VB-7215-0-4-11

^a Also meets ANSI Class 250 (Figure-2).

^b Maximum recommended differential pressure in open position. Do not exceed recommended differential pressure (pressure drop) or integrity of parts may be affected. Exceeding maximum recommended differential pressure voids product warranty.

^c R_p = internal parallel pipe thread

^d $k_{vs} = m^3/h$ ($\Delta P = 100$ kPa) $C_v = k_{vs} \times 1.156$

Close-off Pressure Rating

The close-off pressure rating is dependent on the size of the valve, valve linkage, and actuator. Consult the **Valve Products Catalog, F-27384**, for close-off ratings.

Normal Position of Valve Assembly

For a valve assembly (valve, linkage, and actuator) to have a normal (spring return) position, the actuator must be of the spring return type. See Table-2 for spring return position of valve assemblies.

Table-2 Required Compatible Actuators/Linkages.

Actuator Series	Required Valve Linkage	Normal Position
MA-318, MA-418, MA-419	AV-391	N.O. or N.C.
MA-5210, MA-5211, MA-5213	AV-7600 ^a	Normally Open
MC-351, MC-431, MC-4311, MC5-4311	AV-393	None
MF-5413, MF-5513	AV-7600 ^a	Normally Open
MF-22203, MF-22303, MF-22323	Included w/Actuator	None
MF-63103, MF-63123		
MK-2690	AV-7400	Normally Open
MK-4601, MK-4611, MK-4621	AV-401	
MK-6601, MK-6611, MK-6621	—	
MM-400, MMR-400	AV-630 or AV-630-010	None
MM-500, MMR-500		N.O. or N.C.
MP-361, MP-367, MP-465, MP5-361, MP5-4651	AV-391	Normally Closed
MP-371, MP-377, MP-475, MP5-371, MP5-4751		Normally Open
MP-381, MP-382, MP-387, MP-485, MP-486, MP-4851, MP5-4851	AV-393	None
MP-5210, MP-5211, MP-5213	AV-7600 ^a	Normally Open
MP-5410, MP-5411, MP-5413	AV-7600 & AV-601	
MP-5511, MP-5513		
MPR-5610, MPR-5611, MPR-5613	AV-7600 & AV-601	Normally Open
MPR-5713		
MS-22353	Included w/Actuator	None

^a High ambient temperatures with high media temperatures in the valve may require the use of AV-601 in addition to AV-7600. See General Instructions for AV-7600 (F-26235) and AV-601 (F-19069) for details.

Flow Characteristics

All valves have modified equal percentage flow characteristics. That is, for equal increments of valve stem stroke, the change in flow rate with respect to valve stroke may be expressed as a constant percent of the flow rate at the time of the change. The change of flow rate with respect to valve stroke is relatively small when the valve plug is near the valve seat and relatively high when the valve plug is nearly wide open. See Figure-1 for typical modified equal percentage flow characteristics of VB-7215 series valve bodies.

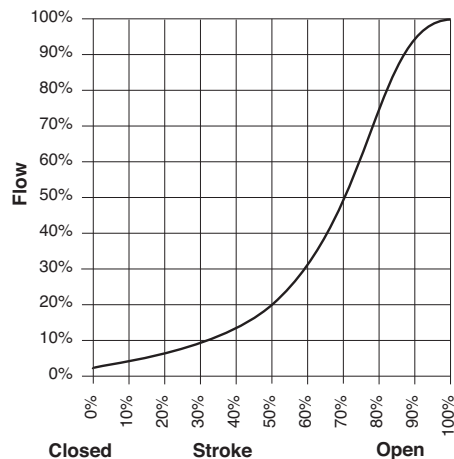

Figure-1 Typical Modified Equal Percentage Flow Characteristics.

Rangeability

Rangeability is the ratio of rated flow to the minimum controllable flow through a valve. Table-3 lists the rangeability for VB-7215 series valves.

Table-3 Rangeability.

Valve Body Part Number	Nominal Rangeability	Valve Body Part Number	Nominal Rangeability
VB-7215-0-4-1	5:1	VB-7215-0-4-7	60:1
VB-7215-0-4-2	15:1	VB-7215-0-4-8	75:1
VB-7215-0-4-3	25:1	VB-7215-0-4-9	75:1
VB-7215-0-4-4	40:1	VB-7215-0-4-10	75:1
VB-7215-0-4-5	50:1	VB-7215-0-4-11	75:1
VB-7215-0-4-6	60:1		

Temperature/Pressure Ratings

See Figure-2 for temperature and pressure ratings. Consult the appropriate valve linkage general instruction sheet for the effect of valve body ambient temperatures on specific actuators. Ratings conform with published values and disclaimer.

VB-7215-0-4-P (Screwed Cast Bronze Body)

Standards: Pressure to ANSI B16.15 Class 250 with 2758 kPa up to 65°C decreasing to 2218 kPa at 138°C

Materials: Bronze, ASTM B584

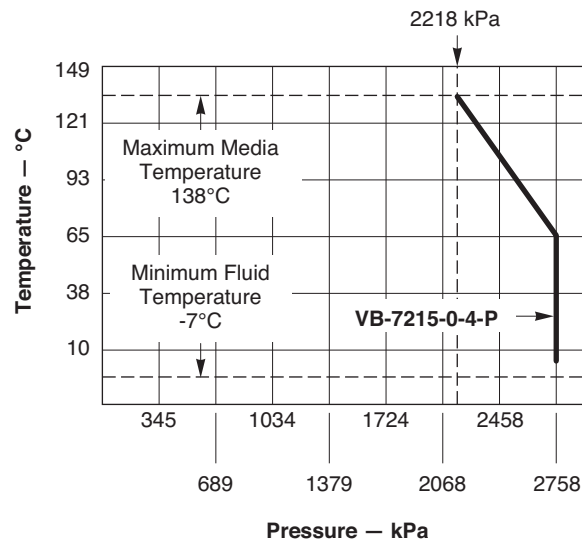

Figure-2 Temperature and Pressure Ratings for VB-7215 Series Valve Bodies.

VALVE SIZING AND SELECTION

Water

Two-position

Two-position control valves are normally selected “line size” to keep pressure drop at a minimum. If it is desirable to reduce the valve below line size, then 10% of “available pressure” (that is, the pump pressure differential available between supply and return mains with design flow at the valve location) is normally used to select the valve.

Proportional

Proportional control valves are usually selected to take a pressure drop equal to at least 50% of the “available pressure.” As “available pressure” is often difficult to calculate, the normal procedure is to select the valve using a pressure drop at least equal to the drop in the coil or other load being controlled (except where small booster pumps are used) with a minimum recommended pressure drop of 34 kPa. When the design temperature drop is less than 33°C for conventional heating systems, higher pressure drops across the valve are needed for good results (Table-4).

Table-4 Conventional Heating System.

Design Temperature Load Drop (°C)	Recommended Pressure Drop ^a (% of Available Pressure)	Multiplier on Load Drop
33 or More	50%	1 x Load Drop
22	66%	2 x Load Drop
11	75%	3 x Load Drop

^a Recommended minimum pressure drop = 34 kPa.

Secondary Circuits with Small Booster Pumps: 50% of available pressure difference (equal to the drop through load, or 50% of booster pump head).

Water Capacity

See Table-5 for water capacity of VB-7215 series valves.

Table-5 Water Capacity in Litres Per Second (L/s) for VB-7215 Series.

Valve Body Part Number	k _{vs} Rating	Differential Pressure (ΔP in kPa) ^a												
		10	20	30	40	50	60	70	80	90	100	150	200	241
VB-7215-0-4-1	0.3	0.03	0.04	0.05	0.06	0.07	0.07	0.08	0.09	0.09	0.10	0.12	0.14	0.15
VB-7215-0-4-2	1.1	0.10	0.14	0.17	0.20	0.22	0.24	0.26	0.28	0.30	0.31	0.38	0.44	0.48
VB-7215-0-4-3	1.9	0.17	0.24	0.29	0.33	0.37	0.41	0.44	0.47	0.50	0.53	0.65	0.75	0.82
VB-7215-0-4-4	3.8	0.33	0.47	0.58	0.67	0.75	0.82	0.88	0.95	1.0	1.1	1.3	1.5	1.6
VB-7215-0-4-5	4.8	0.42	0.59	0.72	0.84	0.93	1.0	1.1	1.18	1.3	1.3	1.6	1.9	2.1
VB-7215-0-4-6	6.5	0.57	0.81	0.99	1.1	1.3	1.4	1.5	1.61	1.7	1.8	2.2	2.5	2.8
VB-7215-0-4-7	8.7	0.76	1.07	1.3	1.5	1.7	1.9	2.0	2.15	2.3	2.4	2.9	3.4	3.7
VB-7215-0-4-8	12	1.1	1.5	1.8	2.1	2.4	2.6	2.8	3.0	3.2	3.4	4.1	4.8	5.2
VB-7215-0-4-9	17	1.5	2.1	2.6	3.0	3.3	3.7	4.0	4.2	4.5	4.7	5.8	6.7	7.3
VB-7215-0-4-10	24	2.1	3.0	3.7	4.3	4.8	5.2	5.6	6.0	6.4	6.7	8.2	9.5	10.4
VB-7215-0-4-11	35	3.0	4.3	5.3	6.1	6.8	7.4	8.0	8.6	9.1	9.6	11.8	13.6	14.9

^a Bar = kPa/100 kg/cm² = kPa x 0.01019 m³/h = L/s x (3600/1000)

k_{vs} Equation

$$Q = k_{vs} \cdot \sqrt{\Delta P} \quad \Delta P = \left(\frac{Q}{k_{vs}} \right)^2 \quad k_{vs} = \frac{Q}{\sqrt{\Delta P}}$$

Where:

Q = Flow in cubic metres per hour (m³/h)

k_{vs} = Flow in cubic metres per hour at a 1 Bar (100 kPa) pressure drop (ΔP)

ΔP = Differential pressure in Bar (pressure drop)

Steam

Two-position

Two-position zone valves and direct radiation valves are normally sized using a minimum of 10% of inlet pressure (psig).

Proportional

Proportional control valves are normally sized using:

- For low pressure (100 kPa or less), use ΔP of 80% of gauge inlet pressure.
- For steam pressures greater than 100 kPa, use ΔP of 42% of absolute (gauge plus 101.3 kPa) inlet pressure.
- When the k_{vs} required is between two valve sizes, select the larger size. Do not size steam valves using a pressure drop greater than 42% of the absolute inlet pressure.

Steam Capacity

See Table-6 for steam capacity of VB-7215 series valves.

Table-6 Steam Capacity in Kilograms Per Hour (kg/h) for VB-7215 Series.

Valve Body Part Number	k_{vs} Rating	Differential Pressure (ΔP in kPa) ^a															
		15 kPa Inlet		35 kPa Inlet		50 kPa Inlet		75 kPa Inlet		100 kPa Inlet		150 kPa Inlet		200 kPa Inlet		241 kPa Inlet	
		1.5	12	3.5	28	5	40	7.5	60	10	80	15	105	20	126	24	143
VB-7215-0-4-1	0.3	0.9	2.3	1.4	3.6	1.8	4.4	2.3	5.5	2.9	6.4	3.9	8.1	4.9	9.7	5.7	11
VB-7215-0-4-2	1.1	3.1	8.5	5.2	13	6.5	16	8.5	20	10	24	14	26	18	31	21	35
VB-7215-0-4-3	1.9	5.4	15	9	23	11	28	15	35	18	41	25	51	31	62	36	70
VB-7215-0-4-4	3.8	11	29	18	46	22	55	29	69	36	82	49	103	62	123	73	140
VB-7215-0-4-5	4.8	14	37	23	58	28	70	37	87	46	103	62	129	78	154	92	175
VB-7215-0-4-6	6.5	19	50	31	78	38	95	50	118	62	140	84	175	106	210	124	239
VB-7215-0-4-7	8.7	25	67	41	104	51	127	67	158	83	187	113	234	142	280	166	318
VB-7215-0-4-8	12	34	93	56	144	71	175	93	219	114	258	156	327	196	392	229	446
VB-7215-0-4-9	17	49	131	80	204	100	247	132	310	162	365	221	459	278	551	325	626
VB-7215-0-4-10	24	69	185	113	288	142	349	186	437	229	515	311	654	392	785	458	891
VB-7215-0-4-11	35	100	270	164	420	206	509	271	637	334	752	454	946	572	1134	668	1288

^a Values are for saturated steam ($K = 1$). Left column under each inlet pressure is for two-position control, and right column is for proportional control.

k_{vs} Equation

$$Q = \frac{0.218 \cdot k_{vs} \cdot \sqrt{(\Delta P \cdot P_2)}}{K} \quad k_{vs} = \frac{QK}{0.218 \cdot k_{vs} \cdot \sqrt{(\Delta P \cdot P_2)}}$$

Where:

Q = Steam flow in kilograms per hour (kg/h)

k_{vs} = Coefficient of flow

ΔP = Differential pressure (pressure drop) in kPa

P_2 = Outlet pressure in kPa (absolute) (P_2 = Inlet gauge pressure in kPa + 101.3 – ΔP)

K = 1 + (0.0026 • °C superheat) (K = 1 for saturated steam)

Cavitation Limitations on Valve Pressure Drop

A valve selected with too high a pressure drop can cause erosion of discs and/or wire drawing of the seat. In addition, cavitation can cause noise, damage to the valve trim (and possibly the body), and choke the flow through the valve.

Do not exceed the maximum differential pressure (pressure drop) for the valve selected.

The following formula can be used on higher temperature water systems, where cavitation could be a problem, to estimate the maximum allowable pressure drop across the valve:

$$P_m = 0.5 (P_1 - P_v)$$

Where:

P_m = Maximum allowable pressure drop (kPa)

P_1 = Absolute inlet pressure (kPa)

P_v = Absolute vapor pressure (kPa) (refer to Table-6 or Table-7)

Note: Add 101.3 kPa to gauge supply pressure to obtain absolute pressure value.

For example, if a valve is controlling 94°C water at an inlet pressure of 125 kPa, the maximum pressure drop allowable would be:

$$P_m = 0.5 [(125 + 101.3) - 81] = 72 \text{ kPa}$$

(Vapor pressure of 94°C water is 81 kPa.)

If the pressure drop for this valve is less than 72 kPa, cavitation should not be a problem.

Systems where cavitation is shown to be a problem can sometimes be redesigned to provide lower inlet velocities. Valves having harder seat materials should be furnished if inlet velocities cannot be lowered.

Table-7 Vapor Pressure of Water Table.

Water Temp. (°C)	Vapor Pressure (kPa)	Water Temp. (°C)	Vapor Pressure (kPa)	Water Temp. (°C)	Vapor Pressure (kPa)	Water Temp. (°C)	Vapor Pressure (kPa)
4	0.81	34	5.3	64	24	94	81
10	1.2	40	7.4	70	31	100	101
16	1.8	46	10	76	40	106	125
22	2.6	52	14	82	51	112	153
28	3.8	58	18	88	65	116	175

Additional Valve Sizing Information

For additional valve sizing information, see:

- CA-28 Control Valve Sizing, F-13755
- Valve Selection Chart Water, F-11080
- Valve Selection Chart Steam, F-11366
- Valve Sizing Slide Rule, TOOL-150

INSTALLATION

Inspection

Inspect the package for damage. If damaged, notify the appropriate carrier immediately. If undamaged, open the package and inspect the device for obvious damage. Return damaged products.

Requirements

- Tools (not provided): Pipe wrenches
- Training: Installer must be a qualified, experienced technician
- Appropriate accessories

Caution:

- Install the valve with the flow in the direction of the flow arrow (“A” port is the inlet and “AB” port is the outlet).
 - Do not exceed the ratings of the device.
 - Avoid locations where excessive moisture, corrosive fumes, or vibration are present.
-

Mounting

1. The valve should be mounted in a weather-protected area in a location that is within the ambient limits of the actuator. When selecting a location, allow sufficient room for valve linkage, actuator, and other accessories and for service of the product.
2. The preferred mounting position for the valve is with the valve stem vertical above the valve body. Avoid mounting the valve so that the valve stem is below horizontal.
3. On steam applications where the ambient temperature approaches the limit of the actuator, the valve stem should be mounted 45° from vertical.
4. The valves must be piped with the “A” port as the inlet and the “AB” port as the outlet.

Screwed Valve Bodies

The VB-7215-0-4 series screwed valve bodies conform to ISO 7/1, BS 21, JIS B0203, Internal Parallel Pipe Thread (R_p).

1. Apply pipe dope sparingly to all but the last two threads of a properly threaded, reamed, and cleaned pipe. Make sure that pipe chips, scale, etc. do not get into the pipe since this material may lodge in the valve seat and prevent proper closing and opening of the valve.
2. Start the joint by hand screwing the pipe into the valve. If the thread engagement feels “right,” turn the pipe by hand as far as it will go.
3. Use a pipe wrench to fully tighten the valve to the pipe. Do not over tighten or strip threads. See Table-8 and Figure-3 for the normal engagement length of the threads. Figure-4 shows a means of tightening the pipe so that the valve is not twisted or crushed.

Table-8 Normal Thread Engagement Between Male Pipe Thread and Valve Body.

Valve Size in mm (R _p)	Normal Engagement in mm	Valve Size in mm (R _p)	Normal Engagement in mm
15 (1/2)	13	32 (1-1/4)	17
20 (3/4)	14	40 (1-1/2)	17
25 (1)	17	50 (2)	19

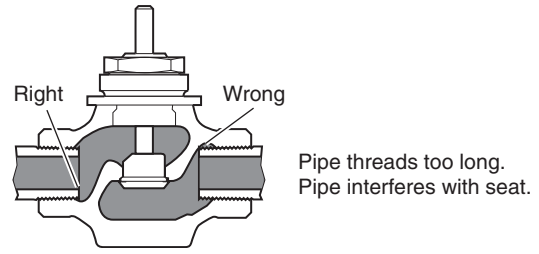

Figure-3 Normal Thread Engagement.

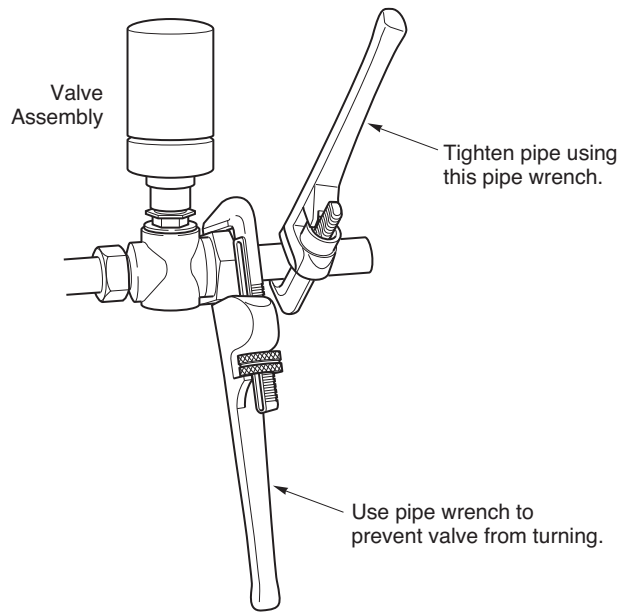

Figure-4 Installation of Screwed End Valves.

CHECKOUT

1. Make sure the valve stem operates smoothly before installing the valve linkage and the actuator.
2. If the stem does not operate smoothly, it may indicate that the valve was twisted or crushed during installation or that the stem was bent by rough handling. These conditions may require that the valve be replaced.
3. After the piping is under pressure, check the valve body and the connections for leaks.
4. After the valve linkage and the actuator are installed, check their operation.
 - a. Power the actuator and run the valve to the stem down position. Make sure the linkage and valve stem move freely. At the stem down position, the valve should shut off tightly.
 - b. For spring return actuators, allow the actuator to spring return to the stem up position. Again, the valve stem and linkage should operate smoothly. At the stem up position, the valve should be in its full open position.

MAINTENANCE & FIELD REPAIR

Regular maintenance of the total system is recommended to assure sustained performance. See Table-9 for maintenance kit part numbers.

Table-9 Maintenance Kits for VB-7215 Valves

Valve Body Part Number	Replacement Packing Assembly	Packing Wrench	Valve Repair Kit ^a
VB-7215-0-4-1	YBA-622-1	TOOL-20-1	RYB-721-1
VB-7215-0-4-2			RYB-721-2
VB-7215-0-4-3			RYB-721-3
VB-7215-0-4-4			RYB-721-4
VB-7215-0-4-5			RYB-721-5
VB-7215-0-4-6			RYB-721-6
VB-7215-0-4-7			RYB-721-7
VB-7215-0-4-8			RYB-721-8
VB-7215-0-4-9			RYB-721-9
VB-7215-0-4-10			RYB-721-10
VB-7215-0-4-11			RYB-721-11

^a Kit includes replacement packing and stem & plug assembly.

Water System Maintenance

All heating and cooling systems are susceptible to valve and system problems caused by improper water treatment and system storage procedures. These guidelines are provided to help avoid valve and water system problems resulting from improperly treated water or storage procedures in cooling and hot water systems, and to obtain maximum life from Schneider Electric valves.

Durability of valve stems and packings is dependent on maintaining non-damaging water conditions. Inadequate water treatment or filtration, not in accordance with chemical supplier/ASHRAE handbook recommendations, can result in corrosion, scale, and abrasive particle formation. Scale and particulates can result in stem and packing scratches and can adversely affect packing life and other parts of the hydronic system.

To maintain non-damaging conditions, follow these guidelines:

- Clean the system prior to start up. Use a nitrite or molybdate-based treatment program.
- Use filtration equipment where needed.
- Properly store off-line systems and monitor water treatment results using corrosion test coupons.
- Follow the advice of a water treatment professional.
- Consult **EN-205, Water System Guidelines Engineering Information, F-26080**, for further details.

DIMENSIONAL DATA

Table-10 Dimensions for VB-7215 Series Valve (Figure-5).

Part Number	Valve Size in mm (R _p)	Dimensions in mm				
		A	B	C	D (Stem Down)	E ^a (Stroke)
VB-7215-0-4-1 VB-7215-0-4-2 VB-7215-0-4-3 VB-7215-0-4-4	15 (1/2)	78	27	43	19	11
VB-7215-0-4-5 VB-7215-0-4-6	20 (3/4)	92				
VB-7215-0-4-7 VB-7215-0-4-8	25 (1)	118	29	60		
VB-7215-0-4-9	32 (1-1/4)		35			
VB-7215-0-4-10	40 (1-1/2)	137	38	57		
VB-7215-0-4-11	50 (2)	156	40	70		

^a Stroke for rated flow; add up to 1.6 mm for disc seating and compression.

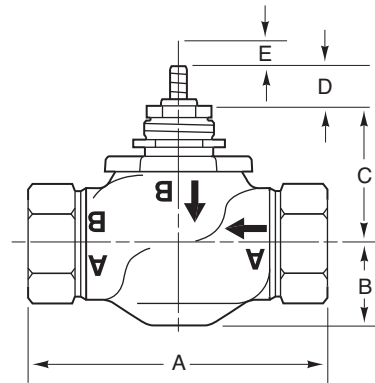

Figure-5 Typical of VB-7215-0-4-P Valve Bodies.

On October 1st, 2009, TAC became the Buildings business of its parent company Schneider Electric. This document reflects the visual identity of Schneider Electric, however there remains references to TAC as a corporate brand in the body copy. As each document is updated, the body copy will be changed to reflect appropriate corporate brand changes.

Copyright 2010, Schneider Electric
All brand names, trademarks and registered
trademarks are the property of their respective
owners. Information contained within this
document is subject to change without notice.

Schneider Electric
1354 Clifford Avenue
P.O. Box 2940
Loves Park, IL 61132-2940

www.schneider-electric.com/buildings

