

A/C Compressor Product Guide

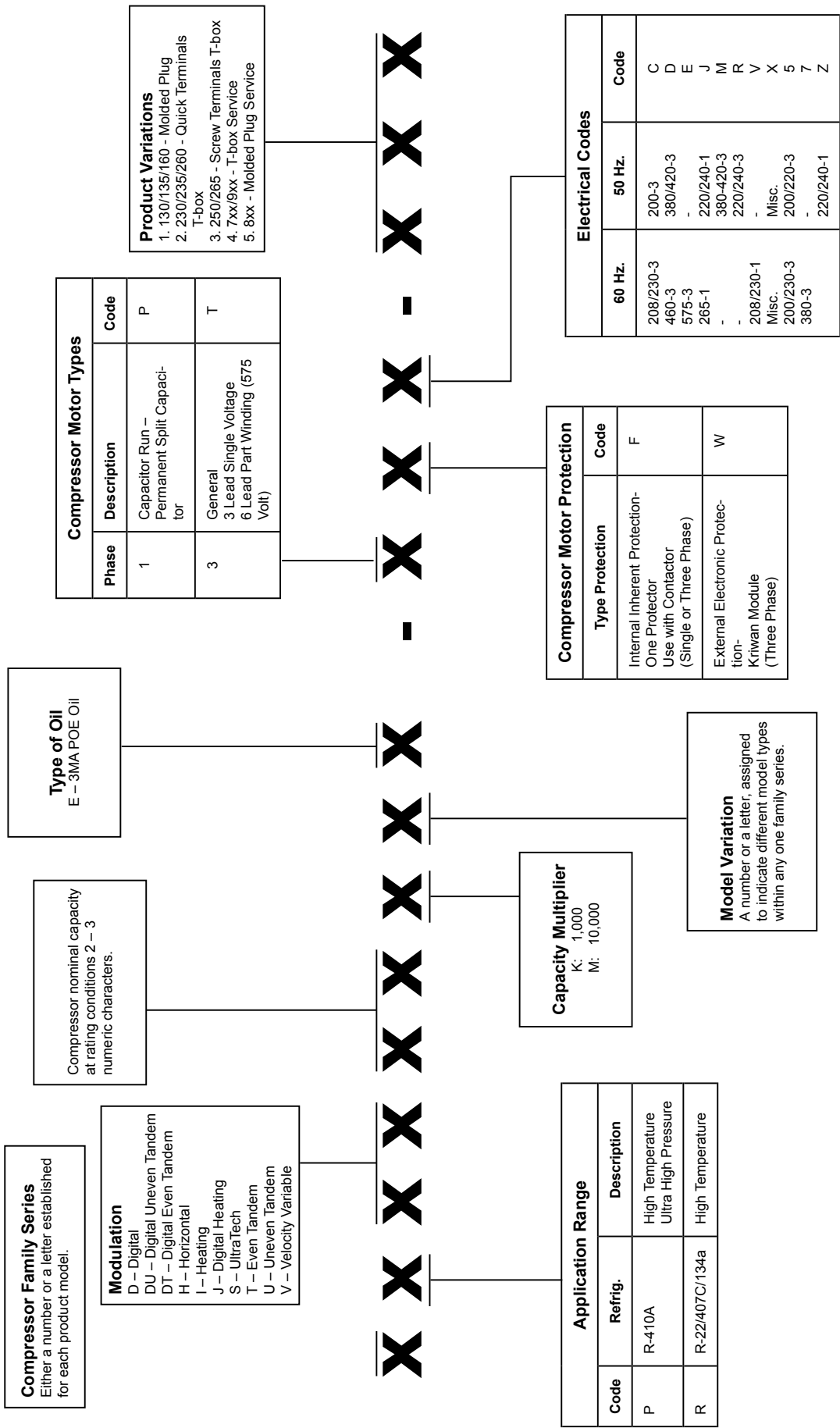

NOMENCLATURE • A/C SCROLL MODELS



NOMENCLATURE • CR7, CR6, CRKF MODELS

Compressor Family Series
 Either a number or a letter established for each product model.

Compressor nominal capacity at rating conditions to two significant digits.

Indicates compressors with polyol ester oil.

Compressor Motor Types		
Phase	Description	Code
1	Capacitor Run – Permanent Split Capacitor	P
3	Three Phase General – 3 Lead Single Voltage 6 Lead Part Winding (575 Volt)	T

Product Variations
 Numbers will be assigned as follows:

- Number –230 indicates a standard compressor B/M and model number.
- Number –270 indicates a standard compressor B/M with crankcase heater.
- Number –500 series indicates international standard compressor B/M and model number.
- Number –730 indicates a standard OEM service B/M and model number.
- Number –700 and –900 series indicate standard OEM and Wholesaler service B/M and model number.
- For B/M different from –230, –270, and –730, contact Emerson Climate Technologies, Inc. Sales and Service.

XXXXXXE-XXXX-XXXX

Application Range		
Code	Refrig.	Description
R	R-22	High Temp. A/C & Heat Pump
S	R-404A	Med. Temp. Refrigeration
F	R-404A	Low Temp. Refrigeration

Model Variation
 A number or letter, assigned to indicate different model types within any one family series.

Capacity Multiplier
 K = 1000

Electrical Codes		
60 Hz.	50 Hz.	Code
208/230-3	200/220-3	C
460-3	380/420-3	D
575-3	500-3	E
265-1	220/240-1	J
-	380/420-3	M
208/230-1	200-1	V
-	220/240-1	Z
-	360/460-3	1*
-	180/260-1	2*
200/230-3	200/240-3	5

Compressor Motor Protection	
Type Protection	Code
Internal Inherent Protection – One Protector (Single or three phase)	F

* Wide voltage range for India produced products

NOMENCLATURE • CRKQ, CIKQ MODELS

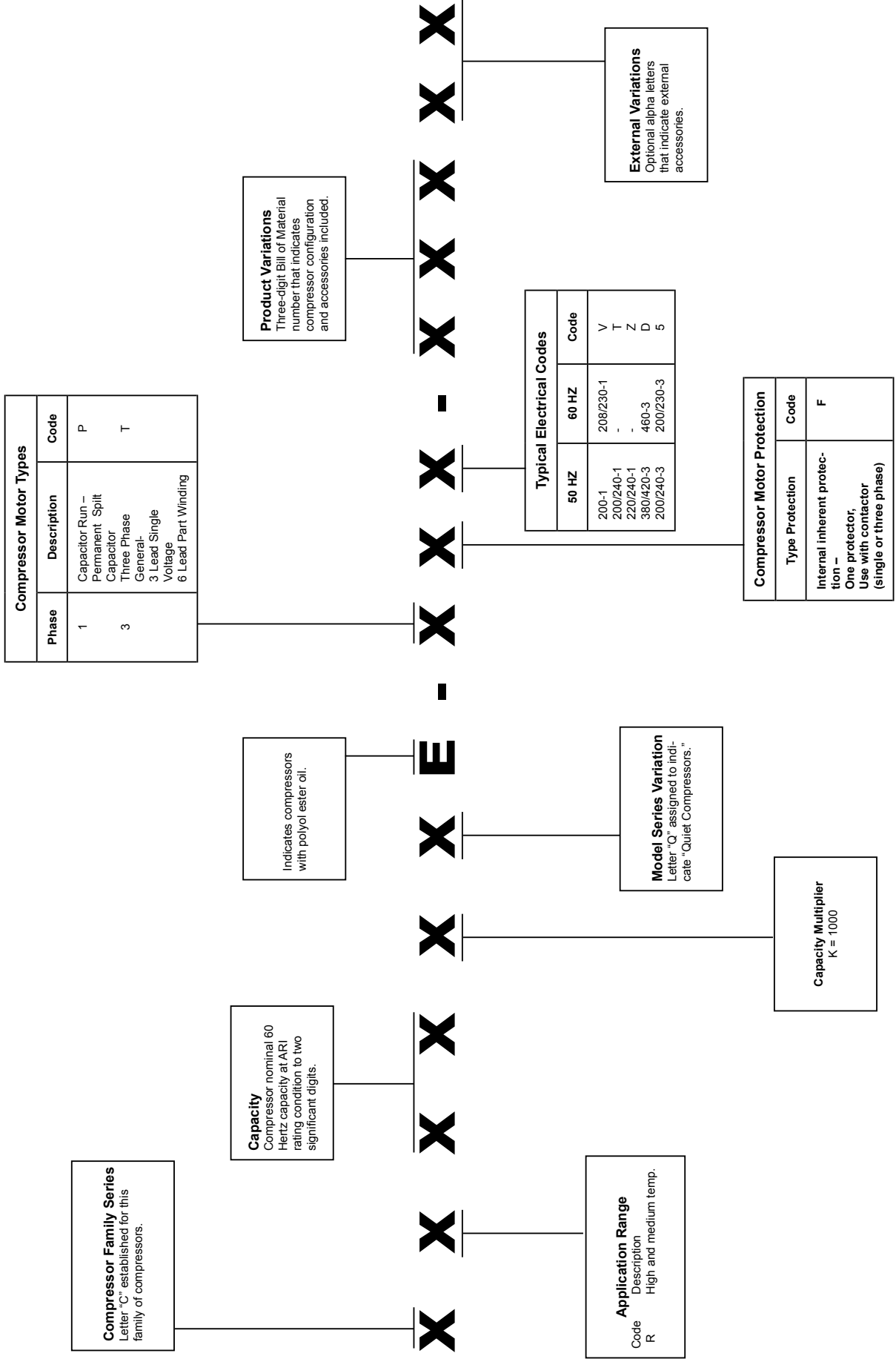

Copeland® Compressor Model Number

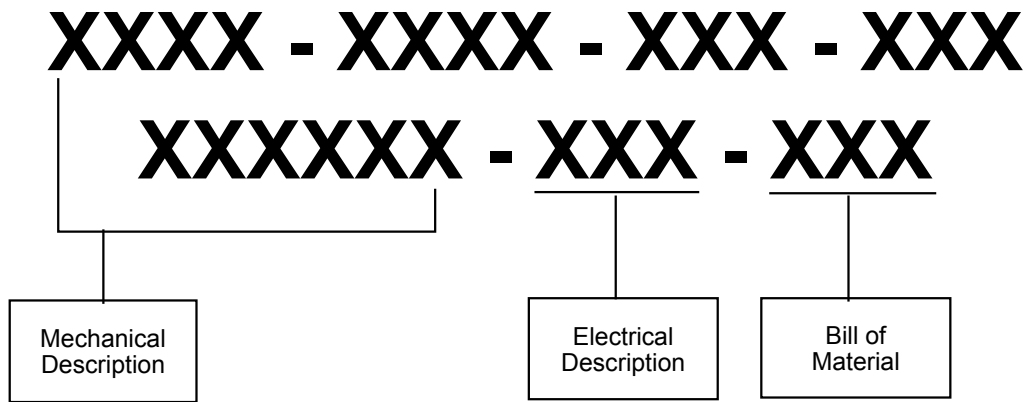

Copeland® Compressor Serial Number

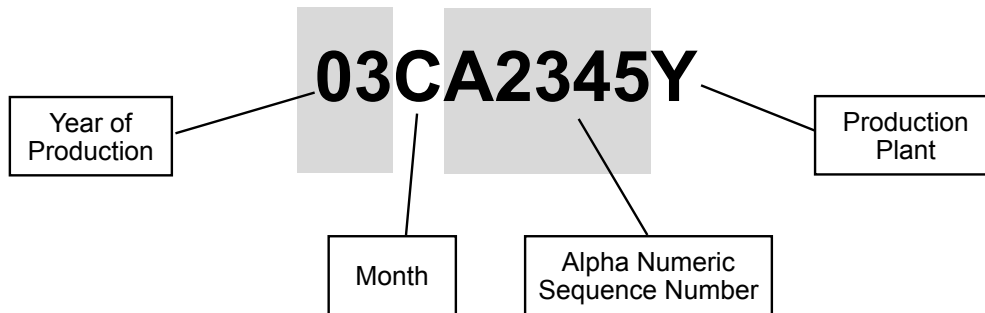

Recommended Run Capacitors for Field Replacement of a ZR* K1 or K2 with a ZR* K3, K4, or KC

	K1	*K2	K3	K4	KC
ZR18	25µf/370 volt		30µf/370 volt	35µf/370 volt	30µf/370 volt
ZR23	30µf/370 volt		40µf/370 volt	35µf/370 volt	35µf/370 volt
ZR26	35µf/370 volt		40µf/370 volt		30µf/440 volt
ZR28	35µf/370 volt		45µf/370 volt		35µf/440 volt
ZR34	35µf/440 volt		50µf/370 volt		40µf/370 volt
ZR40	35µf/440 volt		55µf/370 volt		40µf/440 volt
ZR46		40µf/440 volt	60µf/370 volt		
ZR49		40µf/440 volt	60µf/370 volt		45µf/440 volt
ZR57		55µf/440 volt	80µf/370 volt		60µf/370 volt
ZR61		55µf/440 volt	80µf/370 volt		60µf/370 volt

Compressor Refrigerant Charge Limits

Model	Frame Size *	Three Phase Charge Limit **		Single Phase Charge Limit **	
		Lbs	kg	Lbs	kg
ZR16-ZR29KC	53	6	2.7	7.2	3.24
ZR16-ZR24K4	53	6	2.7	7.2	3.24
ZR26-ZR48KC	63	8	3.6	9.6	4.32
ZR18-ZR48K3	63	8	3.6	9.6	4.32
ZR54-ZR81KC	70	10	4.5	12.0	5.40
ZR54-ZR61K3	70	10	4.5	12.0	5.40
ZR16-ZR34KA	53	8	3.6	9.6	4.32
ZR38-ZR54KA	63	10	4.5	12.0	5.40
TANDEM	63	10	4.5	12.0	5.40
TANDEM	70	12	5.5	14.4	6.60

*Approximate Shell Diameter (e.g. 63 = 6.5 Inches)

**Charge Allowance for System

Crankcase Heaters, 1.5-7.5 Tons

Copeland® Model	Watts	Volts	Lead Length (in.)	ZRK4	ZRKA	ZRK5	ZRK3	ZRKC	ZRDKC	ZRSK4	ZPK5	ZPK3	ZPKC	ZPSK4	ZPK5
018-0094-01	40	120	21.25	ZR16-24K4	ZR16-34KA	ZR16-32K5					ZP16-31K5				
018-0096-01	40	120	29.25		ZR38-54KA	ZR38-54K5	ZR18-48K3	ZR26-48KC		ZRS43-52K4	ZP34-54K5	ZP16-44K3		ZPS20-40K4	
018-0095-07	70	120	48.25				ZR18-61K3	ZR26-81KC	ZRD36-48KC	ZRS43-52K4		ZP16-57K3	ZP61-91KC	ZPS20-60K4	ZPD34-54K5
018-0094-00	40	240	21.25	ZR16-24K4	ZR16-34KA	ZR16-32K5					ZP16-31K5				
018-0096-00	40	240	29.25		ZR38-54KA	ZR38-54K5	ZR18-48K3	ZR26-48KC		ZRS43-52K4	ZP34-54K5	ZP16-44K3		ZPS20-40K4	
018-0096-04	40	240	48.25		ZR38-54KA	ZR38-54K5	ZR18-48K3	ZR26-48KC		ZRS43-52K4	ZP34-54K5	ZP16-44K3		ZPS20-40K4	
018-0096-06	40	240	31.75		ZR38-54KA	ZR38-54K5					ZP34-54K5				
018-0095-00	70	240	29.25				ZR18-61K3	ZR26-81KC		ZRS43-52K4		ZP16-57K3	ZP61-91KC	ZPS20-60K4	
018-0095-03	70	240	29.25				ZR18-61K3	ZR26-81KC		ZRS43-52K4		ZP16-57K3	ZP61-91KC	ZPS20-60K4	
018-0095-04	70	240	48.25				ZR18-61K3	ZR26-81KC	ZRD36-48KC	ZRS43-52K4		ZP16-57K3	ZP61-91KC	ZPS20-60K4	ZPD34-54K5
018-0094-02	40	277	21.25		ZR16-34KA	ZR16-32K5					ZP16-31K5				
018-0095-09	70	277	29.25				ZR18-61K3	ZR26-81KC		ZRS43-52K4		ZP16-57K3	ZP61-91KC	ZPS20-60K4	
018-0095-08	70	400	48.25				ZR18-61K3	ZR26-81KC		ZRS43-52K4		ZP16-57K3	ZP61-91KC	ZPS20-60K4	
018-0094-03	40	480	21.25		ZR16-34KA	ZR16-32K5					ZP16-31K5				
018-0096-02	40	480	29.25		ZR38-54KA	ZR38-54K5	ZR18-48K3	ZR26-48KC		ZRS43-52K4	ZP34-54K5	ZP16-44K3		ZPS20-40K4	
018-0096-05	40	480	48.25		ZR38-54KA	ZR38-54K5	ZR18-48K3	ZR26-48KC		ZRS43-52K4	ZP34-54K5	ZP16-44K3		ZPS20-40K4	
018-0095-01	70	480	29.25				ZR18-61K3	ZR26-81KC		ZRS43-52K4		ZP16-57K3	ZP61-91KC	ZPS20-60K4	
018-0095-05	70	480	48.25				ZR18-61K3	ZR26-81KC	ZRD36-48KC	ZRS43-52K4		ZP16-57K3	ZP61-91KC	ZPS20-60K4	ZPD34-54K5
018-0094-04	40	575	21.25		ZR16-34KA	ZR16-32K5					ZP16-31K5				
018-0096-03	40	575	29.25		ZR38-54KA	ZR38-54K5	ZR18-48K3	ZR26-48KC		ZRS43-52K4	ZP34-54K5	ZP16-44K3		ZPS20-40K4	
018-0095-02	70	575	29.25				ZR18-61K3	ZR26-81KC		ZRS43-52K4		ZP16-57K3	ZP61-91KC	ZPS20-60K4	
018-0095-06	70	575	48.25				ZR18-61K3	ZR26-81KC		ZRS43-52K4		ZP16-57K3	ZP61-91KC	ZPS20-60K4	

ZR Single Phase Compressors

Model	Ref	Cap (BTU)	Volts	Hz	Ph	LRA	RLA (MCC/1.4)	MFD	Volts
ZR18K3-PFV	22	18,100	208/230	60	1	47	9.3	30	370
ZR22K3-PFV	22	22,400	208/230	60	1	56	11.4	45	370
ZR24K3-PFV	22	24,500	208/230	60	1	61	13.6	40	370
ZR26K3-PFV	22	26,600	208/230	60	1	67	13.6	40	370
ZR28K3-PFV	22	28,500	208/230	60	1	72.5	15	45	370
ZR30K3-PFV	22	31,100	208/230	60	1	73	15	45	370
ZR32K3-PFV	22	32,600	208/230	60	1	83	16.4	45	370
ZR34K3-PFV	22	34,400	208/230	60	1	88	17.9	50	370
ZR36K3-PFV	22	36,900	208/230	60	1	95	18.4	50	370
ZR40K3-PFV	22	40,600	208/230	60	1	104	20	55	370
ZR42K3-PFV	22	42,800	208/230	60	1	109	20.4	60	370
ZR45K3-PFV	22	46,000	208/230	60	1	137	23.6	60	440
ZR46K3-PFV	22	47,000	208/230	60	1	129	26.4	60	370
ZR47K3-PFV	22	48,200	208/230	60	1	137	21.4	60	440
ZR48K3-PFV	22	49,800	208/230	60	1	137	22.1	60	440
ZR49K3-PFV	22	49,200	208/230	60	1	129	26.4	60	370
ZR52K3-PFV	22	52,000	208/230	60	1	148	27.9	80	370
ZR54K3-PFV	22	55,000	208/230	60	1	148	27.9	80	370
ZR57K3-PFV	22	58,000	208/230	60	1	148	32.1	80	370
ZR61K3-PFV	22	62,000	208/230	60	1	148	32.1	80	370

ZR Three Phase Compressors

Model	Ref	Cap (BTU)	Volts	Hz	Ph	LRA	RLA (MCC/1.4)
ZR22K3-TF5	22	22,100	200/230	60	3	45	7.9
ZR22K3-TFD	22	22,100	460	60	3	22.4	3.9
ZR24K3-TF5	22	24,800	200/230	60	3	55	8.6
ZR24K3-TFD	22	24,800	460	60	3	27	4.3
ZR26K3-TF5	22	26,500	200/230	60	3	55	8.6
ZR26K3-TFD	22	26,200	460	60	3	27	4.3
ZR28K3-TF5	22	28,900	200/230	60	3	63	10
ZR28K3-TFD	22	28,900	460	60	3	31	5
ZR30K3-TF5	22	31,100	200/230	60	3	63	10.7
ZR30K3-TFD	22	31,100	460	60	3	31	5
ZR32K3-TF5	22	32,600	200/230	60	3	77	10.7
ZR32K3-TFD	22	32,600	460	60	3	35	5.4
ZR34K3-TF5	22	34,000	200/230	60	3	77	11.4
ZR34K3-TFD	22	34,000	460	60	3	39	5.7
ZR36K3-TF5	22	36,900	200/230	60	3	77	11.4
ZR36K3-TFD	22	36,900	460	60	3	39	5.7
ZR40K3-TF5	22	40,600	200/230	60	3	88	13.9
ZR40K3-TFD	22	40,600	460	60	3	44	6.4
ZR42K3-TF5	22	42,800	200/230	60	3	88	13.9
ZR42K3-TFD	22	42,800	460	60	3	44	7.1
ZR45K3-TF5	22	45,600	200/230	60	3	91	15.4
ZR45K3-TFD	22	45,600	460	60	3	46	7.9
ZR46K3-TF5	22	46,100	200/230	60	3	120	15
ZR46K3-TFD	22	46,100	460	60	3	49.5	8.2
ZR47K3-TF5	22	47,500	200/230	60	3	91	16.4
ZR47K3-TFD	22	47,500	460	60	3	50	7.9

ZR Three Phase Compressors (cont.)

Model	Ref	Cap (BTU)	Volts	Hz	Ph	LRA	RLA (MCC/1.4)
ZR48K3-TF5	22	49,100	200/230	60	3	91	16.4
ZR48K3-TFD	22	48,900	460	60	3	50	7.9
ZR49K3-TF5	22	49,200	200/230	60	3	120	15
ZR49K3-TFD	22	49,200	460	60	3	49.5	8.2
ZR52K3-TF5	22	52,000	200/230	60	3	128	17.1
ZR52K3-TFD	22	52,000	460	60	3	49.5	7.5
ZR54K3-TF5	22	54,200	200/230	60	3	123	19.3
ZR54K3-TFD	22	54,500	460	60	3	49.5	7.5
ZR57K3-TF5	22	58,500	200/230	60	3	123	19.3
ZR57K3-TFD	22	58,500	460	60	3	62	9.1
ZR61K3-TF5	22	62,000	200/230	60	3	137	19.3
ZR61K3-TFD	22	62,000	460	60	3	62	9.1
ZR84KC-TF5	22	85,500	200/230	60	3	196	28.6
ZR84KC-TFD	22	85,500	460	60	3	100	14.3
ZR94KC-TF5	22	96,500	200/230	60	3	195	32.1
ZR94KC-TFD	22	96,500	460	60	3	95	16.4
ZR108KC-TF5	22	109,000	200/230	60	3	225	33.6
ZR108KC-TFD	22	109,000	460	60	3	114	17.3
ZR125KC-TF5	22	128,000	200/230	60	3	239	41.4
ZR125KC-TFD	22	128,000	460	60	3	125	19.2
ZR144KC-TF5	22	146,000	200/230	60	3	245	47.1
ZR144KC-TFD	22	146,000	460	60	3	125	20.7
ZR160KC-TFD	22	160,000	460	60	3	150	25
ZR160KC-TW5	22	160,000	200/230	60	3	300	53.6
ZR160KC-TWD	22	160,000	460	60	3	150	24.3
ZR190KC-TFD	22	190,000	460	60	3	179	27.9
ZR190KC-TW5	22	190,000	200/230	60	3	340	58.6
ZR190KC-TWD	22	190,000	460	60	3	173	28.6

LCS Three Phase Compressors

Model	Ref	Cap (BTU)	Volts	Hz	Ph	LRA	RLA (MCC/1.4)
ZR250KC-TW5	22	250,000	200/230	60	3	505	81.4
ZR250KC-TWC	22	250,000	208/230	60	3	505	81.4
ZR250KC-TWD	22	250,000	460	60	3	225	33.6
ZR250KCE-TW5	22	250,000	200/230	60	3	505	81.4
ZR250KCE-TWC	22	250,000	208/230	60	3	505	81.4
ZR250KCE-TWD	22	250,000	460	60	3	225	33.6
ZR300KC-TW5	22	296,000	200/230	60	3	500	87.9
ZR300KC-TWC	22	296,000	208/230	60	3	500	87.9
ZR300KC-TWD	22	296,000	460	60	3	250	42.9
ZR310KC-TWC	22	306,000	208/230	60	3	605	93.6
ZR310KC-TWD	22	306,000	460	60	3	272	41.4
ZR380KC-TW5	22	379,000	200/230	60	3	599	111.4
ZR380KC-TWC	22	379,000	208/230	60	3	599	111.4
ZR380KC-TWD	22	379,000	460	60	3	310	54.3

ZP Single Phase Compressors

Model	Ref	Cap (BTU)	Volts	Hz	Ph	LRA	RLA (MCC/1.4)	MFD	Volts
ZP16K3E-PFV	410A	15,500	208/230	60	1	51	11.4	40	370
ZP16K5E-PFV	410A	15,500	208/230	60	1	48	10	30	370
ZP20K3E-PFV	410A	20,300	208/230	60	1	60	14.3	35	370
ZP20K5E-PFV	410A	20,000	208/230	60	1	58.3	15	35	370
ZP21K5E-PFV	410A	21,300	208/230	60	1	58.3	14.3	40	370
ZP23K3E-PFV	410A	23,500	208/230	60	1	61	15	40	370
ZP24K5E-PFV	410A	24,000	208/230	60	1	64	14.3	40	370
ZP25K5E-PFV	410A	25,200	208/230	60	1	73	15.7	40	370
ZP26K3E-PFV	410A	25,700	208/230	60	1	72.5	16.4	45	370
ZP28K5E-PFV	410A	27,900	208/230	60	1	77	17.9	45	370
ZP29K5E-PFV	410A	29,000	208/230	60	1	77	15.7	45	370
ZP31K5E-PFV	410A	31,100	208/230	60	1	79	18.6	45	370
ZP32K3E-PFV	410A	31,300	208/230	60	1	83	17.1	45	370
ZP34K5E-PFV	410A	34,500	208/230	60	1	112	20	45	370
ZP36K3E-PFV	410A	36,200	208/230	60	1	105	20.7	55	370
ZP36K5E-PFV	410A	36,000	208/230	60	1	112	20	45	370
ZP38K3E-PFV	410A	37,800	208/230	60	1	104	21.4	55	370
ZP38K5E-PFV	410A	37,500	208/230	60	1	109	22.1	45	370
ZP39K5E-PFV	410A	39,000	208/230	60	1	109	22.1	45	370
ZP41K3E-PFV	410A	41,000	208/230	60	1	109	22.9	60	370
ZP42K5E-PFV	410A	42,000	208/230	60	1	117	24.3	70	370
ZP44K3E-PFV	410A	44,300	208/230	60	1	134	25.7	60	370
ZP50K3E-PFV	410A	50,500	208/230	60	1	145	30	80	370
ZP51K5E-PFV	410A	51,000	208/230	60	1	134	29.4	70	370
ZP54K3E-PFV	410A	54,500	208/230	60	1	158	30.7	80	370
ZP54K5E-PFV	410A	54,000	208/230	60	1	134	29.3	80	370
ZP57K3E-PFV	410A	57,000	208/230	60	1	158	33.6	80	370

ZP Three Phase Compressors

Model	Ref	Cap (BTU)	Volts	Hz	Ph	LRA	RLA (MCC/1.4)
ZP20K3E-TF5	410A	20,200	200/230	60	3	55	8.6
ZP20K3E-TFD	410A	19,900	460	60	3	22.4	4.4
ZP23K3E-TF5	410A	23,400	200/230	60	3	63	9.3
ZP23K3E-TFD	410A	23,400	460	60	3	27	5
ZP24K5E-TF5	410A	24,000	200/230	60	3	58	9.3
ZP24K5E-TFD	410A	24,000	460	60	3	28	5.7
ZP25K5E-TF5	410A	25,200	200/230	60	3	58	9.9
ZP25K5E-TFD	410A	25,200	460	60	3	28	4.6
ZP26K3E-TF5	410A	25,500	200/230	60	3	63	11.6
ZP28K5E-TF5	410A	27,900	200/230	60	3	71	11.1
ZP29K5E-TF5	410A	29,000	200/230	60	3	71	10
ZP29K5E-TFD	410A	29,000	460	60	3	38	6.3
ZP31K5E-TF5	410A	31,200	200/230	60	3	73	11.6
ZP31K5E-TFD	410A	31,200	460	60	3	38	6.4
ZP32K3E-TF5	410A	31,800	200/230	60	3	77	12.9
ZP32K3E-TFD	410A	30,500	460	60	3	35	5.7
ZP34K5E-TF5	410A	34,600	200/230	60	3	88	14.7
ZP34K5E-TFD	410A	34,600	460	60	3	44	6.6
ZP36K3E-TF5	410A	36,200	200/230	60	3	88	15
ZP36K3E-TFD	410A	35,600	460	60	3	39	7.1
ZP36K5E-TF5	410A	36,000	200/230	60	3	88	15.1
ZP36K5E-TFD	410A	36,000	460	60	3	44	6.6
ZP38K3E-TF5	410A	37,600	200/230	60	3	88	15
ZP38K3E-TFD	410A	37,600	460	60	3	46	7.9
ZP38K5E-TF5	410A	38,100	200/230	60	3	83.1	15.1
ZP38K5E-TFD	410A	38,100	460	60	3	41	6.8
ZP39K5E-TF5	410A	39,000	200/230	60	3	83.1	14.6
ZP39K5E-TFD	410A	39,000	460	60	3	41	6.8
ZP41K3E-TF5	410A	41,200	200/230	60	3	91	16.2
ZP41K3E-TFD	410A	40,700	460	60	3	46	7.9
ZP42K5E-TF5	410A	41,900	200/230	60	3	83.1	15.3
ZP42K5E-TFD	410A	41,900	460	60	3	41	6.9
ZP44K3E-TF5	410A	44,300	200/230	60	3	91	17.9
ZP44K3E-TFD	410A	44,300	460	60	3	46	7.9
ZP50K3E-TF5	410A	51,500	200/230	60	3	123	19.6
ZP50K3E-TFD	410A	51,500	460	60	3	62	10.7
ZP51K5E-TF5	410A	51,500	200/230	60	3	110	17.8
ZP51K5E-TFD	410A	51,500	460	60	3	52	8.6
ZP54K3E-TF5	410A	54,500	200/230	60	3	137	20.2
ZP54K3E-TFD	410A	54,400	460	60	3	62	10
ZP54K5E-TF5	410A	54,300	200/230	60	3	110	17.4
ZP54K5E-TFD	410A	54,300	460	60	3	52	8.6
ZP57K3E-TF5	410A	58,000	200/230	60	3	155	22.9
ZP57K3E-TFD	410A	58,000	460	60	3	75	10.7
ZP61KCE-TF5	410A	61,500	200/230	60	3	123	21.2
ZP61KCE-TFD	410A	61,500	460	60	3	62	10.9

ZP Three Phase Compressors

Model	Ref	Cap (BTU)	Volts	Hz	Ph	LRA	RLA (MCC/1.4)
ZP67KCE-TF5	410A	67,500	200/230	60	3	149	25
ZP67KCE-TFD	410A	67,000	460	60	3	75	11.8
ZP72KCE-TF5	410A	72,000	200/230	60	3	164	25.9
ZP72KCE-TFD	410A	72,000	460	60	3	75	12.5
ZP83KCE-TF5	410A	83,000	200/230	60	3	164	27.9
ZP83KCE-TFD	410A	83,000	460	60	3	100	13.6
ZP90KCE-TF5	410A	90,500	200/230	60	3	195	32.9
ZP90KCE-TFD	410A	90,500	460	60	3	95	16.4
ZP103KCE-TF5	410A	105,000	200/230	60	3	225	33.6
ZP103KCE-TFD	410A	105,000	460	60	3	114	18.6
ZP120KCE-TF5	410A	123,000	200/230	60	3	239	37.1
ZP120KCE-TFD	410A	123,000	460	60	3	125	20
ZP137KCE-TF5	410A	137,000	200/230	60	3	245	53.6
ZP137KCE-TFD	410A	135,000	460	60	3	125	20.7
ZP154KCE-TFD	410A	155,000	460	60	3	150	25
ZP154KCE-TW5	410A	155,000	200/230	60	3	300	57.1
ZP154KCE-TWD	410A	155,000	460	60	3	150	25.7
ZP180KCE-TWC	410A	180,000	208/230	60	3	425	59.1
ZP180KCE-TWD	410A	180,000	460	60	3	187	26.4
ZP181KCE-TWD	410A	178,000	460	60	3	110	26.4
ZP182KCE-TFD	410A	183,000	460	60	3	179	29.3
ZP182KCE-TW5	410A	183,000	200/230	60	3	340	62.1
ZP182KCE-TWD	410A	183,000	460	60	3	173	30
ZP235KCE-TWC	410A	235,000	208/230	60	3	505	82.4
ZP235KCE-TWD	410A	235,000	460	60	3	225	33.9
ZP285KCE-TW5	410A	278,000	200/230	60	3	500	99.3
ZP285KCE-TWC	410A	278,000	208/230	60	3	500	99.3
ZP285KCE-TWD	410A	278,000	460	60	3	250	47.9
ZP295KCE-TWC	410A	294,000	208/230	60	3	605	95
ZP295KCE-TWD	410A	294,000	460	60	3	272	46.7
ZP385KCE-TW5	410A	385,000	200/230	60	3	599	122.1
ZP385KCE-TWC	410A	385,000	208/230	60	3	599	122.1
ZP385KCE-TWD	410A	385,000	460	60	3	310	60.7

CR Single Phase Compressors

Model	Ref	Cap (BTU)	Volts	Hz	Ph	LRA	RLA (MCC/1.4)	MFD	Volts
CR14K7-PFV	22	14,100	208/230	60	1	35	6.9	35	370
CR16K6-PFV	22	16,300	208/230	60	1	49	9.6	25	370
CR16K7-PFV	22	16,200	208/230	60	1	39	8.4	35	370
CR16KQ-PFV	22	15,700	208/230	60	1	38	7.9	25	440
CR18K6-PFV	22	18,000	208/230	60	1	49	10.4	25	370
CR18K7-PFV	22	17,500	208/230	60	1	40	8.6	35	370
CR18KQ-PFV	22	18,400	208/230	60	1	41	9	30	440
CR19K7-PFV	22	19,300	208/230	60	1	43	10.2	30	370
CR20K6-PFV	22	19,600	208/230	60	1	50	10.6	30	370
CR20KQ-PFV	22	19,800	208/230	60	1	54	10.4	30	370
CR21K7-PFV	22	21,000	208/230	60	1	51	11.3	30	370
CR22K6-PFV	22	22,100	208/230	60	1	50	10.9	30	370
CR22KQ-PFV	22	21,800	208/230	60	1	51.5	11.1	35	440
CR23K7-PFV	22	22,600	208/230	60	1	49	10.8	40	370
CR24K6-PFV	22	24,500	208/230	60	1	61	12.4	35	370
CR24K7-PFV	22	24,300	208/230	60	1	60	12	40	370
CR24KQ-PFV	22	23,900	208/230	60	1	70.5	13.6	35	440
CR26K6-PFV	22	26,200	208/230	60	1	76.1	13.6	35	370
CR28K6-PFV	22	28,200	208/230	60	1	75	15.3	35	370
CR28K7-PFV	22	28,300	208/230	60	1	73	13.6	35	440
CR28KQ-PFV	22	27,300	208/230	60	1	70.5	15	35	440
CR30K6-PFV	22	30,000	208/230	60	1	82	16	35	370
CR30KQ-PFV	22	29,500	208/230	60	1	78	15.4	35	440
CR30KQE-PFV	22	29,400	208/230	60	1	78	15.4	35	440
CR31K7-PFV	22	30,700	208/230	60	1	82	16.1	35	440
CR32K6-PFV	22	32,000	208/230	60	1	82	16.1	35	440
CR33KQ-PFV	22	32,700	208/230	60	1	75	16	40	440
CR34K6-PFV	22	34,500	208/230	60	1	96	16.6	50	370
CR34KQ-PFV	22	34,000	208/230	60	1	84	16.7	40	440
CR35K6-PFV	22	35,000	208/230	60	1	96	18	40	370
CR35K7-PFV	22	35,300	208/230	60	1	89	18.2	35	440
CR36KQ-PFV	22	36,300	208/230	60	1	93	17.6	40	440
CR37KQ-PFV	22	36,800	208/230	60	1	100	18.6	40	370
CR38K6-PFV	22	38,200	208/230	60	1	105	19	40	440
CR41KQ-PFV	22	41,700	208/230	60	1	109.6	19.4	50	440
CR42K6-PFV	22	41,900	208/230	60	1	102	20.4	40	440
CR47KQ-PFV	22	47,500	208/230	60	1	132	24.6	45	440
CR53KQ-PFV	22	53,300	208/230	60	1	140	28.9	60	440

CR Three Phase Compressors

Model	Ref	Cap (BTU)	Volts	Hz	Ph	LRA	RLA (MCC/1.4)
CR18KQ-TF5	22	18,400	200/230	60	3	49	6.1
CR22K6-TF5	22	22,000	200/230	60	3	51	7.5
CR24K6-TF5	22	24,000	200/230	60	3	55	7.7
CR24KQ-TF5	22	23,300	200/230	60	3	51	7.5
CR28K6-TF5	22	28,100	200/230	60	3	68	10
CR28K6-TFD	22	28,100	460	60	3	34	4.8
CR28K7-TF5	22	27,700	200/230	60	3	65.5	10
CR28KQ-TF5	22	27,300	200/230	60	3	60.5	8.9
CR30K6-TF5	22	29,800	200/230	60	3	65.5	10.4
CR30K6-TFD	22	29,800	460	60	3	33	4.9
CR31K7-TF5	22	30,000	200/230	60	3	66	9.1
CR32K6-TF5	22	31,900	200/230	60	3	70	10
CR32K6-TFD	22	31,900	460	60	3	33	5.1
CR32KQ-TF5	22	31,400	200/230	60	3	63	9.9
CR33KQ-TF5	22	32,000	200/230	60	3	69	10.6
CR33KQ-TFD	22	32,000	460	60	3	31.6	4.7
CR34KQ-TF5	22	33,900	200/230	60	3	67	11.8
CR34KQ-TFD	22	33,500	460	60	3	29.2	5.4
CR35K6-TF5	22	34,900	200/230	60	3	75	11.4
CR35K6-TFD	22	34,900	460	60	3	40	4.8
CR36KQ-TF5	22	35,200	200/230	60	3	68	12.4
CR36KQ-TFD	22	35,700	460	60	3	34.5	5.5
CR37KQ-TF5	22	36,400	200/230	60	3	85	11.1
CR38K6-TF5	22	37,900	200/230	60	3	85	11.9
CR41KQ-TF5	22	40,700	200/230	60	3	80	13.1
CR42K6-TF5	22	41,700	200/230	60	3	91	14
CR42K6-TFD	22	41,700	460	60	3	42	6.4
CR47KQ-TF5	22	47,200	200/230	60	3	97	16.1
CR53KQ-TF5	22	53,200	200/230	60	3	107	18.2

Commercial Scroll Protection Module

Obsolete Part #	Replacement Part #	Service Replacement Kit #	Voltage	Notes
071-0615-01	071-0649-01	998-0520-04	24v	ZR250/300 ZP235/285
071-0615-00	071-0649-00	998-0520-00	115v/230v	ZR250/300 ZP235/285
071-0620-00	071-0650-00	971-0547-01	115v/230v	3 Phase Loss protection
NA	071-0641-01	971-0641-01	24v	ZR160/190 ZP154/182
NA	071-0641-00	971-0641-00	115v/230v	ZR160/190 ZP154/182

Stub Tube to Rotalock

Stub Tube I.D.	Thread Size	Non-Stick Seal	Adapter Kit*
3/8"	1" - 14	020-0028-00	998-0034-14
1/2"	1" - 14	020-0028-00	998-0034-15
5/8"	1" - 14	020-0028-00	998-0034-16
3/4"	1-1/4" - 12	020-0028-02	998-0034-01
7/8"	1-1/4" - 12	020-0028-02	998-0034-02
1-1/8"	1-3/4" - 12	020-0025-03	998-0034-03
1-3/8"	1-3/4" - 12	020-0028-03	998-0034-04
1-5/8"	2-1/4" - 12	020-0941-00	998-0034-06

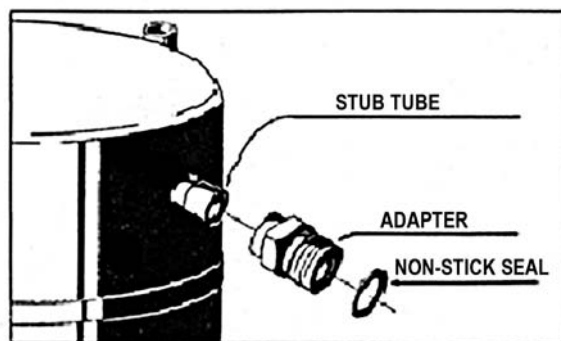

Rotalock to Stub Tube

Thread Size	Stub Tube I.D.	Non-Stick Seal	Adapter Kit*
1" - 14	1/2"	020-0028-00	998-0034-18
1" - 14	5/8"	020-0028-00	998-0034-17
1-1/4" - 12	3/4"	020-0028-02	998-0034-07
1-1/4" - 12	7/8"	020-0028-02	998-0034-08
1-1/4" - 12	1-1/8"	020-0028-02	998-0034-09
1-3/4" - 12	1-1/8"	020-0028-03	998-0034-10
1-3/4" - 12	1-3/8"	020-0028-03	998-0034-13
2-1/4" - 12	1-3/8"	020-0941-00	998-0034-11
2-1/4" - 12	1-5/8"	020-0941-00	998-0034-12

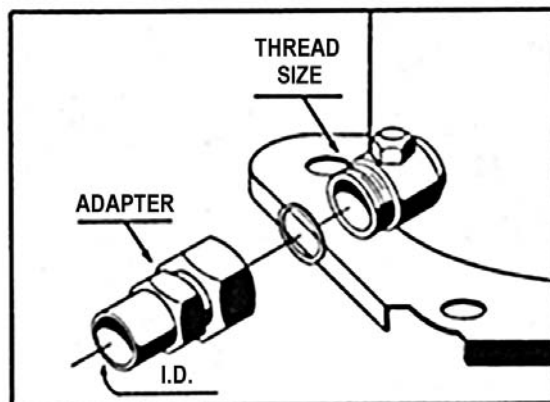

* Adapter kit includes the adapter and the appropriate non-stick seal.

Service Molded Plug Reference Guide

Part Number	Description	Wire		Wire Size - Color		
		Lead Length	Lead End	L1/C	L2/S	L3/R
529-0060-02	Fits ZR and CR models	42 inches	Stripped	12 ga black	12 ga yellow	12 ga red
529-0060-04*	Fits ZR and CR models	42 Inches	Stripped	10 ga black	10 ga yellow	10 ga red
529-0060-05	Fits ZR and CR models	28 inches	Connectors	14 ga black	14 ga blue	14 ga red
529-0060-06	Fits ZR and CR models	48 inches	Connectors	14 ga black	14 ga blue	14 ga red
529-0061-00	Low voltage UltraTech™ solenoid cable with rectifier	54 inches	Stripped	20 ga red	20 ga black	n/a
529-0062-00	Low voltage UltraTech™ solenoid cable without rectifier (CA2 only)	54 inches	Connectors	20 ga red	20 ga black	n/a

*Most common part number

Refrigerants/Lubricants Approved for Use in Copeland® Compressors

	Refrigerants	Similar To	Application		Lubricant Choices			Comments
			Retrofit	New	Preferred	Alternate #1	Alternate #2	
Ozone Depleting	CFC R-12		L,M		MIN	AB & MIN		Phased Out in 1996
	CFC R-502		L,M		MIN	AB & MIN	POE-32	Phased Out in 1996
	HCFC R-22		L,M,H		MIN	AB & MIN	POE-32	No New Equipment 2010
Interims	HCFC R401A	R-12	M,H		AB & MIN	POE-32 & MIN	POE-32	Service Only Suva® MP39
	HCFC R-401B	R-12	L,M		AB & MIN	POE-32 & MIN	POE-32	Service Only Suva® MP66
	HCFC R-402A	R-502	L,M		AB & MIN	POE-32 & MIN	POE-32	Service Only Suva® HP80
	HCFC R-402B	R-502	L,M		AB & MIN	POE-32 & MIN	POE-32	Service Only Suva® HP81
	HCFC R-408A	R-502	L,M		AB & MIN	POE-32 & MIN	POE-32	Service Only FX10
	HCFC R-409A	R-12	L,M		AB & MIN	POE-32 & MIN	POE-32	Service Only FX56
Non-Ozone Depleting	HFC R-134a	R-12	M,H	M,H	POE-32			
	HFC R-404A	R-502	L,M	L,M	POE-32			Suva® HP62, Forane® FX70
	HFC R-507	R-502	L,M	L,M	POE-32			Genetron® AZ50
	HFC R-407A	R-22	L,M	L,M	POE-32			
	HFC R-407C	R-22	L,M,H	L,M,H	POE-32			Suva® 9000/KLEA 66
	HFC R-410A			M,H	POE-32			ZP & ZB KCP Copeland Scroll® Models Only
	HFC R-422A/D	R-22	L,M		MIN	POE-32	AB	Discus® Supermarket Racks Only
	HFC R-438A	R-22	L,M		MIN	POE-32	AB	Discus® Supermarket Racks Only; ISCEON® MO99
	R-704 Helium			Cryogenic	PAG			ZC Copeland Scroll® Models Only
	R-744 CO ₂			Sub-Critical	POE**			ZO Copeland Scroll® Models Only

Legend:

MIN*: Mineral Oil (Copeland® 46BWMO, Sonneborn Suniso 3GS), Chevron/Texaco Capella Wf32) *Mineral oils are interchangeable for 'top off' purposes

AB: Alkyl Benzene Oil (Copeland® Ultra 200, Shrieve Zerol 200 TD, Sonneborn Suniso AKB200A, Shell 2212)

POE 32: Polyolester Oil (Copeland® Ultra 32-3MAF, Lubrizol Emkarate RL32-3MAF, Parker EMKARATE RL32-3MAF/ (Virginia) LE323MAF, Nu Calgon 4314-66 (EMKARATE RL32-3MAF)

Hatcol 22 CC, Copeland® Ultra 22 CC & Mobil Arctic 22 CC (last three for 'top off' only)

POE**: Contact Application Engineer for oil details

PAG: Polyalkylene Glycol Oil (Lubrizol RPAG 62, UCON LB300X)

POE-32 & MIN: Minimum 50% POE

AB & MIN: Minimum 50% Alkyl Benzene

L: Low Temperature Application (Refrigeration) For R-407A, R-407C, R-422A/D, R-438A, Demand Cooling® is required for low temperature application - See AE guidelines for details

M: Medium Temperature Application (Refrigeration)

H: High Temperature Application (Air-Conditioning, Heat Pump, Refrigeration)

For specific product availability and performance data refer to Emerson Climate Technologies, Inc. sales literature
Refer To Application Bulletins, Change-Over Guidelines And MSDS Sheets for additional information at EmersonClimate.com

Copeland Scroll® Service Compressor Specification Chart

Model	ARI Capacity Btu/hr	RLA Amps TF5/TFD	Run Cap. MFD/Volts	Diameter Inches (A)	Suction Height Inches (B)	Discharge Height Inches (C)	Height Inches (D)	Weight Lbs.	Suction Diameter Inches
ZR16K5-PFV	15,500	9.3	30/370	5.5	10.1	14.2	15.3	47	3/4
ZR18K5-PFV	18,000	10.7	30/370	5.5	10.1	14.2	15.3	47	3/4
ZR21K5-PFV	21,000	12.0	35/370	5.5	10.1	14.2	15.3	47	3/4
ZR21K5-TF5/D	21,000	8.6/4.3	N/A	5.5	10.1	14.2	15.3	45	3/4
ZR25K5-PFV	25,300	15.0	40/370	5.5	10.1	14.2	15.3	50	3/4
ZR25K5-TF5/D	25,300	8.9/4.6	N/A	5.5	10.1	14.2	15.3	48	3/4
ZR28K5-PFV	28,400	15.7	45/370	5.5	10.1	14.2	15.3	50	3/4
ZR28K5-TF5/D	28,400	11.1/5.7	N/A	5.5	10.1	14.2	15.3	48	3/4
ZR32K5-PFV	32,600	17.1	50/370	5.5	10.1	14.2	15.3	50	3/4
ZR32K5-TF5/D	32,600	12/6.4	N/A	5.5	10.1	14.2	15.3	49	3/4
ZR38K5-PFV	38,000	21.4	55/370	6.5	11.1	15.4	16.4	64	7/8
ZR38K5-TF5/D	38,000	13.6/6.4	N/A	6.5	11.1	15.4	16.4	60	7/8
ZR42K5-PFV	42,200	22.1	55/370	6.5	11.1	15.4	16.4	68	7/8
ZR42K5-TF5/D	42,200	14.3/6.4	N/A	6.5	11.1	15.4	16.4	61	7/8
ZR48K5-PFV	48,200	24.3	60/440	6.5	11.1	15.4	16.4	72	7/8
ZR48K5-TF5/D	48,200	17.1/7.9	N/A	6.5	11.1	15.4	16.4	68	7/8
ZR54K5-PFV	53,500	28.2	80/370	6.5	11.1	15.4	16.4	73	7/8
ZR54K5-TF5/D	53,500	17.1/7.9	N/A	6.5	11.1	15.4	16.4	69	7/8
ZR57K3-PFV	58,000	32.1	80/370	7.3	11.68	16.13	18	90	7/8
ZR57K3-TF5/D	58,500	19.3/9.1	N/A	7.3	11.68	16.13	18	85	7/8
ZR61K3-PFV	62,000	32.1	80/370	7.3	11.68	16.13	18	90	7/8
ZR61K3-TF5/D	62,000	19.3/9.1	N/A	7.3	11.68	16.13	18	85	7/8

Mounting pattern 7.5"x7.5" (same as previous Copeland Scroll models)

Rotalock™ Kit Part Numbers			
		Adapter	Seal
Suction	3/4" to 1-1/4"-12	998-0034-01	020-0028-02
Suction	7/8" to 1-1/4"-12	998-0034-02	020-0028-02
Discharge	1/2" to 1"-14	998-0034-15	020-0028-00

Additional information

Copeland Scroll ZRK5 compressors are offered in an -800 bill-of-material option, such as ZR25K5-PFV-800, that includes the compressor with a 42 inch molded plug wiring harness, mounting parts and installation instructions.

Other available information includes:

A/C Compressor Product Guide (2008ECT-113)

ZRK5 Product Brochure (2009ECT-98)

For complete product details and additional information, visit EmersonClimate.com and select Online Product Information (OPI) or CopelandScroll.com.

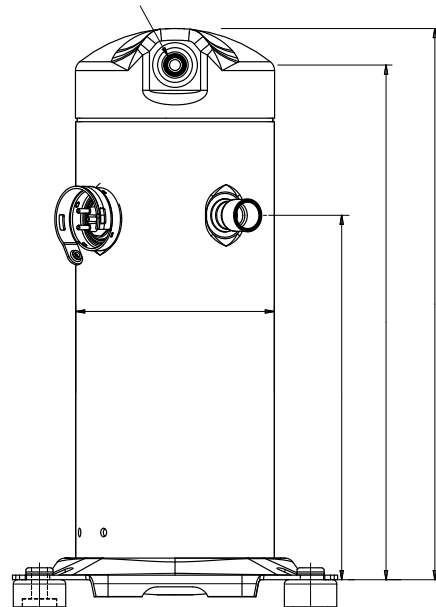

EmersonClimate.com

2008ECT-113 R2 (10/10) Emerson, Copeland, Copeland Scroll and UltraTech are trademarks of Emerson Electric Co. or one of its affiliated companies. ©2008 Emerson Climate Technologies, Inc. All rights reserved. Printed in the USA.

