

Wiring Configuration

INSTALLATION ADDENDUM

ADVANCED MODELS (HE150/HE250/HE300)

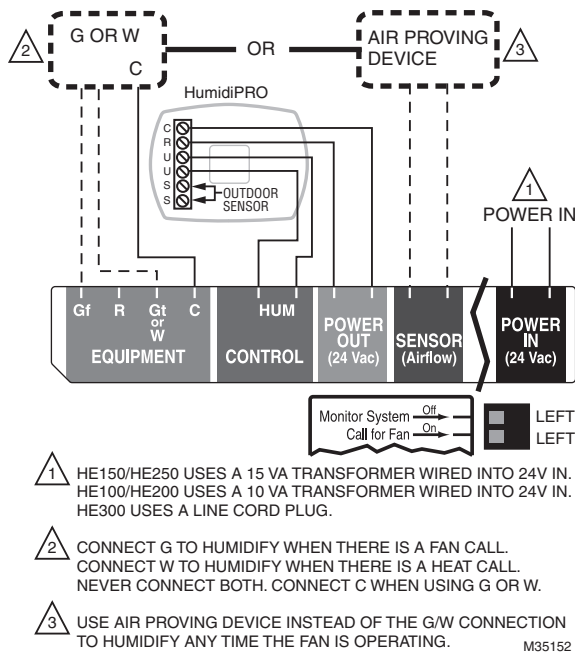

Fig. 1. Wiring HumidiPRO (H6062) to humidify only with a call for Heat or Fan.

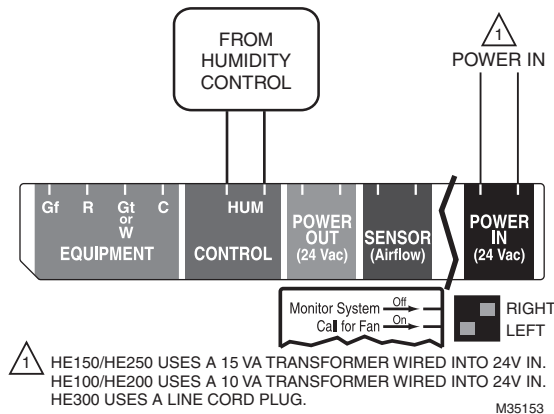

Fig. 2. Wiring TrueIAQ, VisionPRO IAQ, or Prestige, using the intelligent control to program humidity calls with heat, cool, or on demand.



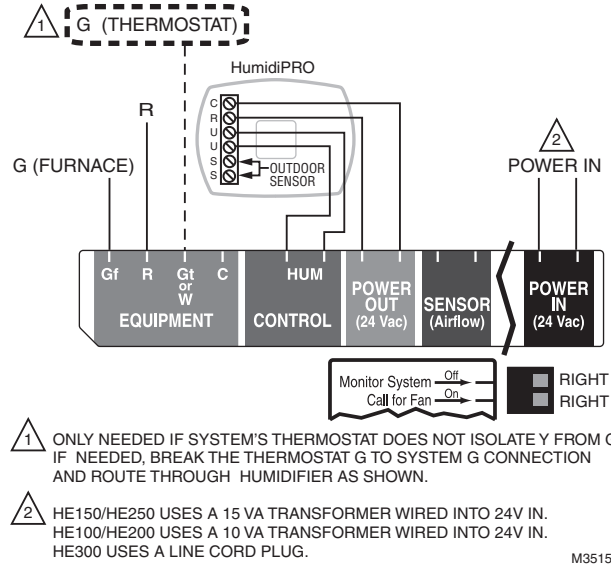

Fig. 3. Wiring to force the HVAC system fan on whenever humidity is needed (on demand).

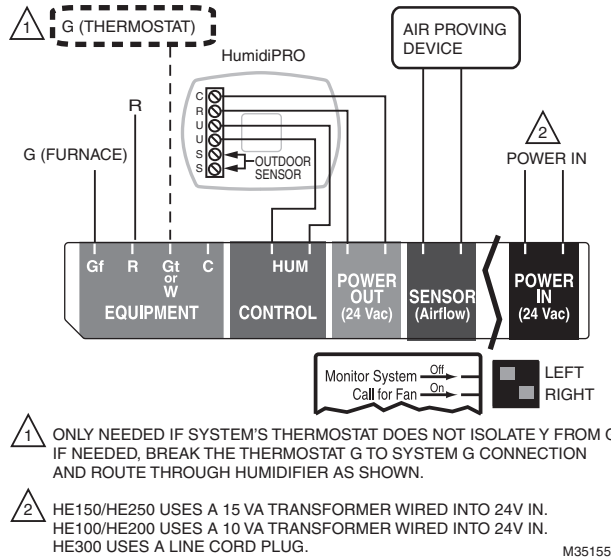

Fig. 4. Wiring to force fan on and prove airflow in the duct.

BASIC MODELS (HE100/HE200)

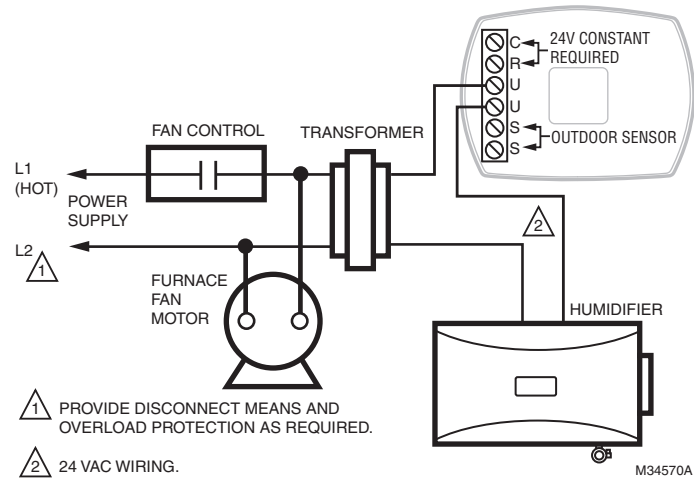

Fig. 5. Wiring HumidiPRO with fan interlock.

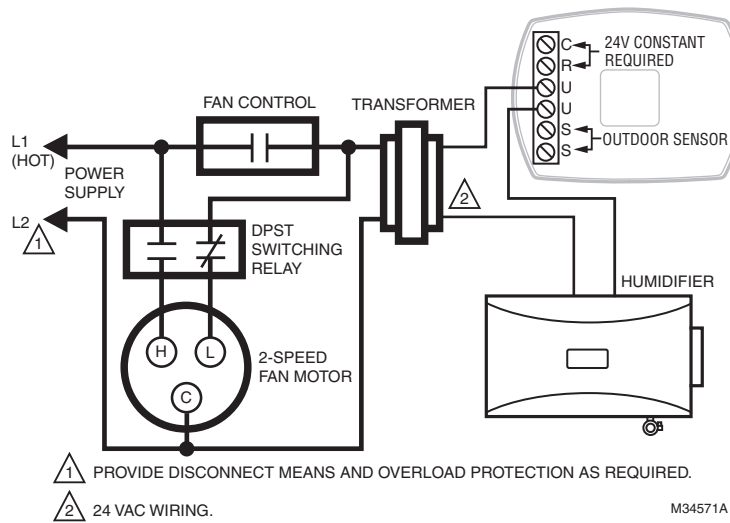

Fig. 6. Wiring HumidiPRO with 2-speed fan motor.

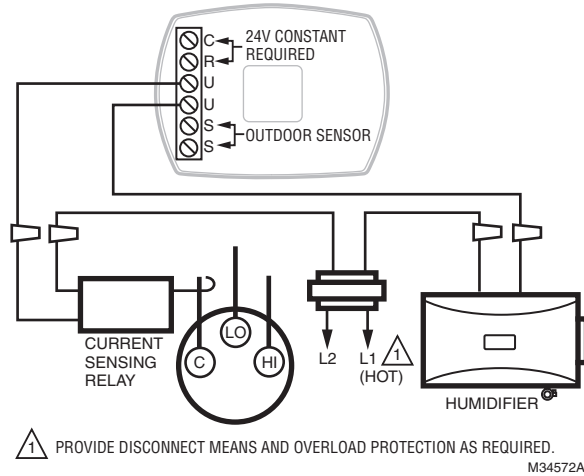

Fig. 7. Wiring HumidiPRO with current sensing relay.

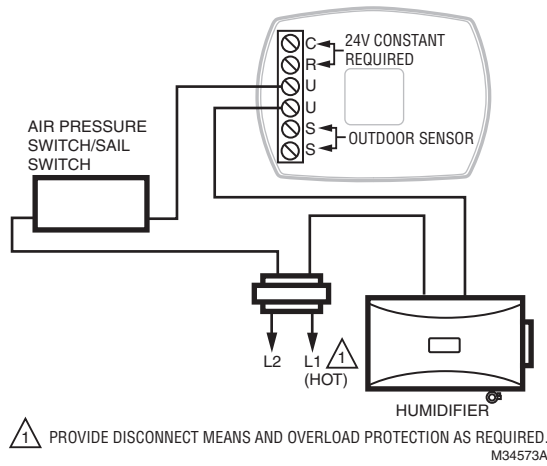

Fig. 8. Wiring HumidiPRO with air proving device.

Automation and Control Solutions

Honeywell International Inc.
1985 Douglas Drive North
Golden Valley, MN 55422

Honeywell Ltd
705 Montrichard Avenue
Saint-Jean-sur-Richelieu, Québec
J2X 5K8
customer.honeywell.com

