

Copeland® condensing unit

Selection guide for commercial refrigeration



Contents

Module	Form Number	Last Revised
M and F Line SystemPro® hermetic air-cooled condensing units	2011DS-4_M&F	4/11
Copeland Scroll outdoor condensing units for refrigeration applications	2011DS-4_XJ	4/11
F and D Line Copeland Scroll® air-cooled condensing units	2011DS-4_F&D	4/11
Copevap® hermetic air-cooled condensing units	2011DS-4_Copevap	4/11
M and F Line SystemPro® hermetic water-cooled condensing units	2011DS-4_M&Fwater	4/11
C, D and E Line Copelametic® air-cooled condensing units	2011DS-4_CD&E	4/11
W Line semi-hermetic water-cooled condensing units	2011DS-4_W	4/11
Appendix	2011DS-4_Appendix	4/11

This page will be updated each time a module is revised. We recommend it be included when ordering updated modules.

M and F Line

SystemPro[®] hermetic air-cooled condensing units

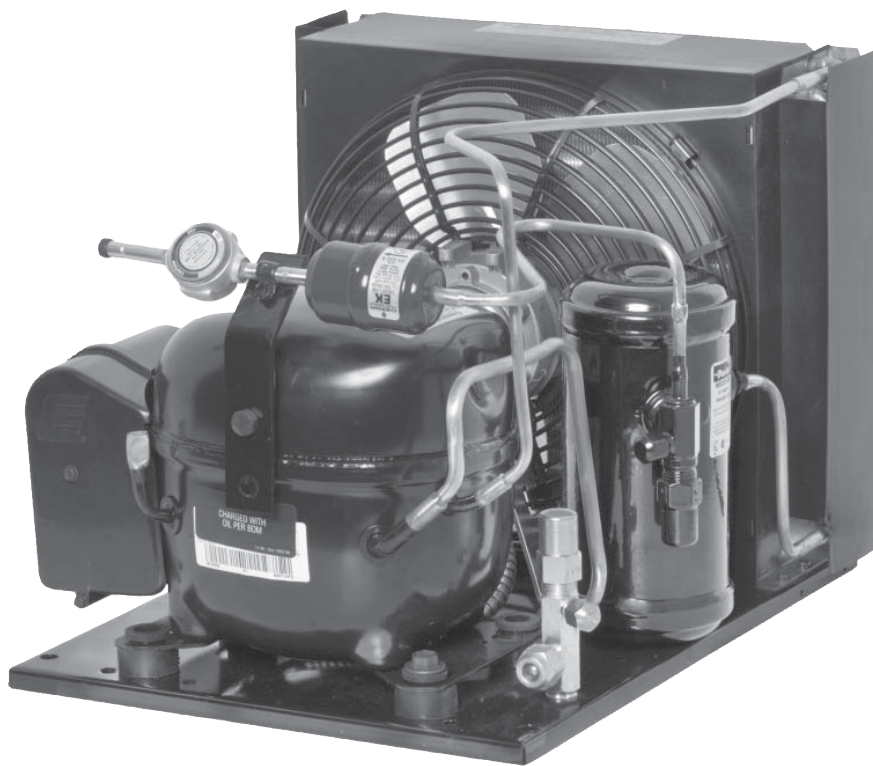

Product Information

Horsepower:	1/6 – 5
Temperature Applications:	Low/Medium/High
Refrigerants:	R-134a, R-404A, R-22, R-407C
Installation Applications:	A variety of applications including under-counter coolers, food prep tables, reach-in cases, and walk-in boxes

Nomenclature • Welded Condensing Units

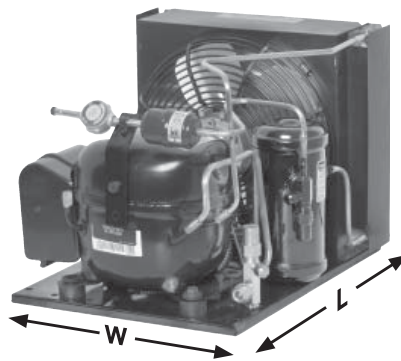
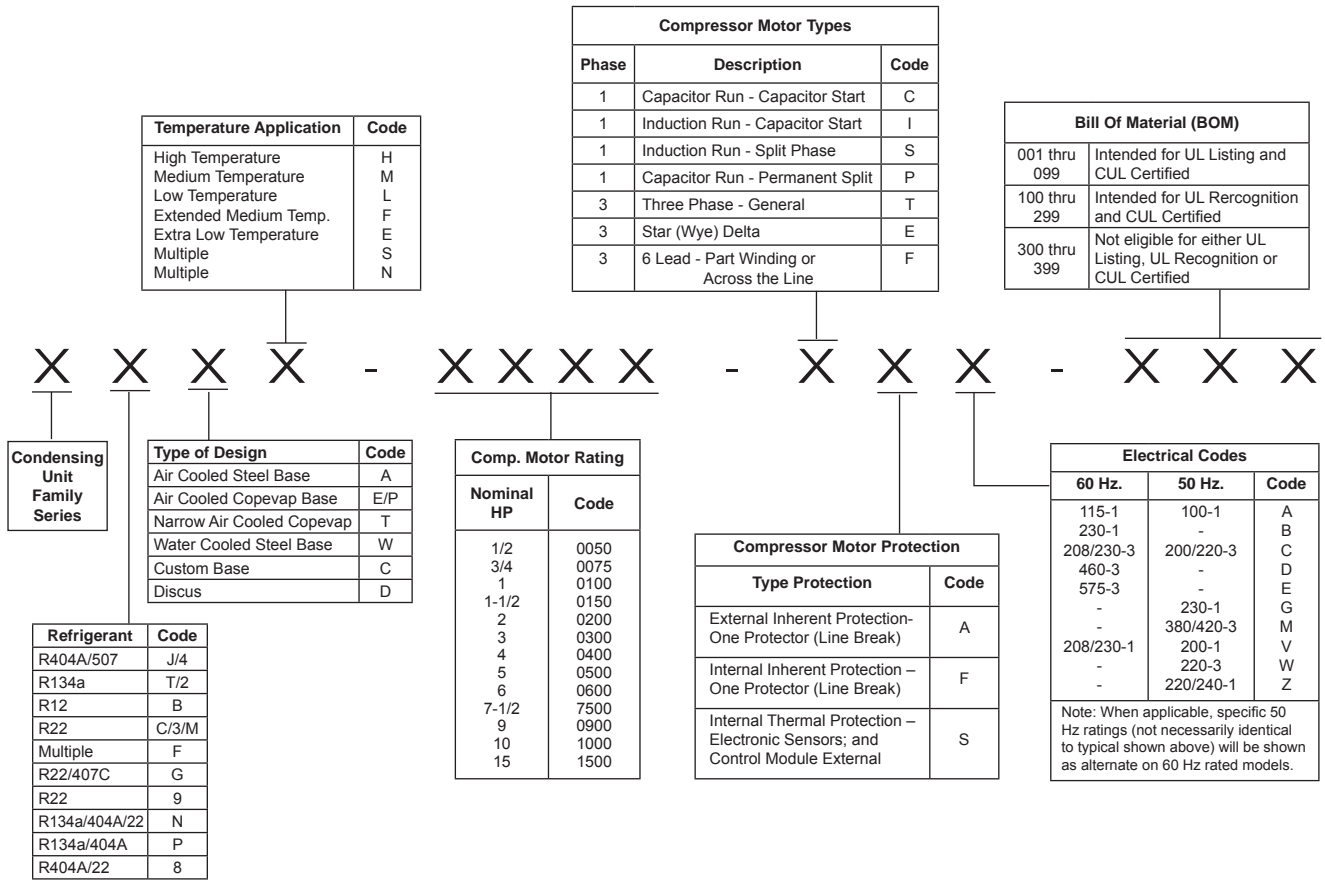

Unit Features

Flare BOM (Obsolete)	Sweat BOM	Suction Connections		Liquid Connections		Filter Drier	Sight Glass	Electrical Connections		Fan Cycle Control	Fan Guard	UL/UR
		Suction Valve	Suction Accumulator	Base Valve	Receiver w/Valve			Power Cord	BX Conduit			
105, 106	111	•		•				•				UR
109	103	•			•			•				UR
201	212	•			•				•		•	UR*
010	015	•	•		•				•	•	•	UL
001	020	•			•				•		•	UL
	072	•			•	•	•		•		•	UL
	272	•			•	•	•		•		•	UR

*These recognized models are identical to listed models less pressure control. Need for the control is to be evaluated in the end use application.

SystemPro® hermetic air-cooled condensing units

Features	Benefits
Copeland® Hermetic Compressor and Heavy Duty Unit Bearing Fan Motor	Reliability
	High Energy Efficiency
	Low Sound & Vibration
Modular Components	Replacement Serviceability
Compact Design	Application Flexibility
All Models Rated Up To 110°F Ambient	

Resources and Support

EmersonClimate.com

- Online Product Information and Technical Data
 - Application Engineering Bulletins
 - Instruction Sheets
 - Marketing Brochures
- Product Selection Tools
 - Walk-In Box Load Calculator
- Software
 - Quick Selection Slide Rule
- Where to Buy

Application Engineering Bulletins

- 4-1273 Factors to Consider in Converting Compressor Rated Capacity to Actual Capacity
- 4-1292 Medium Temperature R-22 Copelaweld Compressors
- 4-1295 HFC-134A Refrigerant Guidelines
- 4-1298 Extended Medium Temperature R-404A/507 Hermetic Compressors and Condensing Units
- 4-1305 “SystemPro” AF, AR, & AS Refrigeration Hermetic 1/8-1 Horsepower Compressors
- 4-1306 Application Guidelines for RF Low Temperature Refrigeration Compressors
- 4-1307 Application Guidelines for CF Refrigeration Compressors and Condensing Units
- 4-1344 Application Guidelines for RFT, RRT, RST Compressors
- 11-1147 Suction Accumulators
- 17-1260 Compressor Overheating
- 17-1268 Compression Ratio as it Affects Compressor Reliability
- 22-1182 Liquid Refrigerant Control in Refrigeration and Air Conditioning Systems

For more information, visit EmersonClimate.com and login to the Customer Portal to view Online Product Information

SystemPro® air-cooled condensing units

Capacity Data

HIGH/MED TEMP		Capacity (BTU/Hr) at 90° Ambient - Evaporator Temp (°F)						
Model	BOM	Refrig.	H.P.	0	+10	+15	+20	+25
M2FH-0017-SAA	111	134a	1/6		800	910	1030	1150
M2FH-0020-IAA	111	134a	1/5		950	1070	1200	1330
MMFH-0022-IAA	111	22	1/5		1250	1380	1530	1680
M4FH-0022-IAA	111	404A	1/5		1340	1460	1590	1720
M2FH-0024-SAA	111	134a	1/4		1310	1470	1640	1810
M2FH-0026-IAA	072,111,103	134a	1/4		1530	1700	1890	2080
MCFH-0027-IAA	111,103,272	22	1/4		1910	2130	2360	2600
M4FH-0025-IAA	103,272	404A	1/4		1890	2060	2240	2430
M2FH-A033-IAA, IAV	111,103,272	134a	1/3		1870	2110	2360	2620
MCFH-0036-IAA	111,103,272	22	1/3		2270	2550	2830	3140
M4FH-A036-IAA, IAV	111,103,272	404A	1/3		2550	2810	3090	3370
M2FH-0049-IAA, IAV	111,103,272	134a	1/2		2610	2920	3250	3600
MCFH-0049-CAA, CAV	111,103,272	22	1/2		3090	3460	3840	4250
M2FH-0050-IAA-IAV	111,103,272	134a	1/2		2950	3350	3780	4230
M4FF-0050-IAA, IAV	212	404A	1/2	2890	3660	3980	4320	4660
M4FF-0056-IAA, IAV	103,212,272	404A	1/2	3140	3920	4330	4750	5180
M2FH-0056-IAA, IAV	111,103,272	134a	1/2		3240	3680	4140	4630
MCFH-0056-IAA, IAV	111,103,272	22	1/2		3610	4020	4470	4950
M4FH-0050-CAA, CAV	111,103,272	404A	1/2		3320	3660	4010	4380
FTAH-B074-IAA, IAV	212	134a	3/4		3890	4380	4900	5450
FTAM-A075-IAA, IAV	020	134a	3/4		4260	4920	5650	6450
F3AH-A078-IAA, IAV	020	22	3/4		4480	5120	5760	6450
M4FF-0075-CAA, CAV	020	404A	3/4	4000	5010	5550	6090	6660
FTAH-A101-CFV, TFC, TFD	020	134a	1		4990	5860	6820	7770
F3AH-A100-CAV	020	22	1		5260	5960	6700	7480
FJAF-0106-CAV	020	404A	1	5160	6420	7080	7780	8500
F3AM-A105-CFV, TFC	020	22	1		6530	7530	8530	9590
FTAH-A125-CFV, TFC, TFD	020	134a	1-1/4		7170	8420	9770	11200
FJAM-A125-CFV, TFC	020	404A	1-1/4	5390	6840	7620	8450	9340
FJAM-A126-CAV, TFC	020	404A	1-1/4	6350	7940	8770	9640	10500
FTAH-A150-CFV, TFC, TFD	020	134a	1-1/2			10000	11600	13300
FGAH-A151-CFV, TFC, TFD	020	22	1-1/2		7590	8800	10100	11500
FGAH-A151-CFV, TFC, TFD	020	407C	1-1/2	5470	7630	8770	9940	11200
FJAM-A150-CFV, TFC, TFD	020	404A	1-1/2	6860	9100	10200	11400	12500
FTAH-A201-CFV, TFC, TFD	020	134a	2		10300	12200	14200	16400
FGAH-A201-CFV, TFC, TFD	015, 020	22	2		10100	11800	13500	15400
FGAH-A201-CFV, TFC, TFD	015, 020	407C	2		9790	11300	12900	14500
FJAM-A200-CFV, TFC	020	404A	2	8770	11600	13000	14500	16100
FJAM-A225-CFV, TFC, TFD	020	404A	2-1/4	10400	13400	14900	16400	17900
FGAH-A225-CFV, TFC, TFD	015, 020	22	2-1/4		11400	13100	15100	17100
FGAH-A225-CFV, TFC, TFD	015, 020	407C	2-1/4	8110	11400	13200	15000	16800
FGAH-A301-CFV, TFC, TFD	015, 020	22	3		17000	19500	22000	24600
FGAH-A301-CFV, TFC, TFD	015, 020	407C	3	10100	14900	17400	19900	22600
FJAM-A300-CFV, TFC, TFD	020	404A	3	13100	17300	19500	21600	23800
FGAH-A325-CFV, TFC, TFD	015, 020	22	3-1/4		18300	20900	23600	26500
FGAH-A325-CFV, TFC, TFD	015, 020	407C	3-1/4	11200	16400	19100	21900	24800
FJAM-A325-CFV, TFC, TFD	020	404A	3-1/4	14300	18500	20800	23300	26100
FGAH-A401-CFV, TFC, TFD	015, 020	22	4		25900	29500	33400	37600
FGAH-A401-CFV, TFC, TFD	015, 020	407C	4	15500	23000	26900	30900	35200
FJAM-B400-CFV, TFC, TFD	020	404A	4	20700	26900	30300	33900	37800
FGAH-A501-CFV, TFC, TFD, TFE	015, 020	22	5		29800	34000	38200	42700
FGAH-A501-CFV, TFC, TFD, TFE	015, 020	407C	5	22500	30400	34500	38800	43200
FJAM-B500-CFV, TFC	020	404A	5	23200	30400	34100	37700	41200

Capacities are at 60 Hertz with 5°F subcooling.
 HT models are rated at 65°F return gas temperature.
 MT models are rated at 40°F return gas temperature

SystemPro® air-cooled condensing units

Capacity Data

HIGH/MED TEMP		Capacity (BTU/Hr) at 90° Ambient - Evaporator Temp (°F)					
Model	BOM	Refrig.	H.P.	+30	+35	+40	+45
M2FH-0017-SAA	111	134a	1/6	1280	1410	1560	1710
M2FH-0020-IAA	111	134a	1/5	1470	1620	1770	1930
MMFH-0022-IAA	111	22	1/5	1840	2010	2180	2360
M4FH-0022-IAA	111	404A	1/5	1860	2010	2160	2310
M2FH-0024-SAA	111	134a	1/4	2000	2190	2390	2600
M2FH-0026-IAA	072,111,103	134a	1/4	2280	2490	2710	2940
MCFH-0027-IAA	111,103,272	22	1/4	2850	3110	3380	3660
M4FH-0025-IAA	103,272	404A	1/4	2620	2820	3030	3240
M2FH-A033-IAA, IAV	111,103,272	134a	1/3	2900	3190	3500	3820
MCFH-0036-IAA	111,103,272	22	1/3	3460	3790	4140	4500
M4FH-A036-IAA, IAV	111,103,272	404A	1/3	3670	3990	4310	4650
M2FH-0049-IAA, IAV	111,103,272	134a	1/2	3960	4340	4740	5150
MCFH-0049-CAA, CAV	111,103,272	22	1/2	4680	5130	5600	6090
M2FH-0050-IAA-IAV	111,103,272	134a	1/2	4710	5210	5740	6290
M4FF-0050-IAA, IAV	212	404A	1/2				
M4FF-0056-IAA, IAV	103,212,272	404A	1/2				
M2FH-0056-IAA, IAV	111,103,272	134a	1/2	5150	5690	6270	6870
MCFH-0056-IAA, IAV	111,103,272	22	1/2	5480	6070	6720	7440
M4FH-0050-CAA, CAV	111,103,272	404A	1/2	4770	5180	5600	6040
FTAH-B074-IAA, IAV	212	134a	3/4	6050	6710	7430	8220
FTAM-A075-IAA, IAV	020	134a	3/4				
F3AH-A078-IAA, IAV	020	22	3/4	7130	7870	8660	9440
M4FF-0075-CAA, CAV	020	404A	3/4				
FTAH-A101-CFV, TFC, TFD	020	134a	1	8780	9790	10800	11800
F3AH-A100-CAV	020	22	1	8320	9220	10200	11200
FJAF-0106-CAV	020	404A	1				
F3AM-A105-CFV, TFC	020	22	1				
FTAH-A125-CFV, TFC, TFD	020	134a	1-1/4	12800	14400	16200	18000
FJAM-A125-CFV, TFC	020	404A	1-1/4				
FJAM-A126-CAV, TFC	020	404A	1-1/4				
FTAH-A150-CFV, TFC, TFD	020	134a	1-1/2	15100	17000	19000	21100
FGAH-A151-CFV, TFC, TFD	020	22	1-1/2	13000	14500	16100	17700
FGAH-A151-CFV, TFC, TFD	020	407C	1-1/2	12500	13800	15200	16700
FJAM-A150-CFV, TFC, TFD	020	404A	1-1/2				
FTAH-A201-CFV, TFC, TFD	020	134a	2	18800	21300	24000	26900
FGAH-A201-CFV, TFC, TFD	015, 020	22	2	17300	19400	21600	23900
FGAH-A201-CFV, TFC, TFD	015, 020	407C	2	16200	18000	19900	21900
FJAM-A200-CFV, TFC	020	404A	2				
FJAM-A225-CFV, TFC, TFD	020	404A	2-1/4				
FGAH-A225-CFV, TFC, TFD	015, 020	22	2-1/4	19300	21500	23900	26400
FGAH-A225-CFV, TFC, TFD	015, 020	407C	2-1/4	18800	20800	23000	25200
FGAH-A301-CFV, TFC, TFD	015, 020	22	3	27400	30300	33300	36500
FGAH-A301-CFV, TFC, TFD	015, 020	407C	3	25400	28300	31400	34700
FJAM-A300-CFV, TFC, TFD	020	404A	3				
FGAH-A325-CFV, TFC, TFD	015, 020	22	3-1/4	29400	32500	35900	39400
FGAH-A325-CFV, TFC, TFD	015, 020	407C	3-1/4	27900	31100	34400	38000
FJAM-A325-CFV, TFC, TFD	020	404A	3-1/4				
FGAH-A401-CFV, TFC, TFD	015, 020	22	4	41900	46500	51200	56200
FGAH-A401-CFV, TFC, TFD	015, 020	407C	4	39700	44400	49500	54800
FJAM-B400-CFV, TFC, TFD	020	404A	4				
FGAH-A501-CFV, TFC, TFD, TFE	015, 020	22	5	47400	52400	57500	63000
FGAH-A501-CFV, TFC, TFD, TFE	015, 020	407C	5	47800	52600	57600	62800
FJAM-B500-CFV, TFC	020	404A	5				

Capacities are at 60 Hertz with 5°F subcooling.
 HT models are rated at 65°F return gas temperature.
 MT models are rated at 40°F return gas temperature

SystemPro® air-cooled condensing units

Capacity Data

HIGH/MED TEMP		Capacity (BTU/Hr) at 100° Ambient - Evaporator Temp (°F)						
Model	BOM	Refrig.	H.P.	0	+10	+15	+20	+25
M2FH-0017-SAA	111	134a	1/6		730	830	930	1050
M2FH-0020-IAA	111	134a	1/5		890	1010	1120	1250
MMFH-0022-IAA	111	22	1/5		1140	1270	1400	1550
M4FH-0022-IAA	111	404A	1/5		1230	1340	1460	1590
M2FH-0024-SAA	111	134a	1/4		1230	1390	1530	1710
M2FH-0026-IAA	072,111,103	134a	1/4		1400	1570	1710	1890
MCFH-0027-IAA	111,103,272	22	1/4		1710	1930	2150	2380
M4FH-0025-IAA	103,272	404A	1/4		1700	1870	2030	2220
M2FH-A033-IAA, IAV	111,103,272	134a	1/3		1690	1920	2150	2420
MCFH-0036-IAA	111,103,272	22	1/3		2080	2330	2600	2890
M4FH-A036-IAA, IAV	111,103,272	404A	1/3		2330	2580	2840	3100
M2FH-0049-IAA, IAV	111,103,272	134a	1/2		2410	2710	3020	3350
MCFH-0049-CAA, CAV	111,103,272	22	1/2		2910	3260	3630	4010
M2FH-0050-IAA-IAV	111,103,272	134a	1/2		2730	3170	3500	3860
M4FF-0050-IAA, IAV	212	404A	1/2	2660	3260	3550	3850	4140
M4FF-0056-IAA, IAV	103,212,272	404A	1/2	2780	3490	3860	4240	4630
M2FH-0056-IAA, IAV	111,103,272	134a	1/2		3010	3430	3880	4220
MCFH-0056-IAA, IAV	111,103,272	22	1/2		3270	3660	4070	4520
M4FH-0050-CAA, CAV	111,103,272	404A	1/2		2900	3220	3560	3910
FTAH-B074-IAA, IAV	212	134a	3/4		3420	3870	4350	4860
FTAM-A075-IAA, IAV	020	134a	3/4		3870	4430	5070	5780
F3AH-A078-IAA, IAV	020	22	3/4		4020	4620	5220	5860
M4FF-0075-CAA, CAV	020	404A	3/4	3540	4470	4960	5460	5980
FTAH-A101-CFV, TFC, TFD	020	134a	1		4330	5160	6060	6970
F3AH-A100-CAV	020	22	1		4740	5440	6140	6910
FJAF-0106-CAV	020	404A	1	4650	5800	6410	7040	7700
F3AM-A105-CFV, TFC	020	22	1		5750	6700	7640	8650
FTAH-A125-CFV, TFC, TFD	020	134a	1-1/4		6190	7360	8620	9970
FJAM-A125-CFV, TFC	020	404A	1-1/4	4770	6070	6750	7470	8250
FJAM-A126-CAV, TFC	020	404A	1-1/4	5610	7060	7810	8600	9420
FTAH-A150-CFV, TFC, TFD	020	134a	1-1/2		7370	8760	10200	11800
FGAH-A151-CFV, TFC, TFD	020	22	1-1/2		6490	7630	8850	10200
FGAH-A151-CFV, TFC, TFD	020	407C	1-1/2	4810	6860	7940	9050	10200
FJAM-A150-CFV, TFC, TFD	020	404A	1-1/2	5780	7820	8850	9890	10900
FTAH-A201-CFV, TFC, TFD	020	134a	2		8880	10700	12600	14600
FGAH-A201-CFV, TFC, TFD	015, 020	22	2		8930	10500	12200	13900
FGAH-A201-CFV, TFC, TFD	015, 020	407C	2	6110	8820	10200	11700	13300
FJAM-A200-CFV, TFC	020	404A	2	7500	10100	11400	12800	14200
FJAM-A225-CFV, TFC, TFD	020	404A	2-1/4	9060	11700	13100	14500	15800
FGAH-A225-CFV, TFC, TFD	015, 020	22	2-1/4		10100	11800	13600	15500
FGAH-A225-CFV, TFC, TFD	015, 020	407C	2-1/4	7120	10300	11900	13600	15400
FGAH-A301-CFV, TFC, TFD	015, 020	22	3	15100	17400	19900	22400	25000
FGAH-A301-CFV, TFC, TFD	015, 020	407C	3	8360	12900	15200	17600	20100
FJAM-A300-CFV, TFC, TFD	020	404A	3	11200	15000	17000	18900	20900
FGAH-A325-CFV, TFC, TFD	015, 020	22	3-1/4		16500	19000	21600	24200
FGAH-A325-CFV, TFC, TFD	015, 020	407C	3-1/4	9160	14200	16700	19300	22000
FJAM-A325-CFV, TFC, TFD	020	404A	3-1/4	12200	16000	18100	20400	22900
FGAH-A401-CFV, TFC, TFD	015, 020	22	4		23500	27000	30600	34500
FGAH-A401-CFV, TFC, TFD	015, 020	407C	4	12700	19900	23600	27500	31500
FJAM-B400-CFV, TFC, TFD	020	404A	4	18100	23700	26800	30000	33500
FGAH-A501-CFV, TFC, TFD, TFE	015, 020	22	5		28000	32100	36300	40600
FGAH-A501-CFV, TFC, TFD, TFE	015, 020	407C	5		27600	31600	35700	40000
FJAM-B500-CFV, TFC	020	404A	5	20400	27000	30300	33600	36700

Capacities are at 60 Hertz with 5°F subcooling.
 HT models are rated at 65°F return gas temperature.
 MT models are rated at 40°F return gas temperature

SystemPro® air-cooled condensing units

Capacity Data

HIGH/MED TEMP		Capacity (BTU/Hr) at 100° Ambient - Evaporator Temp (°F)					
Model	BOM	Refrig.	H.P.	+30	+35	+40	+45
M2FH-0017-SAA	111	134a	1/6	1170	1300	1440	1580
M2FH-0020-IAA	111	134a	1/5	1380	1520	1670	1810
MMFH-0022-IAA	111	22	1/5	1700	1870	2030	2190
M4FH-0022-IAA	111	404A	1/5	1720	1870	2010	2150
M2FH-0024-SAA	111	134a	1/4	1870	2050	2230	2420
M2FH-0026-IAA	072,111,103	134a	1/4	2080	2300	2520	2710
MCFH-0027-IAA	111,103,272	22	1/4	2610	2860	3130	3400
M4FH-0025-IAA	103,272	404A	1/4	2400	2620	2840	3030
M2FH-A033-IAA, IAV	111,103,272	134a	1/3	2670	2970	3230	3490
MCFH-0036-IAA	111,103,272	22	1/3	3180	3500	3830	4170
M4FH-A036-IAA, IAV	111,103,272	404A	1/3	3370	3660	3960	4290
M2FH-0049-IAA, IAV	111,103,272	134a	1/2	3690	4050	4430	4800
MCFH-0049-CAA, CAV	111,103,272	22	1/2	4400	4810	5250	5720
M2FH-0050-IAA-IAV	111,103,272	134a	1/2	4360	4820	5340	5940
M4FF-0050-IAA, IAV	212	404A	1/2				
M4FF-0056-IAA, IAV	103,212,272	404A	1/2				
M2FH-0056-IAA, IAV	111,103,272	134a	1/2	4830	5280	5820	6480
MCFH-0056-IAA, IAV	111,103,272	22	1/2	5020	5580	6200	6880
M4FH-0050-CAA, CAV	111,103,272	404A	1/2	4280	4680	5080	5520
FTAH-B074-IAA, IAV	212	134a	3/4	5420	6030	6700	7440
FTAM-A075-IAA, IAV	020	134a	3/4				
F3AH-A078-IAA, IAV	020	22	3/4	6510	7190	7930	8670
M4FF-0075-CAA, CAV	020	404A	3/4				
FTAH-A101-CFV, TFC, TFD	020	134a	1	7930	8900	9850	10800
F3AH-A100-CAV	020	22	1	7670	8490	9360	10200
FJAF-0106-CAV	020	404A	1				
F3AM-A105-CFV, TFC	020	22	1				
FTAH-A125-CFV, TFC, TFD	020	134a	1-1/4	11400	12900	14600	16300
FJAM-A125-CFV, TFC	020	404A	1-1/4				
FJAM-A126-CAV, TFC	020	404A	1-1/4				
FTAH-A150-CFV, TFC, TFD	020	134a	1-1/2	13500	15200	17100	19000
FGAH-A151-CFV, TFC, TFD	020	22	1-1/2	11500	13000	14500	16100
FGAH-A151-CFV, TFC, TFD	020	407C	1-1/2	11400	12700	14000	15400
FJAM-A150-CFV, TFC, TFD	020	404A	1-1/2				
FTAH-A201-CFV, TFC, TFD	020	134a	2	16800	19200	21700	24300
FGAH-A201-CFV, TFC, TFD	015, 020	22	2	15800	17800	19900	22000
FGAH-A201-CFV, TFC, TFD	015, 020	407C	2	14900	16600	18400	20200
FJAM-A200-CFV, TFC	020	404A	2				
FJAM-A225-CFV, TFC, TFD	020	404A	2-1/4				
FGAH-A225-CFV, TFC, TFD	015, 020	22	2-1/4	17600	19700	22000	24300
FGAH-A225-CFV, TFC, TFD	015, 020	407C	2-1/4	17200	19200	21200	23300
FGAH-A301-CFV, TFC, TFD	015, 020	22	3	27700	30600	33600	
FGAH-A301-CFV, TFC, TFD	015, 020	407C	3	22700	25500	28400	31500
FJAM-A300-CFV, TFC, TFD	020	404A	3				
FGAH-A325-CFV, TFC, TFD	015, 020	22	3-1/4	27000	29900	32900	36200
FGAH-A325-CFV, TFC, TFD	015, 020	407C	3-1/4	24900	27900	31000	34400
FJAM-A325-CFV, TFC, TFD	020	404A	3-1/4				
FGAH-A401-CFV, TFC, TFD	015, 020	22	4	38600	42800	47300	51800
FGAH-A401-CFV, TFC, TFD	015, 020	407C	4	35700	40200	44900	50000
FJAM-B400-CFV, TFC, TFD	020	404A	4				
FGAH-A501-CFV, TFC, TFD, TFE	015, 020	22	5	45100	49700	54700	59600
FGAH-A501-CFV, TFC, TFD, TFE	015, 020	407C	5	44300	48900	53600	58500
FJAM-B500-CFV, TFC	020	404A	5				

Capacities are at 60 Hertz with 5°F subcooling.
 HT models are rated at 65°F return gas temperature.
 MT models are rated at 40°F return gas temperature

SystemPro® air-cooled condensing units

Capacity Data

HIGH/MED TEMP		Capacity (BTU/Hr) at 110° Ambient - Evaporator Temp (°F)						
Model	BOM	Refrig.	H.P.	0	+10	+15	+20	+25
M2FH-0017-SAA	111	134a	1/6		660	760	840	950
M2FH-0020-IAA	111	134a	1/5		820	930	1040	1170
MMFH-0022-IAA	111	22	1/5		1050	1170	1300	1440
M4FH-0022-IAA	111	404A	1/5		1130	1230	1350	1480
M2FH-0024-SAA	111	134a	1/4		1140	1290	1420	1590
M2FH-0026-IAA	072,111,103	134a	1/4		1330	1470	1570	1740
MCFH-0027-IAA	111,103,272	22	1/4		1540	1750	1970	2180
M4FH-0025-IAA	103,272	404A	1/4		1530	1690	1840	2020
M2FH-A033-IAA, IAV	111,103,272	134a	1/3		1520	1740	1970	2220
MCFH-0036-IAA	111,103,272	22	1/3		1880	2120	2370	2640
M4FH-A036-IAA, IAV	111,103,272	404A	1/3		2110	2340	2590	2840
M2FH-0049-IAA, IAV	111,103,272	134a	1/2		2210	2490	2790	3100
MCFH-0049-CAA, CAV	111,103,272	22	1/2		2690	3020	3370	3750
M2FH-0050-IAA-IAV	111,103,272	134a	1/2		2470	2890	3210	3560
M4FF-0050-IAA, IAV	212	404A	1/2	2320	2860	3110	3370	
M4FF-0056-IAA, IAV	103,212,272	404A	1/2	2430	3070	3400	3750	4100
M2FH-0056-IAA, IAV	111,103,272	134a	1/2		2750	3120	3520	3870
MCFH-0056-IAA, IAV	111,103,272	22	1/2		2960	3320	3710	4130
M4FH-0050-CAA, CAV	111,103,272	404A	1/2		2660	2940	3240	3530
FTAH-B074-IAA, IAV	212	134a	3/4		3030	3450	3880	4350
FTAM-A075-IAA, IAV	020	134a	3/4		3520	3940	4460	5070
F3AH-A078-IAA, IAV	020	22	3/4		3540	4100	4660	5270
M4FF-0075-CAA, CAV	020	404A	3/4	3120	3960	4400	4850	5310
FTAH-A101-CFV, TFC, TFD	020	134a	1		3680	4450	5310	6160
F3AH-A100-CAV	020	22	1		4230	4870	5520	6210
FJAF-0106-CAV	020	404A	1	4120	5150	5700	6270	6860
F3AM-A105-CFV, TFC	020	22	1	3050	4940	5830	6720	7670
FTAH-A125-CFV, TFC, TFD	020	134a	1-1/4		5230	6330	7500	8750
FJAM-A125-CFV, TFC	020	404A	1-1/4	4070	5230	5820	6440	7100
FJAM-A126-CAV, TFC	020	404A	1-1/4	4850	6150	6820	7530	8260
FTAH-A150-CFV, TFC, TFD	020	134a	1-1/2		6220	7520	8900	10400
FGAH-A151-CFV, TFC, TFD	020	22	1-1/2		5400	6470	7620	8850
FGAH-A151-CFV, TFC, TFD	020	407C	1-1/2		6100	7120	8170	9270
FJAM-A150-CFV, TFC, TFD	020	404A	1-1/2	4680	6520	7450	8380	9310
FTAH-A201-CFV, TFC, TFD	020	134a	2		7480	9150	10900	12800
FGAH-A201-CFV, TFC, TFD	015, 020	22	2		7780	9270	10800	12500
FGAH-A201-CFV, TFC, TFD	015, 020	407C	2		7840	9190	10600	12000
FJAM-A200-CFV, TFC	020	404A	2	6230	8530	9740	11000	12300
FJAM-A225-CFV, TFC, TFD	020	404A	2-1/4	7730	10100	11300	12500	13700
FGAH-A225-CFV, TFC, TFD	015, 020	22	2-1/4		8970	10500	12200	14000
FGAH-A225-CFV, TFC, TFD	015, 020	407C	2-1/4		9120	10700	12300	14000
FGAH-A301-CFV, TFC, TFD	015, 020	22	3		13100	15400	17800	20200
FGAH-A301-CFV, TFC, TFD	015, 020	407C	3		10900	13100	15300	17600
FJAM-A300-CFV, TFC, TFD	020	404A	3	9410	12800	14500	16300	18000
FGAH-A325-CFV, TFC, TFD	015, 020	22	3-1/4		14800	17200	19600	22000
FGAH-A325-CFV, TFC, TFD	015, 020	407C	3-1/4		11900	14300	16800	19300
FJAM-A325-CFV, TFC, TFD	020	404A	3-1/4	10100	13500	15400	17500	19800
FGAH-A401-CFV, TFC, TFD	015, 020	22	4		21100	24400	27800	31400
FGAH-A401-CFV, TFC, TFD	015, 020	407C	4		16800	20300	23900	27700
FJAM-B400-CFV, TFC, TFD	020	404A	4	15600	20500	23200	26100	29300
FGAH-A501-CFV, TFC, TFD, TFE	015, 020	22	5		24900	28900	33000	37100
FGAH-A501-CFV, TFC, TFD, TFE	015, 020	407C	5		24600	28500	32500	36600
FJAM-B500-CFV, TFC	020	404A	5	17700	23600	26600	29500	32300

Capacities are at 60 Hertz with 5°F subcooling.
HT models are rated at 65°F return gas temperature.
MT models are rated at 40°F return gas temperature

SystemPro® air-cooled condensing units

Capacity Data

HIGH/MED TEMP		Capacity (BTU/Hr) at 110° Ambient - Evaporator Temp (°F)					
Model	BOM	Refrig.	H.P.	+30	+35	+40	+45
M2FH-0017-SAA	111	134a	1/6	1070	1190	1320	1460
M2FH-0020-IAA	111	134a	1/5	1290	1430	1560	1690
MMFH-0022-IAA	111	22	1/5	1590	1740	1890	
M4FH-0022-IAA	111	404A	1/5	1610	1740		
M2FH-0024-SAA	111	134a	1/4	1740	1920		
M2FH-0026-IAA	072,111,103	134a	1/4	1910	2100		
MCFH-0027-IAA	111,103,272	22	1/4	2410			
M4FH-0025-IAA	103,272	404A	1/4	2190			
M2FH-A033-IAA, IAV	111,103,272	134a	1/3	2440	2720		
MCFH-0036-IAA	111,103,272	22	1/3	2930	3230	3550	
M4FH-A036-IAA, IAV	111,103,272	404A	1/3	3100	3390		
M2FH-0049-IAA, IAV	111,103,272	134a	1/2	3430			
MCFH-0049-CAA, CAV	111,103,272	22	1/2	4150	4550		
M2FH-0050-IAA-IAV	111,103,272	134a	1/2	4060			
M4FF-0050-IAA, IAV	212	404A	1/2				
M4FF-0056-IAA, IAV	103,212,272	404A	1/2				
M2FH-0056-IAA, IAV	111,103,272	134a	1/2	4450	4920		
MCFH-0056-IAA, IAV	111,103,272	22	1/2	4610	5140	5730	
M4FH-0050-CAA, CAV	111,103,272	404A	1/2	3850	4190		
FTAH-B074-IAA, IAV	212	134a	3/4	4850	5420		
FTAM-A075-IAA, IAV	020	134a	3/4				
F3AH-A078-IAA, IAV	020	22	3/4	5870	6520	7200	7890
M4FF-0075-CAA, CAV	020	404A	3/4				
FTAH-A101-CFV, TFC, TFD	020	134a	1	7080	8000		
F3AH-A100-CAV	020	22	1	6900	7650		
FJAF-0106-CAV	020	404A	1				
F3AM-A105-CFV, TFC	020	22	1				
FTAH-A125-CFV, TFC, TFD	020	134a	1-1/4	10100	11500	13000	14500
FJAM-A125-CFV, TFC	020	404A	1-1/4				
FJAM-A126-CAV, TFC	020	404A	1-1/4				
FTAH-A150-CFV, TFC, TFD	020	134a	1-1/2	11900	13500		
FGAH-A151-CFV, TFC, TFD	020	22	1-1/2	10200	11500		
FGAH-A151-CFV, TFC, TFD	020	407C	1-1/2	10400	11600	12900	14200
FJAM-A150-CFV, TFC, TFD	020	404A	1-1/2				
FTAH-A201-CFV, TFC, TFD	020	134a	2	14900	17100	19400	21800
FGAH-A201-CFV, TFC, TFD	015, 020	22	2	14300	16100	18100	
FGAH-A201-CFV, TFC, TFD	015, 020	407C	2	13600	15200	16900	18600
FJAM-A200-CFV, TFC	020	404A	2				
FJAM-A225-CFV, TFC, TFD	020	404A	2-1/4				
FGAH-A225-CFV, TFC, TFD	015, 020	22	2-1/4	15900	17900		
FGAH-A225-CFV, TFC, TFD	015, 020	407C	2-1/4	15700	17500	19500	21500
FGAH-A301-CFV, TFC, TFD	015, 020	22	3	22700	25300	28000	
FGAH-A301-CFV, TFC, TFD	015, 020	407C	3	20100	22700	25400	28300
FJAM-A300-CFV, TFC, TFD	020	404A	3				
FGAH-A325-CFV, TFC, TFD	015, 020	22	3-1/4	24600	27200		
FGAH-A325-CFV, TFC, TFD	015, 020	407C	3-1/4	22000	24800	27700	30900
FJAM-A325-CFV, TFC, TFD	020	404A	3-1/4				
FGAH-A401-CFV, TFC, TFD	015, 020	22	4	35200	39200	43300	47500
FGAH-A401-CFV, TFC, TFD	015, 020	407C	4	31600	35800	40300	45100
FJAM-B400-CFV, TFC, TFD	020	404A	4				
FGAH-A501-CFV, TFC, TFD, TFE	015, 020	22	5	41400	45800	50500	55200
FGAH-A501-CFV, TFC, TFD, TFE	015, 020	407C	5	40800	45100	49600	54200
FJAM-B500-CFV, TFC	020	404A	5				

Capacities are at 60 Hertz with 5°F subcooling.

HT models are rated at 65°F return gas temperature.

MT models are rated at 40°F return gas temperature

SystemPro® air-cooled condensing units

Physical/Electrical Data

HIGH/MED TEMP Model	Comp Model	Oil Type	Overall Dimensions (In)			Connecting Lines		Minimum Circuit Ampacity - Max Fuse Size				Pump Down Cap. (lbs)	Ship Wt. (lbs)
			L	W	H	Suction	Liquid	115-1-60	208/230-1	230-3	460-3		
M2FH-0017-SAA	ARB13C3E	POE	13.9	11.3	9.7	3/8 S	1/4 S	4.2 - 15					33
M2FH-0020-IAA	ARB17C3E	POE	13.8	11.3	9.7	3/8 S	1/4 S	5.2 - 15					41
MMFH-0022-IAA	ARB21C3	AB	13.8	11.3	9.7	3/8 S	1/4 S	6.5 - 15					37
M4FH-0022-IAA	ASB12C3E	POE	13.8	11.4	9.7	3/8 S	1/4 S	7.3 - 15					37
M2FH-0024-SAA	ARE25C3E	POE	13.8	11.8	9.7	3/8 S	1/4 S	6.9 - 15					36
M2FH-0026-IAA	ARE27C3E	POE	13.8	11.8	9.7	3/8 S	1/4 S	6.8 - 15				2-1/2	41
MCFH-0027-IAA	ARE36C3	AB	13.8	11.3	9.7	3/8 S	1/4 S	9.1 - 15				2.5	38
M4FH-0025-IAA	ASE19C3E	POE	13.8	11.8	9.7	3/8 S	1/4 S	10.7 - 15				2.2	43
M2FH-A033-IAA, IAV	ARE37C3E	POE	13.8	11.3	9.7	3/8 S	1/4 S	9.9 - 15	4.9 - 15			2.5	43
MCFH-0036-IAA	ARE43C3	AB	16.1	12.9	11.8	3/8 S	1/4 S	9.7 - 15				3.6	49
M4FH-A036-IAA, IAV	ASE24C3E	POE	16.1	12.7	11.8	3/8 S	1/4 S	8.4 - 15	5.9 - 15			3.3	44
M2FH-0049-IAA, IAV	ART51C1E	POE	16.2	12.7	11.8	3/8 S	1/4 S	12.5 - 20	6.85 - 15			3.7	56
MCFH-0049-CAA, CAV	ARE59C3A	AB	16.1	13.1	11.8	3/8 S	1/4 S	10.9 - 15	5.6 - 15			4.0	51
M2FH-0050-IAA-IAV	ART62C1E	POE	16.2	12.7	11.8	3/8 S	1/4 S	13.6 - 20	7.3 - 15			4.1	58
M4FF-0050-IAA, IAV	RST45C1E	POE	16.1	13.7	11.7	1/2 S	1/4 S	14 - 20	7.2 - 15			2.2	55
M4FF-0056-IAA, IAV	RST45C1E	POE	17.4	14.4	11.8	1/4 S	5/8 S	14.8 - 20	7.6 - 15			4.3	58
M2FH-0056-IAA, IAV	ART64C1E	POE	17.9	14.4	11.8	1/2 S	1/4 S	15.5 - 20	8.8 - 15			4.3	66
MCFH-0056-IAA, IAV	ART69C1	AB	17.4	14.4	11.8	3/8 S	1/4 S	18.0 - 25	9.6 - 15			4.1	69
M4FH-0050-CAA, CAV	ASE32C3E	POE	16.1	12.7	11.8	3/8 S	1/4 S	12.3 - 20	6.7 - 15			3.7	50
FTAH-B074-IAA, IAV	RR81C2E	POE	17.4	14.4	11.8	5/8 S	3/8 S	20.7 - 30	12.3 - 20			5.1	79
FTAM-A075-IAA, IAV	RS54C2E	POE	24.0	16.9	13.1	5/8 S	3/8 S	16.8 - 25	9.7 - 15			7.9	95
F3AH-A078-IAA, IAV	RS47C2	MIN	24.0	16.9	13.1	5/8 S	3/8 S	19.9 - 30	10.1 - 15			6.1	101
M4FF-0075-CAA, CAV	RST55C1E	POE	24.0	16.9	13.1	5/8 S	3/8 S	20.8 - 30	9.7 - 15			7.2	82
FTAH-A101-CFV, TFC, TFD	CS10K6E	POE	24.0	16.8	15.9	5/8 S	3/8 S		14.8 - 20	10.5 - 15	5.2 - 15	8.4	130
F3AH-A100-CAV	RRG4-0100	MIN	24.0	16.9	13.1	5/8 S	3/8 S		9.5 - 15			8.3	107
FJAF-0106-CAV	RST64C1E	POE	24.0	18.3	16.1	7/8 S	3/8 S	12.7 - 20				7.9	140
F3AM-A105-CFV, TFC	RS70C1	MIN	24.0	18.4	16.2	7/8 S	3/8 S		11.7 - 15			14.7	98
FTAH-A125-CFV, TFC, TFD	CS14K6E	POE	24.0	18.4	16.3	7/8 S	3/8 S		18.4 - 25	14.3 - 20	7.5 - 15	9.2	140
FJAM-A125-CFV, TFC	RS70C1E	POE	24.0	18.3	16.2	7/8 S	3/8 S		11.7 - 15	8.8 - 15		12.8	124
FJAM-A126-CAA, TFC	RS80C2E	POE	24.0	18.3	16.2	7/8 S	3/8 S		14.9 - 20	10.9 - 15		12.8	133
FTAH-A150-CFV, TFC, TFD	CS18K6E	POE	24.0	18.4	16.3	7/8 S	3/8 S		21.4 - 35	15.9 - 20	7.5 - 15	9.2	153
FGAH-A151-CFV, TFC, TFD	CR18KQE	POE	24.0	18.3	16.9	7/8 S	3/8 S		14.2 - 20	10.4 - 15	5.4 - 15	9.1	133
FGAH-A151-CFV, TFC, TFD	CR18KQE	POE	24.0	18.3	16.1	7/8 S	3/8 S		14.2 - 20	10.4 - 15	5.4 - 15		133
FJAM-A150-CFV, TFC, TFD	CS10K6E	POE	24.0	18.3	16.2	7/8 S	3/8 S		16.5 - 20	12.2 - 15	6.1 - 15	12.8	144
FTAH-A201-CFV, TFC, TFD	CS20K6E	POE	25.2	34.0	18.9	7/8 S	3/8 S		29.1 - 40	20.0 - 25	9.6 - 15	16.7	140
FGAH-A201-CFV, TFC, TFD	CR24KQE	POE	25.0	34.0	19.0	7/8 S	3/8 S		19.2 - 30	11.7 - 15	6.1 - 15	17.8	180
FGAH-A201-CFV, TFC, TFD	CR24KQE	POE	25.2	34.0	19.0	7/8 S	3/8 S		19.2 - 30	11.7 - 15	6.1 - 15		215
FJAM-A200-CFV, TFC	CS12K6E	POE	25.1	31.4	18.9	7/8 S	3/8 S		15.9 - 20	11.7 - 15		14.3	170
FJAM-A225-CFV, TFC, TFD	CS14K6E	POE	25.1	34.1	18.9	7/8 S	3/8 S		17.8 - 25	13.7 - 20	7.4 - 15	14.3	202
FGAH-A225-CFV, TFC, TFD	CR24KQE	POE	25.1	34.1	19.0	7/8 S	3/8 S		21.1 - 30	13.3 - 15	7.0 - 15	17.8	239
FGAH-A225-CFV, TFC, TFD	CR24KQE	POE	25.2	34	19.0	7/8 S	3/8 S		21.1 - 30	13.3 - 15	7.0 - 15		239
FGAH-A301-CFV, TFC, TFD	CR37KQE	POE	25.2	34.1	19.1	1-1/8 S	3/8 S		28.9 - 40	19.7 - 20	10.2 - 15	20.0	239
FGAH-A301-CFV, TFC, TFD	CR37KQE	POE	25.2	34	19	7/8 S	3/8 S		28.9 - 40	19.7 - 20	10.2 - 15		239
FJAM-A300-CFV, TFC, TFD	CS18K63	POE	25.1	34.1	19.4	1-1/8 S	3/8 S		25.8 - 35	18.8 - 20	9.1 - 15	16.3	217
FGAH-A325-CFV, TFC, TFD	CR41KQE	POE	25.2	34.1	18.9	1-1/8 S	3/8 S		30.1 - 40	22.2 - 25	10.6 - 15	20.0	239
FGAH-A325-CFV, TFC, TFD	CR41KQE	POE	25.2	34	19	7/8 S	3/8 S		30.1 - 40	22.2 - 25	10.6 - 15		239
FJAM-A325-CFV, TFC, TFD	CS20K6E	POE	25.1	34.1	18.9	1-1/8 S	3/8 S		29.1 - 40	20.1 - 25	9.6 - 15	16.3	224
FGAH-A401-CFV, TFC, TFD	CR53KQE	POE	28.2	44.1	26.9	1-1/8 S	1/2 S		39.9 - 60	26.1 - 40	13.8 - 20	31.5	306
FGAH-A401-CFV, TFC, TFD	CR53KQE	POE	24	18.3	16.1	7/8 S	3/8 S		39.9 - 60	26.1 - 40	13.8 - 20		306
FJAM-B400-CFV, TFC, TFD	CS27K6E	POE	28.2	44.1	26.9	1-1/8 S	1/2 S		33.5 - 50	23.1 - 35	12.0 - 15	27.3	373
FGAH-A501-CFV, TFC, TFD, TFE	CRKQ-050E	POE	28.6	44.1	26.9	1-1/8 S	1/2 S		46.5 - 70	30.4 - 45	14.4 - 20	31.5	337
FGAH-A501-CFV, TFC, TFD, TFE	CRKQ-050E	POE	28.6	44.1	26.9	1-1/8 S	1/2 S		46.5 - 70	30.4 - 45	14.4 - 20		337
FJAM-B500-CFV, TFC	CS33K3E	POE	28.2	44.1	26.8	1-1/8 S	1/2 S		42.0 - 60	27.0 - 40		27.3	295

F = Flare S = Sweat *TFE MCA-Max Fuse Size 11.9 - 15

SystemPro® air-cooled condensing units

Capacity Data

LOW TEMP		Capacity (BTU/Hr) at 90° Ambient - Evaporator Temp (°F)							
Model	BOM	Refrig.	H.P.	-30	-25	-20	-15	-10	0
M2FL-0023-IAA	111	134a	1/4		440	550	630	740	960
M4FL-0025-IAA	072, 111, 103	404A	1/4		610	710	810	920	1160
M2FL-A025-IAA	111,103,020	134a	1/4		720	820	940	1070	1370
M2FL-B033-IAA	111,103,020	134a	1/3		850	960	1040	1240	1590
M4FL-0033-IAA	072, 111, 103	404A	1/3		860	1040	1210	1390	1750
M2FL-0040-IAA	111,103,020	134a	1/3		920	1120	1320	1540	2010
M4FL-0040-IAA	111,103,272	404A	1/3		1320	1550	1790	2040	2560
FTAL-A050-IAA, IAV	111,103,212	134a	1/2		1280	1590	1910	2260	2980
M4FL-H051-IAA	111,103,272	404A	1/2		1460	1760	2080	2430	3160
M4FL-0067-CFA, CFV	111,103,272	404A	3/4		2190	2520	2890	3290	4200
FJAF-A075-CAA, IAV	020	404A	3/4		2110	2560	3020	3490	4400
FJAL-A101-CAV, TFC	020	404A	1		3160	3680	4240	4850	6170
FJAL-A103-CFV, TFC	020	404A	1	2380	2950	3570	4230	4950	6500
FJAL-B200-CFV, TFC, TFD	020	404A	2	4100	5040	6060	7130	8260	10500
FJAL-A225-CFV, TFC, TFD	020	404A	2-1/4	4350	5380	6510	7730	9010	11600
FJAL-B301-CFV, TFC, TFD	020	404A	3	6330	7830	9470	11200	13100	16900
FJAL-A390-CFV, TFC, TFD	015	404A	4	8700	10400	12200	14000	16000	20000

LOW TEMP		Capacity (BTU/Hr) at 100° Ambient - Evaporator Temp (°F)							
Model	BOM	Refrig.	H.P.	-30	-25	-20	-15	-10	0
M2FL-0023-IAA	111	134a	1/4		420	510	600	710	920
M4FL-0025-IAA	072, 111, 103	404A	1/4		560	640	740	840	1050
M2FL-A025-IAA	111,103,020	134a	1/4		670	760	870	1000	1280
M2FL-B033-IAA	111,103,020	134a	1/3		770	880	1000	1150	1480
M4FL-0033-IAA	072, 111, 103	404A	1/3		690	850	1010	1180	1530
M2FL-0040-IAA	111,103,020	134a	1/3		780	960	1150	1350	1810
M4FL-0040-IAA	111,103,272	404A	1/3		1100	1310	1530	1770	2240
FTAL-A050-IAA, IAV	111,103,212	134a	1/2		1050	1340	1640	1970	2660
M4FL-H051-IAA	111,103,272	404A	1/2		1240	1500	1790	2100	2770
M4FL-0067-CFA, CFV	111,103,272	404A	3/4		1960	2260	2590	2960	3770
FJAF-A075-CAA, IAV	020	404A	3/4		1770	2200	2620	3060	3920
FJAL-A101-CAV, TFC	020	404A	1		2720	3200	3720	4270	5470
FJAL-A103-CFV, TFC	020	404A	1	1930	2430	2970	3550	4180	5540
FJAL-B200-CFV, TFC, TFD	020	404A	2	3410	4250	5170	6140	7160	9170
FJAL-A225-CFV, TFC, TFD	020	404A	2-1/4	3610	4540	5560	6670	7840	10200
FJAL-B301-CFV, TFC, TFD	020	404A	3	5370	6700	8170	9750	11400	14900
FJAL-A390-CFV, TFC, TFD	015	404A	4	7280	8890	10500	12200	14000	17600

LOW TEMP		Capacity (BTU/Hr) at 110° Ambient - Evaporator Temp (°F)							
Model	BOM	Refrig.	H.P.	-30	-25	-20	-15	-10	0
M2FL-0023-IAA	111	134a	1/4		370	470	550	650	870
M4FL-0025-IAA	072, 111, 103	404A	1/4		500	570	660	750	930
M2FL-A025-IAA	111,103,020	134a	1/4			700	800	920	1190
M2FL-B033-IAA	111,103,020	134a	1/3			800	920	1050	1360
M4FL-0033-IAA	072, 111, 103	404A	1/3		520	670	830	990	1320
M2FL-0040-IAA	111,103,020	134a	1/3		600	780	970	1170	1630
M4FL-0040-IAA	111,103,272	404A	1/3		850	1060	1280	1500	1970
FTAL-A050-IAA, IAV	111,103,212	134a	1/2					1700	2350
M4FL-H051-IAA	111,103,272	404A	1/2		970	1210	1480	1770	2410
M4FL-0067-CFA, CFV	111,103,272	404A	3/4			2000	2310	2650	3410
FJAF-A075-CAA, IAV	020	404A	3/4			1840	2230	2630	3400
FJAL-A101-CAV, TFC	020	404A	1			2710	3180	3680	4740
FJAL-A103-CFV, TFC	020	404A	1	1510	1920	2370	2850	3380	4540
FJAL-B200-CFV, TFC, TFD	020	404A	2		3520	4310	5160	6060	7840
FJAL-A225-CFV, TFC, TFD	020	404A	2-1/4	2970	3760	4660	5640	6680	8840
FJAL-B301-CFV, TFC, TFD	020	404A	3	4470	5620	6910	8310	9820	12900
FJAL-A390-CFV, TFC, TFD	015	404A	4	5900	7400	8910	10400	12000	15300

Capacities are at 60 Hertz with 5°F subcooling
 LT models are rated at 40°F return gas temperature

NOTE: See appendix for Flex-Line hood information

2011DS-4_M&F (4/11)

SystemPro® air-cooled condensing units

Physical/Electrical Data

LOW TEMP Model	Comp Model	Oil Type	Overall Dimensions (In)			Connecting Lines		Minimum Circuit Ampacity - Max Fuse Size				Pump Down Cap. (lbs)	Ship Wt. (lbs)
			L	W	H	Suction	Liquid	115-1-60	208/230-1	230-3	460-3		
M2FL-0023-IAA	AFB05C3E	POE	13.8	11.3	9.7	3/8 S	1/4 S	4.2 - 15					36
M4FL-0025-IAA	AFB09C3E	POE	13.8	11.8	9.7	3/8 S	1/4 S	6.7 - 15				2.4	42
M2FL-A025-IAA	AFE10C3E	POE	13.8	11.3	9.7	3/8 S	1/4 S	6.9 - 15				2.5	35
M2FL-B033-IAA	AFE12C3E	POE	16.2	12.4	9.7	3/8 S	1/4 S	6.7 - 15				2.5	44
M4FL-0033-IAA	AFE11C3E	POE	13.8	12.0	9.7	3/8 S	1/4 S	7.7 - 15				2.2	44
M2FL-0040-IAA	AFT12C1E	POE	16.7	12.6	9.7	3/8 S	1/4 S	7.3 - 15				2.8	55
M4FL-0040-IAA	AFE13C3E	POE	16.2	13.1	11.8	3/8 S	1/4 S	8.9 - 15				3.1	52
FTAL-A050-IAA, IAV	RF18C2E	POE	16.0	13.3	11.9	1/2 S	1/4 S	17.2 - 25	9.5 - 15			3.6	69
M4FL-H051-IAA	AFE17C4E	POE	17.4	13.1	11.8	1/2 S	1/4 S	11.6 - 15				3.5	65
M4FL-0067-CFA, CFV	AFT26C1E	POE	18.1	14.4	11.8	1/2 S	1/4 S	12.7 - 15	6.8 - 15			3.8	65
FJAF-A075-CAA, IAV	RS64C2E	POE	24.0	16.1	13.1	5/8 S	3/8 S	21.0 - 30	12.7 - 20			4.8	89, 99
FJAL-A101-CAV, TFC	RS80C2E	POE	24.0	16.9	13.1	5/8 S	3/8 S		13.2 - 20	9.2 - 15		9.2	107
FJAL-A103-CFV, TFC	CF04K6E	POE	24.0	17.2	15.0	7/8 S	3/8 S		13.2 - 20	9.2 - 15		7.2	125
FJAL-B200-CFV, TFC, TFD	CF06K6E	POE	24.0	19.5	16.3	7/8 S	3/8 S		17.2 - 25	11.7 - 15	6.2 - 15	7.9	138
FJAL-A225-CFV, TFC, TFD	CF06K6E	POE	25.2	34.1	19.0	7/8 S	3/8 S		16.6 - 25	11.1 - 15	6.1 - 15	14.3	197
FJAL-B301-CFV, TFC, TFD	CF09K6E	POE	25.2	34.1	19.0	7/8 S	3/8 S		26.7 - 35	18.6 - 20	10.1 - 15	16.3	225
FJAL-A390-CFV, TFC, TFD	CF12K6E	POE	25.2	34.0	19.0	7/8 S	3/8 S		31.4 - 45	21.2 - 25	11.5 - 15	16.3	226

F = Flare S = Sweat

Unit Features

Flare BOM (Obsolete)	Sweat BOM	Suction Connections		Liquid Connections		Filter Drier	Sight Glass	Electrical Connections		Fan Cycle Control	Fan Guard	UL/UR
		Suction Valve	Suction Accumulator	Base Valve	Receiver s/Valve			Power Cord	BX Conduit			
105, 106	111	•		•				•				UR
109	103	•			•			•				UR
201	212	•			•						•	UR*
010	015	•	•		•					•	•	UL
001	020	•			•						•	UL
	072	•			•	•	•				•	UL
	272	•			•	•	•				•	UR

*These recognized models are identical to listed models less pressure control. Need for the control is to be evaluated in the end use application.

Control Data*

Horsepower	Voltage	Bill of Material	Crankcase Heater	Low Pressure Control	High/Low Pressure Control	Contactor	115 Volt Control Circuit Transformer
1/6 - 1/2	All	All	No	No	No	No	No
3/4	115 or 208/230 (1Ph)	-212	No	No	No	No	No
3/4	115 or 208/230 (1Ph)	-020	No	Yes	No	No	No
1	115 or 208/230 (1Ph)	-020	Yes ¹	Yes	As Required	No	No
1	208/230 (3Ph)	-020	Yes ¹		Yes	Yes	No
1-1/4 - 1-1/2	208/230 (1Ph)	All	No ²		Yes	No	No
1-1/4 - 1-1/2	208/230 (3Ph)	All	No ²		Yes	Yes	No
2 - 5	208/230 (1Ph)	All	Yes		Yes	Yes	No
2 - 5	208/230 (3Ph)	All	Yes		Yes	Yes	No
1 - 5	460 (3Ph)	All	Yes ¹		Yes	Yes	Yes

* This data applies to units listed in this brochure only.

¹ Except units using R compressor

² Except units using CS or CF compressor

Hood Specification Data

Emerson Part #	Mfg. Part #	External Dimensions (in.)			Internal Dimensions (in.)			Unit Size*
		L	W	H	L	W	H	
505-7066-00	N/A	24.3	20.2	18.7	22.5	18.4	15.0	1/2 Hp to 3/4 Hp
505-7066-01	N/A	30.3	23.5	22.7	28.5	22.2	19	3/4 Hp to 2 Hp
505-7066-02	N/A	32.3	38.3	22.7	30.6	37.1	24.0	2 Hp to 3 Hp
505-7066-03	N/A	35.3	48	34.7	33.6	46.2	30.7	4 Hp to 6 Hp
005-0882-03	CHO-13	35.5	24.0	25.0	34.5	24.0	21.0	
005-0882-05	CHO-16	46.5	38.0	38.0	45.5	38.0	33.0	
005-0882-06	CHO-17	42.5	74.0	48.5	41.5	74.0	40.5	

UL Listed for outdoor use * Specific model to hood cross reference should be used.

SystemPro® air-cooled condensing units

Hood Selection

Copeland® Model	Dimensions (in.)			Hood	Flex-Line Hood
	L	W	H		
SystemPro Air-Cooled					
M2FH-0017	13.8	11.8	9.7	005-0882-00 / -09	505-7066-00
M2FH-0026	13.8	11.8	9.7	005-0882-00 / -09	505-7066-00
M2FH-0033	13.8	11.8	9.7	005-0882-00 / -09	505-7066-00
M2FH-0056	17.4	14.4	11.8	005-0882-00 / -09	505-7066-00
M4FH-0025	13.8	11.8	9.7	005-0882-00 / -09	505-7066-00
M4FH-A036	16.1	12.7	11.8	005-0882-00 / -09	505-7066-00
M2FL-0020	13.8	11.1	9.7	005-0882-00 / -09	505-7066-00
M2FL-A025	13.8	11.8	9.7	005-0882-00 / -09	505-7066-00
M2FL-B033	16.2	12.4	9.7	005-0882-00 / -09	505-7066-00
M4FL-0040	16.2	13.1	11.8	005-0882-00 / -09	505-7066-00
M4FL-0051	17.4	13.1	11.8	005-0882-00 / -09	505-7066-00
M4FL-0067	18.1	14.4	11.8	005-0882-00 / -09	505-7066-00
MCFH-0027	13.8	11.8	9.7	005-0882-00 / -09	505-7066-00
MCFH-0036	16	12.9	11.8	005-0882-00 / -09	505-7066-00
MCFH-0056	17.5	14.3	11.8	005-0882-00 / -09	505-7066-00
M4FF-0056	17.5	14.3	12.1	005-0882-00 / -09	505-7066-00
M4FF-0080	24.0	16.9	13.1	005-0882-00 / -09	505-7066-01
FJAL-A101	24.0	16.9	13.1	005-0882-00 / -09	505-7066-01
FJAL-B200	24.0	19.5	16.3	005-0882-02 / -10	505-7066-01
FJAL-B301	25.2	34.1	19.0	005-0882-01 / -11	505-7066-02
FJAL-A390	25.2	34.1	19.0	005-0882-01 / -11	505-7066-02
FJAF-0106	24.0	18.3	16.2	005-0882-00 / -09	505-7066-01
FJAM-A200	25.2	34.1	18.9	005-0882-01 / -11	505-7066-02
FJAM-B400	28.2	44.1	26.9	005-0882-04	505-7066-03
FTAH-B074	17.4	14.4	11.8	005-0882-00 / -09	505-7066-00
FTAH-A101	24.0	16.8	15.9	005-0882-00 / -09	505-7066-01
FTAH-A150	24.0	18.4	16.3	005-0882-02 / -10	505-7066-01
FTAH-A201	25.2	34.0	18.9	005-0882-01 / -11	505-7066-02
FTAL-A050	16.0	13.3	11.9	005-0882-00 / -09	505-7066-00
FGAH-A151	24.1	18.3	16.9	005-0882-02 / -10	505-7066-01
FGAH-A201	25.0	34.0	19.0	005-0882-01 / -11	505-7066-02
FGAH-A301	25.0	34.0	19.0	005-0882-01 / -11	505-7066-02
FGAH-A401	28.6	44.1	26.9	005-0882-04	505-7066-03
FGAH-A501	28.6	44.1	26.9	005-0882-04	505-7066-03
F3AH-A078	24.0	16.9	13.1	005-0882-00 / -09	505-7066-01
F3AH-A100	24.0	16.9	13.1	005-0882-00 / -09	505-7066-01

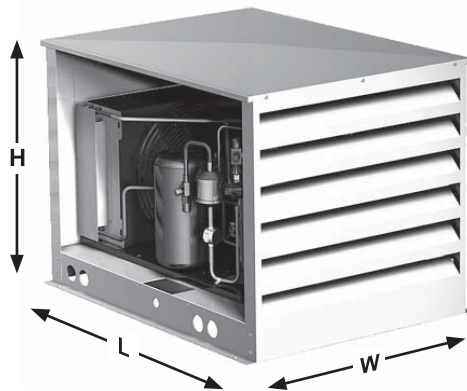

NOTE: See appendix for Flex-Line hood information
2011DS-4 _M&F (4/11)

Copeland Scroll®

Outdoor condensing units for refrigeration applications



Product Information

Horsepower:	1-1/2 – 6
Temperature Applications:	Low/Medium/High
Refrigerants:	R-404A
Installation Applications:	A variety of applications including walk-in boxes



Nomenclature • Welded Condensing Units

Temperature Application	Code
High Temperature	H
Medium Temperature	M
Low Temperature	L
Extended Medium Temp.	F
Extra Low Temperature	E
Multiple	S
Multiple	N

Compressor Motor Types		
Phase	Description	Code
1	Capacitor Run - Capacitor Start	C
1	Induction Run - Capacitor Start	I
1	Induction Run - Split Phase	S
1	Capacitor Run - Permanent Split	P
3	Three Phase - General	T
3	Star (Wye) Delta	E
3	6 Lead - Part Winding or Across the Line	F

Bill Of Material (BOM)	
001 thru 099	Intended for UL Listing and CUL Certified
100 thru 299	Intended for UL Recognition and CUL Certified
300 thru 399	Not eligible for either UL Listing, UL Recognition or CUL Certified

Type of Design	Code
Air Cooled Steel Base	A
Air Cooled Copevap Base	E/P
Narrow Air Cooled Copevap	T
Water Cooled Steel Base	W
Custom Base	C
Discus	D

Comp. Motor Rating	
Nominal HP	Code
1/2	0050
3/4	0075
1	0100
1-1/2	0150
2	0200
3	0300
4	0400
5	0500
6	0600
7-1/2	7500
9	0900
10	1000
15	1500

Compressor Motor Protection	
Type Protection	Code
External Inherent Protection - One Protector (Line Break)	A
Internal Inherent Protection - One Protector (Line Break)	F
Internal Thermal Protection - Electronic Sensors; and Control Module External	S

Electrical Codes		
60 Hz.	50 Hz.	Code
115-1	100-1	A
230-1	-	B
208/230-3	200/220-3	C
460-3	-	D
575-3	-	E
-	230-1	G
-	380/420-3	M
208/230-1	200-1	V
-	220-3	W
-	220/240-1	Z

Refrigerant	Code
R404A/507	J/4
R134a	T/2
R12	B
R22	C/3/M
Multiple	F
R22/407C	G
R22	9
R134a/404A/22	N
R134a/404A	P
R404A/22	8

X X X X - X X X X - X X X - X X X

Dimensional Drawings

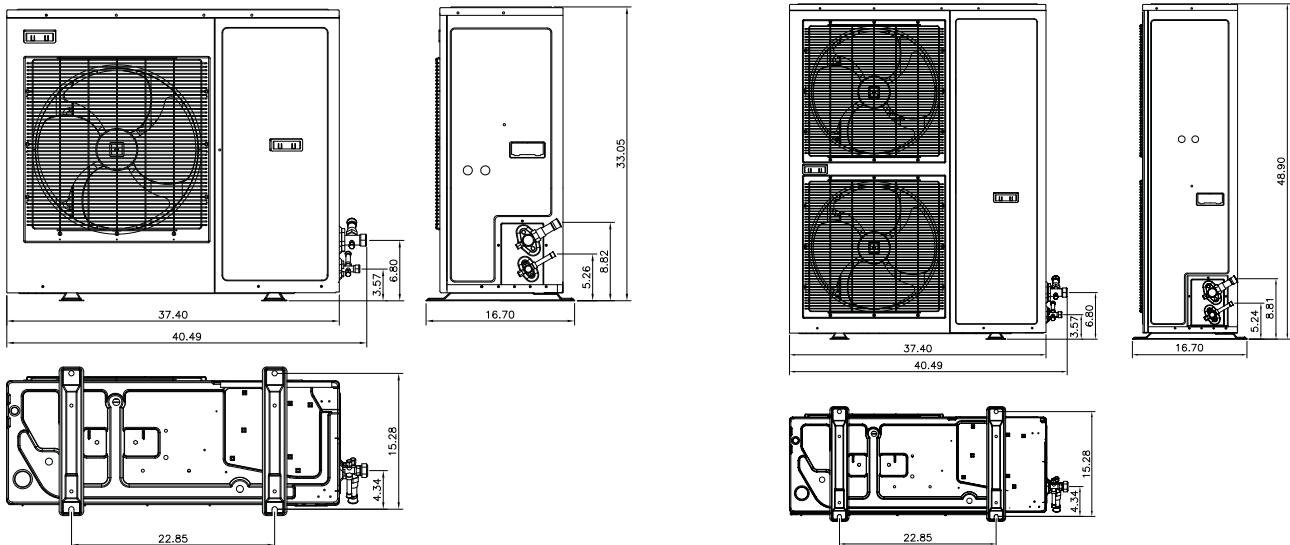

Copeland Scroll® outdoor condensing units

Features	Benefits
Copeland Scroll® Compressor Variable Speed Fan Motor	Reliability
	High Energy Efficiency
	Low Sound & Vibration
Advanced Diagnostics and Protection Features	Faster Troubleshooting Warranty Reduction
Factory Installed EK Filter Drier and HMI Moisture Indicator	Fewer Leaks, Reduced Callbacks, Lower Installation Costs, Increased Equipment Reliability, Lower Warranty
Slim Profile Design and Light Weight	Application Flexibility

Resources and Support

EmersonClimate.com

- Online Product Information and Technical Data
 - Application Engineering Bulletins
 - Instruction Sheets
 - Marketing Brochures
- Product Selection Tools
 - Walk-In Box Load Calculator
- Where to Buy

Application Engineering Bulletins

- 4-1273 Factors to Consider in Converting Compressor Rated Capacity to Actual Capacity
- 4-1327 Economized Vapor Injection (EVI) Compressors
- 11-1147 Suction Accumulators
- 11-1297 Liquid Line Filter Driers
- 17-1260 Compressor Overheating
- 17-1268 Compression Ratio as it Affects Compressor Reliability
- 22-1182 Liquid Refrigerant Control in Refrigeration and Air Conditioning Systems

2009IP-43 **Copeland Scroll Outdoor Condensing Unit Installation and Reference Manual** is provided with each unit and is a source for additional product details.

2007IP-52 **Refrigeration Load Calculator** software is available to compute refrigeration loads and select matching components. Contact your Emerson sales manager for more details.

For more information, visit EmersonClimate.com and login to the Customer Portal to view Online Product Information

Copeland Scroll® outdoor condensing units

Capacity Data

MED TEMP Capacity (BTU/Hr) at 90° Ambient - Evaporator Temp (°F)								
Model	Compressor	Refrig.	H.P.	-5	0	+5	+10	+15
XJAM-015Z-CFV	ZB11KCE	404A	1-1/2	7800	8500	9700	10800	12000
XJAM-020Z-CFV, TFC	ZX15KCE	404A	2	10570	11780	13140	14610	16160
XJAM-030Z-CFV, TFC	ZX21KCE	404A	3	15540	17900	19320	21570	23790
XJAM-040Z-CFV, TFC	ZX30KCE	404A	4	21280	23920	26450	28030	32400
XJAM-050Z-CFV, TFC	ZX38KCE	404A	5	26690	29600	32740	35910	39400
XJAM-060Z-TFC	ZX45KCE	404A	6	30360	33830	37780	41780	45890

MED TEMP Capacity (BTU/Hr) at 95° Ambient - Evaporator Temp (°F)								
Model	Compressor	Refrig.	H.P.	-5	0	+5	+10	+15
XJAM-015Z-CFV	ZB11KCE	404A	1-1/2	7450	8100	9300	10400	11600
XJAM-020Z-CFV, TFC	ZX15KCE	404A	2		11900	12600	14000	15600
XJAM-030Z-CFV, TFC	ZX21KCE	404A	3		16800	18500	20600	22800
XJAM-040Z-CFV, TFC	ZX30KCE	404A	4	20400	22800	25300	27500	31000
XJAM-050Z-CFV, TFC	ZX38KCE	404A	5	25600	28500	31500	34600	38000
XJAM-060Z-TFC	ZX45KCE	404A	6	29000	32400	36100	39900	44000

MED TEMP Capacity (BTU/Hr) at 100° Ambient - Evaporator Temp (°F)								
Model	Compressor	Refrig.	H.P.	-5	0	+5	+10	+15
XJAM-015Z-CFV	ZB11KCE	404A	1-1/2	7100	7800	8900	10000	11200
XJAM-020Z-CFV, TFC	ZX15KCE	404A	2		10730	11970	13360	15070
XJAM-030Z-CFV, TFC	ZX21KCE	404A	3		15780	17700	19670	21700
XJAM-040Z-CFV, TFC	ZX30KCE	404A	4	19440	21770	24210	26920	29620
XJAM-050Z-CFV, TFC	ZX38KCE	404A	5	24580	27480	30340	33360	36630
XJAM-060Z-TFC	ZX45KCE	404A	6	27730	31000	34500	38110	42040

MED TEMP Capacity (BTU/Hr) at 110° Ambient - Evaporator Temp (°F)								
Model	Compressor	Refrig.	H.P.	-5	0	+5	+10	+15
XJAM-015Z-CFV	ZB11KCE	404A	1-1/2	6330	7220	7900	8100	9600
XJAM-020Z-CFV, TFC	ZX15KCE	404A	2			10940	12170	13600
XJAM-030Z-CFV, TFC	ZX21KCE	404A	3				17540	19850
XJAM-040Z-CFV, TFC	ZX30KCE	404A	4			21910	24400	26830
XJAM-050Z-CFV, TFC	ZX38KCE	404A	5		24980	27860	30650	33540
XJAM-060Z-TFC	ZX45KCE	404A	6	23370	27280	31410	34800	38390

Copeland Scroll® outdoor condensing units

Capacity Data

MED TEMP Capacity (BTU/Hr) at 90° Ambient - Evaporator Temp (°F)								
Model	Compressor	Refrig.	H.P.	+20	+25	+30	+35	+40
XJAM-015Z-CFV	ZB11KCE	404A	1-1/2	13100	14600	16100	17500	19000
XJAM-020Z-CFV, TFC	ZX15KCE	404A	2	17770	19560	20800	22300	23790
XJAM-030Z-CFV, TFC	ZX21KCE	404A	3	26070	28490	30340	32470	34600
XJAM-040Z-CFV, TFC	ZX30KCE	404A	4	35500	38640	41060	43960	46860
XJAM-050Z-CFV, TFC	ZX38KCE	404A	5	43180	47070	49930	53330	56720
XJAM-060Z-TFC	ZX45KCE	404A	6	50320	54610	58340	62410	66470

MED TEMP Capacity (BTU/Hr) at 95° Ambient - Evaporator Temp (°F)								
Model	Compressor	Refrig.	H.P.	+20	+25	+30	+35	+40
XJAM-015Z-CFV	ZB11KCE	404A	1-1/2	12700	14100	15500	16900	18200
XJAM-020Z-CFV, TFC	ZX15KCE	404A	2	17200	18800	20100	21600	23100
XJAM-030Z-CFV, TFC	ZX21KCE	404A	3	25000	27200	29100	31200	33300
XJAM-040Z-CFV, TFC	ZX30KCE	404A	4	34000	37000	39400	42200	45000
XJAM-050Z-CFV, TFC	ZX38KCE	404A	5	41600	45400	48200	51500	54800
XJAM-060Z-TFC	ZX45KCE	404A	6	48200	52400	55900	59800	63700

MED TEMP Capacity (BTU/Hr) at 100° Ambient - Evaporator Temp (°F)								
Model	Compressor	Refrig.	H.P.	+20	+25	+30	+35	+40
XJAM-015Z-CFV	ZB11KCE	404A	1-1/2	12300	13600	14900	16200	17500
XJAM-020Z-CFV, TFC	ZX15KCE	404A	2	16640	17930	19460	20930	22410
XJAM-030Z-CFV, TFC	ZX21KCE	404A	3	23990	25880	27920	29960	32000
XJAM-040Z-CFV, TFC	ZX30KCE	404A	4	32430	35330	37730	40380	43040
XJAM-050Z-CFV, TFC	ZX38KCE	404A	5	40040	43760	46450	49630	52800
XJAM-060Z-TFC	ZX45KCE	404A	6	45970	50180	53480	57230	60970

MED TEMP Capacity (BTU/Hr) at 110° Ambient - Evaporator Temp (°F)								
Model	Compressor	Refrig.	H.P.	+20	+25	+30	+35	+40
XJAM-015Z-CFV	ZB11KCE	404A	1-1/2	11000	12100	13300	14400	15600
XJAM-020Z-CFV, TFC	ZX15KCE	404A	2	14940	16380	17700	19060	20430
XJAM-030Z-CFV, TFC	ZX21KCE	404A	3	21800	23340	25470	27410	29340
XJAM-040Z-CFV, TFC	ZX30KCE	404A	4	29490	32180	34650	37120	39780
XJAM-050Z-CFV, TFC	ZX38KCE	404A	5	36370	39820	42470	45400	48330
XJAM-060Z-TFC	ZX45KCE	404A	6	42200	45860	49660	53380	57110

Copeland Scroll® outdoor condensing units

Capacity Data

LOW TEMP		Capacity (BTU/Hr) at 90° Ambient - Evaporator Temp (°F)						
Model	Compressor	Refrig.	H.P.	-40	-35	-30	-25	-20
XJAL-020Z-CFV, TFC	ZXI06KCE	404A	2	5700	6960	8210	9450	10690
XJAL-030Z-TFC	ZXI09KCE	404A	3	7840	9390	10950	12500	14060
XJAL-035Z-CFV	ZXI11KCE	404A	3-1/2	9700	11100	12600	14200	15900
XJAL-040Z-CFV, TFC	ZXI14KCE	404A	4	12690	14430	16280	18240	20300
XJAL-050Z-TFC	ZXI15KCE	404A	5	14030	16040	18140	20350	22660
XJAL-050Z-CFV	ZXI16KCE	404A	5	14030	16040	18140	20350	22660
XJAL-060Z-TFC	ZXI18KCE	404A	6	18000	20500	23000	25700	28600

LOW TEMP		Capacity (BTU/Hr) at 95° Ambient - Evaporator Temp (°F)						
Model	Compressor	Refrig.	H.P.	-40	-35	-30	-25	-20
XJAL-020Z-CFV, TFC	ZXI06KCE	404A	2	5670	6900	8120	9330	10500
XJAL-030Z-TFC	ZXI09KCE	404A	3	7390	8960	10500	12100	13700
XJAL-035Z-CFV	ZXI11KCE	404A	3-1/2	9400	10700	12200	13700	15300
XJAL-040Z-CFV, TFC	ZXI14KCE	404A	4	12500	14200	16000	17900	19900
XJAL-050Z-TFC	ZXI15KCE	404A	5	13600	15500	17500	19700	21900
XJAL-050Z-CFV	ZXI16KCE	404A	5	13600	15500	17500	19700	21900
XJAL-060Z-TFC	ZXI18KCE	404A	6	17500	20000	22300	25000	27600

LOW TEMP		Capacity (BTU/Hr) at 100° Ambient - Evaporator Temp (°F)						
Model	Compressor	Refrig.	H.P.	-40	-35	-30	-25	-20
XJAL-020Z-CFV, TFC	ZXI06KCE	404A	2	5640	6840	8020	9200	10370
XJAL-030Z-TFC	ZXI09KCE	404A	3	6940	8520	10100	11680	13260
XJAL-035Z-CFV	ZXI11KCE	404A	3-1/2	9090	10300	11700	13100	14700
XJAL-040Z-CFV, TFC	ZXI14KCE	404A	4	12370	13980	15710	17540	19480
XJAL-050Z-TFC	ZXI15KCE	404A	5	13110	14960	16900	18940	21080
XJAL-050Z-CFV	ZXI16KCE	404A	5	13110	14960	16900	18940	21080
XJAL-060Z-TFC	ZXI18KCE	404A	6	17240	19480	21930	24380	27030

LOW TEMP		Capacity (BTU/Hr) at 110° Ambient - Evaporator Temp (°F)						
Model	Compressor	Refrig.	H.P.	-40	-35	-30	-25	-20
XJAL-020Z-CFV, TFC	ZXI06KCE	404A	2	5500	6610	7710	8810	9890
XJAL-030Z-TFC	ZXI09KCE	404A	3	5830	7420	9010	10590	12180
XJAL-035Z-CFV	ZXI11KCE	404A	3-1/2	9020	10140	11340	12720	14200
XJAL-040Z-CFV, TFC	ZXI14KCE	404A	4	11850	13350	14950	16660	18480
XJAL-050Z-TFC	ZXI15KCE	404A	5	11920	13590	15370	17250	19220
XJAL-050Z-CFV	ZXI16KCE	404A	5	11920	13590	15370	17250	19220
XJAL-060Z-TFC	ZXI18KCE	404A	6	16170	18330	20500	22760	25130

Copeland Scroll® outdoor condensing units

Capacity Data

LOW TEMP		Capacity (BTU/Hr) at 90° Ambient - Evaporator Temp (°F)					
Model	Compressor	Refrig.	H.P.	-15	-10	-5	0
XJAL-020Z-CFV, TFC	ZXI06KCE	404A	2	11920	13140	14360	15570
XJAL-030Z-TFC	ZXI09KCE	404A	3	15620	17170	18730	20280
XJAL-035Z-CFV	ZXI11KCE	404A	3-1/2	17700	19700	21700	23900
XJAL-040Z-CFV, TFC	ZXI14KCE	404A	4	22470	24740	27120	29610
XJAL-050Z-TFC	ZXI15KCE	404A	5	25060	27570	30170	32880
XJAL-050Z-CFV	ZXI16KCE	404A	5	25060	27570	30170	32880
XJAL-060Z-TFC	ZXI18KCE	404A	6	31600	34700	38100	41500

LOW TEMP		Capacity (BTU/Hr) at 95° Ambient - Evaporator Temp (°F)					
Model	Compressor	Refrig.	H.P.	-15	-10	-5	0
XJAL-020Z-CFV, TFC	ZXI06KCE	404A	2	11700	12900	14100	15300
XJAL-030Z-TFC	ZXI09KCE	404A	3	15200	16800	18400	19900
XJAL-035Z-CFV	ZXI11KCE	404A	3-1/2	17000	18900	20900	22900
XJAL-040Z-CFV, TFC	ZXI14KCE	404A	4	22000	24200	26500	29000
XJAL-050Z-TFC	ZXI15KCE	404A	5	24200	26600	29100	31800
XJAL-050Z-CFV	ZXI16KCE	404A	5	24200	26600	29100	31800
XJAL-060Z-TFC	ZXI18KCE	404A	6	30700	33700	37000	39900

LOW TEMP		Capacity (BTU/Hr) at 100° Ambient - Evaporator Temp (°F)					
Model	Compressor	Refrig.	H.P.	-15	-10	-5	0
XJAL-020Z-CFV, TFC	ZXI06KCE	404A	2	11530	12680	13830	14970
XJAL-030Z-TFC	ZXI09KCE	404A	3	14840	16420	18000	19580
XJAL-035Z-CFV	ZXI11KCE	404A	3-1/2	16300	18100	20000	21900
XJAL-040Z-CFV, TFC	ZXI14KCE	404A	4	21530	23680	25940	28300
XJAL-050Z-TFC	ZXI15KCE	404A	5	23320	25660	28100	30640
XJAL-050Z-CFV	ZXI16KCE	404A	5	23320	25660	28100	30640
XJAL-060Z-TFC	ZXI18KCE	404A	6	29780	32740	35800	38200

LOW TEMP		Capacity (BTU/Hr) at 110° Ambient - Evaporator Temp (°F)					
Model	Compressor	Refrig.	H.P.	-15	-10	-5	0
XJAL-020Z-CFV, TFC	ZXI06KCE	404A	2	10970	12040	13100	14160
XJAL-030Z-TFC	ZXI09KCE	404A	3	13770	15350	16940	18530
XJAL-035Z-CFV	ZXI11KCE	404A	3-1/2	15690	17380	19190	21090
XJAL-040Z-CFV, TFC	ZXI14KCE	404A	4	20400	22420	24560	26800
XJAL-050Z-TFC	ZXI15KCE	404A	5	21300	23470	25740	28110
XJAL-050Z-CFV	ZXI16KCE	404A	5	21300	23470	25740	28110
XJAL-060Z-TFC	ZXI18KCE	404A	6	27600	30200	32960	34700

Copeland Scroll® outdoor condensing units

Physical/Electrical Data

MED TEMP Model (Coolers)	Refrig.	Comp	H.P.	Overall Dimensions (in)			Connecting Lines (in)		# of Fans	Minimum Circuit Ampacity - Max Fuse Size		Pump Down Capacity (lbs)	Ship Weight (lbs)
				L	W	H	Suction	Liquid		208/230-1-60	208/230-3-60		
XJAM-015Z	404A	ZB11KCE	1-1/2	16.7	40.5	33.1	3/4	1/2	1	12.3/20		7.5	180
XJAM-020Z	404A	ZX15KCE	2	16.7	40.5	33.1	3/4	1/2	1	18.7 / 30	11.1 / 15	7.5	182
XJAM-030Z	404A	ZX21KCE	3	16.7	40.5	33.1	3/4	1/2	1	24.3 / 40	14.7 / 25	7.5	194
XJAM-040Z	404A	ZX30KCE	4	16.7	40.5	48.9	7/8	1/2	2	32.1 / 50	19.7 / 30	11	250
XJAM-050Z	404A	ZX38KCE	5	16.7	40.5	48.9	7/8	1/2	2	36.6 / 60	29.0 / 50	11	258
XJAM-060Z	404A	ZX45KCE	6.0	16.7	40.5	48.9	7/8	1/2	2		28.1 / 45	11	270

LOW TEMP Model (Freezers)	Refrig.	Comp	H.P.	Overall Dimensions (in)			Connecting Lines (in)		# of Fans	Minimum Circuit Ampacity - Max Fuse Size		Pump Down Capacity (lbs)	Ship Weight (lbs)
				L	W	H	Suction	Liquid		208/230-1-60	208/230-3-60		
XJAL-020Z	404A	ZXI06KCE	2	16.7	40.5	33.1	3/4	1/2	1	19.4 / 30	14.7 / 25	7.5	188
XJAL-030Z	404A	ZXI09KCE	3	16.7	40.5	33.1	3/4	1/2	1		15.4 / 25	7.5	192
XJAL-035Z	404A	ZXI11KCE	3-1/2	16.7	40.5	33.1	7/8	1/2	1	30.7 / 50		7.5	213
XJAL-040Z	404A	ZXI14KCE	4	16.7	40.5	48.9	7/8	1/2	2	36.1 / 60	24.5 / 40	11	251
XJAL-050Z	404A	ZXI15KCE	5	16.7	40.5	48.9	7/8	1/2	2		26.1 / 45	11	267
XJAL-050Z	404A	ZXI16KCE	5	16.7	40.5	48.9	7/8	1/2	2	40.4 / 70		11	287
XJAL-060Z	404A	ZXI18KCE	6.0	16.7	40.5	48.9	7/8	1/2	2		30.7 / 50	11	291

Correction Factor	Refrigerant Liquid Temperature °F															
	0	10	20	30	40	50	60	70	80	90	100	110	120	130	140	
R-12	1.60	1.54	1.48	1.42	1.36	1.30	1.24	1.18	1.12	1.06	1.00	.94	.88	.82	.75	
R-134a	1.70	1.63	1.56	1.49	1.42	1.36	1.29	1.21	1.14	1.07	1.00	.93	.85	.78	.71	
R-22	1.56	1.51	1.45	1.40	1.34	1.29	1.23	1.17	1.12	1.06	1.00	.94	.88	.82	.76	
R-404A/R-507	2.00	1.90	1.80	1.70	1.60	1.50	1.40	1.30	1.20	1.10	1.00	.90	.80	.70	.50	

Product Features	XJAM	XJAL
Hood	✓	✓
Elevated Legs	✓	✓
Variable-Speed PSC Fan	✓	✓
Brass Service Valves	✓	✓
Receiver	✓	✓
Liquid Shut-off Valve	✓	✓
Moisture Indicator	✓	✓
Filter Drier	✓	✓
Fixed HP	✓	✓
Adjustable LP	✓	✓
CCH	✓	✓
Diagnostics	✓	✓
Accumulator		✓
Oil Separator		✓
Defrost Timer	•	✓
One Way Communication	•	•

- ✓ Standard on -002 and -012 models
- Standard on -012 models only

Sound Data

	Model	dBa*
MED TEMP	XJAM-015Z	55
	XJAM-020Z	55
	XJAM-030Z	55
	XJAM-040Z	58
	XJAM-050Z	58
	XJAM-060Z	58
LOW TEMP	XJAL-020Z	53
	XJAL-030Z	53
	XJAL-035Z	53
	XJAL-040Z	59
	XJAL-050Z	59
	XJAL-060Z	59

Sound pressure values are 10 feet from the unit at 25°F evap for MT and -10°F evap for LT at 90°F ambient. A sound reduction of up to 3 dBA will occur in ambient temperatures below 70°F. This data is typical of “free field” conditions for horizontal air cooled condensing units and may vary depending on the condensing unit installation. There are many factors that affect the sound reading of a condensing unit such as unit mounting, reflecting walls, background noise and operating condition.

F and D Line

Copeland Scroll® air-cooled condensing units

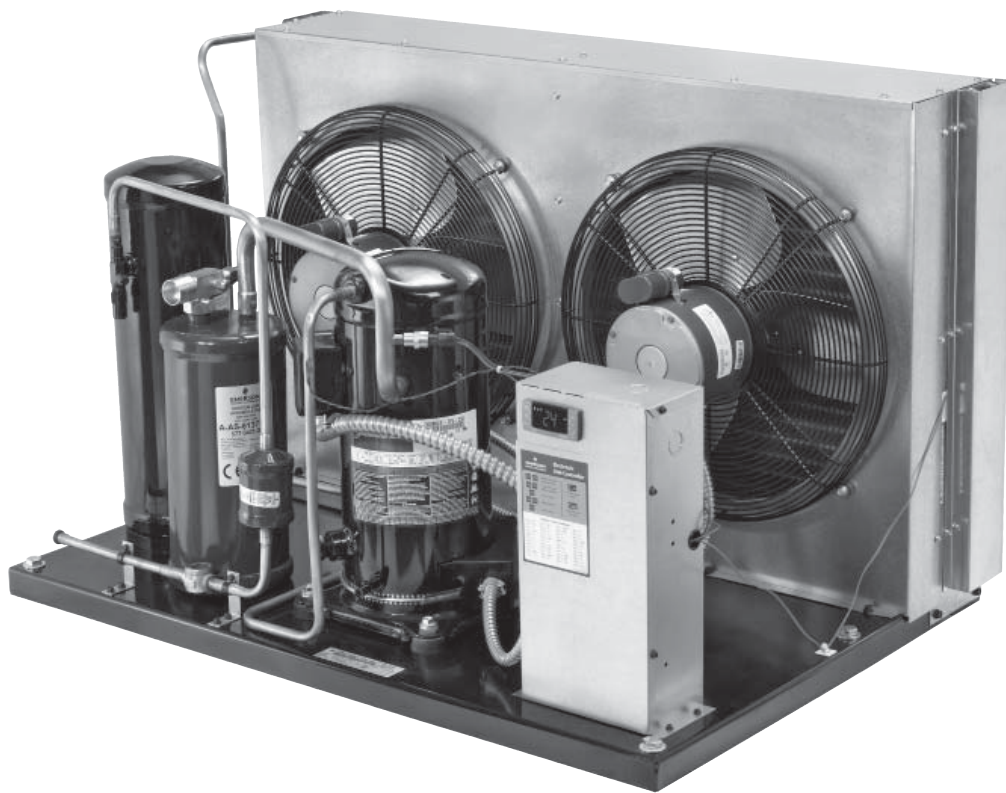

Product Information

Horsepower:	1 – 10
Temperature Applications:	Low/Medium/High
Refrigerants:	R-134a, R-404A, R-22, R-407C
Installation Applications:	A variety of applications including bulk milk and walk-in boxes



Nomenclature • Welded Condensing Units

Temperature Application	Code
High Temperature	H
Medium Temperature	M
Low Temperature	L
Extended Medium Temp.	F
Extra Low Temperature	E
Multiple	S
Multiple	N

Compressor Motor Types		
Phase	Description	Code
1	Capacitor Run - Capacitor Start	C
1	Induction Run - Capacitor Start	I
1	Induction Run - Split Phase	S
1	Capacitor Run - Permanent Split	P
3	Three Phase - General	T
3	Star (Wye) Delta	E
3	6 Lead - Part Winding or Across the Line	F

Bill Of Material (BOM)	
001 thru 099	Intended for UL Listing and CUL Certified
100 thru 299	Intended for UL Recognition and CUL Certified
300 thru 399	Not eligible for either UL Listing, UL Recognition or CUL Certified

Condensing Unit Family Series

Type of Design	Code
Air Cooled Steel Base	A
Air Cooled Copevap Base	E/P
Narrow Air Cooled Copevap	T
Water Cooled Steel Base	W
Custom Base	C
Discus	D

Comp. Motor Rating	
Nominal HP	Code
1/2	0050
3/4	0075
1	0100
1-1/2	0150
2	0200
3	0300
4	0400
5	0500
6	0600
7-1/2	7500
9	0900
10	1000
15	1500

Compressor Motor Protection	
Type Protection	Code
External Inherent Protection - One Protector (Line Break)	A
Internal Inherent Protection - One Protector (Line Break)	F
Internal Thermal Protection - Electronic Sensors; and Control Module External	S

Electrical Codes		
60 Hz.	50 Hz.	Code
115-1	100-1	A
230-1	-	B
208/230-3	200/220-3	C
460-3	-	D
575-3	-	E
-	230-1	G
-	380/420-3	M
208/230-1	200-1	V
-	220-3	W
-	220/240-1	Z

Refrigerant	Code
R404A/507	J/4
R134a	T/2
R12	B
R22	C/3/M
Multiple	F
R22/407C	G
R22	9
R134a/404A/22	N
R134a/404A	P
R404A/22	8

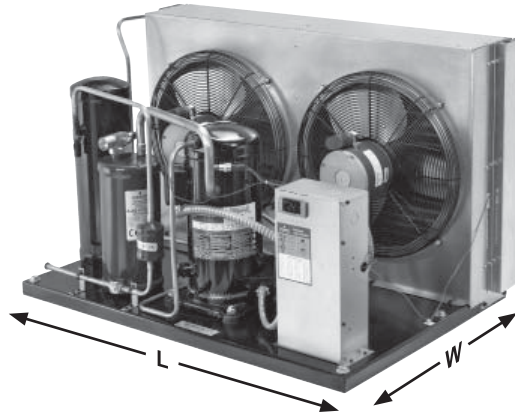

BOM	Suction Valve*	Suction Accumulator	Receiver	BX Conduit	Fan Guard	Discharge-Line T'stat	High/ Low Pressure Control	Time Delay Relay (1 Ø)	Filter Drier	Moisture Indicator	Liquid Solenoid Valve w/Coil	Fan Cycle Control
-015	•		•	•	•	•	•	•				•
-020	•		•	•	•	•	•	•				•
-071	•		•	•	•	•	•	•		•		•
-072	•		•	•	•	•	•	•		•		•
-073	•		•	•	•	•	•	•		•	•	•
-074	•		•	•	•	•	•	•		•	•	•
-081**	•	•	•	•	•	•	•	•		•		•
-172	•		•	•	•	•	•	•		•		•
-174	•		•	•	•	•	•	•		•	•	•

* except 1-1/2 HP

** includes factory installed Copeland PerformanceAlert™ module

BOM (bills of material) numbers apply only to the units listed in this section. All Models are UL Listed. UL/UR are registered trademarks of Underwriters Laboratories, Inc.

Copeland Scroll® air-cooled condensing units

Features	Benefits
Copeland Scroll® Compressor	Reliability
	High Energy Efficiency
	Low Sound & Vibration
Advance Diagnostics and Protection Features	Faster Trouble Shooting Warranty Reduction
Factory Installed EK Filter Drier & HMI Moisture Indicator	Less Leaks, Reduce Callbacks, Lower Installation Cost, Increase Equipment Reliability, Lower Warranty
Modular Components	Replacement Serviceability
Multi Refrigerant Approval for High/Med Models	Application Flexibility Inventory Consolidation

Resources and Support

EmersonClimate.com

■ Online Product Information and Technical Data

- Application Engineering Bulletins
- Instruction Sheets
- Marketing Brochures

■ Product Selection Tools

- Walk-In Box Load Calculator

■ Where to Buy

Optional Hood (refer to appendix of this catalog or form number 2010ECT-121 for more information)

Application Engineering Bulletins

- 4-1273 Factors to Consider in Converting Compressor Rated Capacity to Actual Capacity
- 4-1299 Application Guidelines for Copeland Scroll Compressors 2 - 6 Horsepower
- 4-1302 Application Guidelines for Copeland Scroll Compressors 7.5 - 15 Horsepower
- 4-1317 Application Guidelines for ZBKC / ZBKCE Refrigeration Scroll Compressors 1.3 to 6 HP
- 4-1318 Application Guidelines for ZBKC / ZBKCE Refrigeration Scroll Compressors 7 to 15 HP
- 8-1347 Copeland PerformanceAlert™ Diagnostic Module
- 11-1147 Suction Accumulators
- 11-1297 Liquid Line Filter-Driers
- 17-1260 Compressor Overheating
- 17-1268 Compression Ratio as it Affects Compressor Reliability
- 22-1182 Liquid Refrigerant Control in Refrigeration and Air Conditioning Systems

For more information, visit EmersonClimate.com and login to the Customer Portal to view Online Product Information

Copeland Scroll® air-cooled condensing units

Capacity Data

HIGH/MED TEMP		Capacity (BTU/Hr) at 90° Ambient - Evaporator Temp (°F)						
Model	BOM	Refrig.	H.P.	-5	0	+5	+10	+15
FTAH-A13Z-CFV,TFC,TFD	072, 074	134a	1			7090	8030	9030
FJAM-A15Z-CFV	172, 174	404A	1-1/2	6910	7730	8680	9620	10600
FFAS-A20Z-CFV, TFC	081	22	2					14300
		134a	2			7560	8570	9680
		404A	2	10200	11200	12400	13600	14800
		407C	2				11600	12900
FFAS-A25Z-CFV, TFC	081	22	2-1/2				15000	16800
		134a	2-1/2			8880	10100	11400
		404A	2-1/2	13100	14500	16100	17700	19400
		407C	2-1/2				13200	14900
FFAS-A30Z-CFV, TFC	081	22	3					21200
		134a	3			11000	12500	14100
		404A	3	15400	17000	18800	20700	22600
		407C	3				17200	19200
FFAS-A35Z-CFV, TFC	081	22	3-1/2					24200
		134a	3-1/2			12600	14300	16100
		404A	3-1/2	17600	19300	21400	23500	25700
		407C	3-1/2					22300
FFAS-A40Z-CFV, TFC	081	22	4				26800	29800
		134a	4			15300	17300	19600
		404A	4	21300	23600	26200	28900	31800
		407C	4				23900	26700
FFAS-A50Z-CFV, TFC, TFD	081	22	5				32400	36000
		134a	5			18500	21000	23800
		404A	5	26100	28900	32000	35200	38600
		407C	5				30500	34000
FFAS-A60Z-TFC, TFD	081	22	6					42300
		134a	6			22100	24900	28000
		404A	6	30400	33700	37200	40900	44700
		407C	6				34400	38400
FPAN-070Z-TFC,TFD	071, 073	134a	7			25700	29000	32500
		404A	7		38200	42700	47300	52100
FPAN-080Z-TFC,TFD	071,073	134a	8			28600	32200	36000
		404A	8		42200	47200	52300	57600
FPAN-091Z-TFC, TFD	071, 073	134a	9			32100	36000	40200
		404A	9		48800	54000	59200	64700
FPAN-101Z-TFC,TFD	071, 073	134a	10			37000	41500	46400
		404A	10		56800	62500	68200	74100
LOW TEMP		Capacity (BTU/Hr) at 90° Ambient - Evaporator Temp (°F)						
Model	BOM	Refrig.	H.P.				-40	-35
DJAL-015Z-CFV, TFC	081	404A	1-1/2				4750	5460
DJAL-020Z-CFV, TFC	081	404A	2				6040	6870
DJAL-022Z-CFV, TFC	081	404A	2+				6680	7580
DJAL-026Z-CFV, TFC	081	404A	2-1/2				8420	9580
DJAL-030Z-CFV, TFC	081	404A	3				9280	10600
DJAL-041Z-CFV,TFC,TFD	081	404A	4				12000	13700
DJAL-051Z-TFC, TFD	081	404A	5				14300	16300
DJAL-060Z-TSC, TSD	081	404A	6				17000	19400

Capacities are at 60 Hertz with 65° return gas and 5°F subcooling.

Copeland Scroll® air-cooled condensing units

Capacity Data

HIGH/MED TEMP		Capacity (BTU/Hr) at 90° Ambient - Evaporator Temp (°F)						
Model	BOM	Refrig.	H.P.	+20	+25	+30	+40	+45
FTAH-A13Z-CFV,TFC,TFD	072, 074	134a	1	10100	11200	12400	14900	16300
FJAM-A15Z-CFV	172, 174	404A	1-1/2	11600	12700			
FFAS-A20Z-CFV, TFC	081	22	2	15800	17400	19000	22700	24700
		134a	2	10900	12200	13600	16500	18100
		404A	2	16200	17500			
		407C	2	14400	15900	17600	21200	23100
FFAS-A25Z-CFV, TFC	081	22	2-1/2	18600	20500	22500	26900	29300
		134a	2-1/2	12800	14300	16000	19500	21400
		404A	2-1/2	21200	23200			
		407C	2-1/2	16700	18700	20800	25400	27900
FFAS-A30Z-CFV, TFC	081	22	3	23500	25800	28300	33700	36500
		134a	3	15900	17700	19700	24100	26400
		404A	3	24700	26900			
		407C	3	21400	23600	26100	31300	34200
FFAS-A35Z-CFV, TFC	081	22	3-1/2	26700	29300	32100	37900	41100
		134a	3-1/2	18100	20200	22400	27300	29900
		404A	3-1/2	28000	30400			
		407C	3-1/2	24700	27300	30200	36300	39400
FFAS-A40Z-CFV, TFC	081	22	4	33100	36500	40100	48000	52200
		134a	4	22000	24700	27600	33800	37100
		404A	4	34900	38100			
		407C	4	29800	33200	36800	44700	49000
FFAS-A50Z-CFV, TFC, TFD	081	22	5	39900	44000	48300	57600	62500
		134a	5	26700	29900	33300	40700	44700
		404A	5	42300	46100			
		407C	5	37700	41800	46100	55400	60400
FFAS-A60Z-TFC, TFD	081	22	6	46700	51400	56300	67000	72700
		134a	6	31400	35000	38800	47100	51500
		404A	6	48800	53100			
		407C	6	42700	47200	52000	62400	68100
FPAN-070Z-TFC,TFD	071, 073	134a	7	36300	40300	44500	53600	58600
		404A	7	57100	62400			
FPAN-080Z-TFC,TFD	071,073	134a	8	40200	44600	49300	59400	64900
		404A	8	63000	68600			
FPAN-091Z-TFC, TFD	071, 073	134a	9	44800	49800	55000	66200	72100
		404A	9	70300	76300			
FPAN-101Z-TFC,TFD	071, 073	134a	10	51600	57200	63100	75900	82600
		404A	10	80300	86800			
LOW TEMP		Capacity (BTU/Hr) at 90° Ambient - Evaporator Temp (°F)						
Model	BOM	Refrig.	H.P.	-30	-25	-20	-10	0
DJAL-015Z-CFV, TFC	081	404A	1-1/2	6220	7020	7080	9730	11800
DJAL-020Z-CFV, TFC	081	404A	2	7770	8740	9780	12100	14600
DJAL-022Z-CFV, TFC	081	404A	2+	8540	9560	10600	13000	15600
DJAL-026Z-CFV, TFC	081	404A	2-1/2	10800	12200	13600	16800	20400
DJAL-030Z-CFV, TFC	081	404A	3	12100	13600	15300	18900	22900
DJAL-041Z-CFV,TFC,TFD	081	404A	4	15400	17300	19400	24000	29200
DJAL-051Z-TFC, TFD	081	404A	5	18500	20700	23100	28400	34400
DJAL-060Z-TSC, TSD	081	404A	6	22000	24700	27600	33900	40900

Capacities are at 60 Hertz with 65° return gas and 5°F subcooling.

Copeland Scroll® air-cooled condensing units

Capacity Data

HIGH/MED TEMP		Cap. (BTU/Hr) at 100° F Ambient - Evaporator Temp (°F)						
Model	BOM	Refrig.	H.P.	-5	0	+5	+10	+15
FTAH-A13Z-CFV,TFC,TFD	072, 074	134a	1				7500	8420
FJAM-A15Z-CFV	172, 174	404A	1-1/2	6070	6830	7750	8630	9540
FFAS-A20Z-CFV, TFC	081	22	2					14300
		134a	2			7080	8040	9090
		404A	2	9270	10200	11300	12400	13600
		407C	2					
FFAS-A25Z-CFV, TFC	081	22	2-1/2					
		134a	2-1/2			8330	9460	10700
		404A	2-1/2	12000	13300	14700	16200	17800
		407C	2-1/2					13900
FFAS-A30Z-CFV, TFC	081	22	3					
		134a	3			10300	11700	13300
		404A	3	14100	15500	17200	18900	20700
		407C	3					
FFAS-A35Z-CFV, TFC	081	22	3-1/2					
		134a	3-1/2			11800	13400	15100
		404A	3-1/2	16000	17700	19600	21500	23500
		407C	3-1/2					
FFAS-A40Z-CFV, TFC	081	22	4					28200
		134a	4			14300	16300	18400
		404A	4	19600	21700	24100	26600	29300
		407C	4					25100
FFAS-A50Z-CFV, TFC, TFD	081	22	5					
		134a	5			17400	19700	22400
		404A	5	23900	26500	29400	32300	35500
		407C	5					
FFAS-A60Z-TFC, TFD	081	22	6					
		134a	6			20500	23200	26100
		404A	6	27900	30800	34100	37400	41000
		407C	6					
FPAN-070Z-TFC,TFD	071, 073	134a	7			24100	27200	30500
		404A	7		34200	38500	42800	47200
FPAN-080Z-TFC,TFD	071,073	134a	8			26800	30200	33800
		404A	8		37500	42100	46800	51600
FPAN-091Z-TFC, TFD	071, 073	134a	9			30000	33600	37700
		404A	9		44700	49500	54200	59200
FPAN-101Z-TFC,TFD	071, 073	134a	10			34600	38800	43400
		404A	10		51700	56800	61900	67300
LOW TEMP		Capacity (BTU/Hr) at 100° Ambient - Evaporator Temp (°F)						
Model	BOM	Refrig.	H.P.				-40	-35
DJAL-015Z-CFV, TFC	081	404A	1-1/2				4310	5020
DJAL-020Z-CFV, TFC	081	404A	2				5490	6310
DJAL-022Z-CFV, TFC	081	404A	2+				6210	7050
DJAL-026Z-CFV, TFC	081	404A	2-1/2				7710	8840
DJAL-030Z-CFV, TFC	081	404A	3				8530	9770
DJAL-041Z-CFV,TFC,TFD	081	404A	4				11200	12700
DJAL-051Z-TFC, TFD	081	404A	5				13500	15400
DJAL-060Z-TSC, TSD	081	404A	6				15900	18100

Capacities are at 60 Hertz with 65° return gas and 5°F subcooling.

Copeland Scroll® air-cooled condensing units

Capacity Data

HIGH/MED TEMP		Capacity (BTU/Hr) at 100° Ambient - Evaporator Temp (°F)						
Model	BOM	Refrig.	H.P.	+20	+25	+30	+40	+45
FTAH-A13Z-CFV,TFC,TFD	072, 074	134a	1	9400	10400	11500	13900	15200
FJAM-A15Z-CFV	172, 174	404A	1-1/2	10500	11500			
FFAS-A20Z-CFV, TFC	081	22	2	15800	17400	19000	22700	24700
		134a	2	10200	11500	12800	15600	17100
		404A	2	14800	16000			
		407C	2	13400	14900	16400	19900	21700
FFAS-A25Z-CFV, TFC	081	22	2-1/2	17500	19300	21200	25300	27600
		134a	2-1/2	12100	13500	15100	18500	20300
		404A	2-1/2	19500	21300			
		407C	2-1/2	15500	17400	19300	23700	26000
FFAS-A30Z-CFV, TFC	081	22	3		24300	26700	31700	34400
		134a	3	14900	16700	18600	22700	24900
		404A	3	22600	24600			
		407C	3	19900	22000	24200	29100	31800
FFAS-A35Z-CFV, TFC	081	22	3-1/2		27500	30100	35600	38600
		134a	3-1/2	17000	19000	21100	25700	28200
		404A	3-1/2	25600	27800			
		407C	3-1/2		25100	27800	33600	36500
FFAS-A40Z-CFV, TFC	081	22	4	31200	34500	38000	45400	49500
		134a	4	20800	23400	26100	32000	35200
		404A	4	32100	35100			
		407C	4	28000	31200	34600	42100	46200
FFAS-A50Z-CFV, TFC, TFD	081	22	5	37700	41500	45600	54400	59100
		134a	5	25200	28300	31500	38600	42300
		404A	5	38800	42300			
		407C	5					
FFAS-A60Z-TFC, TFD	081	22	6		48300	53000	63100	68500
		134a	6	29300	32700	36300	44200	48300
		404A	6	44800	48700			
		407C	6	40000	44300	48900	58800	64200
FPAN-070Z-TFC,TFD	071, 073	134a	7	34000	37800	41800	50400	55100
		404A	7	51900	56800			
FPAN-080Z-TFC,TFD	071,073	134a	8	37700	41800	46200	55800	60900
		404A	8	56500	61600			
FPAN-091Z-TFC, TFD	071, 073	134a	9	42000	46600	51500	62100	67700
		404A	9	64400	69800			
FPAN-101Z-TFC,TFD	071, 073	134a	10	48400	53700	59200	71200	77600
		404A	10	72800	78600			
LOW TEMP		Capacity (BTU/Hr) at 100° Ambient - Evaporator Temp (°F)						
Model	BOM	Refrig.	H.P.	-30	-25	-20	-10	0
DJAL-015Z-CFV, TFC	081	404A	1-1/2	5760	6540	7340	9070	10900
DJAL-020Z-CFV, TFC	081	404A	2	7180	8110	9090	11200	13500
DJAL-022Z-CFV, TFC	081	404A	2+	7940	8870	9860	12000	14400
DJAL-026Z-CFV, TFC	081	404A	2-1/2	10000	11300	12700	15600	18900
DJAL-030Z-CFV, TFC	081	404A	3	11100	12600	14100	17400	21100
DJAL-041Z-CFV,TFC,TFD	081	404A	4	14400	16100	18000	22200	26900
DJAL-051Z-TFC, TFD	081	404A	5	17300	19400	21600	26400	31800
DJAL-060Z-TSC, TSD	081	404A	6	20500	23000	25700	31400	37700

Capacities are at 60 Hertz with 65° return gas and 5°F subcooling.

Copeland Scroll® air-cooled condensing units

Capacity Data

HIGH/MED TEMP		Cap. (BTU/Hr) at 110° F Ambient - Evaporator Temp (°F)						
Model	BOM	Refrig.	H.P.	-5	0	+5	+10	+15
FTAH-A13Z-CFV,TFC,TFD	072, 074	134a	1					7830
FJAM-A15Z-CFV	172, 174	404A	1-1/2	5090	5800	6690	7520	8370
FFAS-A20Z-CFV, TFC	081	22	2					
		134a	2				7480	8480
		404A	2		9200	10200	11200	12200
		407C	2					
FFAS-A25Z-CFV, TFC	081	22	2-1/2					
		134a	2-1/2				8820	10000
		404A	2-1/2	10800	12000	13300	14700	16100
		407C	2-1/2					
FFAS-A30Z-CFV, TFC	081	22	3					
		134a	3				10900	12400
		404A	3		14000	15500	17100	18700
		407C	3					
FFAS-A35Z-CFV, TFC	081	22	3-1/2					
		134a	3-1/2				12400	14100
		404A	3-1/2		15900	17600	19300	21200
		407C	3-1/2					
FFAS-A40Z-CFV, TFC	081	22	4					
		134a	4			13300	15200	17200
		404A	4	17700	19700	21900	24200	26600
		407C	4					
FFAS-A50Z-CFV, TFC, TFD	081	22	5					
		134a	5				18400	20900
		404A	5	21600	24000	26600	29300	32200
		407C	5					
FFAS-A60Z-TFC, TFD	081	22	6					
		134a	6				21400	24200
		404A	6		27800	30800	33900	37100
		407C	6					
FPAN-070Z-TFC,TFD	071, 073	134a	7				25300	28400
		404A	7		30000	34000	38000	42100
FPAN-080Z-TFC,TFD	071,073	134a	8				28100	31500
		404A	8		32500	36800	41000	45300
FPAN-091Z-TFC, TFD	071, 073	134a	9				31300	35000
		404A	9		40300	44700	49100	53600
FPAN-101Z-TFC,TFD	071, 073	134a	10				36100	40400
		404A	10			59000	55400	60100
LOW TEMP		Capacity (BTU/Hr) at 110° Ambient - Evaporator Temp (°F)						
Model	BOM	Refrig.	H.P.				-40	-35
DJAL-015Z-CFV, TFC	081	404A	1-1/2				3940	4650
DJAL-020Z-CFV, TFC	081	404A	2				4960	5760
DJAL-022Z-CFV, TFC	081	404A	2+				5710	6490
DJAL-026Z-CFV, TFC	081	404A	2-1/2				7010	8100
DJAL-030Z-CFV, TFC	081	404A	3				7910	9030
DJAL-041Z-CFV,TFC,TFD	081	404A	4				10400	11700
DJAL-051Z-TFC, TFD	081	404A	5				12600	14300
DJAL-060Z-TSC, TSD	081	404A	6				14600	16700

Capacities are at 60 Hertz with 65° return gas and 5°F subcooling.

Copeland Scroll® air-cooled condensing units

Capacity Data

HIGH/MED TEMP		Capacity (BTU/Hr) at 110° Ambient - Evaporator Temp (°F)						
Model	BOM	Refrig.	H.P.	+20	+25	+30	+40	+45
FTAH-A13Z-CFV,TFC,TFD	072, 074	134a	1	8710	9660	10700	12900	14100
FJAM-A15Z-CFV	172, 174	404A	1-1/2	9250	10200			
FFAS-A20Z-CFV, TFC	081	22	2		16400	17900	21400	23300
		134a	2	9570	10700	12000	14600	16100
		404A	2	13300	14500			
		407C	2			15200	18400	20200
FFAS-A25Z-CFV, TFC	081	22	2-1/2			19800	23700	25900
		134a	2-1/2	11300	12700	14200	17400	19100
		404A	2-1/2	17700	19300			
		407C	2-1/2		16000	17800	21800	23900
FFAS-A30Z-CFV, TFC	081	22	3				29800	32300
		134a	3	13900	15600	17400	21300	23400
		404A	3	20500	22300			
		407C	3			22300	26800	29300
FFAS-A35Z-CFV, TFC	081	22	3-1/2				33200	36000
		134a	3-1/2	15800	17800	19800	24100	26400
		404A	3-1/2	23100	25100			
		407C	3-1/2				30800	33500
FFAS-A40Z-CFV, TFC	081	22	4		32500	35700	42800	46600
		134a	4	19500	21900	24500	30200	33200
		404A	4	29200	31900			
		407C	4		29100	32300	39400	43200
FFAS-A50Z-CFV, TFC, TFD	081	22	5			42900	51200	55700
		134a	5	23600	26500	29600	36300	39900
		404A	5	35200	38400			
		407C	5					
FFAS-A60Z-TFC, TFD	081	22	6			49400	59000	64100
		134a	6	27100	30400	33800	41200	45100
		404A	6	40500	44100			
		407C	6			45500	54900	55900
FPAN-070Z-TFC,TFD	071, 073	134a	7	31700	35300	39000	47100	51500
		404A	7	46400	50900			
FPAN-080Z-TFC,TFD	071,073	134a	8	35100	39000	43100	52100	56900
		404A	8	49700	54200			
FPAN-091Z-TFC, TFD	071, 073	134a	9	39100	43400	48000	57900	63200
		404A	9	58300	63200			
FPAN-101Z-TFC,TFD	071, 073	134a	10	45000	50000	55200	66400	72400
		404A	10	65000	70100			
LOW TEMP		Capacity (BTU/Hr) at 110° Ambient - Evaporator Temp (°F)						
Model	BOM	Refrig.	H.P.	-30	-25	-20	-10	0
DJAL-015Z-CFV, TFC	081	404A	1-1/2	5370	6110	6860	8450	10100
DJAL-020Z-CFV, TFC	081	404A	2	6590	7460	8370	10300	12300
DJAL-022Z-CFV, TFC	081	404A	2+	7300	8150	9040	11000	13100
DJAL-026Z-CFV, TFC	081	404A	2-1/2	9240	10400	11700	14400	17200
DJAL-030Z-CFV, TFC	081	404A	3	10200	11500	12900	15900	19200
DJAL-041Z-CFV,TFC,TFD	081	404A	4	13200	14800	16500	20300	22400
DJAL-051Z-TFC, TFD	081	404A	5	16100	18000	20000	24300	29100
DJAL-060Z-TSC, TSD	081	404A	6	18900	21200	23600	28700	34300

Capacities are at 60 Hertz with 65° return gas and 5°F subcooling.

Copeland Scroll® air-cooled condensing units

Physical Data

Model	Refrig.	Comp	Overall Dimensions (In)			Connecting Lines		Minimum Circuit Ampacity - Max Fuse Size			Pump Down Capacity (lbs)	Ship Weight (lbs)
			L	W	H	Suction	Liquid	208/230-1	230-3	460-3		
FTAH-A13Z-CFV,TFC,TFD	134a	ZB15KCE	24.0	18.3	16.2	7/8 S	3/8 S	21.0 - 35	12.5 - 20	7.9 - 15	6.3	131
FJAM-A15Z-CFV	404A	ZB11KCE	24.0	18.6	16.2	7/8 S	3/8 S	13.9 - 20			5.4	130
FFAS-A20Z-CFV, TFC	22	ZB15KCE	25.2	34	19	7/8 S	3/8 S	21.8 - 35	13.3 - 20		15.2	214
	134a		25.2	34.0	19.0	7/8 S	3/8 S	21.8 - 35	13.3 - 20		15.2	214
	404A		25.2	34.0	19.0	7/8 S	3/8 S	21.8 - 35	13.3 - 20		15.2	214
	407C		25.2	34.0	19.0	7/8 S	3/8 S	21.8 - 35	13.3 - 20		15.2	214
FFAS-A25Z-CFV, TFC	22	ZB19KCE	25.2	34.1	19.0	1/8 S	3/8 S	25.2 - 40	15.3 - 20		17.2	222
	134a		25.2	34.1	19.0	1/8 S	3/8 S	25.2 - 40	15.3 - 20		17.2	222
	404A		25.2	34.1	19.0	1/8 S	3/8 S	25.2 - 40	15.3 - 20		17.2	222
	407C		25.2	34.1	19.0	1/8 S	3/8 S	25.2 - 40	15.3 - 20		17.2	222
FFAS-A30Z-CFV, TFC	22	ZB21KCE	25	34.0	19.0	1/8 S	3/8 S	28.7 - 45	17.9 - 25		17.2	224
	134a		25	34.0	19.0	1/8 S	3/8 S	28.7 - 45	17.9 - 25		17.2	224
	404A		25	34.0	19.0	1/8 S	3/8 S	28.7 - 45	17.9 - 25		10.36	224
	407C		25	34.0	19.0	1/8 S	3/8 S	28.7 - 45	17.9 - 25		10.36	224
FFAS-A35Z-CFV, TFC	22	ZB26KCE	25.2	34.0	19.0	1/8 S	3/8 S	32.3 - 50	20.2 - 30		17.2	224
	134a		25.2	34.0	19.0	1/8 S	3/8 S	32.3 - 50	20.2 - 30		17.2	224
	404A		25.2	34.0	19.0	1/8 S	3/8 S	32.3 - 50	20.2 - 30		17.2	224
	407C		25.2	34.0	19.0	1/8 S	3/8 S	32.3 - 50	20.2 - 30		17.2	224
FFAS-A40Z-CFV, TFC	22	ZB30KCE	28.1	44.1	26.8	1-1/8 S	1/2 S	37.1 - 60	23.2 - 35		11.4	336
	134a		28.1	44.1	26.8	1-1/8 S	1/2 S	37.1 - 60	23.2 - 35		11.4	336
	404A		28.1	44.1	26.8	1-1/8 S	1/2 S	37.1 - 60	23.2 - 35		11.4	336
	407C		28.1	44.1	26.8	1-1/8 S	1/2 S	37.1 - 60	23.2 - 35		11.4	336
FFAS-A50Z-CFV, TFC, TFD	22	ZB38KCE	28.1	44.1	26.8	1-1/8 S	1/2 S	42.5 - 60	31.2 - 45	14.4 - 20	11.4	336
	134a		28.1	44.1	26.8	1-1/8 S	1/2 S	42.5 - 60	31.2 - 45	14.4 - 20	11.4	336
	404A		28.1	44.1	26.8	1-1/8 S	1/2 S	42.5 - 60	31.2 - 45	14.4 - 20	11.4	336
	407C		28.1	44.1	26.8	1-1/8 S	1/2 S	42.5 - 60	31.2 - 45	14.4 - 20	11.4	336
FFAS-A60Z-TFC, TFD	22	ZB45KCE	44.1	28.2	26.8	1-1/8 S	1/2 S	31.7 - 50		16.8 - 25	29.5	336
	134a		44.1	28.2	26.8	1-1/8 S	1/2 S	31.7 - 50		16.8 - 25	29.5	336
	404A		44.1	28.2	26.8	1-1/8 S	1/2 S	31.7 - 50		16.8 - 25	29.5	336
	407C		44.1	28.2	26.8	1-1/8 S	1/2 S	31.7 - 50		16.8 - 25	29.5	336
FPAN-070Z-TFC,TFD	134a	ZB50KCE	28.5	37.4	36.8	1-3/8 S	5/8 S		44.8 - 60	23.2 - 30	70.6	495
	404A		28.5	37.4	36.8	1-3/8 S	5/8 S		44.8 - 60	23.2 - 30	60.4	495
FPAN-080Z-TFC,TFD	134a	ZB58KCE	28.5	44.0	36.8	1-3/8 S	5/8 S		49.1 - 70	24.9 - 35	70.6	497
	404A		28.5	44.0	36.8	1-3/8 S	5/8 S		49.1 - 70	24.9 - 35	60.4	497
FPAN-091Z-TFC, TFD	134a	ZB66KCE	28.5	37.4	36.8	1-3/8 S	5/8 S			26.3 - 35	70.6	509
	404A		28.5	37.4	36.8	1-3/8 S	5/8 S		51.0 - 70	26.3 - 35	60.4	509
FPAN-101Z-TFC,TFD	134a	ZB76KCE	28.5	37.4	36.8	1-3/8 S	5/8 S		60.8 - 90	28.4 - 40	79.2	528
	404A		28.5	37.4	36.8	1-3/8 S	5/8 S		60.8 - 90	28.4 - 40	67.8	528
DJAL-015Z-CFV, TFC, TFD	404A	ZF06K4E	25.2	34.3	19.0	1-1/8 S	3/8 S		13.9 - 20	6.8 - 15	15.2	220
DJAL-020Z-CFV, TFC, TFD	404A	ZF08K4E	25.2	34.0	18.8	7/8 S	3/8 S	22.8 - 35	14.4 - 20	7.7 - 15	15.2	220
DJAL-022Z-CFV, TFC, TFD	404A	ZF09K4E	25.2	34.3	19.0	1-1/8 S	3/8 S		16.2 - 20	8.6 - 15	15.2	222
DJAL-026Z-CFV, TFC, TFD	404A	ZF11K4E	25.2	34.0	19.0	1-1/8 S	3/8 S	28.7 - 45	19.8 - 30		17.2	235
DJAL-030Z-CFV, TFC, TFD	404A	ZF13K4E	25.2	34.3	19.0	1-1/8 S	3/8 S		21.6 - 30	13.5 - 15	17.2	254
DJAL-041Z-CFV,TFC,TFD	404A	ZF15K4E	28.2	44.1	26.8	1-1/8 S	1/2 S	43.4 - 70	30.4 - 45	14.4 - 20	29.4	332
DJAL-051Z-TFC, TFD	404A	ZF18K4E	28.2	44.1	26.8	1-1/8 S	1/2 S		33.5 - 50		29.4	342
DJAL-060Z-TSC, TSD	404A	ZF24K4E	28.2	44.1	26.8	1-1/8 S	1/2 S		41.1 - 60	22.0 - 35	29.4	449

BOM	Suction Valve*	Suction Accumulator	Receiver	BX Conduit	Fan Guard	Discharge-Line T'stat	High/ Low Pressure Control	Time Delay Relay (1 Ø)	Filter Drier	Moisture Indicator	Liquid Solenoid Valve w/Coil	Fan Cycle Control
-015	•		•	•	•	•	•	•				•
-020	•		•	•	•	•	•	•				•
-071	•		•	•	•	•	•	•	•	•		•
-072	•		•	•	•	•	•	•	•	•		•
-073	•		•	•	•	•	•	•	•	•	•	•
-074	•		•	•	•	•	•	•	•	•	•	•
-081**	•	•	•	•	•	•	•	•	•	•		•
-172	•		•	•	•	•	•	•	•	•		•
-174	•		•	•	•	•	•	•	•	•	•	•

* except 1-1/2 HP

** includes factory installed Copeland PerformanceAlert™ module

BOM (bills of material) numbers apply only to the units listed in this section. All Models are UL Listed. UL/UR are registered trademarks of Underwriters Laboratories, Inc.

Copevap[®]

Hermetic air-cooled condensing units

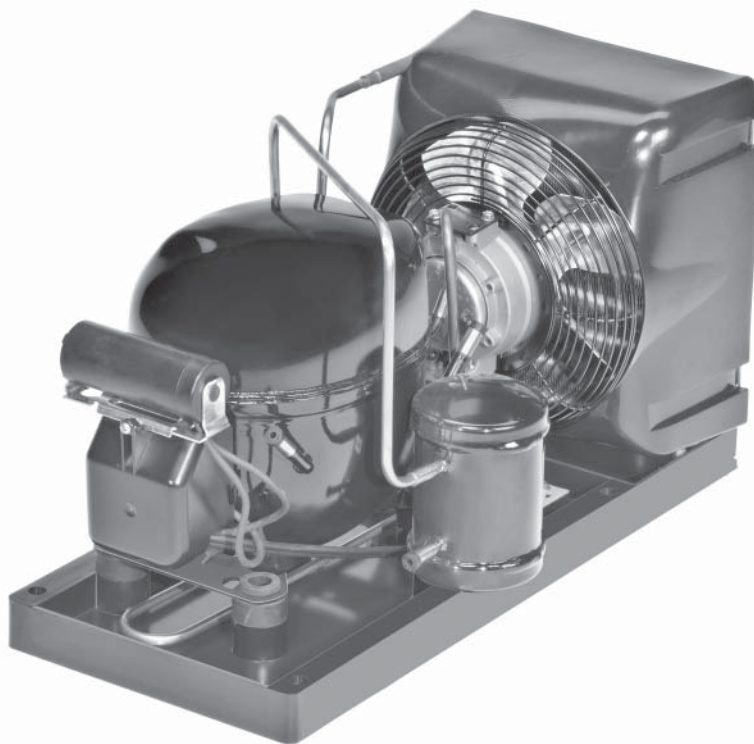

Product Information

Horsepower:	1/6 – 3/4
Temperature Applications:	Low/Medium/High
Refrigerants:	R-134a, R-404A, R-22
Installation Applications:	A variety of applications including under-counter coolers and freezers, sandwich, salad and food prep tables, and milk or juice coolers

Nomenclature • Welded Condensing Units

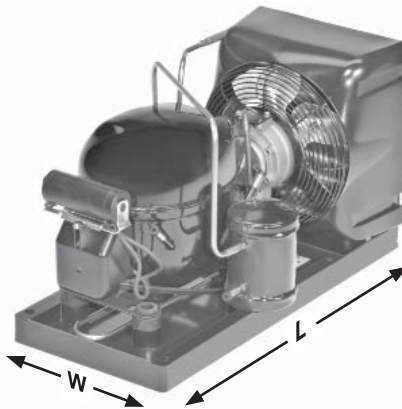
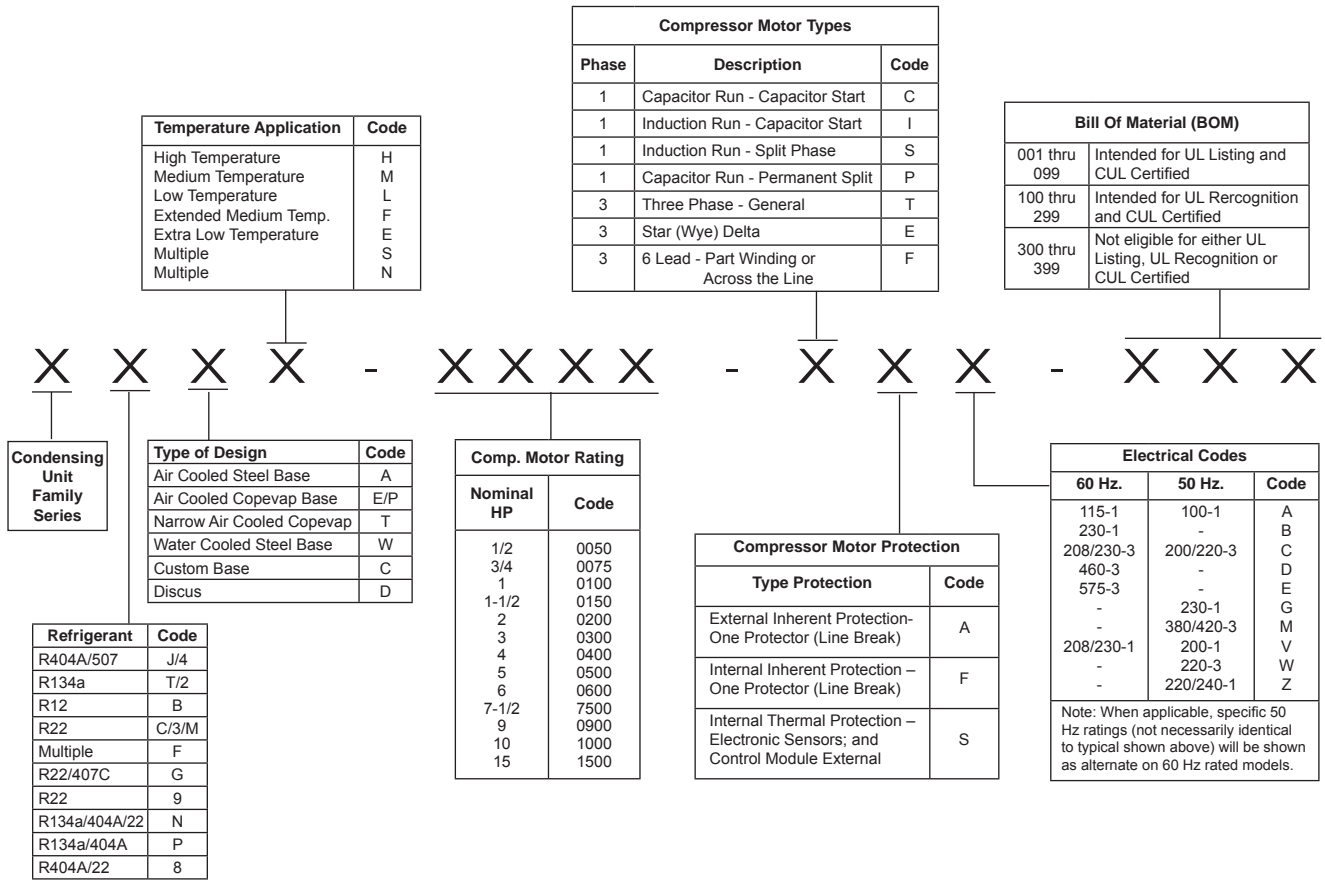

BOM	Suction Valve*	Liquid Connections		BX Conduit	Power Cord	Fan Guard	UR/UL
		Base Valve	Receiver w/Valve				
020	•		•	•		•	UL
111	•	•			•		UR
208	•	•		•		•	UR*
908					•	•	UR
918			•		•	•	UR
212	•		•	•		•	UR*

* These recognized models are identical to the UL listed models less pressure control. Need for the control is to be evaluated by the end use application. UL/UR are registered trademarks of Underwriters Laboratories, Inc.

Copevap® hermetic air-cooled condensing units

Features	Benefits
Copeland® Hermetic Compressor	Reliability
	High Energy Efficiency
	Low Sound & Vibration
Molded Shroud	Optimizes Airflow Across Coil to Help Lower Temperatures
Larger Condensate Holding Base	Quick Evaporation Rate for Condensate Removal
Fan Guard and Power Cord Standard	Cost Savings (No need to add parts)
Compact and Narrow Base Design	Application Flexibility
All Models Rated Up to 100° F Ambient	

Resources and Support

EmersonClimate.com

■ Online Product Information and Technical Data

- Application Engineering Bulletins
- Instruction Sheets
- Marketing Brochures

■ Where to Buy

Application Engineering Bulletins

- 4-1255 U.L. and C.S.A. Agency File Numbers
- 4-1295 HFC-134A Refrigerant Guidelines
- 4-1298 Extended Medium Temperature R-404A/507 Hermetic Compressors and Condensing Units
- 4-1305 System Pro AF, R, AS Refrigeration Hermetic 1/8 - 1 Horsepower Compressors
- 4-1344 Application Guidelines for RFT,RST,RST Compressors
- 5-1340 Care and Cleaning of Air-Cooled Condensing Units
- 8-1376 Electronic Unit Controller
- 17-1260 Compressor Overheating
- 17-1268 Compression Ratio as it Affects Compressor Reliability
- 22-1182 Liquid Refrigerant Control in Refrigeration and Air Conditioning Systems

For more information, visit EmersonClimate.com and login to the Customer Portal to view Online Product Information

Copevap® hermetic air-cooled condensing units

Capacity Data

HIGH/MED TEMP		Capacity (BTU/Hr) at 90° Ambient - Evaporator Temp (°F)						
Model	BOM	Refrig.	H.P.	0	+5	+10	+15	+20
M2TH-0017-IAA	908, 918	134a	1/6	670	760	860	970	1090
M2TH-0020-IAA	908, 918	134a	1/5	790	880	980	1090	1220
M4TM-0020-IAA	908, 918	404A	1/5	980	1090	1190	1290	1400
M2TH-0024-IAA	908, 918	134a	1/4	830	1000	1180	1360	1540
M4TM-H025-IAA	908, 918	404A	1/4	1560	1720	1860	2010	2150
M2EH-0026-IAA	020, 111	134a	1/4		1270	1530	1700	1890
M2PH-0026-IAA	020, 111	134a	1/4		1270	1530	1700	1890
MCEH-0027-IAA	111, 212	22	1/4	1520	1710	1910	2130	2360
MCPH-0027-IAA	111, 208, 212	22	1/4	1520	1710	1910	2130	2360
M4EH-0025-IAA	111, 208, 212	404A	1/4	1600	1730	1890	2060	2240
M4PH-0025-IAA	111, 208, 212	404A	1/4	1600	1730	1890	2060	2230
M2TH-H033-IAA	908, 918	134a	1/3	1390	1540	1710	1900	2100
M4TM-0033-IAA, IAV	908, 918	404A	1/3	1560	1750	1920	2110	2310
M2EH-A033-IAA, IAV	111, 208, 212	134a	1/3		1500	1870	2110	2360
M2PH-A033-IAA, IAV	111, 208, 212	134a	1/3		1500	1870	2110	2360
MCEH-0035-IAA	111, 208, 212	22	1/3	1720	1960	2200	2450	2730
MCPH-0035-IAA	111, 208, 212	22	1/3	1740	1960	2200	2450	2730
M4EH-A035-IAA, IAV	111, 208, 212	404A	1/3	1800	2040	2280	2530	2800
M4PH-A035-IAA, IAV	111, 208, 212	404A	1/3	1800	2040	2280	2530	2800
M2EH-0047-IAA, IAV	111, 208, 212	134a	1/2		2050	2400	2740	3100
M2PH-0047-IAA, IAV	111, 208, 212	134a	1/2		2050	2400	2740	3100
M2EM-A048-IAA	121, 122	134a	1/2	2170	2460	2760	3070	3390
MCEH-0048-CAA, CAV	111, 208, 212	22	1/2	2420	2710	3020	3360	3720
M4EH-0049-CAA, CAV	111, 208, 212	404A	1/2	2470	2750	3020	3310	3620
FTEH-B075-IAA, IAV	208, 212	134a	3/4	2960	3440	3920	4420	4950
F3EH-A078-IAA, IAV	208, 212	22	3/4	3290	3860	4480	5120	5760
M4EF-0075-CAA	212	404A	3/4	3980	4490	4990	5520	6060
LOW TEMP		Capacity (BTU/Hr) at 90° Ambient - Evaporator Temp (°F)						
Model	BOM	Refrig.	H.P.	-25	-20	-15	-10	-5
M4TL-H025-IAA	908, 918	404A	1/4	620	700	780	860	960
M2PL-A025-IAA	111, 208, 212	134a	1/4	720	820	940	1070	1210
M4PL-0025-IAA	020, 111	404A	1/4	610	710	810	920	1040
M4TL-H033-IAA	908, 918	404A	1/3	810	920	1040	1170	1310
M4TL-H034-IAA	908, 918	404A	1/3	1010	1140	1270	1420	1570
M2EL-B033-IAA	020, 111	134a	1/3	850	960	1090	1240	1410
M2PL-B033-IAA	020, 111	134a	1/3	850	960	1090	1240	1410
M4EL-0033-IAA	020, 111, 212	404A	1/3	860	1040	1210	1390	1570
M2EL-0040-IAA	020, 111	134a	1/3	920	1120	1320	1540	1770
M2PL-0040-IAA	020, 111	134a	1/3	920	1120	1320	1540	1770
FTEL-A050-IAA, IAV	208, 212	134a	1/2	1280	1590	1910	2260	2620
M4EL-0039-IAA	111, 208, 212	404A	1/2	1290	1510	1740	1980	2240
M4PL-0039-IAA	111, 208, 212	404A	1/2	1290	1510	1740	1980	2240
M4EL-0050-IAA	111, 208, 212	404A	1/2	1330	1590	1870	2170	2480
M4PL-0050-IAA	111, 208, 212	404A	1/2	1330	1590	1870	2170	2470
M4EF-0080-CFA	212	404A	3/4	2490	2930	3930	3880	4380

Copevap® hermetic air-cooled condensing units

Capacity Data

HIGH/MED TEMP		Capacity (BTU/Hr) at 90° Ambient - Evaporator Temp (°F)						
Model	BOM	Refrig.	H.P.	+25	+30	+35	+40	+45
M2TH-0017-IAA	908, 918	134a	1/6	1210	1340	1480	1630	1770
M2TH-0020-IAA	908, 918	134a	1/5	1350	1500	1650	1810	1970
M4TM-0020-IAA	908, 918	404A	1/5	1520				
M2TH-0024-IAA	908, 918	134a	1/4	1730	1920	2130	2340	2550
M4TM-H025-IAA	908, 918	404A	1/4	2300				
M2EH-0026-IAA	020, 111	134a	1/4	2080	2280	2490	2710	2940
M2PH-0026-IAA	020, 111	134a	1/4	2080	2280	2490	2710	2940
MCEH-0027-IAA	111, 212	22	1/4	2600	2850	3110	3380	3660
MCPH-0027-IAA	111, 208, 212	22	1/4	2600	2850	3110	3380	3660
M4EH-0025-IAA	111, 208, 212	404A	1/4	2430	2620	2820	3030	3240
M4PH-0025-IAA	111, 208, 212	404A	1/4	2430	2620	2820	3030	3270
M2TH-H033-IAA	908, 918	134a	1/3	2320	2560	2800	3040	3290
M4TM-0033-IAA, IAV	908, 918	404A	1/3	2520				
M2EH-A033-IAA, IAV	111, 208, 212	134a	1/3	2620	2900	3190	3500	3820
M2PH-A033-IAA, IAV	111, 208, 212	134a	1/3	2620	2900	3190	3500	3820
MCEH-0035-IAA	111, 208, 212	22	1/3	3020	3330	3650	4000	4360
MCPH-0035-IAA	111, 208, 212	22	1/3	3020	3330	3650	4000	4360
M4EH-A035-IAA, IAV	111, 208, 212	404A	1/3	3100	3430	3810	4230	4710
M4PH-A035-IAA, IAV	111, 208, 212	404A	1/3	3100	3430	3810	4230	4710
M2EH-0047-IAA, IAV	111, 208, 212	134a	1/2	3460	3830	4210	4610	5030
M2PH-0047-IAA, IAV	111, 208, 212	134a	1/2	3460	3830	4210	4610	5030
M2EM-A048-IAA	121, 122	134a	1/2	3740				
MCEH-0048-CAA, CAV	111, 208, 212	22	1/2	4110	4520	4950	5410	5880
M4EH-0049-CAA, CAV	111, 208, 212	404A	1/2	3970	4350	4800	5320	5940
FTEH-B075-IAA, IAV	208, 212	134a	3/4	5510	6130	6810	7550	8350
F3EH-A078-IAA, IAV	208, 212	22	3/4	6450	7130	74870	8660	9440
M4EF-0075-CAA	212	404A	3/4	6620				
LOW TEMP		Capacity (BTU/Hr) at 90° Ambient - Evaporator Temp (°F)						
Model	BOM	Refrig.	H.P.	0	+5	+10	+15	+20
M4TL-H025-IAA	908, 918	404A	1/4	1050				
M2PL-A025-IAA	111, 208, 212	134a	1/4	1370				
M4PL-0025-IAA	020, 111	404A	1/4	1160				
M4TL-H033-IAA	908, 918	404A	1/3	1450	1610	1760	1920	
M4TL-H034-IAA	908, 918	404A	1/3	1720				
M2EL-B033-IAA	020, 111	134a	1/3	1590				
M2PL-B033-IAA	020, 111	134a	1/3	1590				
M4EL-0033-IAA	020, 111, 212	404A	1/3	1750				
M2EL-0040-IAA	020, 111	134a	1/3	2010				
M2PL-0040-IAA	020, 111	134a	1/3	2010				
FTEL-A050-IAA, IAV	208, 212	134a	1/2	2980				
M4EL-0039-IAA	111, 208, 212	404A	1/2	2500				
M4PL-0039-IAA	111, 208, 212	404A	1/2	2500				
M4EL-0050-IAA	111, 208, 212	404A	1/2	2790				
M4PL-0050-IAA	111, 208, 212	404A	1/2	2790				
M4EF-0080-CFA	212	404A	3/4	4880	5440	5980	6530	7080

Copevap® hermetic air-cooled condensing units

Capacity Data

HIGH/MED TEMP		Capacity (BTU/Hr) at 100° Ambient - Evaporator Temp (°F)						
Model	BOM	Refrig.	H.P.	0	+5	+10	+15	+20
M2TH-0017-IAA	908, 918	134a	1/6	610	700	790	890	1000
M2TH-0020-IAA	908, 918	134a	1/5	740	820	900	1010	1120
M4TM-0020-IAA	908, 918	404A	1/5	870	970	1060	1160	1270
M2TH-0024-IAA	908, 918	134a	1/4	760	920	1080	1250	1420
M4TM-H025-IAA	908, 918	404A	1/4	1470	1590	1700	1800	1920
M2EH-0026-IAA	020, 111	134a	1/4		1170	1400	1570	1710
M2PH-0026-IAA	020, 111	134a	1/4		1170	1400	1570	1710
MCEH-0027-IAA	111, 212	22	1/4		1510	1710	1930	2150
MCPH-0027-IAA	111, 208, 212	22	1/4		1510	1710	1930	2150
M4EH-0025-IAA	111, 208, 212	404A	1/4	1460	1560	1700	1870	2030
M4PH-0025-IAA	111, 208, 212	404A	1/4	1460	1560	1700	1870	2030
M2TH-H033-IAA	908, 918	134a	1/3	1290	1430	1580	1750	1940
M4TM-0033-IAA, IAV	908, 918	404A	1/3	1360	1540	1710	1890	2090
M2EH-A033-IAA, IAV	111, 208, 212	134a	1/3		1350	1690	1920	2150
M2PH-A033-IAA, IAV	111, 208, 212	134a	1/3		1350	1690	1920	2150
MCEH-0035-IAA	111, 208, 212	22	1/3		1770	1990	2230	2490
MCPH-0035-IAA	111, 208, 212	22	1/3		1770	1990	2230	2490
M4EH-A035-IAA, IAV	111, 208, 212	404A	1/3	1570	1800	2020	2250	2510
M4PH-A035-IAA, IAV	111, 208, 212	404A	1/3	1570	1800	2020	2250	2510
M2EH-0047-IAA, IAV	111, 208, 212	134a	1/2		1850	2170	2490	2820
M2PH-0047-IAA, IAV	111, 208, 212	134a	1/2		1850	2170	2490	2820
M2EM-A048-IAA	121, 122	134a	1/2		2250	2520	2810	3110
MCEH-0048-CAA, CAV	111, 208, 212	22	1/2		2460	2760	3080	3430
M4EH-0049-CAA, CAV	111, 208, 212	404A	1/2	2190	2480	2760	3050	3370
FTEH-B075-IAA, IAV	208, 212	134a	3/4	2550	3000	3440	3900	4390
F3EH-A078-IAA, IAV	208, 212	22	3/4		3430	4020	4620	5220
M4EF-0075-CAA	212	404A	3/4	3530	3990	4450	4930	5430
LOW TEMP		Capacity (BTU/Hr) at 100° Ambient - Evaporator Temp (°F)						
Model	BOM	Refrig.	H.P.	-25	-20	-15	-10	-5
M4TL-H025-IAA	908, 918	404A	1/4	540	610	690	770	860
M2PL-A025-IAA	111, 208, 212	134a	1/4	670	760	870	1000	1130
M4PL-0025-IAA	020, 111	404A	1/4	560	640	740	840	950
M4TL-H033-IAA	908, 918	404A	1/3	730	830	940	1060	1190
M4TL-H034-IAA	908, 918	404A	1/3		1030	1160	1290	1430
M2EL-B033-IAA	020, 111	134a	1/3	770	880	1000	1150	1300
M2PL-B033-IAA	020, 111	134a	1/3	770	880	1000	1150	1300
M4EL-0033-IAA	020, 111, 212	404A	1/3	690	850	1010	1180	1360
M2EL-0040-IAA	020, 111	134a	1/3	780	960	1150	1350	1570
M2PL-0040-IAA	020, 111	134a	1/3	780	960	1150	1350	1570
FTEL-A050-IAA, IAV	208, 212	134a	1/2	1050	1340	1970	1640	2310
M4EL-0039-IAA	111, 208, 212	404A	1/2	1080	1280	1500	1720	1950
M4PL-0039-IAA	111, 208, 212	404A	1/2	1080	1280	1500	1720	1950
M4EL-0050-IAA	111, 208, 212	404A	1/2	1110	1340	1590	1860	2150
M4PL-0050-IAA	111, 208, 212	404A	1/2	1130	1350	1600	1870	2150
M4EF-0080-CFA	212	404A	3/4	2180	2590	3020	3470	3930

Copevap® hermetic air-cooled condensing units

Capacity Data

HIGH/MED TEMP		Capacity (BTU/Hr) at 100° Ambient - Evaporator Temp (°F)						
Model	BOM	Refrig.	H.P.	+25	+30	+35	+40	+45
M2TH-0017-IAA	908, 918	134a	1/6	1110	1240	1370	1500	1640
M2TH-0020-IAA	908, 918	134a	1/5	1240	1380	1520	1670	1830
M4TM-0020-IAA	908, 918	404A	1/5	1390				
M2TH-0024-IAA	908, 918	134a	1/4	1600	1780	1970	2160	2360
M4TM-H025-IAA	908, 918	404A	1/4	2030				
M2EH-0026-IAA	020, 111	134a	1/4	1890	2080	2300	2520	2710
M2PH-0026-IAA	020, 111	134a	1/4	1890	2080	2300	2520	2710
MCEH-0027-IAA	111, 212	22	1/4	2380	2610	2860	3130	3400
MCPH-0027-IAA	111, 208, 212	22	1/4	2380	2610	2860	3130	3400
M4EH-0025-IAA	111, 208, 212	404A	1/4	2220	2400	2620	2840	3030
M4PH-0025-IAA	111, 208, 212	404A	1/4	2220	2400	2620	2840	3030
M2TH-H033-IAA	908, 918	134a	1/3	2140	2350	2570		
M4TM-0033-IAA, IAV	908, 918	404A	1/3	2320				
M2EH-A033-IAA, IAV	111, 208, 212	134a	1/3	2420	2670	2970	3230	3490
M2PH-A033-IAA, IAV	111, 208, 212	134a	1/3	2420	2670	2970	3230	3490
MCEH-0035-IAA	111, 208, 212	22	1/3	2770	3070	3380	3710	4060
MCPH-0035-IAA	111, 208, 212	22	1/3	2770	3070	3380	3710	4060
M4EH-A035-IAA, IAV	111, 208, 212	404A	1/3	2800	3130	3500	3930	4430
M4PH-A035-IAA, IAV	111, 208, 212	404A	1/3	2800	3130	3500	3930	4430
M2EH-0047-IAA, IAV	111, 208, 212	134a	1/2	3160	3500	3870	4250	
M2PH-0047-IAA, IAV	111, 208, 212	134a	1/2	3160	3500	3870	4250	
M2EM-A048-IAA	121, 122	134a	1/2	3430				
MCEH-0048-CAA, CAV	111, 208, 212	22	1/2	3810	4220	4650	5110	5590
M4EH-0049-CAA, CAV	111, 208, 212	404A	1/2	3730	4140			
FTEH-B075-IAA, IAV	208, 212	134a	3/4	4910	5470	6100	6790	7550
F3EH-A078-IAA, IAV	208, 212	22	3/4	5860	6510	7190	7930	8670
M4EF-0075-CAA	212	404A	3/4	5940				
LOW TEMP		Capacity (BTU/Hr) at 100° Ambient - Evaporator Temp (°F)						
Model	BOM	Refrig.	H.P.	0	+5	+10	+15	+20
M4TL-H025-IAA	908, 918	404A	1/4	940				
M2PL-A025-IAA	111, 208, 212	134a	1/4	1280				
M4PL-0025-IAA	020, 111	404A	1/4					
M4TL-H033-IAA	908, 918	404A	1/3	1320	1460	1600	1740	
M4TL-H034-IAA	908, 918	404A	1/3	1560				
M2EL-B033-IAA	020, 111	134a	1/3	1480				
M2PL-B033-IAA	020, 111	134a	1/3	1480				
M4EL-0033-IAA	020, 111, 212	404A	1/3	1530				
M2EL-0040-IAA	020, 111	134a	1/3	1810				
M2PL-0040-IAA	020, 111	134a	1/3	1810				
FTEL-A050-IAA, IAV	208, 212	134a	1/2	2660				
M4EL-0039-IAA	111, 208, 212	404A	1/2	2180				
M4PL-0039-IAA	111, 208, 212	404A	1/2	2180				
M4EL-0050-IAA	111, 208, 212	404A	1/2	2430				
M4PL-0050-IAA	111, 208, 212	404A	1/2	2430				
M4EF-0080-CFA	212	404A	3/4	4380	4900	5380	5880	6380

Copevap® hermetic air-cooled condensing units

Capacity Data

HIGH/MED TEMP		Capacity (BTU/Hr) at 110° Ambient - Evaporator Temp (°F)						
Model	BOM	Refrig.	H.P.	0	+5	+10	+15	+20
M2TH-0017-IAA	908, 918	134a	1/6	550	630	720	810	910
M2TH-0020-IAA	908, 918	134a	1/5	680	750	820	920	1020
M4TM-0020-IAA	908, 918	404A	1/5		870	970	1070	1190
M2TH-0024-IAA	908, 918	134a	1/4	690	840	990	1150	1300
M4TM-H025-IAA	908, 918	404A	1/4			1540	1610	1680
M2EH-0026-IAA	020, 111	134a	1/4			1330	1470	1570
M2PH-0026-IAA	020, 111	134a	1/4			1330	1470	1570
MCEH-0027-IAA	111, 212	22	1/4			1540	1750	1970
MCPH-0027-IAA	111, 208, 212	22	1/4			1540	1750	1970
M4EH-0025-IAA	111, 208, 212	404A	1/4	1250	1390	1530	1690	1840
M4PH-0025-IAA	111, 208, 212	404A	1/4	1250	1390	1530	1690	1840
M2TH-H033-IAA	908, 918	134a	1/3					
M4TM-0033-IAA, IAV	908, 918	404A	1/3		1360	1540	1730	1940
M2EH-A033-IAA, IAV	111, 208, 212	134a	1/3			1520	1740	1970
M2PH-A033-IAA, IAV	111, 208, 212	134a	1/3			1520	1740	1970
MCEH-0035-IAA	111, 208, 212	22	1/3			1830	2060	2310
MCPH-0035-IAA	111, 208, 212	22	1/3			1830	2060	2310
M4EH-A035-IAA, IAV	111, 208, 212	404A	1/3	1360	1570	1790	2020	2270
M4PH-A035-IAA, IAV	111, 208, 212	404A	1/3	1360	1570	1790	2020	2270
M2EH-0047-IAA, IAV	111, 208, 212	134a	1/2					2570
M2PH-0047-IAA, IAV	111, 208, 212	134a	1/2					2570
M2EM-A048-IAA	121, 122	134a	1/2				2580	2860
MCEH-0048-CAA, CAV	111, 208, 212	22	1/2			2520	2840	3190
M4EH-0049-CAA, CAV	111, 208, 212	404A	1/2			2580	290	
FTEH-B075-IAA, IAV	208, 212	134a	3/4			3050	3470	3910
F3EH-A078-IAA, IAV	208, 212	22	3/4			3540	4100	4660
M4EF-0075-CAA	212	404A	3/4			3940	4370	4820
LOW TEMP		Capacity (BTU/Hr) at 110° Ambient - Evaporator Temp (°F)						
Model	BOM	Refrig.	H.P.	-25	-20	-15	-10	-5
M4TL-H025-IAA	908, 918	404A	1/4		510	590	670	750
M2PL-A025-IAA	111, 208, 212	134a	1/4		700	800	920	1050
M4PL-0025-IAA	020, 111	404A	1/4	500	570	660	750	840
M4TL-H033-IAA	908, 918	404A	1/3		750	850	960	1070
M4TL-H034-IAA	908, 918	404A	1/3				1160	1290
M2EL-B033-IAA	020, 111	134a	1/3		800	920	1050	1200
M2PL-B033-IAA	020, 111	134a	1/3		800	920	1050	1200
M4EL-0033-IAA	020, 111, 212	404A	1/3	520	670	830	990	1160
M2EL-0040-IAA	020, 111	134a	1/3	600	780	970	1170	1390
M2PL-0040-IAA	020, 111	134a	1/3	600	780	970	1170	1390
FTEL-A050-IAA, IAV	208, 212	134a	1/2				1700	2020
M4EL-0039-IAA	111, 208, 212	404A	1/2	850	1050	1250	1470	1670
M4PL-0039-IAA	111, 208, 212	404A	1/2	850	1050	1250	1470	1670
M4EL-0050-IAA	111, 208, 212	404A	1/2	870	1080	1320	1570	1850
M4PL-0050-IAA	111, 208, 212	404A	1/2	880	1090	1330	1580	1850
M4EF-0080-CFA	212	404A	3/4		2290	2680	3080	3500

Copevap® hermetic air-cooled condensing units

Capacity Data

HIGH/MED TEMP		Capacity (BTU/Hr) at 110° Ambient - Evaporator Temp (°F)						
Model	BOM	Refrig.	H.P.	+25	+30	+35	+40	+45
M2TH-0017-IAA	908, 918	134a	1/6	1020	1140	1260	1380	1510
M2TH-0020-IAA	908, 918	134a	1/5	1130	1260	1390	1540	1690
M4TM-0020-IAA	908, 918	404A	1/5	1320				
M2TH-0024-IAA	908, 918	134a	1/4	1470	1630	1810	1990	
M4TM-H025-IAA	908, 918	404A	1/4	1770	---	---		
M2EH-0026-IAA	020, 111	134a	1/4	1740	1910	2100		
M2PH-0026-IAA	020, 111	134a	1/4	1740	1910	2100		
MCEH-0027-IAA	111, 212	22	1/4	2180	2410			
MCPH-0027-IAA	111, 208, 212	22	1/4	2180	2410			
M4EH-0025-IAA	111, 208, 212	404A	1/4	2020	2190			
M4PH-0025-IAA	111, 208, 212	404A	1/4	2020	2190			
M2TH-H033-IAA	908, 918	134a	1/3	1960				
M4TM-0033-IAA, IAV	908, 918	404A	1/3					
M2EH-A033-IAA, IAV	111, 208, 212	134a	1/3	2220	2440	2720		
M2PH-A033-IAA, IAV	111, 208, 212	134a	1/3	2220	2440	2720	2720	
MCEH-0035-IAA	111, 208, 212	22	1/3	2580	2870	3180	3510	
MCPH-0035-IAA	111, 208, 212	22	1/3	2580	2870	3180	3510	
M4EH-A035-IAA, IAV	111, 208, 212	404A	1/3	2570	2900	3290	3750	
M4PH-A035-IAA, IAV	111, 208, 212	404A	1/3	2570	2900	3290	3750	
M2EH-0047-IAA, IAV	111, 208, 212	134a	1/2	2890				
M2PH-0047-IAA, IAV	111, 208, 212	134a	1/2	2890				
M2EM-A048-IAA	121, 122	134a	1/2	3160				
MCEH-0048-CAA, CAV	111, 208, 212	22	1/2	3570	3970			
M4EH-0049-CAA, CAV	111, 208, 212	404A	1/2					
FTEH-B075-IAA, IAV	208, 212	134a	3/4	4380	4900	5470	5470	
F3EH-A078-IAA, IAV	208, 212	22	3/4	5270	5870	6520	7200	7890
M4EF-0075-CAA	212	404A	3/4					
LOW TEMP		Capacity (BTU/Hr) at 110° Ambient - Evaporator Temp (°F)						
Model	BOM	Refrig.	H.P.	0	+5	+10	+15	+20
M4TL-H025-IAA	908, 918	404A	1/4	830				
M2PL-A025-IAA	111, 208, 212	134a	1/4	1190				
M4PL-0025-IAA	020, 111	404A	1/4	930				
M4TL-H033-IAA	908, 918	404A	1/3	1190	1310	1440	1560	
M4TL-H034-IAA	908, 918	404A	1/3					
M2EL-B033-IAA	020, 111	134a	1/3	1360				
M2PL-B033-IAA	020, 111	134a	1/3	1360				
M4EL-0033-IAA	020, 111, 212	404A	1/3	1320				
M2EL-0040-IAA	020, 111	134a	1/3	1630				
M2PL-0040-IAA	020, 111	134a	1/3	1630				
FTEL-A050-IAA, IAV	208, 212	134a	1/2	2350				
M4EL-0039-IAA	111, 208, 212	404A	1/2	1900				
M4PL-0039-IAA	111, 208, 212	404A	1/2	1900				
M4EL-0050-IAA	111, 208, 212	404A	1/2	2130				
M4PL-0050-IAA	111, 208, 212	404A	1/2	2140				
M4EF-0080-CFA	212	404A	3/4	3910	4370	4800	5250	5690

Copevap® hermetic air-cooled condensing units

Physical Data

HIGH/MED TEMP Model	Comp	Overall Dimensions (in)			Connecting Lines		Minimum Circuit Ampacity - Max Fuse Size		Pump Down Capacity (lbs)	Ship Weight (lbs)
		L	W	H	Suction	Liquid	115-1-60-1	230-1-60		
M2TH-0017-IAA	ARB13C3E-IAA	19.0	9.4	10.5	5/16 S	1/4 S	4.4 - 15		2.2	32
M2TH-0020-IAA	ARB17C3E-IAA	19.0	8.5	10.5	5/16 S	1/4 S	5.3 - 15		2.2	33
M4TM-0020-IAA	ASB12C3E-IAA	19.0	8.5	10.5	5/16 S	1/4 S	7.5 - 15		1.9	33
M2TH-0024-IAA	ARE25C3E-IAA	19.0	9.4	10.5	5/16 S	1/4 S	6.7 - 15		2.2	34
M4TM-H025-IAA	ASE20C4E-IAA	19.0	8.5	10.5	5/16 S	1/4 S	8.4 - 15		1.9	34
M2EH-0026-IAA	ARE27C3E-IAA	16.0	14.3	10.5	3/8 S	1/4 S	6.9-15		2.3	41
M2PH-0026-IAA	ARE27C3E-IAA	19.9	11.1	10.6	3/8 S	1/4 S	6.9-15		2.3	41
MCEH-0027-IAA	ARE36C3-IAA	16.0	14.3	10.5	3/8 S	1/4 S	9.1 - 15		2.5	42
MCPH-0027-IAA	ARE36C3-IAA	19.9	11.1	10.5	3/8 S	1/4 S	9.1 - 15		2.5	42
M4EH-0025-IAA	ASE19C3E-IAA	16.0	14.3	10.5	3/8 S	1/4 S	10.7 - 15			36
M4PH-0025-IAA	ASE19C3E-IAA	19.9	11.0	10.5	3/8 S	1/4 S	10.7 - 15		2.2	41
M2TH-H033-IAA	ARE34C4E-IAA	19.0	8.5	10.5	5/16 S	1/4 S	6.6 - 15		2.2	35
M4TM-0033-IAA, IAV	ASE24C3E-IA*	19.0	8.5	10.5	5/16 S	1/4 S	8.4 - 15	5.9 - 15	1.9	35
M2EH-A033-IAA, IAV	ARE37C3E-IA*	16.0	14.3	10.5	3/8 S	1/4 S	9.9-15		2.5	46
M2PH-A033-IAA, IAV	ARE37C3E-IA*	19.9	11.1	10.5	3/8 S	1/4 S	9.9-15	4.9-15	2.5	46
MCEH-0035-IAA	ARE43C3-IAA	16.0	15.1	11.8	3/8 S	1/4 S	9.7 - 15		2.9	47
MCPH-0035-IAA	ARE43C3-IAA	19.9	11.1	10.5	3/8 S	1/4 S	9.7 - 15		2.9	47
M4EH-A035-IAA, IAV	ASE24C3E-IA*	16.0	15.1	11.8	3/8 S	1/4 S	8.4 - 15	5.9 - 15	2.7	45
M4PH-A035-IAA, IAV	ASE24C3E-IA*	19.9	11.1	10.5	3/8 S	1/4 S	8.4 - 15	5.9 - 15	2.7	45
M2EH-0047-IAA, IAV	ART51C1E-IA*	16.2	15.1	11.8	3/8 S	1/4 S	12.5 - 20		2.9	50
M2PH-0047-IAA, IAV	ART51C1E-IA*	19.9	11.1	10.5	3/8 S	1/4 S	12.5 - 20	6.9 - 15	2.9	50
M2EM-A048-IAA	RRT62C1E-IAA	16.6	15.5	11.8	3/8 S	1/4 S	12.8 - 20		3.7	55
MCEH-0048-CAA, CAV	ARE59C3-CA*	16.0	15.3	11.8	3/8 S	1/4 S	10.9 - 15		3.3	54
M4EH-0049-CAA, CAV	ASE32C3E-CA*	16.1	15.3	11.8	3/8 S	1/4 S	12.3 - 20	6.7-15	3.4	50
FTEH-B075-IAA, IAV	RR81C2E-IA*	24.0	16.6	13.7	5/8 S	3/8 S	21 - 30	10.7-15	5.0	114
F3EH-A078-IAA, IAV	RS47C2-IA*	24.0	16.4	13.7	5/8 S	3/8 S	19.9 - 30	10.1-15	6.1	102
M4EF-0075-CAA	RST55C1E-CAA	24.0	16.8	13.7	3/8 S	3/8 S	20.8 - 30		3.2	68
LOW TEMP Model	Comp	Overall Dimensions (in)			Connecting Lines		Minimum Circuit Ampacity - Max Fuse Size		Pump Down Capacity (lbs)	Ship Weight (lbs)
		L	W	H	Suction	Liquid	115-1-60-1	230-1-60		
M4TL-H025-IAA	AFE08C4E-IAA	19.0	8.5	10.5	5/16 S	1/4 S	5.8 - 15		1.9	31
M2PL-A025-IAA	AFE10C3E-IAA	19.9	11.1	10.5	3/8 S	1/4 S	6.9 - 15		2.5	42
M4PL-0025-IAA	AFB09C3E-IAA	19.9	11.1	10.5	3/8 S	1/4 S	6.7-15		2.2	40
M4TL-H033-IAA	AFE11C4E-IAA	19.0	8.5	10.5	5/16 S	1/4 S	6.1 - 15		1.9	35
M4TL-H034-IAA	AFE13C4E-IAA	19.0	8.5	10.5	5/16 S	1/4 S	7.9 - 15		1.9	36
M2EL-B033-IAA	AFE12C3E-IAA	16.0	14.4	10.5	3/8 S	1/4 S	6.7 - 15		2.5	47
M2PL-B033-IAA	AFE12C3E-IAA	19.9	11.1	10.5	3/8 S	1/4 S	6.7 - 15		2.5	47
M4EL-0033-IAA	AFE11C3E-IAA	16.0	14.3	10.5	3/8 S	1/4 S	7.7 - 15		2.2	41
M2EL-0040-IAA	AFT12C1E-IAA	16.1	15.3	11.8	3/8 S	1/4 S	7.3 - 15		2.5	47
M2PL-0040-IAA	AFT12C1E-IAA	19.9	11.1	10.5	3/8 S	1/4 S	7.3 - 15		2.5	47
FTEL-A050-IAA, IAV	RF18C2E-IA*	16.0	15.0	12.7	1/2 S	1/4 S	17 - 25		3.6	76
M4EL-0039-IAA	AFE13C3E-IAA	16.0	15.2	11.8	3/8 S	1/4 S	8.9 - 15		2.5	47
M4PL-0039-IAA	AFE13C3E-IAA	19.9	11.0	10.4	3/8 S	1/4 S	8.9 - 15		2.5	47
M4EL-0050-IAA	AFT18C1E-IAA	16.0	15.0	11.8	1/2 S	1/4 S	10.8 - 15		2.9	55
M4PL-0050-IAA	AFT18C1E-IAA	19.9	11.1	10.5	1/2 S	1/4 S	10.8 - 15		2.9	55
M4EF-0080-CFA	RST64C1E-CFA	24.0	17.1	13.8	5/8 S	3/8 S	20.3 - 30		8.2	85

S = Sweat RS = Rotalock Sweat

BOM	Suction Valve*	Liquid Connections		BX Conduit	Power Cord	Fan Guard	UR/UL
		Base Valve	Receiver w/Valve				
020	•		•	•		•	UL
111	•	•			•		UR
208	•	•		•		•	UR*
908					•	•	UR
918			•		•	•	UR
212	•		•	•		•	UR*

* These recognized models are identical to the UL listed models less pressure control. Need for the control is to be evaluated by the end use application. UL/UR are registered trademarks of Underwriters Laboratories, Inc.

M and F Line

SystemPro® hermetic water-cooled condensing units

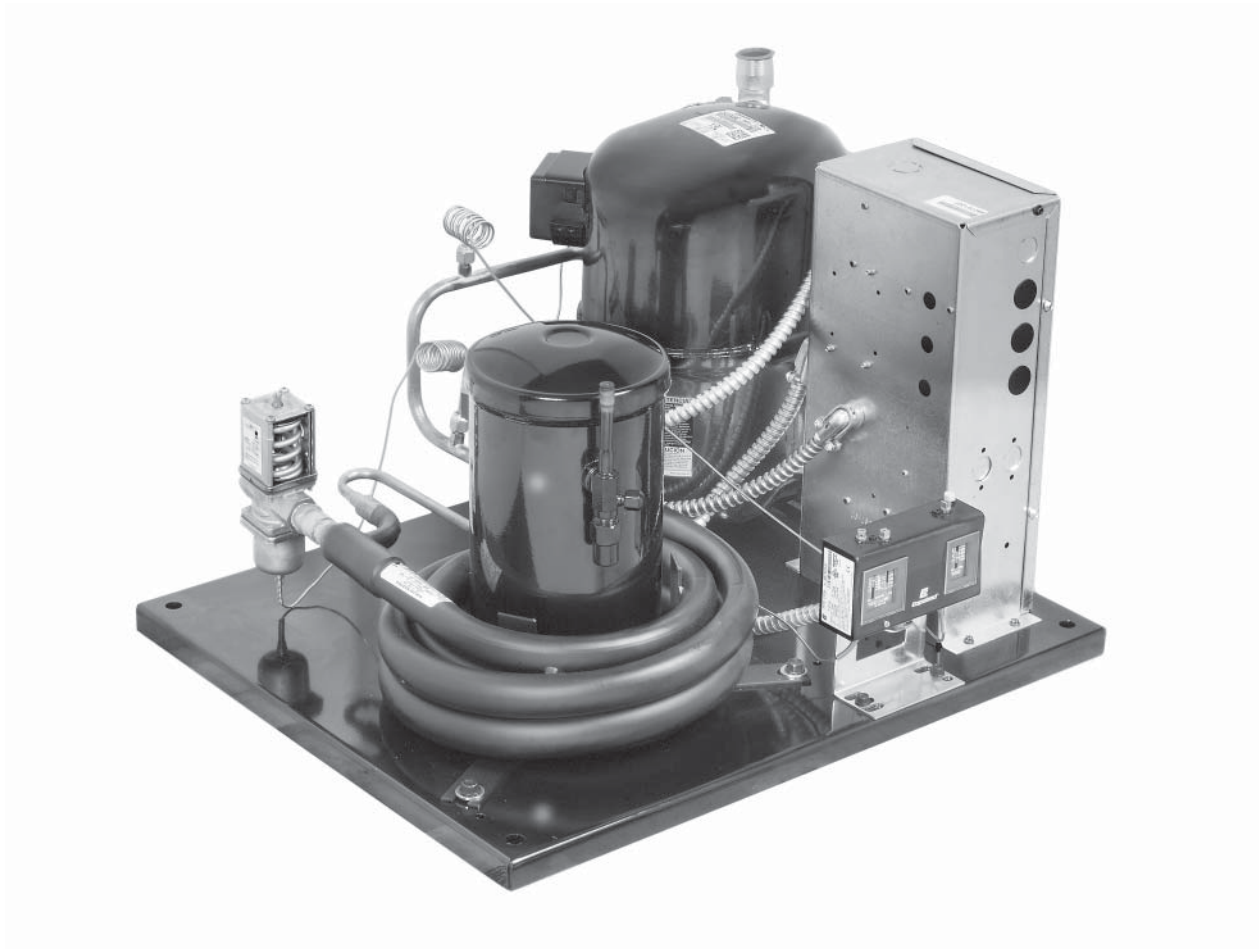

Product Information

Horsepower:	1/4 – 5
Temperature Applications:	Low/Medium/High
Refrigerants:	R-134a, R-404A, R-22, R-407C
Installation Applications:	A variety of applications including walk-in boxes

Nomenclature • Welded Condensing Units

Temperature Application	Code
High Temperature	H
Medium Temperature	M
Low Temperature	L
Extended Medium Temp.	F
Extra Low Temperature	E
Multiple	S
Multiple	N

Compressor Motor Types		
Phase	Description	Code
1	Capacitor Run - Capacitor Start	C
1	Induction Run - Capacitor Start	I
1	Induction Run - Split Phase	S
1	Capacitor Run - Permanent Split	P
3	Three Phase - General	T
3	Star (Wye) Delta	E
3	6 Lead - Part Winding or Across the Line	F

Bill Of Material (BOM)	
001 thru 099	Intended for UL Listing and CUL Certified
100 thru 299	Intended for UL Recognition and CUL Certified
300 thru 399	Not eligible for either UL Listing, UL Recognition or CUL Certified

Type of Design	Code
Air Cooled Steel Base	A
Air Cooled Copevap Base	E/P
Narrow Air Cooled Copevap	T
Water Cooled Steel Base	W
Custom Base	C
Discus	D

Comp. Motor Rating	
Nominal HP	Code
1/2	0050
3/4	0075
1	0100
1-1/2	0150
2	0200
3	0300
4	0400
5	0500
6	0600
7-1/2	7500
9	0900
10	1000
15	1500

Compressor Motor Protection	
Type Protection	Code
External Inherent Protection - One Protector (Line Break)	A
Internal Inherent Protection - One Protector (Line Break)	F
Internal Thermal Protection - Electronic Sensors; and Control Module External	S

Electrical Codes		
60 Hz.	50 Hz.	Code
115-1	100-1	A
230-1	-	B
208/230-3	200/220-3	C
460-3	-	D
575-3	-	E
-	230-1	G
-	380/420-3	M
208/230-1	200-1	V
-	220-3	W
-	220/240-1	Z

Refrigerant	Code
R404A/507	J/4
R134a	T/2
R12	B
R22	C/3/M
Multiple	F
R22/407C	G
R22	9
R134a/404A/22	N
R134a/404A	P
R404A/22	8

Unit Feature -020 Bill of Material

Suction Connections		Liquid Connections		Electrical Connections		UL/UR
Suction Valve	Suction Accum.	Base Valve	Receiver w/Valve	Power Cord	BX Conduit	
•			•		•	UL

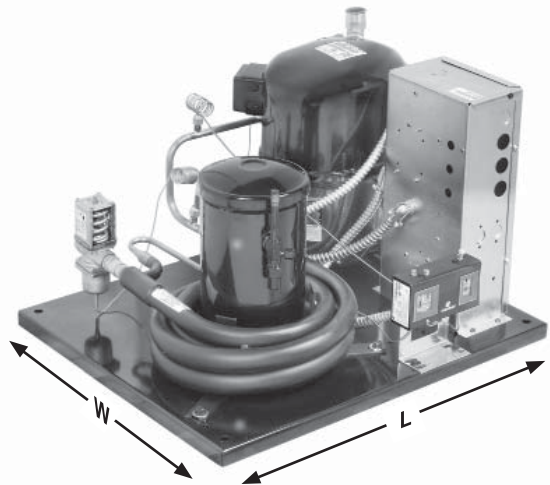

Control Data -020 Bill of Material

Horsepower	Voltage	CC Heater	Dual Pressure Control	Contactor	115 V Control	
					Circuit Transformer	
1/4 -1/2	All	No	Yes	No		No
3/4	115 & 208/230 -1	No	Yes	No		No
1	115 & 208/230 -1	No	Yes	No		No
1	208/230 -3	No	Yes	Yes		No
1-1/4 & 1-1/2	208/230 -1	Yes	Yes	No		No
1-1/4 & 1-1/2	208/230 -3	Yes	Yes	Yes		No
2-5	208/230 -1	Yes	Yes	Yes		No
2-5	208/230 -3	Yes	Yes	Yes		No
2-5	460-3	Yes	Yes	Yes		Yes

* This data applies to units listed in this brochure only.

¹ Except units using R compressor

² Except units using CS or CF compressor

SystemPro® hermetic water-cooled condensing units

Features	Benefits
Copeland® Hermetic Compressor	Reliability
	High Energy Efficiency
Modular Components	Replacement Serviceability
High, Medium, and Low Temperature Ranges	Application Flexibility

Resources and Support

EmersonClimate.com

- Online Product Information and Technical Data
 - Application Engineering Bulletins
 - Instruction Sheets
 - Marketing Brochures
- Where to Buy

Application Engineering Bulletins

- 4-1273 Factors to Consider in Converting Compressor Rated Capacity to Actual Capacity
- 4-1292 Medium Temperature R-22 Copelaweld Compressors
- 4-1295 HFC-135A Refrigerant Guidelines
- 4-1298 Extended Medium Temperature R-404A/507 Hermetic Compressors and Condensing Units
- 4-1305 SystemPro AF, AR, & AS Refrigeration Hermetic 1/8 - 1 Horsepower Compressors
- 4-1306 Application Guidelines for RF Low Temperature Refrigeration Compressors
- 4-1307 Application Guidelines For CF Refrigeration Compressors and Condensing Units
- 5-1174 Water Flow Requirements and Water Pressure Drop for Copeland Water-Cooled Condensing Units
- 11-1147 Suction Accumulators
- 17-1260 Compressor Overheating
- 17-1268 Compression Ratio as it Affects Compressor Reliability
- 22-1182 Liquid Refrigerant Control in Refrigeration and Air Conditioning Systems

For more information, visit EmersonClimate.com and login to the Customer Portal to view Online Product Information

SystemPro® water-cooled condensing units

Capacity Data

HIGH/MED TEMP		Capacity (BTU/Hr) at 75° - Evaporator Temp (°F)					
Model	BOM	Refrig.	H.P.	0	+10	+15	+20
MCWH-C027-IAA	020	22	1/4	1490	1980	2260	2570
M2WH-C026-IAA	020	134a	1/4		1360	1620	1890
M4WH-C025-IAA	020	404A	1/4		2030	2260	2520
MCWH-C036-IAA	020	22	1/3		2280	2600	2950
M2WH-C033-IAA, IAV	020	134a	1/3		1790	2190	2590
M2WH-C040-IAA	020	134a	1/3		2130	2530	2950
M4WH-C036-IAA, IAV	020	404A	1/3		2460	2780	3130
MCWH-C049-CAA, CAV	020	22	1/2		3220	3660	4130
MCWH-C056-IAA, IAV	020	22	1/2		3730	4230	4780
M2WH-C049-IAA, IAV	020	134a	1/2		2590	3050	3540
M2WH-C050-IAA, IAV	020	134a	1/2		2970	3520	4110
M2WH-D056-IAA	020	134a	1/2		3770	4300	4880
M4WH-C050-CAA, CAV	020	404A	1/2		3570	4020	4530
M4WF-C056-IAA, IAV	020	404A	1/2	3250	4200	4730	5290
F3WH-C078-IAA	020	22	3/4		4550	5310	6110
FTWH-C074-IAA, IAV	020	134a	3/4		4260	4940	5690
FTWM-C075-IAA, IAV	020	134a	3/4		4650	5580	6650
M4WF-C075-CAA, CAV	020	404A	3/4	4220	5410	6080	6790
F3WH-C100-CAV	020	22	1		5950	6800	7730
F3WM-C105-CFV, TFC	020	22	1		6550	7720	8970
FPWN-C150-CFV, TFC, TFD	020	134a	1		5150	6260	7510
FJWF-C106-CAV	020	404A	1	5420	6910	7720	8570
FPWN-C225-CFV, TFC, TFD	020	134a	1-1/4		7630	9050	10700
FJWM-C125-CFV, TFC	020	404A	1-1/4	5400	7070	8030	9100
FJWM-C126-CAV, TFC	020	404A	1-1/4	6380	8240	9290	10400
FGWH-A151-CFV, TFC, TFD	020	22	1-1/2		8120	9760	11600
FGWH-A151-CFV, TFC, TFD	020	407C	1-1/2	5370	7950	9330	10800
FPWN-C300-CFV, TFC, TFD	020	134a	1-1/2		9720	11500	13600
FPWN-C150-CFV, TFC, TFD	020	404A	1-1/2	7350	10300	11900	13700
FGWH-A201-CFV, TFC, TFD	020	22	2		10400	12400	14600
FGWH-A201-CFV, TFC, TFD	020	407C	2	6720	9950	11700	13500
FJWM-C200-CFV, TFC	020	404A	2	8720	12000	13900	15800
FGWH-A225-CFV, TFC, TFD	020	22	2-1/4		12000	14200	16600
FGWH-A225-CFV, TFC, TFD	020	407C	2-1/4	8050	11900	14000	16200
FPWN-C225-CFV, TFC, TFD	020	404A	2-1/4	10800	14500	16500	18600
FGWH-A301-CFV, TFC, TFD	020	22	3	12220	17900	20900	24000
FGWH-A301-CFV, TFC, TFD	020	407C	3	9560	15300	18400	21600
FPWN-C300-CFV, TFC, TFD	020	404A	3	13400	18600	21400	24300
FGWH-A325-CFV, TFC, TFD	020	22	3-1/4		20200	23300	26600
FGWH-A325-CFV, TFC, TFD	020	407C	3-1/4	10600	17000	20400	24000
FPWN-C325-CFV, TFC, TFD	020	134a	3-1/4		10300	12600	15000
FPWN-C325-CFV, TFC, TFD	020	404A	3-1/4	15100	20400	23600	27200
FGWH-A401-CFV, TFC, TFD	020	22	4	18700	26300	30400	34700
FGWH-A401-CFV, TFC, TFD	020	407C	4	13900	22400	26800	31500
FJWM-C400-CFV, TFC, TFD	020	404A	4	20100	27500	31700	36400
FGWH-A501-CFV, TFC, TFD, TFE, TFM	020	22	5	21500	30100	34700	39700
FGWH-A501-CFV, TFC, TFD, TFE, TFM	020	407C	5	18100	26800	31800	37400
FJWM-C500-CFV, TFC	020	404A	5	23900	32000	36500	41300

Capacity at 60 Hertz with 5° F subcooling

HT models are rated at 65° F return gas temperature

MT models are rated at 40° F return gas temperature

SystemPro® water-cooled condensing units

Capacity Data

HIGH/MED TEMP		Capacity (BTU/Hr) at 75° - Evaporator Temp (°F)					
Model	BOM	Refrig.	H.P.	+25	+30	+40	+45
MCWH-C027-IAA	020	22	1/4	2910	3300	4200	4730
M2WH-C026-IAA	020	134a	1/4	2160	2450	3100	3470
M4WH-C025-IAA	020	404A	1/4	2790	3090	3790	4190
MCWH-C036-IAA	020	22	1/3	3330	3750	4700	5230
M2WH-C033-IAA, IAV	020	134a	1/3	3000	3420	4350	4860
M2WH-C040-IAA	020	134a	1/3	3390	3870	4920	5520
M4WH-C036-IAA, IAV	020	404A	1/3	3520	3960	5000	5630
MCWH-C049-CAA, CAV	020	22	1/2	4640	5200	6400	7060
MCWH-C056-IAA, IAV	020	22	1/2	5390	6090	7770	8790
M2WH-C049-IAA, IAV	020	134a	1/2	4050	4610	5860	6560
M2WH-C050-IAA, IAV	020	134a	1/2	4720	5390	6860	7680
M2WH-D056-IAA	020	134a	1/2	5510	6190	7730	8580
M4WH-C050-CAA, CAV	020	404A	1/2	5130	5830	7590	8680
M4WF-C056-IAA, IAV	020	404A	1/2	5890			
F3WH-C078-IAA	020	22	3/4	6980	7910	10000	11200
FTWH-C074-IAA, IAV	020	134a	3/4	6530	7490	9820	11200
FTWM-C075-IAA, IAV	020	134a	3/4	7850			
M4WF-C075-CAA, CAV	020	404A	3/4	6790	7560		
F3WH-C100-CAV	020	22	1	8750	9850	12300	13700
F3WM-C105-CFV, TFC	020	22	1	10300			
FPWN-C150-CFV, TFC, TFD	020	134a	1	8900	10500	14000	16200
FJWF-C106-CAV	020	404A	1	9470			
FPWN-C225-CFV, TFC, TFD	020	134a	1-1/4	12500	14400	18700	21000
FJWM-C125-CFV, TFC	020	404A	1-1/4	10300			
FJWM-C126-CAV, TFC	020	404A	1-1/4	11600			
FGWH-A151-CFV, TFC, TFD	020	22	1-1/2	13500	15700	20400	23000
FGWH-A151-CFV, TFC, TFD	020	407C	1-1/2	12400	14000	17700	19800
FPWN-C300-CFV, TFC, TFD	020	134a	1-1/2	15900	18400	23800	26800
FPWN-C150-CFV, TFC, TFD	020	404A	1-1/2	15500			
FGWH-A201-CFV, TFC, TFD	020	22	2	16900	19400	25100	28300
FGWH-A201-CFV, TFC, TFD	020	407C	2	15500	17600	22200	24800
FJWM-C200-CFV, TFC	020	404A	2	17900			
FGWH-A225-CFV, TFC, TFD	020	22	2-1/4	19300	22100	28600	32100
FGWH-A225-CFV, TFC, TFD	020	407C	2-1/4	18600	21100	26600	29700
FPWN-C225-CFV, TFC, TFD	020	404A	2-1/4	20900			
FGWH-A301-CFV, TFC, TFD	020	22	3	27300	30900	39100	43300
FGWH-A301-CFV, TFC, TFD	020	407C	3	25000	28700	37100	41900
FPWN-C300-CFV, TFC, TFD	020	404A	3	27200			
FGWH-A325-CFV, TFC, TFD	020	22	3-1/4	30200	34200	43400	48800
FGWH-A325-CFV, TFC, TFD	020	407C	3-1/4	27800	32000	41400	46700
FPWN-C325-CFV, TFC, TFD	020	134a	3-1/4	17800	20900	28200	32400
FPWN-C325-CFV, TFC, TFD	020	404A	3-1/4	31400			
FGWH-A401-CFV, TFC, TFD	020	22	4	39400	44600	56600	63700
FGWH-A401-CFV, TFC, TFD	020	407C	4	36500	42000	54300	61300
FJWM-C400-CFV, TFC, TFD	020	404A	4	41400			
FGWH-A501-CFV, TFC, TFD, TFE, TFM	020	22	5	45100	50900	63900	71200
FGWH-A501-CFV, TFC, TFD, TFE, TFM	020	407C	5	43400	49900	64300	72300
FJWM-C500-CFV, TFC	020	404A	5	46300			

Capacity at 60 Hertz with 5° F subcooling

HT models are rated at 65° F return gas temperature

MT models are rated at 40° F return gas temperature

SystemPro® water-cooled condensing units

Water Flow Rate Data

HIGH/MED TEMP		Capacity (BTU/Hr) at 75° - Evaporator Temp (°F)								
Model	Refrig.	0	+10	+15	+20	+25	+30	+35	+40	+45
MCWH-C027	22	0.2	0.2	0.2	0.2	0.2	0.3	0.3	0.3	0.3
M2WH-C026	134a	0.1	0.1	0.2	0.2	0.2	0.2	0.2	0.2	0.3
M4WH-C025	404A	0.2	0.2	0.2	0.2	0.2	0.2	0.3	0.3	0.3
MCWH-C036	22	0.2	0.2	0.2	0.3	0.3	0.3	0.3	0.4	0.4
M2WH-C033	134a	0.1	0.2	0.2	0.2	0.2	0.3	0.3	0.3	0.4
M2WH-C040	134a	0.2	0.2	0.2	0.3	0.3	0.3	0.3	0.4	0.4
M4WH-C036	404A	0.2	0.2	0.2	0.3	0.3	0.3	0.3	0.4	0.4
MCWH-C049	22	0.2	0.3	0.3	0.3	0.4	0.4	0.4	0.5	0.5
MCWH-C056	22	0.3	0.3	0.3	0.4	0.4	0.4	0.5	0.5	0.6
M2WH-C049	134a	0.2	0.2	0.3	0.3	0.3	0.4	0.4	0.4	0.4
M2WH-C050	134a	0.2	0.3	0.3	0.3	0.4	0.4	0.5	0.5	0.5
M2WH-D056	134a		0.5	0.6	0.7	0.7	0.8	0.9	1.0	1.1
M4WH-C050	404A	0.2	0.3	0.3	0.4	0.4	0.4	0.5	0.5	0.6
M4WF-C056	404A	0.5	0.3	0.7	0.7	0.8				
F3WH-C078	22	0.3	0.4	0.4	0.5	0.5	0.6	0.6	0.7	0.8
FTWH-C074	134a	0.3	0.4	0.4	0.5	0.5	0.6	0.6	0.7	0.8
FTWM-C075	134a	0.3	0.4	0.5	0.5	0.6				
M4WF-C075	404A	0.6	0.7	0.8	0.9	1.0				
F3WH-C100	22	0.7	0.9	1.0	1.1	1.2	1.4	1.5	1.7	1.8
F3WM-C105	22	0.4	0.5	0.6	0.7	0.7				
FPWN-C150	134a	0.3	0.4	0.5	0.6	0.6	0.7	0.8	0.9	1.0
FJWF-C106	404A	0.8	1.0	1.1	1.2	1.3				
FPWN-C225	134a	0.4	0.6	0.6	0.7	0.8	1.0	1.1	1.2	1.3
FJWM-C125	404A	0.5	0.6	0.6	0.7	0.7				
FJWM-C126	404A	0.6	0.7	0.7	0.8	0.9				
FGWH-A151	22	0.8	1.1	1.3	1.5	1.7	2.0	2.2	2.5	2.8
FGWH-A151	407C	0.8	1.1	1.3	1.4	1.6	1.8	2.0	2.3	2.5
FPWN-C300	134a	0.5	0.7	0.8	0.9	1.1	1.2	1.3	1.5	1.6
FPWN-C150	404A	0.6	0.8	0.9	1.0	1.1				
FGWH-A201	22	1.0	1.4	1.7	1.9	2.2	2.4	2.7	3.1	3.4
FGWH-A201	407C	1.0	1.4	1.6	1.8	2.0	2.3	2.6	2.8	3.1
FJWM-C200	404A	0.7	0.9	1.0	1.1	1.2				
FGWH-A225	22	1.2	1.6	1.9	2.2	2.5	2.8	3.1	3.5	3.9
FGWH-A225	407C	1.1	1.6	1.9	2.2	2.4	2.7	3.1	3.4	3.8
FPWN-C225	404A	0.8	1.1	1.2	1.3	1.4				
FGWH-A301	22	1.7	2.5	2.8	3.2	3.6	4.0	4.5	5.0	5.6
FGWH-A301	407C	1.4	2.1	2.5	2.9	3.3	3.7	4.2	4.7	5.3
FPWN-C300	404A	1.0	1.3	1.5	1.7	1.8				
FGWH-A325	22	1.9	2.6	3.0	3.4	3.8	4.2	4.7	5.2	5.9
FGWH-A325	407C	1.5	2.6	2.8	3.2	3.7	4.1	4.7	5.3	5.9
FPWN-C325	134a	0.5	0.7	0.8	1.0	1.1	1.3	1.5	1.7	1.9
FPWN-C325	404A	1.0	1.3	1.5	1.7	2.0				
FGWH-A401	22	2.5	3.4	3.9	4.4	4.9	5.5	6.1	6.9	7.6
FGWH-A401	407C	2.0	3.1	3.6	4.2	4.8	5.4	6.1	6.9	7.7
FJWM-C400	404A	1.5	2.0	2.2	2.5	2.8				
FGWH-A501	22	2.9	4.0	4.5	5.1	5.7	6.4	7.0	7.8	8.6
FGWH-A501	407C	2.6	3.7	4.3	5.0	5.7	6.5	7.4	8.2	9.2
FJWM-C500	404A	1.8	2.3	2.6	2.8	3.1				

SystemPro® water-cooled condensing units

Physical Data

HIGH/MED TEMP Model	Comp	Overall Dimensions (In)			Connecting Lines		Minimum Circuit Ampacity - Max Fuse Size				Pump Down Capacity (lbs)	Ship Weight (lbs)
		L	W	H	Suction	Liquid	115-1-60-1	230-1-60	230-3-60	460-3-60		
MCWH-C027	ARE36C3	17.9	12.7	8.7	3/8 S	1/4 S	8.3 - 15				1.8	49
M2WH-C026	ARE27C3E	17.9	12.7	8.7	3/8 S	1/4 S	6.2 - 15				1.8	44
M4WH-C025	ASE19C3E	17.9	12.8	9.0	3/8 S	1/4 S	10.0 - 15				2.4	44
MCWH-C036	ARE43C3	17.9	12.8	8.8	3/8 S	1/4 S	8.8 - 15				2.8	46
M2WH-C033	ARE37C3E	17.9	12.7	8.7	3/8 S	1/4 S	9.0 - 15	4.3 - 15			1.8	50
M2WH-C040	ARE41C3E	17.9	12.7	9.2	3/8 S	1/4 S	9.3 - 15				1.8	50
M4WH-C036	ASE24C3E	17.9	12.8	8.7	3/8 S	1/4 S	7.5 - 15	5.3 - 15			2.4	43
MCWH-C049	ARE59C3	17.9	12.8	9.2	3/8 S	1/4 S	10.0 - 15	5.0 - 15			2.8	54
MCWH-C056	ART69C1	17.9	13.3	9.8	3/8 S	1/4 S	16.3 - 25	8.6 - 15			2.8	74
M2WH-C049	ART51C1E	17.9	12.8	9.0	3/8 S	1/4 S	11.6 - 20	6.3 - 15			2.8	60
M2WH-C050	ART62C1E	17.9	12.8	9.8	3/8 S	1/4 S	12.8 - 20	6.7 - 15			2.8	57
M2WH-C056	RRT64C1E	18.5	13.8	9.8	3/8 S	1/4 S	13.8 - 20	7.5 - 15			2.6	60
M4WH-C050	ASE32C3E	17.9	12.8	9.3	3/8 S	1/4 S	11.5 - 20	6.1 - 15			2.4	52
M4WF-C056	RST45C1E	17.4	12.7	10.5	5/8 S	1/4 S	13.1 - 20				2.9	48
F3WH-C078	RS47C2	24.0	17.2	12.1	5/8 S	3/8 S	17.9 - 30	8.9 - 15			4.2	90
FTWH-C074	RR81C2E	18.0	12.7	11.6	5/8 S	1/4 S	19.0 - 30	11.3 - 20			3.5	72
FTWM-C075	RS54C2E	24.0	16.1	11.8	5/8 S	3/8 S	14.8 - 25	8.5 - 15			6.3	94
M4WF-C075	RST55C1E	24.0	16.1	10.7	5/8 S	3/8 S	18.8 - 30	8.5 - 15			6.4	139
F3WH-C100	RS64C2	24.0	17.1	11.7	5/8 S	3/8 S		9.6 - 15			6.2	100
F3WM-C105	RS70C1	24.0	17.3	12.8	7/8 S	3/8 S		8.8 - 15	5.9 - 15		11.9	99
FPWN-C150	CS10K6E	24.0	16.1	16.3	7/8 S	3/8 S		13.6 - 20	9.4 - 15	4.5 - 15	11.2	132
FJWF-C106	RST64C1E	24.2	17.2	10.7	7/8 S	3/8 S		11.3 - 20			5.4	93
FPWN-C225	CS14K6E	24.0	16.9	15.0	7/8 S	3/8 S		15.5 - 25	11.4 - 20	5.9 - 15	10.3	140
FJWM-C125	RS70C1E	24.0	18.5	12.8	7/8 S	3/8 S		8.8 - 15	5.9 - 15		10.3	125
FJWM-C126	RS80C2E	24.0	17.3	12.8	7/8 S	3/8 S		12.0 - 20	8.0 - 15		10.3	119
FGWH-A151	CR18KQE	24.0	16.7	15.0	7/8 S	3/8 S		11.3 - 20	7.5 - 15	3.8 - 15	13.0	120
FPWN-C300	CS18K6E	24.0	16.9	15.0	1-1/8 S	3/8 S		20.0 - 35	13.0 - 20	5.9 - 15	10.3	151
FPWN-C150	CS10K6E	24.0	16.1	16.3	7/8 S	3/8 S		13.6 - 20	9.4 - 15	4.5 - 15	11.2	132
FGWH-A201	CR24KQE	24.0	16.7	15.0	7/8 S	3/8 S		16.9 - 30	9.4 - 15	4.6 - 15	13.0	240
FJWM-C200	CS12K6E	24.0	16.8	15.0	7/8 S	3/8 S		13.6 - 20	9.4 - 15		10.3	130
FGWH-A225	CR28KQE	24.0	16.7	15.0	7/8 S	3/8 S		18.8 - 30	11 - 15	5.5 - 15	13.0	111
FPWN-C225	CS14K6E	24.0	16.8	15.0	7/8 S	3/8 S		15.5 - 25	11.4 - 20	5.9 - 15	10.3	140
FGWH-A301	CR37KQE	25.0	21.0	15.5	1-1/8 S	3/8 S		23.1 - 40	13.9 - 20	7.0 - 15	11.9	175
FPWN-C300	CS18K6E	24.0	16.9	15.0	1-1/8 S	3/8 S		20.0 - 35	13.0 - 20	5.9 - 15	10.3	151
FGWH-A325	CR41KQE	25.0	21.0	15.5	1-1/8 S	3/8 S		24.3 - 40	16.4 - 25	7.4 - 15	11.9	
FPWN-C325	CS20K6E	26.2	21.0	15.5	1-1/8 S	3/8 S		23.3 - 40	14.3 - 25	6.4 - 15	12.0	225
FPWN-C325	CS20K6E	28.0	21.0	15.5	1-1/8 S	3/8 S		23.3 - 40	14.3 - 25	6.4 - 15	10.3	225
FGWH-A401	CR53KQE	26.8	21.0	21.1	1-1/8 S	1/2 S		36.3 - 60	22.5 - 40	11.4 - 20	21.1	325
FJWM-C400	CS27K6E	26.2	21.0	21.0	1-1/8 S	1/2 S		29.9 - 50	19.5 - 35	9.6 - 15	16.5	225
FGWH-A501	CRNQ-050E	25.8	21.8	21.1	1-1/8 S	1/2 S		42.9 - 70	26.8 - 45	12.0 - 20	18.4	342
FJWM-C500	CS33K6E	25.0	21.0	21.1	1-1/8 S	1/2 S		38.4 - 60	23.4 - 40		16.5	189

LOW TEMP Model	Comp	Overall Dimensions (In)			Connecting Lines		Minimum Circuit Ampacity - Max Fuse Size				Pump Down Capacity (lbs)	Ship Weight (lbs)
		L	W	H	Suction	Liquid	115-1-60-1	230-1-60				
M2WL-C025	AFE10C3E	24.0	16.4	9.5	3/8 S	1/4 S	6.9 - 15				1.8	44
M4WL-C025	AFB09C3E	24.0	16.4	9.5	3/8 S	1/4 S	6.7 - 15				1.6	44
M4WL-C033	AFE11C3E	24.0	16.4	9.5	3/8 S	1/4 S	7.7 - 15				1.6	46
FTWL-C050	RF18C2E	24.0	16.1	12.1	1/2 S	1/4 S	16.9 - 25	9.4 - 15			2.6	90
M4WL-C040	AFE13C3E	24.0	16.4	9.5	3/8 S	1/4 S	8.7 - 15				2.2	50
M4WL-H051	AFE17C4E	24.0	16.4	9.5	3/8 S	1/4 S	10.4 - 15				2.4	69
M4WL-C067	AFT26C1E	24.0	16.4	9.9	1/4 S	1/4 S	11.7 - 15				2.4	97
M4WL-C075	RST64C1E	24.0	16.4	10.7	5/8 S	3/8 S	19 - 30	11.8 - 20			6.4	40
FJWL-C103	CF04K6E	24.0	16.4	15.0	7/8 S	3/8 S		12.6 - 20	8.6 - 15		5.4	138
FJWL-C200	CF06K6E	24.0	16.4	15.0	7/8 S	3/8 S		14.8 - 25	9.3 - 15	5.4 - 15	5.4	130
FJWL-C301	CF09K6E	25.0	21.0	21.1	7/8 S	1/2 S		21.4 - 35	13.3 - 20	7.6 - 15	16.3	157
FJWL-C390	CF12K6E	25.0	21.0	21.1	7/8 S	1/2 S		26.2 - 45	15.9 - 25		16.3	150

S = Sweat Note: Water connections (inlet/outlet) 1/2 in.

SystemPro® water-cooled condensing units

Capacity Data

LOW TEMP Model		Capacity (BTU/Hr) at 75° - Evaporator Temp (°F)							
Model	BOM	Refrig.	H.P.	-30	-25	-20	-15	-10	0
M2WL-C025-IAA	020	134a	1/4		700	800	930	1080	1430
M4WL-C025-IAA	020	404A	1/4		580	680	780	900	1180
M4WL-C033-IAA	020	404A	1/3		770	960	1160	1370	1830
FTWL-C050-IAA, IAV	020	134a	1/2		1120	1490	1890	2320	3290
M4WL-C040-IAA	020	404A	1/2		1180	1430	1690	1970	2590
M4WL-H051-IAA	020	404A	1/2		1430	1640	1880	2140	2740
M4WL-C067-CFA	020	404A	1/2		2160	2520	2940	3420	4590
M4WL-C075-CFA, IAV	020	404A	3/4		2600	3050	3550	4100	
FJWL-C103-CFV, TFC	020	404A	1	2170	2940	3730	4590	5550	7930
FJWL-C200-CFV, TFC, TFD	020	404A	2	3940	5020	6250	7620	9090	12300
FJWL-C301-CFV, TFC, TFD	020	404A	3	5810	7360	9110	11000	13200	17800
FJWL-C390-CFV, TFC	020	404A	4	8200	10100	12200	14300	16700	22100

Capacity at 60 Hertz with 5° subcooling

LT models are rated at 40° F return gas temperature

Water Flow Rate Data

LOW TEMP Model		Water Flow Rate (Gal/Min) at 75° Inlet Water - Evaporator Temp (°F)					
Model	Refrig.	-30	-25	-20	-15	-10	0
M2WL-C025	134a		0.1	0.1	0.1	0.1	0.2
M4WL-C025	404A		0.1	0.1	0.1	0.1	0.1
M4WL-C033	404A		0.1	0.1	0.1	0.2	0.2
FTWL-C050	134a		0.2	0.2	0.2	0.2	0.3
M4WL-C040	404A		0.1	0.2	0.2	0.2	0.2
M4WL-H051	404A		0.2	0.3	0.3	0.3	0.4
M4WL-C067	404A		0.2	0.3	0.3	0.3	0.6
M4WL-C075	404A		0.4	0.5	0.6	0.6	0.7
FJWL-C103	404A	0.3	0.4	0.5	0.6	0.6	0.7
FJWL-C200	404A	0.4	0.5	0.6	0.7	0.8	1.0
FJWL-C301	404A	0.6	0.7	0.8	0.9	1.1	1.4
FJWL-C390	404A	1.2	1.4	1.7	2.0	2.3	3.0

Unit Feature -020 Bill of Material

Suction Connections		Liquid Connections		Electrical Connections		UL/UR
Suction Valve	Suction Accumulator	Base Valve	Receiver w/Valve	Power Cord	BX Conduit	
•			•		•	UL

Control Data -020 Bill of Material

Horsepower	Voltage	CC Heater	Dual Pressure Control	Contactor	115 V Control
					Circuit Transformer
1/4 -1/2	All	No	Yes	No	No
3/4	115 & 208/230 -1	No	Yes	No	No
1	115 & 208/230 -1	No	Yes	No	No
1	208/230 -3	No	Yes	Yes	No
1-1/4 & 1-1/2	208/230 -1	Yes	Yes	No	No
1-1/4 & 1-1/2	208/230 -3	Yes	Yes	Yes	No
2-5	208/230 -1	Yes	Yes	Yes	No
2-5	208/230 -3	Yes	Yes	Yes	No
2-5	460-3	Yes	Yes	Yes	Yes

* This data applies to units listed in this brochure only.

¹ Except units using R compressor

² Except units using CS or CF compressor

C, D and E Line

Copelametic® air-cooled condensing units

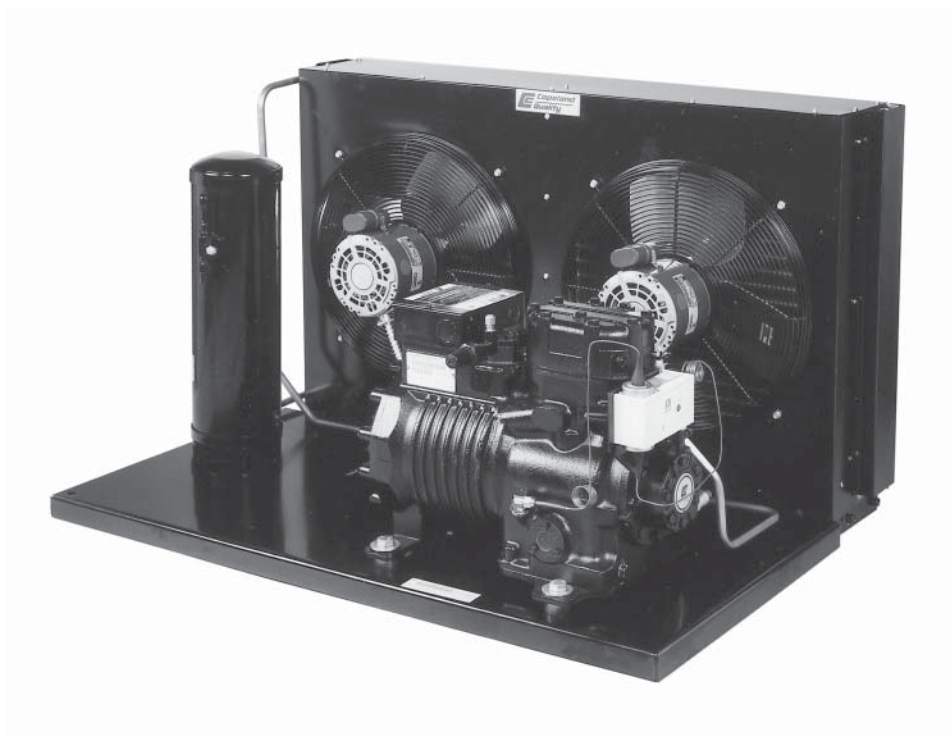

Product Information

Horsepower:	1/2 – 10
Temperature Applications:	Low/Medium/High
Refrigerants:	R-134a, R-404A, R-22, R-407C
Installation Applications:	A variety of applications including walk-ins

Nomenclature • Semi-Hermetic Condensing Units

Receiver Base	C
Flat Metal Base	E, D
Water Condenser Base	W
Transport Unit	T

Temperature Application	
Description	Code
High Temperature	H
Medium Temperature	M
Low Temperature	L
Extended Medium Temp.	F
Extra Low Temp.	E
High Temperature	B
R22/404A LT & R134a HT	G
R22 HT & R404A MT	J
R404A LT & R134a HT	K
Two Stage	U
Two Stage	T

Compressor Motor Types		
Phase	Description	Code
1	Capacitor Run – Capacitor Start	C
1	Induction Run – Capacitor Start	I
1	Induction Run – Split Phase	S
1	Capacitor Run – Permanent Split Capacitor	P
3	Three Phase	T
3	Wye (star) Delta	E
3	6 Lead Part Winding or Across the Line – except 575V	F

Product Variations
Numbers will be assigned as follows:

- Number –100 is standard compressor used in Copeland® condensing units.
- Number –200 indicates a STANDARD compressor parts B/M and model no.
- Number –201 and larger will be assigned for all other variations of a given model.
- Number –800 indicates a standard replacement compressor and Component Parts B/M and model no. –240 volt control.
- Number –801 indicates a standard replacement compressor and component parts B/M and model no. –120 volt control.



Refrigerant	
R404A/507	J/4
R134a	T/2
R12	B/7
R22	3/M/L/C
Multiple	F
R22/407C	G
R22	9
R134a/404A/22	N
R134a/404A	P
R404A/22	8

Air Cooled Steel Base	A
Air Cooled Copevap Base	E
Water Cooled Steel Base	W
Custom Base	C
Discus	D

Comp. Motor Rating	
Nominal (HP)	Code
1/2	0050
3/4	0075
1	0100
1-1/2	0150
2	0200
3	0300
4	0400
5	0500
6	0600
7-1/2	0750
9	0900
10	1000
15	1500
20	2000
22	2200
25	2500
27	2700
30	3000
40	4000
50	5000
60	6000
70	7000
80	8000

Note: Left position may be a letter indicating a revision change

Compressor Motor Protection	
Type Protection	Code
External Inherent Protection-One Protector, (Line Break) Use with Contactor	A
Internal Inherent Protection-One Protector (Line Break) Use with Contactor	F
Internal Thermal Protectors-Electronic Sensors; and Control Module External Use with Contactor	S

Electrical Codes		
60 Hz.	50 Hz.	Code
115-1	100-1	A
230-1	-	B
208/230-3	200/220-3	C
460-3	-	D
575-3	-	E
-	230-1	G
-	380/420-3	M
208/230-1	200-1	V
-	220-3	W
-	220/240-1	Z

Note: When applicable, specific 50 Hz ratings (not necessarily identical to typical shown above) will be shown as alternate on 60 Hz rated models.

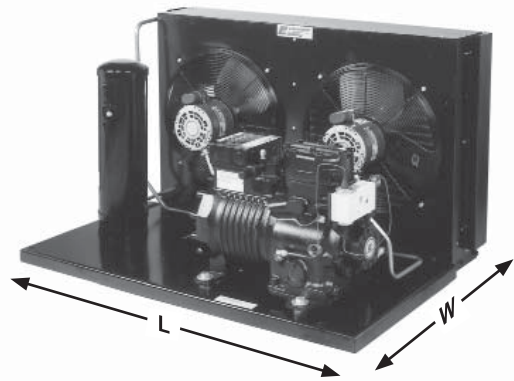

Control Data

Unit	Horsepower	Voltage	BOM	Low Pressure Control	High/Low Pressure Control	Contactor	115 V Control
							Circuit Transformer
E	1/4 - 1/3	All	020	No	No	No	No
E	1/2 - 1	115-1, 208/230-1	020	Yes	No	No	No
E	1 1/2 - 2	115-1, 208/230-1	020		Yes	No	No
E	1/2 - 1	208/230-3	020		Yes	Yes	No
E	1/2 - 1	460-3	020		Yes	Yes	Yes
D	2 - 3	208/230-1	020		Yes	No	No
D	2 - 3	208/230-3	020		Yes	Yes	No
D	2 - 3	460-3	020		Yes	Yes	Yes
C	3/4 - 3	208/230-1	001		Yes	No	No
C	3/4 - 10	208/230-3	001		Yes	Yes	No
C	3 - 10	460-3, 575-3	001		Yes	Yes	Yes

All units come standard with a suction valve and receiver. All units are UL Listed.

Copelametic® air-cooled condensing units

Features	Benefits
Copeland® Semi-hermetic Compressor Copeland Discus® Compressor with Unique 'Discus' Valve Design	Reliability
	High Energy Efficiency
Modular Components	Replacement Serviceability
Positive Displacement Oil Pump	Application Flexibility
Low Profile	More Cooler Space, Fewer Stockouts, Application Flexibility
Low Re-expansion Volumes	Decrease Energy Costs, Greater Capacity
Lower Operating Speeds	Reduces Operating Component Stress Low Sound Lower Maintenance Costs

Resources and Support

EmersonClimate.com

■ Online Product Information and Technical Data

- Application Engineering Bulletins
- Instruction Sheets
- Marketing Brochures

■ Where to Buy

Application Engineering Bulletins

- 1094 Identification of Port Locations in Heads of Copelametic® Compressors
- 1135 Cooling Requirement for Copelametic Compressors
- 1166 Copeland® Oil Pumps
- 1283 Discus® R-22 Envelope Extended
- 1287 Copeland Discus™ Demand Cooling
- 1336 Discus™ Optimized Medium Temperature Models Bulletin
- 1174 Water Flow Requirement and Water Pressure Drop for Copeland® Water Cooled Condensing Units
- 1275 SENTRONIC+™ Electronic Oil Pressure Control
- 1147 Suction Accumulators
- 1297 Liquid Line Filter-Driers
- 1234 Low Ambient Compressor Operation
- 1182 Liquid Refrigerant Control in Refrigeration and Air Conditioning Systems

For more information, visit EmersonClimate.com and login to the Customer Portal to view Online Product Information

Copelametic® air-cooled condensing units

Summary Data

Model	Compressor	H.P.	Fans	Refrigerant				
				R-12	R-22	R-404A	R-507*	R-134a
E8AL-A050-CAV	KANB-005E	1/2	1		LT	LT	LT	
EJAL-A050-CAV, IAA, TAC	KAN*-00*E	1/2	1			LT	LT	
ENAG-A050-IAA	KANB-005E	1/2	1		LT	LT		HT
E3AM-A075-CAA,CAV,TAC	KAE*-0075	3/4	1		MT			
E8AJ-A075-CAV,TAC	KAN*-007E	3/4	1		HT	MT	MT	
E8AL-A075-CAA,TAC	KAM*-007E	3/4	1		LT	LT	LT 1	
ENAG-A075-CAV	KAMB-007E	3/4	1		LT	LT		HT
C7AB-0100-CAV,TAC,TAD	KAJ*-0100	1	1	HT				
CBAM-0103-TAC,TAD	KAK1-0100	1	1	MT				
C8AJ-0100-CAV,TAC,TAD	KAR*-010E	1	1		HT	MT	MT 2	
E8AJ-A100-CAV,TAC,TAD	KAR*-010E	1	1		HT	MT	MT 2	
E3AM-A101-CAV, TAC, TAD	KAM*-0100	1	1		MT			
C3AM-0101-CAV,TAC,TAD	KAM*-0100	1	1		MT			
CNAG-0100-CAV,TAC	KAJB-010E	1	1		LT	LT	LT 2	HT
ENAG-A100-CAV,TAC	KAJB-010E	1	1		LT	LT	LT 2	HT
C7AB-0150-CAV,TAC	KALB-0150	1-1/2	1	HT				
CBAM-0153-CAV,TAC	KATB-0150	1-1/2	1	MT				
E3AH-A151-CAV,TAC	KAGB-0150	1-1/2	1		wi			
C3AH-0150-CAV,TAC,TAD	KAG*-0150	1-1/2	1		HT			
CLAL-0152-CAB	EADB-0200	1-1/2	1		LT			
C8AL-0151-TAC	EADA-020E	1-1/2	1		LT	LT	LT	
EJAL-A150-TAD	KALA-016E	1-1/2	1			LT	LT	
CJAL-0152-TAD	KALA-016E	1-1/2	1			LT	LT	
CJAL-0153-CAB	EADB-021E	1-1/2	1			LT		
EPAK-A150-CAV,TAC	KALA-016E	1-1/2	1			LT	LT	HT
CPAK-0150-CAV,TAC	KALA-016E	1-1/2	1			LT	LT	HT
C7AB-0200-CAB,TAC,TAD	EAV*-0200	2	1	HT				
D8AJ-0200-CAV,TAC	KAKB-021E	2	2		HT	MT	MT	
D8AM-0201-TAC,TAD	ERCA-021E	2	2		MT	MT	MT	
C3AH-0204-TAD	KAKA-0200	2	1		HT			
C3AM-0202-CAB	ERC2-0200	2	1		MT			
C8AJ-0200-CAV,TAC	KAKB-021E	2	1		HT	MT	MT	
C8AM-0202-TAC,TAD	ERCA-021E	2	1		MT	MT	MT	
C8AL-0200-TAD	EAVA-021E	2	1		LT	LT	LT	
DNAG-0200-CAV,TAC	EAVB-021E	2	2		LT	LT	LT	HT
CNAG-0200-CAV,TAC	EAVB-021E	2	1		LT	LT	LT	HT
C7AB-0300-CAB,TAC,TAD	LAH1-0310	3	1	HT				
D8AJ-0300-TAC,TAD	ERFA-031E	3	2		HT	MT	MT	
C8AJ-0300-TAC,TAD	ERFA-031E	3	1		HT	MT	MT	
C3AH-0303-CAB, TAC, TAD, TAE	ERF2-0310	3	1		HT			
CLAL-0300-CAB,TAC,TAD	LAH*-031*	3	1		LT			
DLAL-0301-CAB,TAC,TAD	LAH*-031*	3	2		LT			
DJAL-0300-TAD	LAHA-032E	3	2			LT	LT 3	
CJAL-0300-CAB,TAC,TAD, TAE	LAH*-032E	3	1			LT	LT 3	
DTAH-0300-CAB	LAHB-031E	3	2					HT
CTAH-0300-CAB	LAHB-031E	3	1					HT
CPDK-0300-TFC,TFD,TFE	2DF3F16KE	3	1			LT	LT	HT
CMDL-0400-TFC	2DL3F20K0	4	1		LT			
CJDL-0400-TFC,TFD,TFE	2DL3F20KE	4	1			LT	LT	
C8DJ-0500-TFC,TFD,TFE	2DC3R53KE	5	1		HT	MT	MT	
C8DJ-0501-TFC,TFD	2DD3R63KE	5	1		HT	MT	MT	
CPDK-0600-TFC,TFD	2DA3F23KE	6	1			LT	LT	HT
CPDK-0601-TFC,TFD	3DA3F28KE	6	1			LT	LT	HT
C8DJ-0750-TFC	2DA3R89KE	7-1/2	1		HT	MT	MT	
CPDK-0750-TFC,TFD,TFE	3DB3F33KE	7-1/2	1			LT	LT	HT
CPDK-0900-TFC,TFD	3DF3F40KE	9	2			LT	LT	HT
C8DJ-1000-TFC,TFD	3DB3R12ME	10	2		HT	MT	MT	
CPDK-1000-TFC,TFD	3DS3F46KE	10	2			LT	LT	HT

Copelametic® air-cooled condensing units

Capacity Data

HIGH/MED TEMP		Capacity (BTU/Hr) at 90° Ambient - Evaporator Temp (°F)						
Model	BOM	Refrig.	H.P.	-5	0	+10	+15	+20
ENAG-A050-IAA	020	134a	1/2		1900	2380	2650	2930
E8AJ-A075-CAV,TAC	020	22	3/4		3380	4340	4880	5450
E3AM-A075-CAA,CAV,TAC	020	22	3/4	3580	4060	5090	5670	6290
E8AJ-A075-CAV,TAC	020	404A	3/4	3090	3520	4550	5100	5670
ENAG-A075-CAV	020	134a	3/4	2880	3310	4290	4830	5390
C7AB-0100-CAV,TAC,TAD	001	12	1		4550	5740	6400	7120
CBAM-0103-TAC,TAD	001	12	1		5150	6450	7170	7940
C8AJ-0100-CAV,TAC,TAD	001	22	1		5070	6440	7220	8040
C3AM-0101-CAV,TAC,TAD	001	22	1		5710	7410	8330	9300
E8AJ-A100-CAV,TAC,TAD	020	22	1		4820	6110	6830	7590
E3AM-A101-CAV,TAC,TAD	020	22	1		5780	7510	8450	9440
E8AJ-A100-CAV,TAC,TAD	020	404A	1	4810	5350	6650	7320	7980
C8AJ-0100-CAV,TAC,TAD	001	404A	1	4870	5420	6800	7520	8230
CNAG-0100-CAV,TAC	001	134a	1		4580	5770	6450	7170
ENAG-A100-CAV,TAC	020	134a	1		4360	5470	6090	6750
C7AB-0150-CAV,TAC	001	12	1-1/2		6240	7960	8910	9930
CBAM-0153-CAV,TAC	001	12	1-1/2	6540	7430	9430	10500	10500
E3AH-A151-CAV,TAC	020	22	1-1/2		6310	7910	8880	9960
C3AH-0150-CAV,TAC,TAD	001	22	1-1/2		6130	7990	8990	10100
EPAK-A150-CAV,TAC	020	134a	1-1/2		6290	7980	8940	9970
CPAK-0150-CAV,TAC	001	134a	1-1/2		6400	8180	9170	10230
C7AB-0200-CAB,TAC,TAD	001	12	2		8380	11100	12400	13800
D8AJ-0200-CAV,TAC	020	22	2		8100	11000	12500	14000
D8AM-0201-TAC,TAD	020	22	2	8220	9410	12240	13860	15620
C8AJ-0200-CAV,TAC	001	22	2		7860	10700	12100	13500
C3AH-0204-TAD	001	22	2		7860	10700	12100	13500
C3AM-0202-CAB	001	22	2	7980	9100	11700	13200	14800
C8AM-0202-TAC,TAD	001	22	2	8010	9150	11800	13300	15000
D8AJ-0200-CAV,TAC	020	404A	2	8410	9550	11800	13000	14300
D8AM-0201-TAC,TAD	020	404A	2	9800	11100	14000	15400	17000
C8AJ-0200-CAV,TAC	001	404A	2	8170	9240	11300	12400	13700
C8AM-0202-TAC,TAD	001	404A	2	9350	10570	13160	14490	15900
DNAG-0200-CAV,TAC	020	134a	2		8380	11090	12560	14120
CNAG-0200-CAV,TAC	001	134a	2		8120	10700	12000	13500
C7AB-0300-CAB,TAC,TAD	001	12	3		14700	18400	20500	22700
D8AJ-0300-TAC,TAD	020	22	3		14840	18890	21110	23480
C3AH-0303-CAB,TAC,TAD,TAE	001	22	3		14750	18950	21300	23800
C8AJ-0300-TAC,TAD	001	22	3		14750	18950	21300	23800
D8AJ-0300-TAC,TAD	020	404A	3	14600	16400	20500	22600	25000
C8AJ-0300-TAC,TAD	001	404A	3	14800	16600	20900	23200	25700
DTAH-0300-CAB	020	134a	3		15090	18100	19940	21970
CTAH-0300-CAB	001	134a	3		14500	18400	20500	22700
CPDK-0300-TFC,TFD,TFE	001	134a	3		19010	24420	27360	30470
C8DJ-0500-TFC,TFD,TFE	001	22	5	19400	22600	29600	33500	37500
C8DJ-0501-TFC,TFD,TFE	001	22	5			33300	37700	42200
C8DJ-0500-TFC,TFD,TFE	001	404A	5	22300	25100	31660	35240	39020
C8DJ-0501-TFC,TFD	001	404A	5	26700	29800	37300	41300	45500
CPDK-0600-TFC,TFD	001	134a	6		25150	32560	36700	41130
CPDK-0601-TFC,TFD	001	134a	6		29830	38550	43320	48390
C8DJ-0750-TFC	001	22	7-1/2			50800	56300	62300
C8DJ-0750-TFC	001	404A	7-1/2	40100	44600	54500	59900	65500
CPDK-0750-TFC,TFD,TFE	001	134a	7-1/2		34200	44200	49600	55300
CPDK-0900-TFC,TFD	001	134a	9		42600	55500	62500	69900
C8DJ-1000-TFC,TFD	001	22	10		62100	77300	85700	94600
C8DJ-1000-TFC,TFD	001	404A	10	59400	66600	82200	90600	99500
CPDK-1000-TFC,TFD	001	134a	10		46400	60310	67840	75830

Copelametic® air-cooled condensing units

Capacity Data

HIGH/MED TEMP		Capacity (BTU/Hr) at 90° Ambient - Evaporator Temp (°F)						
Model	BOM	Refrig.	H.P.	+25	+30	+35	+40	+45
ENAG-A050-IAA	020	134a	1/2	3240	3560	3900	4250	4620
E8AJ-A075-CAV,TAC	020	22	3/4	6060	6710	7380	8090	8820
E3AM-A075-CAA,CAV,TAC	020	22	3/4	6980				
E8AJ-A075-CAV,TAC	020	404A	3/4	6240				
ENAG-A075-CAV	020	134a	3/4	5990	6620	7270	7960	
C7AB-0100-CAV,TAC,TAD	001	12	1	7860	8660	9500	10400	11300
CBAM-0103-TAC,TAD	001	12	1	8750				
C8AJ-0100-CAV,TAC,TAD	001	22	1	8910	9830	10800	11800	12800
C3AM-0101-CAV,TAC,TAD	001	22	1	10300				
E8AJ-A100-CAV,TAC,TAD	020	22	1	8400	9240	10100	11000	11900
E3AM-A101-CAV,TAC,TAD	020	22	1	10500				
E8AJ-A100-CAV,TAC,TAD	020	404A	1	8600				
C8AJ-0100-CAV,TAC,TAD	001	404A	1	8900				
CNAG-0100-CAV,TAC	001	134a	1	7950	8770	9630	10540	11500
ENAG-A100-CAV,TAC	020	134a	1	7440	8170	8920	9700	10500
C7AB-0150-CAV,TAC	001	12	1-1/2	11000	12100	13300	14500	15800
CBAM-0153-CAV,TAC	001	12	1-1/2	13000				
E3AH-A151-CAV,TAC	020	22	1-1/2	11100	12400	13700	15100	16500
C3AH-0150-CAV,TAC,TAD	001	22	1-1/2	11200	12400	13600	14900	16300
EPAK-A150-CAV,TAC	020	134a	1-1/2	11060	12210	13410	14650	15950
CPAK-0150-CAV,TAC	001	134a	1-1/2	11350	12540	13770	15060	16400
C7AB-0200-CAB,TAC,TAD	001	12	2	15200	16600	18100	19700	21300
D8AJ-0200-CAV,TAC	020	22	2	15600	17200	19000	20800	22800
D8AM-0201-TAC,TAD	020	22	2	17510				
C8AJ-0200-CAV,TAC	001	22	2	15000	16500	18100	19800	21600
C3AH-0204-TAD	001	22	2	15000	16500	18100	19800	21600
C3AM-0202-CAB	001	22	2	16500				
C8AM-0202-TAC,TAD	001	22	2	16700				
D8AJ-0200-CAV,TAC	020	404A	2	15900				
D8AM-0201-TAC,TAD	020	404A	2	18700				
C8AJ-0200-CAV,TAC	001	404A	2	15100				
C8AM-0202-TAC,TAD	001	404A	2	17420				
DNAG-0200-CAV,TAC	020	134a	2	15770	17520	19390	21370	23480
CNAG-0200-CAV,TAC	001	134a	2	15000	16600	18300	20100	22000
C7AB-0300-CAB,TAC,TAD	001	12	3	25000	27500	30200	32900	35800
D8AJ-0300-TAC,TAD	020	22	3	26010	28690	31530	34530	37710
C3AH-0303-CAB,TAC,TAD,TAE	001	22	3	26470	29300	32290	35440	38730
C8AJ-0300-TAC,TAD	001	22	3	26470	29300	32290	35440	38730
D8AJ-0300-TAC,TAD	020	404A	3	27400				
C8AJ-0300-TAC,TAD	001	404A	3	28300				
DTAH-0300-CAB	020	134a	3	24170	26520	28990	31560	34190
CTAH-0300-CAB	001	134a	3	25000	27400	29900	32600	35300
CPDK-0300-TFC,TFD,TFE	001	134a	3	33780	37270	40970	44880	48980
C8DJ-0500-TFC,TFD,TFE	001	22	5	41700				
C8DJ-0501-TFC,TFD,TFE	001	22	5	47000	52100	57400	62900	68600
C8DJ-0500-TFC,TFD,TFE	001	404A	5	42980				
C8DJ-0501-TFC,TFD	001	404A	5	49900				
CPDK-0600-TFC,TFD	001	134a	6	45870	50920	56280	61950	67970
CPDK-0601-TFC,TFD	001	134a	6	53780	59480	65520	71890	78580
C8DJ-0750-TFC	001	22	7-1/2	68900	75800	83300	91100	99100
C8DJ-0750-TFC	001	404A	7-1/2	71300				
CPDK-0750-TFC,TFD,TFE	001	134a	7-1/2	61300	67700	74500	81600	89000
CPDK-0900-TFC,TFD	001	134a	9	77700	86100	95100	104700	114900
C8DJ-1000-TFC,TFD	001	22	10	104100	114200	124900	136100	148000
C8DJ-1000-TFC,TFD	001	404A	10	108700				
CPDK-1000-TFC,TFD	001	134a	10	84350	93440	103170	113530	124650

Copelametic® air-cooled condensing units

Capacity Data

HIGH/MED TEMP		Capacity (BTU/Hr) at 100° Ambient - Evaporator Temp (°F)						
Model	BOM	Refrig.	H.P.	-5	0	+10	+15	+20
ENAG-A050-IAA	020	134a	1/2		1740	2190	2430	2700
E8AJ-A075-CAV,TAC	020	22	3/4		3080	3980	4480	5010
E3AM-A075-CAA,CAV,TAC	020	22	3/4	3280	3720	4670	5190	5780
E8AJ-A075-CAV,TAC	020	404A	3/4	2690	3090	4030	4530	5040
ENAG-A075-CAV	020	134a	3/4	2620	3030	3920	4410	4930
C7AB-0100-CAV,TAC,TAD	001	12	1		4180	5270	5880	6530
CBAM-0103-TAC,TAD	001	12	1		4700	5890	6560	7260
C8AJ-0100-CAV,TAC,TAD	001	22	1		4610	5900	6620	7400
C3AM-0101-CAV,TAC,TAD	001	22	1		5210	6780	7630	8540
E8AJ-A100-CAV,TAC,TAD	020	22	1		4380	5600	6270	6990
E3AM-A101-CAV,TAC,TAD	020	22	1		5270	6870	7740	8670
E8AJ-A100-CAV,TAC,TAD	020	404A	1	4310	4790	5970	6590	7190
C8AJ-0100-CAV,TAC,TAD	001	404A	1	4360	4850	6120	6770	7430
CNAG-0100-CAV,TAC	001	134a	1		4210	5310	5930	6600
ENAG-A100-CAV,TAC	020	134a	1		3990	5020	5590	6200
C7AB-0150-CAV,TAC	001	12	1-1/2		5710	7320	8210	9150
CBAM-0153-CAV,TAC	001	12	1-1/2	5950	6770	8650	9670	
E3AH-A151-CAV,TAC	020	22	1-1/2		5790	7250	8160	9170
C3AH-0150-CAV,TAC,TAD	001	22	1-1/2		5640	7380	8310	9310
EPAK-A150-CAV,TAC	020	134a	1-1/2		5850	7420	8310	9270
CPAK-0150-CAV,TAC	001	134a	1-1/2		5870	7540	8480	9470
C7AB-0200-CAB,TAC,TAD	001	12	2		7860	10300	11600	12800
D8AJ-0200-CAV,TAC	020	22	2		7380	10200	11700	13100
D8AM-0201-TAC,TAD	020	22	2	7490	8600	11220	12720	14340
C8AJ-0200-CAV,TAC	001	22	2		7160	9900	11200	12600
C3AH-0204-TAD	001	22	2		7160	9900	11200	12600
C3AM-0202-CAB	001	22	2	7250	8260	10600	12000	13500
C8AM-0202-TAC,TAD	001	22	2	7290	8350	10800	12200	13700
D8AJ-0200-CAV,TAC	020	404A	2	7630	8680	10700	11800	13000
D8AM-0201-TAC,TAD	020	404A	2	8670	9890	12500	13800	15200
C8AJ-0200-CAV,TAC	001	404A	2	7400	8390	10300	11300	12400
C8AM-0202-TAC,TAD	001	404A	2	8270	9370	11740	12950	14230
DNAG-0200-CAV,TAC	020	134a	2		7590	10130	11490	12940
CNAG-0200-CAV,TAC	001	134a	2		7350	9730	11000	12300
C7AB-0300-CAB,TAC,TAD	001	12	3		13600	17000	18900	21000
D8AJ-0300-TAC,TAD	020	22	3		13570	17410	19520	21770
C3AH-0303-CAB,TAC,TAD,TAE	001	22	3		13470	17350	19520	21830
C8AJ-0300-TAC,TAD	001	22	3		13470	17350	19520	21830
D8AJ-0300-TAC,TAD	020	404A	3	12900	14600	18400	20400	22500
C8AJ-0300-TAC,TAD	001	404A	3	13100	14900	18800	21000	23200
DTAH-0300-CAB	020	134a	3		14000	16750	18450	20330
CTAH-0300-CAB	001	134a	3		13600	17200	19100	21100
CPDK-0300-TFC,TFD,TFE	001	134a	3		17500	22550	25280	28190
C8DJ-0500-TFC,TFD,TFE	001	22	5	17200	20300	27000	30700	34500
C8DJ-0501-TFC,TFD,TFE	001	22	5			30500	34700	39000
C8DJ-0500-TFC,TFD,TFE	001	404A	5	20140	22690	28660	31920	35360
C8DJ-0501-TFC,TFD	001	404A	5	24300	27100	33900	37500	41300
CPDK-0600-TFC,TFD	001	134a	6		23330	30230	34080	38200
CPDK-0601-TFC,TFD	001	134a	6		27460	35780	40290	45070
C8DJ-0750-TFC	001	22	7-1/2			47300	52300	58000
C8DJ-0750-TFC	001	404A	7-1/2	36500	40600	49800	54700	59800
CPDK-0750-TFC,TFD,TFE	001	134a	7-1/2		31500	41000	46100	51400
CPDK-0900-TFC,TFD	001	134a	9		39200	51400	58000	64900
C8DJ-1000-TFC,TFD	001	22	10		58000	72400	80300	88700
C8DJ-1000-TFC,TFD	001	404A	10	53800	60500	75000	82800	90800
CPDK-1000-TFC,TFD	001	134a	10		42780	55910	63000	70510

Copelametic® air-cooled condensing units

Capacity Data

HIGH/MED TEMP		Capacity (BTU/Hr) at 100° Ambient - Evaporator Temp (°F)						
Model	BOM	Refrig.	H.P.	+25	+30	+35	+40	+45
ENAG-A050-IAA	020	134a	1/2	2980	3280	3600	3930	4270
E8AJ-A075-CAV,TAC	020	22	3/4	5570	6170	6790	7450	8120
E3AM-A075-CAA,CAV,TAC	020	22	3/4	6420				
E8AJ-A075-CAV,TAC	020	404A	3/4	5550				
ENAG-A075-CAV	020	134a	3/4	5490	6070	6670	7300	
C7AB-0100-CAV,TAC,TAD	001	12	1	7220	7960	8740	9540	10400
CBAM-0103-TAC,TAD	001	12	1	8020				
C8AJ-0100-CAV,TAC,TAD	001	22	1	8210	9070	9960	10900	11800
C3AM-0101-CAV,TAC,TAD	001	22	1	9510				
E8AJ-A100-CAV,TAC,TAD	020	22	1	7750	8540	9350	10200	
E3AM-A101-CAV,TAC,TAD	020	22	1	9650				
E8AJ-A100-CAV,TAC,TAD	020	404A	1	7760				
C8AJ-0100-CAV,TAC,TAD	001	404A	1	8040				
CNAG-0100-CAV,TAC	001	134a	1	7310	8060	8860	9700	10590
ENAG-A100-CAV,TAC	020	134a	1	6840	7510	8210	8930	9670
C7AB-0150-CAV,TAC	001	12	1-1/2	10100	11200	12300	13400	14600
CBAM-0153-CAV,TAC	001	12	1-1/2					
E3AH-A151-CAV,TAC	020	22	1-1/2	10300	11500	12800	14100	15500
C3AH-0150-CAV,TAC,TAD	001	22	1-1/2	10400	11500	12700	13900	15200
EPAK-A150-CAV,TAC	020	134a	1-1/2	10290	11360	12480	13640	14850
CPAK-0150-CAV,TAC	001	134a	1-1/2	10520	11620	12790	14000	15260
C7AB-0200-CAB,TAC,TAD	001	12	2	14100	15500	16800	18300	19800
D8AJ-0200-CAV,TAC	020	22	2	14600	16100	17800	19500	21300
D8AM-0201-TAC,TAD	020	22	2					
C8AJ-0200-CAV,TAC	001	22	2	14000	15400	16900	18500	20200
C3AH-0204-TAD	001	22	2	14000	15400	16900	18500	20200
C3AM-0202-CAB	001	22	2	15100				
C8AM-0202-TAC,TAD	001	22	2	15300				
D8AJ-0200-CAV,TAC	020	404A	2	14400				
D8AM-0201-TAC,TAD	020	404A	2	16800				
C8AJ-0200-CAV,TAC	001	404A	2	13600				
C8AM-0202-TAC,TAD	001	404A	2	15630				
DNAG-0200-CAV,TAC	020	134a	2	14480	16120	17870	19730	21720
CNAG-0200-CAV,TAC	001	134a	2	13800	15300	16800	18500	20300
C7AB-0300-CAB,TAC,TAD	001	12	3	23200	25500	27900	30400	33100
D8AJ-0300-TAC,TAD	020	22	3	24150	26690	29370	32200	35210
C3AH-0303-CAB, TAC, TAD, TAE	001	22	3	24300	26910	29680	32600	35640
C8AJ-0300-TAC,TAD	001	22	3	24300	26910	29680	32600	35640
D8AJ-0300-TAC,TAD	020	404A	3	24800				
C8AJ-0300-TAC,TAD	001	404A	3	25600				
DTAH-0300-CAB	020	134a	3	22370	24560	26860	29250	31720
CTAH-0300-CAB	001	134a	3	23200	25400	27700	30200	32700
CPDK-0300-TFC,TFD,TFE	001	134a	3	31270	34540	38010	41700	45580
C8DJ-0500-TFC,TFD,TFE	001	22	5	38500				
C8DJ-0501-TFC,TFD,TFE	001	22	5	43600	48400	53400	58700	64100
C8DJ-0500-TFC,TFD,TFE	001	404A	5	38970				
C8DJ-0501-TFC,TFD	001	404A	5	45300				
CPDK-0600-TFC,TFD	001	134a	6	42610	47320	52330	57620	63260
CPDK-0601-TFC,TFD	001	134a	6	50120	55470	61130	67100	73370
C8DJ-0750-TFC	001	22	7-1/2	64100	70700	77600	84800	92400
C8DJ-0750-TFC	001	404A	7-1/2	65100				
CPDK-0750-TFC,TFD,TFE	001	134a	7-1/2	57100	63100	69400	76000	83000
CPDK-0900-TFC,TFD	001	134a	9	72300	80100	88600	97600	107300
C8DJ-1000-TFC,TFD	001	22	10	97700	107200	117300	127900	139100
C8DJ-1000-TFC,TFD	001	404A	10	99400				
CPDK-1000-TFC,TFD	001	134a	10	78510	87060	96210	105980	116480

Copelametic® air-cooled condensing units

Capacity Data

HIGH/MED TEMP		Capacity (BTU/Hr) at 110° Ambient - Evaporator Temp (°F)						
Model	BOM	Refrig.	H.P.	-5	0	+10	+15	+20
ENAG-A050-IAA	020	134a	1/2		1580	1990	2220	2460
E8AJ-A075-CAV,TAC	020	22	3/4		2780	3610	4070	4560
E3AM-A075-CAA,CAV,TAC	020	22	3/4	2970	3360	4220	4710	5240
E8AJ-A075-CAV,TAC	020	404A	3/4	2300	2660	3520	3960	4410
ENAG-A075-CAV	020	134a	3/4	2360	2720	3540	3990	4460
C7AB-0100-CAV,TAC,TAD	001	12	1		3790	4790	5340	5940
CBAM-0103-TAC,TAD	001	12	1		4250	5340	5940	6590
C8AJ-0100-CAV,TAC,TAD	001	22	1		4150	5370	6050	6780
C3AM-0101-CAV,TAC,TAD	001	22	1		4730	6180	6980	7830
E8AJ-A100-CAV,TAC,TAD	020	22	1		3950	5100	5740	6410
E3AM-A101-CAV,TAC,TAD	020	22	1		4780	6270	7080	7950
E8AJ-A100-CAV,TAC,TAD	020	404A	1	3780	4190	5260	5820	6360
C8AJ-0100-CAV,TAC,TAD	001	404A	1	3830	4250	5400	6000	6590
CNAG-0100-CAV,TAC	001	134a	1		3830	4840	5410	6020
ENAG-A100-CAV,TAC	020	134a	1		3620	4560	5080	5630
C7AB-0150-CAV,TAC	001	12	1-1/2		5150	6640	7470	8350
CBAM-0153-CAV,TAC	001	12	1-1/2	5350	6110			
E3AH-A151-CAV,TAC	020	22	1-1/2		5320	6660	7510	8470
C3AH-0150-CAV,TAC,TAD	001	22	1-1/2		5170	6780	7650	8580
EPAK-A150-CAV,TAC	020	134a	1-1/2		5390	6830	7650	8530
CPAK-0150-CAV,TAC	001	134a	1-1/2		5320	6870	7740	8660
C7AB-0200-CAB,TAC,TAD	001	12	2		7370	9620	10700	11900
D8AJ-0200-CAV,TAC	020	22	2		6650	9440	10800	12200
D8AM-0201-TAC,TAD	020	22	2	14680				
C8AJ-0200-CAV,TAC	001	22	2		6440	9100	10400	11700
C3AH-0204-TAD	001	22	2		6440	9100	10400	11700
C3AM-0202-CAB	001	22	2	6510	7420	9580	10800	12200
C8AM-0202-TAC,TAD	001	22	2	6560	7560	9870	11200	12500
D8AJ-0200-CAV,TAC	020	404A	2	6840	7790	9590	10500	11600
D8AM-0201-TAC,TAD	020	404A	2	7550	8660	11000	12200	13500
C8AJ-0200-CAV,TAC	001	404A	2	6620	7510	9190	10000	11000
C8AM-0202-TAC,TAD	001	404A	2	7190	8190	10320	11410	12570
DNAG-0200-CAV,TAC	020	134a	2		6810	9150	10410	11750
CNAG-0200-CAV,TAC	001	134a	2		6590	8790	9970	11200
C7AB-0300-CAB,TAC,TAD	001	12	3		12500	15600	17300	19200
D8AJ-0300-TAC,TAD	020	22	3		12300	15970	17970	20090
C3AH-0303-CAB,TAC,TAD,TAE	001	22	3		12190	15740	17720	19840
C8AJ-0300-TAC,TAD	001	22	3		12190	15740	17720	19840
D8AJ-0300-TAC,TAD	020	404A	3	11400	12900	16400	18200	20100
C8AJ-0300-TAC,TAD	001	404A	3	11500	13100	16700	18600	20700
DTAH-0300-CAB	020	134a	3		12870	15340	16890	18610
CTAH-0300-CAB	001	134a	3		12600	15900	17600	19500
CPDK-0300-TFC,TFD,TFE	001	134a	3		15920	20670	23230	25950
C8DJ-0500-TFC,TFD,TFE	001	22	5		18100	24500	28000	31600
C8DJ-0501-TFC,TFD,TFE	001	22	5			28000	31900	36000
C8DJ-0500-TFC,TFD,TFE	001	404A	5	18060	20330	25740	28680	31790
C8DJ-0501-TFC,TFD	001	404A	5	22000	24500	30400	33700	37100
CPDK-0600-TFC,TFD	001	134a	6		21390	27820	31410	35250
CPDK-0601-TFC,TFD	001	134a	6		24990	32950	37240	41760
C8DJ-0750-TFC	001	22	7-1/2			43900	48600	53800
C8DJ-0750-TFC	001	404A	7-1/2	32800	36700	45100	49600	54200
CPDK-0750-TFC,TFD,TFE	001	134a	7-1/2		28600	37700	42500	47600
CPDK-0900-TFC,TFD	001	134a	9		35800	47400	53600	60100
C8DJ-1000-TFC,TFD	001	22	10		53800	67400	74900	82800
C8DJ-1000-TFC,TFD	001	404A	10	48400	54500	67900	75000	82300
CPDK-1000-TFC,TFD	001	134a	10		39230	51660	58340	65400

Copelametic® air-cooled condensing units

Capacity Data

HIGH/MED TEMP		Capacity (BTU/Hr) at 110° Ambient - Evaporator Temp (°F)						
Model	BOM	Refrig.	H.P.	+25	+30	+35	+40	+45
ENAG-A050-IAA	020	134a	1/2	2720	2990	3280	3590	
E8AJ-A075-CAV,TAC	020	22	3/4	5080	5630	6210		
E3AM-A075-CAA,CAV,TAC	020	22	3/4	5850				
E8AJ-A075-CAV,TAC	020	404A	3/4	4860				
ENAG-A075-CAV	020	134a	3/4	4960	5490	6040	6620	3650
C7AB-0100-CAV,TAC,TAD	001	12	1	6580	7250	7960	8700	9480
CBAM-0103-TAC,TAD	001	12	1	7280				
C8AJ-0100-CAV,TAC,TAD	001	22	1	7540				
C3AM-0101-CAV,TAC,TAD	001	22	1	8750				
E8AJ-A100-CAV,TAC,TAD	020	22	1	7120				
E3AM-A101-CAV,TAC,TAD	020	22	1	8880				
E8AJ-A100-CAV,TAC,TAD	020	404A	1	6880				
C8AJ-0100-CAV,TAC,TAD	001	404A	1	7150				
CNAG-0100-CAV,TAC	001	134a	1	6670	7360	8090	8860	9670
ENAG-A100-CAV,TAC	020	134a	1	6220	6830			
C7AB-0150-CAV,TAC	001	12	1-1/2	9280	10300	11300	12300	
CBAM-0153-CAV,TAC	001	12	1-1/2					
E3AH-A151-CAV,TAC	020	22	1-1/2	9520	10700	11900		
C3AH-0150-CAV,TAC,TAD	001	22	1-1/2	9560	10600	0		
EPAK-A150-CAV,TAC	020	134a	1-1/2	9470	10460	11490		
CPAK-0150-CAV,TAC	001	134a	1-1/2	9640	10680	11760	12900	
C7AB-0200-CAB,TAC,TAD	001	12	2	13000	14200	15500		
D8AJ-0200-CAV,TAC	020	22	2	13600	15000	16500	18100	
D8AM-0201-TAC,TAD	020	22	2					
C8AJ-0200-CAV,TAC	001	22	2	13000	14300			
C3AH-0204-TAD	001	22	2	13000	14300			
C3AM-0202-CAB	001	22	2	13800				
C8AM-0202-TAC,TAD	001	22	2	14000				
D8AJ-0200-CAV,TAC	020	404A	2	12800				
D8AM-0201-TAC,TAD	020	404A	2	14900				
C8AJ-0200-CAV,TAC	001	404A	2	12200				
C8AM-0202-TAC,TAD	001	404A	2	13850				
DNAG-0200-CAV,TAC	020	134a	2	13180	14700	16330	18070	
CNAG-0200-CAV,TAC	001	134a	2	12500	13900			
C7AB-0300-CAB,TAC,TAD	001	12	3	21200	23300	25500	27800	30300
D8AJ-0300-TAC,TAD	020	22	3	22330	24720	27250	29920	
C3AH-0303-CAB, TAC, TAD, TAE	001	22	3	22090	24490	27020	29700	32500
C8AJ-0300-TAC,TAD	001	22	3	22090	24490	27020	29700	32500
D8AJ-0300-TAC,TAD	020	404A	3	22100				
C8AJ-0300-TAC,TAD	001	404A	3	22900				
DTAH-0300-CAB	020	134a	3	20500	22520	24650	26890	
CTAH-0300-CAB	001	134a	3	21400	23400	25500	27800	30100
CPDK-0300-TFC,TFD,TFE	001	134a	3	28840	31910			
C8DJ-0500-TFC,TFD,TFE	001	22	5	35400				
C8DJ-0501-TFC,TFD,TFE	001	22	5	40400				
C8DJ-0500-TFC,TFD,TFE	001	404A	5	35050				
C8DJ-0501-TFC,TFD	001	404A	5	40600				
CPDK-0600-TFC,TFD	001	134a	6	39360	43750	48420	53380	58660
CPDK-0601-TFC,TFD	001	134a	6	46520	51550	56850	62460	68330
C8DJ-0750-TFC	001	22	7-1/2	59400	65500			
C8DJ-0750-TFC	001	404A	7-1/2	59000				
CPDK-0750-TFC,TFD,TFE	001	134a	7-1/2	52900	58500	64400		
CPDK-0900-TFC,TFD	001	134a	9	67100	74500	82400	90900	100100
C8DJ-1000-TFC,TFD	001	22	10	91300	100200	109700	119700	130200
C8DJ-1000-TFC,TFD	001	404A	10	90000				
CPDK-1000-TFC,TFD	001	134a	10	72910	80940	89550	98750	108670

Copelametic® air-cooled condensing units

Capacity Data

LOW TEMP		Capacity (BTU/Hr) at 90° Ambient - Evaporator Temp (°F)						
Model	BOM	Refrig.	H.P.	-40	-35	-30	-25	-20
ENAG-A050-IAA	020	R-22	1/2	730	930	1160	1420	1710
E8AL-A050-CAV	020	R-22	1/2	730	930	1160	1420	1710
ENAG-A050-IAA	020	R-404A	1/2	880	1100	1360	1650	1970
E8AL-A050-CAV	020	R-404A	1/2	880	1100	1360	1650	1970
EJAL-A050-CAV, IAA, TAC	020	R-404A	1/2	880	1100	1360	1650	1970
ENAG-A075-CAV	020	R-22	3/4	1670	2000	2370	2790	3250
E8AL-A075-CAA, TAC	020	R-22	3/4	1870	2300	2760	3260	3810
ENAG-A075-CAV	020	R-404A	3/4	1920	2160	2490	2900	3370
E8AL-A075-CAA, TAC	020	R-404A	3/4	1920	2160	2490	2900	3370
ENAG-A100-CAV, TAC	020	R-22	1	2110	2500	2950	3460	4010
CNAG-0100-CAV, TAC	001	R-22	1	2210	2660	3140	3670	4250
ENAG-A100-CAV, TAC	020	R-404A	1	2430	2880	3370	3900	4470
CNAG-0100-CAV, TAC	001	R-404A	1	2430	2900	3410	3960	4550
CLAL-0152-CAB	001	R-22	1-1/2	3110	3890	4730	5640	6630
C8AL-0151-TAC	001	R-22	1-1/2	3410	4180	5020	5930	6910
EPAK-A150-CAV, TAC	020	R-404A	1-1/2	3610	4290	5020	5800	6630
EJAL-A150-TAD	020	R-404A	1-1/2	3390	4190	4980	5770	6580
CPAK-0150-CAV, TAC	001	R-404A	1-1/2	3690	4390	5140	5960	6830
CJAL-0152-TAD	001	R-404A	1-1/2	3470	4300	5120	5940	6790
CJAL-0153-CAB	001	R-404A	1-1/2	3990	4730	5580	6520	7560
C8AL-0151-TAC	001	R-404A	1-1/2	3850	4690	5570	6500	7490
DNAG-0200-CAV, TAC	020	R-22	2	4160	4790	5670	6770	8040
CNAG-0200-CAV, TAC	001	R-22	2	4110	4720	5570	6620	7820
C8AL-0200-TAD	001	R-22	2	4120	4730	5580	6630	7850
DNAG-0200-CAV, TAC	020, 050	R-404A	2	4280	5170	6210	7390	8690
CNAG-0200-CAV, TAC	001	R-404A	2	4180	5020	6010	7120	8340
C8AL-0200-TAD	001	R-404A	2	4180	5020	6010	7120	8340
DLAL-0301-CAB, TAC, TAD	020	R-22	3	5570	6930	8510	10300	12300
CLAL-0300-CAB, TAC, TAD	001	R-22	3	5590	6960	8570	10400	12400
DJAL-0300-TAD	020	R-404A	3	6380	7980	9770	11700	13800
CJAL-0300-CAB, TAC, TAD, TAE	001	R-404A	3	6790	8510	10420	12530	14820
CPDK-0300-TFC, TFD, TFE	001	R-404A	3	10400	12300	14400	16700	19200
CMDL-0400-TFC	001	R-22	4	9630	11700	14100	16700	19700
CJDL-0400-TFC, TFD, TFE	001	R-404A	4	12990	15350	17900	20650	23590
CPDK-0600-TFC, TFD	001	R-404A	6	15800	18600	21500	24700	28100
CPDK-0601-TFC, TFD	001	R-404A	6	19070	22130	25500	29180	33150
CPDK-0750-TFC, TFD, TFE	001	R-404A	7-1/2	22300	25900	29900	34000	38500
CPDK-0900-TFC, TFD	001	R-404A	9	28000	32600	37600	43200	49200
CPDK-1000-TFC, TFD	001	R-404A	10	31730	36870	42460	48490	54970

LT & MT models are rated at 40° F return gas temperature

HT models are rated at 65° F return gas temperature

Copelametic® air-cooled condensing units

Capacity Data

LOW TEMP		Capacity (BTU/Hr) at 90° Ambient - Evaporator Temp (°F)					
Model	BOM	Refrig.	H.P.	-15	-10	-5	0
ENAG-A050-IAA	020	R-22	1/2	2030	2370	2720	3080
E8AL-A050-CAV	020	R-22	1/2	2030	2370	2720	3080
ENAG-A050-IAA	020	R-404A	1/2	2300	2660	3030	3370
E8AL-A050-CAV	020	R-404A	1/2	2300	2660	3030	3370
EJAL-A050-CAV, IAA, TAC	020	R-404A	1/2	2300	2660	3030	3370
ENAG-A075-CAV	020	R-22	3/4	3740	4260	4820	5380
E8AL-A075-CAA, TAC	020	R-22	3/4	4390	5010	5670	6360
ENAG-A075-CAV	020	R-404A	3/4	3880	4430	4990	5510
E8AL-A075-CAA, TAC	020	R-404A	3/4	3880	4430	4990	5510
ENAG-A100-CAV, TAC	020	R-22	1	4610	5260	5940	6640
CNAG-0100-CAV, TAC	001	R-22	1	4870	5540	6280	7060
ENAG-A100-CAV, TAC	020	R-404A	1	5060	5700	6370	7060
CNAG-0100-CAV, TAC	001	R-404A	1	5190	5870	6590	7310
CLAL-0152-CAB	001	R-22	1-1/2	7690	8840	10100	11400
C8AL-0151-TAC	001	R-22	1-1/2	7960	9100	10300	11600
EPAK-A150-CAV, TAC	020	R-404A	1-1/2	7510	8450	9430	10400
EJAL-A150-TAD	020	R-404A	1-1/2	7410	8280	9200	10100
CPAK-0150-CAV, TAC	001	R-404A	1-1/2	7760	8750	9810	10900
CJAL-0152-TAD	001	R-404A	1-1/2	7670	8600	9590	10600
CJAL-0153-CAB	001	R-404A	1-1/2	8680	9900	11200	12500
C8AL-0151-TAC	001	R-404A	1-1/2	8560	9720	11000	12300
DNAG-0200-CAV, TAC	020	R-22	2	9450	11000	12500	14100
CNAG-0200-CAV, TAC	001	R-22	2	9140	10600	12000	13400
C8AL-0200-TAD	001	R-22	2	9180	10600	12100	13500
DNAG-0200-CAV, TAC	020, 050	R-404A	2	10090	11570	13110	14630
CNAG-0200-CAV, TAC	001	R-404A	2	9630	11000	12410	13750
C8AL-0200-TAD	001	R-404A	2	9630	11000	12400	13800
DLAL-0301-CAB, TAC, TAD	020	R-22	3	14400	16700	19100	21500
CLAL-0300-CAB, TAC, TAD	001	R-22	3	14600	16900	19400	21900
DJAL-0300-TAD	020	R-404A	3	16000	18300	20700	23000
CJAL-0300-CAB, TAC, TAD, TAE	001	R-404A	3	17270	19880	22630	25370
CPDK-0300-TFC, TFD, TFE	001	R-404A	3	21800	24500	27500	30300
CMDL-0400-TFC	001	R-22	4	22800	26200	29800	33600
CJDL-0400-TFC, TFD, TFE	001	R-404A	4	26710	30040	33570	37160
CPDK-0600-TFC, TFD	001	R-404A	6	31700	35600	39700	44000
CPDK-0601-TFC, TFD	001	R-404A	6	37400	41940	46740	51680
CPDK-0750-TFC, TFD, TFE	001	R-404A	7-1/2	43200	48200	53500	59000
CPDK-0900-TFC, TFD	001	R-404A	9	55600	62600	70100	78000
CPDK-1000-TFC, TFD	001	R-404A	10	61840	69150	76850	84800

Copelametic® air-cooled condensing units

Capacity Data

LOW TEMP		Capacity (BTU/Hr) at 100° Ambient - Evaporator Temp (°F)						
Model	BOM	Refrig.	H.P.	-40	-35	-30	-25	-20
ENAG-A050-IAA	020	R-22	1/2	560	750	980	1,230	1,500
E8AL-A050-CAV	020	R-22	1/2	560	750	980	1,230	1,500
ENAG-A050-IAA	020	R-404A	1/2	670	880	1,120	1,390	1,680
E8AL-A050-CAV	020	R-404A	1/2	670	880	1,120	1,390	1,680
EJAL-A050-CAV, IAA, TAC	020	R-404A	1/2	670	880	1,120	1,390	1,680
ENAG-A075-CAV	020	R-22	3/4	1,500	1,810	2,160	2,550	2,980
E8AL-A075-CAA, TAC	020	R-22	3/4	1,580	1,990	2,430	2,910	3,420
ENAG-A075-CAV	020	R-404A	3/4	1,620	1,850	2,160	2,550	2,980
E8AL-A075-CAA, TAC	020	R-404A	3/4	1,620	1,850	2,160	2,550	2,980
ENAG-A100-CAV, TAC	020	R-22	1	1,860	2,220	2,640	3,120	3,630
CNAG-0100-CAV, TAC	001	R-22	1	1,970	2,400	2,860	3,360	3,890
ENAG-A100-CAV, TAC	020	R-404A	1	2,070	2,480	2,920	3,400	3,920
CNAG-0100-CAV, TAC	001	R-404A	1	2,070	2,490	2,950	3,450	3,990
CLAL-0152-CAB	001	R-22	1-1/2	2,670	3,390	4,170	5,010	5,920
C8AL-0151-TAC	001	R-22	1-1/2	3,000	3,710	4,480	5,320	6,220
EPAK-A150-CAV, TAC	020	R-404A	1-1/2	3,080	3,730	4,410	5,150	5,920
EJAL-A150-TAD	020	R-404A	1-1/2	2,730	3,530	4,300	5,050	5,810
CPAK-0150-CAV, TAC	001	R-404A	1-1/2	3,150	3,820	4,540	5,300	6,120
CJAL-0152-TAD	001	R-404A	1-1/2	2,820	3,640	4,430	5,220	6,020
CJAL-0153-CAB	001	R-404A	1-1/2	3,360	4,010	4,760	5,600	6,530
C8AL-0151-TAC	001	R-404A	1-1/2	3,190	4,010	4,840	5,700	6,620
DNAG-0200-CAV, TAC	020	R-22	2	3,760	4,330	5,130	6,140	7,320
CNAG-0200-CAV, TAC	001	R-22	2	3,720	4,260	5,030	5,980	7,080
C8AL-0200-TAD	001	R-22	2	3,730	4,270	5,040	6,000	7,110
DNAG-0200-CAV, TAC	020, 050	R-404A	2	3,690	4,470	5,410	6,470	7,660
CNAG-0200-CAV, TAC	001	R-404A	2	3,620	4,370	5,250	6,260	7,360
C8AL-0200-TAD	001	R-404A	2	3,620	4,370	5,250	6,260	7,360
DLAL-0301-CAB, TAC, TAD	020	R-22	3	5,020	6,280	7,750	9,410	11,200
CLAL-0300-CAB, TAC, TAD	001	R-22	3	5,060	6,330	7,820	9,500	11,400
DJAL-0300-TAD	020	R-404A	3	4,990	6,560	8,270	10,100	12,100
CJAL-0300-CAB, TAC, TAD, TAE	001	R-404A	3	5,550	7,090	8,830	10,760	12,870
CPDK-0300-TFC, TFD, TFE	001	R-404A	3	8,860	10,800	12,800	15,000	17,300
CMDL-0400-TFC	001	R-22	4	8,360	10,300	12,500	15,000	17,700
CJDL-0400-TFC, TFD, TFE	001	R-404A	4	11,380	13,610	16,000	18,560	21,280
CPDK-0600-TFC, TFD	001	R-404A	6	13,900	16,600	19,400	22,300	25,500
CPDK-0601-TFC, TFD	001	R-404A	6	16,980	19,960	23,190	26,670	30,390
CPDK-0750-TFC, TFD, TFE	001	R-404A	7-1/2	19,900	23,500	27,300	31,200	35,400
CPDK-0900-TFC, TFD	001	R-404A	9	25,300	29,700	34,500	39,700	45,300
CPDK-1000-TFC, TFD	001	R-404A	10	28,440	33,360	38,660	44,340	50,400

LT & MT models are rated at 40° F return gas temperature

HT models are rated at 65° F return gas temperature

Copelametic® air-cooled condensing units

Capacity Data

LOW TEMP		Capacity (BTU/Hr) at 100° Ambient - Evaporator Temp (°F)					
Model	BOM	Refrig.	H.P.	-15	-10	-5	0
ENAG-A050-IAA	020	R-22	1/2	1,800	2,110	2,440	2,770
E8AL-A050-CAV	020	R-22	1/2	1,800	2,110	2,440	2,770
ENAG-A050-IAA	020	R-404A	1/2	1,980	2,300	2,630	2,920
E8AL-A050-CAV	020	R-404A	1/2	1,980	2,300	2,630	2,920
EJAL-A050-CAV, IAA, TAC	020	R-404A	1/2	1,980	2,300	2,630	2,920
ENAG-A075-CAV	020	R-22	3/4	3,430	3,910	4,410	4,920
E8AL-A075-CAA, TAC	020	R-22	3/4	3,960	4,550	5,170	5,810
ENAG-A075-CAV	020	R-404A	3/4	3,460	3,960	4,460	4,930
E8AL-A075-CAA, TAC	020	R-404A	3/4	3,460	3,960	4,460	4,930
ENAG-A100-CAV, TAC	020	R-22	1	4,190	4,790	5,420	6,070
CNAG-0100-CAV, TAC	001	R-22	1	4,470	5,090	5,780	6,490
ENAG-A100-CAV, TAC	020	R-404A	1	4,460	5,040	5,660	6,280
CNAG-0100-CAV, TAC	001	R-404A	1	4,570	5,190	5,850	6,510
CLAL-0152-CAB	001	R-22	1-1/2	6,910	7,980	9,140	10,400
C8AL-0151-TAC	001	R-22	1-1/2	7,190	8,250	9,380	10,600
EPAK-A150-CAV, TAC	020	R-404A	1-1/2	6,730	7,590	8,490	9,360
EJAL-A150-TAD	020	R-404A	1-1/2	6,570	7,370	8,200	9,000
CPAK-0150-CAV, TAC	001	R-404A	1-1/2	6,970	7,890	8,850	9,810
CJAL-0152-TAD	001	R-404A	1-1/2	6,830	7,680	8,570	9,470
CJAL-0153-CAB	001	R-404A	1-1/2	7,560	8,680	9,890	11,100
C8AL-0151-TAC	001	R-404A	1-1/2	7,600	8,660	9,800	11,000
DNAG-0200-CAV, TAC	020	R-22	2	8,610	10,000	11,500	12,900
CNAG-0200-CAV, TAC	001	R-22	2	8,280	9,560	10,900	12,200
C8AL-0200-TAD	001	R-22	2	8,320	9,610	11,000	12,300
DNAG-0200-CAV, TAC	020, 050	R-404A	2	8,930	10,280	11,680	13,060
CNAG-0200-CAV, TAC	001	R-404A	2	8,540	9,780	11,070	12,290
C8AL-0200-TAD	001	R-404A	2	8,540	9,780	11,100	12,300
DLAL-0301-CAB, TAC, TAD	020	R-22	3	13,200	15,300	17,500	19,700
CLAL-0300-CAB, TAC, TAD	001	R-22	3	13,400	15,500	17,800	20,100
DJAL-0300-TAD	020	R-404A	3	14,100	16,200	18,400	20,500
CJAL-0300-CAB, TAC, TAD, TAE	001	R-404A	3	15,140	17,570	20,140	22,710
CPDK-0300-TFC, TFD, TFE	001	R-404A	3	19,700	22,200	24,900	27,500
CMDL-0400-TFC	001	R-22	4	20,700	23,900	27,300	30,800
CJDL-0400-TFC, TFD, TFE	001	R-404A	4	24,170	27,240	30,490	33,790
CPDK-0600-TFC, TFD	001	R-404A	6	28,800	32,400	36,200	40,100
CPDK-0601-TFC, TFD	001	R-404A	6	34,340	38,540	42,960	47,470
CPDK-0750-TFC, TFD, TFE	001	R-404A	7-1/2	39,800	44,500	49,300	54,300
CPDK-0900-TFC, TFD	001	R-404A	9	51,300	57,800	64,700	71,900
CPDK-1000-TFC, TFD	001	R-404A	10	56,790	63,560	70,680	78,000

Copelametic® air-cooled condensing units

Capacity Data

LOW TEMP		Capacity (BTU/Hr) at 110° Ambient - Evaporator Temp (°F)						
Model	BOM	Refrig.	H.P.	-40	-35	-30	-25	-20
ENAG-A050-IAA	020	R-22	1/2	390	580	800	1,040	1,310
E8AL-A050-CAV	020	R-22	1/2	390	580	800	1,040	1,310
ENAG-A050-IAA	020	R-404A	1/2	450	640	860	1,100	1,360
E8AL-A050-CAV	020	R-404A	1/2	450	640	860	1,100	1,360
EJAL-A050-CAV, IAA, TAC	020	R-404A	1/2	450	640	860	1,100	1,360
ENAG-A075-CAV	020	R-22	3/4	1,300	1,590	1,920	2,280	2,670
E8AL-A075-CAA,TAC	020	R-22	3/4	1,290	1,680	2,110	2,560	3,040
ENAG-A075-CAV	020	R-404A	3/4	1,250	1,470	1,760	2,110	2,510
E8AL-A075-CAA,TAC	020	R-404A	3/4	1,250	1,470	1,760	2,110	2,510
ENAG-A100-CAV,TAC	020	R-22	1	1,610	1,950	2,340	2,780	3,260
CNAG-0100-CAV,TAC	001	R-22	1	1,720	2,130	2,560	3,030	3,520
ENAG-A100-CAV,TAC	020	R-404A	1	1,720	2,090	2,480	2,910	3,370
CNAG-0100-CAV,TAC	001	R-404A	1	1,720	2,090	2,500	2,950	3,430
CLAL-0152-CAB	001	R-22	1-1/2	2,220	2,890	3,610	4,390	5,250
C8AL-0151-TAC	001	R-22	1-1/2	2,590	3,240	3,940	4,710	5,540
EPAK-A150-CAV,TAC	020	R-404A	1-1/2	2,470	3,090	3,740	4,420	5,130
EJAL-A150-TAD	020	R-404A	1-1/2	1,980	2,780	3,540	4,270	4,990
CPAK-0150-CAV,TAC	001	R-404A	1-1/2	2,550	3,200	3,870	4,590	5,340
CJAL-0152-TAD	001	R-404A	1-1/2	2,060	2,890	3,680	4,440	5,190
CJAL-0153-CAB	001	R-404A	1-1/2	2,940	3,470	4,090	4,820	5,640
C8AL-0151-TAC	001	R-404A	1-1/2	2,530	3,310	4,090	4,890	5,720
DNAG-0200-CAV,TAC	020	R-22	2	3,230	3,730	4,460	5,380	6,460
CNAG-0200-CAV,TAC	001	R-22	2	3,200	3,670	4,350	5,200	6,190
C8AL-0200-TAD	001	R-22	2	3,200	3,680	4,370	5,230	6,220
DNAG-0200-CAV,TAC	020, 050	R-404A	2	3,290	3,940	4,740	5,680	6,720
CNAG-0200-CAV,TAC	001	R-404A	2	3,240	3,870	4,630	5,510	6,490
C8AL-0200-TAD	001	R-404A	2	3,240	3,870	4,630	5,510	6,490
DLAL-0301-CAB,TAC,TAD	020	R-22	3	4,280	5,450	6,810	8,340	10,000
CLAL-0300-CAB,TAC,TAD	001	R-22	3	4,330	5,520	6,900	8,450	10,200
DJAL-0300-TAD	020	R-404A	3	3,570	5,110	6,750	8,490	10,300
CJAL-0300-CAB,TAC,TAD, TAE	001	R-404A	3	4,180	5,550	7,120	8,870	10,810
CPDK-0300-TFC,TFD,TFE	001	R-404A	3	7,180	9,090	11,100	13,200	15,300
CMDL-0400-TFC	001	R-22	4	7,000	8,770	10,800	13,100	15,700
CJDL-0400-TFC,TFD,TFE	001	R-404A	4	9,790	11,900	14,130	16,500	19,010
CPDK-0600-TFC,TFD	001	R-404A	6	12,000	14,500	17,200	20,000	22,900
CPDK-0601-TFC,TFD	001	R-404A	6	14,540	17,460	20,580	23,880	27,390
CPDK-0750-TFC,TFD,TFE	001	R-404A	7-1/2	17,300	20,900	24,600	28,400	32,300
CPDK-0900-TFC,TFD	001	R-404A	9	22,600	26,800	31,400	36,300	41,500
CPDK-1000-TFC,TFD	001	R-404A	10	25,120	29,850	34,900	40,260	45,920

LT & MT models are rated at 40° F return gas temperature

HT models are rated at 65° F return gas temperature

Copelametic® air-cooled condensing units

Capacity Data

LOW TEMP		Capacity (BTU/Hr) at 110° Ambient - Evaporator Temp (°F)					
Model	BOM	Refrig.	H.P.	-15	-10	-5	0
ENAG-A050-IAA	020	R-22	1/2	1,580	1,870		
E8AL-A050-CAV	020	R-22	1/2	1,580	1,870		
ENAG-A050-IAA	020	R-404A	1/2	1,630	1,900	2,180	
E8AL-A050-CAV	020	R-404A	1/2	1,630	1,900	2,180	
EJAL-A050-CAV, IAA, TAC	020	R-404A	1/2	1,630	1,900	2,180	
ENAG-A075-CAV	020	R-22	3/4	3,090	3,520		
E8AL-A075-CAA, TAC	020	R-22	3/4	3,550			
ENAG-A075-CAV	020	R-404A	3/4	2,940	3,390	3,850	
E8AL-A075-CAA, TAC	020	R-404A	3/4	2,940	3,390	3,850	
ENAG-A100-CAV, TAC	020	R-22	1	3,780	4,330		
CNAG-0100-CAV, TAC	001	R-22	1	4,050	4,630		
ENAG-A100-CAV, TAC	020	R-404A	1	3,850	4,370		
CNAG-0100-CAV, TAC	001	R-404A	1	3,940	4,500	5,100	
CLAL-0152-CAB	001	R-22	1-1/2	6,180	7,190	8,290	
C8AL-0151-TAC	001	R-22	1-1/2	6,440	7,420	8,480	
EPAK-A150-CAV, TAC	020	R-404A	1-1/2	5,870	6,660		
EJAL-A150-TAD	020	R-404A	1-1/2	5,700	6,430		
CPAK-0150-CAV, TAC	001	R-404A	1-1/2	6,130	6,970	7,850	8,710
CJAL-0152-TAD	001	R-404A	1-1/2	5,950	6,730	7,540	8,340
CJAL-0153-CAB	001	R-404A	1-1/2	6,550	7,560	8,670	
C8AL-0151-TAC	001	R-404A	1-1/2	6,610	7,570	8,600	
DNAG-0200-CAV, TAC	020	R-22	2	7,640	8,910	10,200	
CNAG-0200-CAV, TAC	001	R-22	2	7,270	8,420		
C8AL-0200-TAD	001	R-22	2	7,310	8,470		
DNAG-0200-CAV, TAC	020, 050	R-404A	2	7,850	9,060	10,320	11,550
CNAG-0200-CAV, TAC	001	R-404A	2	7,540	8,650		
C8AL-0200-TAD	001	R-404A	2	7,540	8,650		
DLAL-0301-CAB, TAC, TAD	020	R-22	3	11,800	13,700	15,700	
CLAL-0300-CAB, TAC, TAD	001	R-22	3	12,000	14,000	16,100	18,200
DJAL-0300-TAD	020	R-404A	3	12,200	14,100	16,100	
CJAL-0300-CAB, TAC, TAD, TAE	001	R-404A	3	12,900	15,150	17,550	19,930
CPDK-0300-TFC, TFD, TFE	001	R-404A	3	17,600	19,900		
CMDL-0400-TFC	001	R-22	4	18,500	21,500	24,700	
CJDL-0400-TFC, TFD, TFE	001	R-404A	4	21,650	24,460	27,430	
CPDK-0600-TFC, TFD	001	R-404A	6	26,000	29,200	32,700	36,300
CPDK-0601-TFC, TFD	001	R-404A	6	31,060	34,940	38,990	43,100
CPDK-0750-TFC, TFD, TFE	001	R-404A	7-1/2	36,400	40,700		
CPDK-0900-TFC, TFD	001	R-404A	9	47,100	53,000	59,400	66,000
CPDK-1000-TFC, TFD	001	R-404A	10	51,870	58,130	64,700	71,410

Copelametic® air-cooled condensing units

Physical Data

HIGH/MED TEMP Model	Comp	Oil	Overall Dimensions (In)			Connecting Lines		Minimum Circuit Ampacity - Max Fuse Size					Pump Down Capacity (lbs)	Ship Weight (lbs)	
			L	W	H	Suction	Liquid	115-1	230-1	230-3	460-3	575-3			
ENAG-A050	KANB-005E	POE	19.5	16.3	12.1	1/2 S	1/4 S	10.6 - 15.0						2.5	130
E8AJ-A075	KAN*-007E	POE	24	18.0	13.2	5/8 S	3/8 S	7.9 - 15.0	4.9 - 15.0					8.9	190
E3AM-A075	KAE*-0075	MIN	24	18.0	13.2	5/8 S	3/8 S	15.6 - 20.0	7.9 - 15.0	5.4 - 15.0				8.9	160
E8AJ-A075	KAN*-007E	POE	24	17.9	13.2	5/8 S	3/8 S		7.9 - 15.0	4.9 - 15.0				6.2	160
ENAG-A075	KAMB-007E	POE	24	17.9	13.2	5/8 S	3/8 S		8.2 - 15.0					6.2	160
C7AB-0100	KAJ*-0100	MIN	33.4	20.0	19.1	5/8 S	3/8 S		11.5 - 15.0	7.2 - 15.0	4.2 - 15.0			22	190
CBAM-0103	KAK1-0100	MIN	33.4	20.0	19.1	5/8 S	3/8 S			7.0 - 15.0	4.0 - 15.0			22	190
C8AJ-0100	KAR*-010E	POE	33.4	20.0	19.1	5/8 S	3/8 S		12.2 - 15.0	8.3 - 15.0	4.1 - 15.0			20	209
C3AM-0101	KAM*-0100	MIN	33.4	20.0	19.1	5/8 S	3/8 S		12.3 - 15.0	8.5 - 15.0	4.4 - 15.0			20	213
E8AJ-A100	KAR*-010E	POE	24	17.9	13.2	5/8 S	3/8 S		10.4 - 15.0	6.5 - 15.0	3.2 - 15.0			6.2	162
E3AM-A101	KAM*-0100	MIN	26.4	18.4	16.2	7/8 S	3/8 S		12.2 - 15.0	8.5 - 15.0	4.4 - 15.0			12	168
E8AJ-A100	KAR*-010E	POE	24	17.9	13.2	5/8 S	3/8 S		10.4 - 15.0	6.5 - 15.0	3.2 - 15.0			6.2	162
C8AJ-0100	KAR*-010E	POE	33.4	20.0	19.1	5/8 S	3/8 S		12.2 - 15.0	8.3 - 15.0	4.1 - 15.0			20	209
CNAG-0100	KAJB-010E	POE	33.4	20.0	19.1	7/8 S	1/2 S		11.5 - 15.0	8.7 - 15.0				20	190
ENAG-A100	KAJB-010E	POE	24	17.9	13.2	5/8 S	3/8 S		10.6 - 15.0	6.9 - 15.0				6.2	185
C7AB-0150	KALB-0150	MIN	33.4	20.0	19.1	7/8 S	1/2 S		15.3 - 20.0	9.7 - 15.0				20	270
CBAM-0153	KATB-0150	MIN	33.4	20.0	19.1	7/8 S	1/2 S		14.9 - 20.0	9.2 - 15.0				20	200
E3AH-A151	KAGB-0150	MIN	26.4	18.4	16.2	7/8 S	3/8 S		14.9 - 20.0	9.8 - 15.0				12	168
C3AH-0150	KAG*-0150	MIN	33.4	20.0	19.1	7/8 S	1/2 S		14.9 - 20.0	9.8 - 15.0	4.7 - 15.0			20	200
EPAK-A150	KALA-016E	POE	26.4	18.4	16.2	7/8 S	3/8 S		15.3 - 20.0	11.2 - 15.0				12	175
CPAK-0150	KALA-016E	POE	33.4	20.0	19.1	7/8 S	1/2 S		14.2 - 20.0	10.1 - 15.0				20	218
C7AB-0200	EAV*-0200	MIN	33.4	20.0	19.1	7/8 S	1/2 S		14.3 - 20.0	10.1 - 15.0	6.2 - 15.0			22	280
D8AJ-0200	KAKB-021E	POE	26.8	34.0	19.0	7/8 S	3/8 S		15.6 - 20.0	10.8 - 15.0				12	278
D8AM-0201	ERCA-021E	POE	34.0	26.8	19.0	7/8 S	3/8 S			13.3 - 15.0	5.9 - 15.0			12	354
C8AJ-0200	KAKB-021E	POE	33.4	20.0	19.1	7/8 S	1/2 S		16.2 - 20.0	11.4 - 15.0				20	296
C3AH-0204	KAKA-0200	MIN	33.4	20.0	19.1	7/8 S	1/2 S				5.4 - 15.0			20	300
C3AM-0202	ERC2-0200	MIN	33.4	20.0	19.1	7/8 S	1/2 S		15.4 - 20.0					20	270
C8AM-0202	ERCA-021E	POE	33.4	20.0	19.1	7/8 S	1/2 S			13.9 - 15.0	6.0 - 15.0			20	280
D8AJ-0200	KAKB-021E	POE	26.8	34.0	19.0	7/8 S	3/8 S		15.6 - 20.0	10.8 - 15.0				10	278
D8AM-0201	ERCA-021E	POE	27	34.0	19.0	7/8 S	3/8 S			13.3 - 15.0	5.9 - 15.0			10	354
C8AJ-0200	KAKB-021E	POE	33.4	20.0	19.1	7/8 S	1/2 S		16.2 - 20.0	11.4 - 15.0				22	296
C8AM-0202	ERCA-021E	POE	33.4	20.0	19.1	7/8 S	1/2 S			13.9 - 15.0	6.0 - 15.0			22	280
DNAG-0200	EAVB-021E	POE	26.8	34.0	19.0	7/8 S	3/8 S		20.7 - 30.0	11.6 - 15.0				12	337
CNAG-0200	EAVB-021E	POE	33.4	20.0	15.2	7/8 S	1/2 S		20.2 - 30.0	11.1 - 15.0				20	296
C7AB-0300	LAH1-0310	MIN	38.4	30.0	29.1	1-1/8 S	1/2 S		23.3 - 30.0	17.8 - 20.0	9.4 - 15.0			59	460
D8AJ-0300	ERFA-031E	POE	34.0	30.0	19.0	7/8 S	3/8 S			21.3 - 25.0	10.5 - 15.0			12	349
C3AH-0303	ERF2-0310	MIN	39.0	30.0	29.5	1-1/8 S	1/2 S		25.7 - 35.0	19.0 - 25.0	10.4 - 15.0	8.4 - 15.0		53	430
C8AJ-0300	ERFA-031E	POE	38.4	30.0	29.1	1-1/8 S	1/2 S			19.9 - 25.0	9.7 - 15.0			53	440
D8AJ-0300	ERFA-031E	POE	26.8	34.0	19.0	7/8 S	3/8 S			21.3 - 25.0	10.5 - 15.0			10	349
C8AJ-0300	ERFA-031E	POE	38.4	30.0	29.1	1-1/8 S	1/2 S			19.9 - 25.0	9.7 - 15.0			46	438
DTAH-0300	LAHB-031E	POE	34.1	26.2	18.9	1-1/8 S	3/8 S		26.6 - 35.0					12	380
CTAH-0300	LAHB-031E	POE	38.4	30.0	29.1	1-1/8 S	1/2 S		25.2 - 35.0					53	434
CPDK-0300	2DF3F16KE	POE	38.4	30.0	29.1	1-3/8 S	1/2 S			25.4 - 35.0	12.5 - 15.0	10.3 - 15.0		53	540
C8DJ-0500	2DC3R53KE	POE	38.4	30.0	29.1	1-3/8 S	5/8 S			32.2 - 50.0	15.4 - 20.0	11.5 - 15.0		53	555
C8DJ-0501	2DD3R63KE	POE	38.4	30.0	29.1	1-3/8 S	5/8 S			32.3 - 50.0	15.5 - 20.0	11.8 - 15.0		53	552
C8DJ-0500	2DC3R53KE	POE	38.4	30.0	29.1	1-3/8 S	5/8 S			32.3 - 50.0	15.4 - 20.0	11.5 - 15.0		53	555
C8DJ-0501	2DD3R63KE	POE	38.4	30.0	29.1	1-3/8 S	5/8 S			32.3 - 50.0	15.5 - 20.0			53	552
CPDK-0600	2DA3F23KE	POE	44.9	36.0	31.0	1-3/8 S	5/8 S			40.4 - 60.0	15.2 - 20.0			64	603
CPDK-0601	3DA3F28KE	POE	44.9	36.0	30.7	1-3/8 S	5/8 S			42.3 - 60.0	19.5 - 30.0			64	684
C8DJ-0750	2DA3R89KE	POE	44.9	36.0	31.0	1-3/8 S	5/8 S			45.7 - 70.0				64	657
C8DJ-0750	2DA3R89KE	POE	44.9	36.0	31.0	1-3/8 S	5/8 S			45.7 - 70.0				71	657
CPDK-0750	3DB3F33KE	POE	44.1	36.0	31.5	1-3/8 S	5/8 S			43.8 - 70.0	22.5 - 35.0	15.7 - 20.0		64	670
CPDK-0900	3DF3F40KE	POE	39.5	66.0	36.3	1-3/8 S	7/8 S			57.2 - 80.0	25.7 - 35.0			80	941
C8DJ-1000	3DB3R12ME	POE	39.5	66.0	36.3	1-3/8 S	7/8 S			63.3 - 90.0	29.6 - 45.0			80	941
C8DJ-1000	3DB3R12ME	POE	39.5	66.0	36.3	1-3/8 S	7/8 S			63.3 - 90.0	29.6 - 45.0			89	941
CPDK-1000	3DS3F46KE	POE	39.5	66.0	36.3	1-3/8 S	7/8 S			61.3 - 90.0	27.9 - 40.0			80	941

S = Sweat

Copelametic® air-cooled condensing units

Physical Data

LOW TEMP Model	Comp	Oil	Overall Dimensions (in)			Connecting Lines		Minimum Circuit Ampacity - Max Fuse Size					Pump Down Capacity (lbs)	Ship Weight (lbs)
			L	W	H	Suction	Liquid	115-1	230-1	230-3	460-3	575-3		
ENAG-A050	KANB-005E	POE	19.5	16.3	12.1	1/4 S	1/2 S	10.6 - 15.0					2.5	130
E8AL-A050	KANB-005E	POE	19.5	16.3	12.1	1/4 S	1/2 S		5.1 - 15.0				2.5	124
ENAG-A050	KANB-005E	POE	19.5	16.3	12.1	1/4 S	1/2 S	10.6 - 15.0					2.8	130
E8AL-A050	KANB-005E	POE	19.5	16.3	12.1	1/4 S	1/2 S		5.1 - 15.0				3.2	124
EJAL-A050	KAN*-00*E	POE	19.5	16.3	12.1	1/4 S	1/2 S	11.1 - 15.0	5.2 - 15.0	3.5 - 15.0			3.2	126
ENAG-A075	KAMB-007E	POE	24.0	17.9	13.2	3/8 S	5/8 S		8.2 - 15.0				6.2	160
E8AL-A075	KAM*-007E	POE	24.0	17.9	13.2	3/8 S	5/8 S	15.6 - 20.0		5.2 - 15.0			6.2	168
ENAG-A075	KAMB-007E	POE	24.0	17.9	13.2	3/8 S	5/8 S		8.2 - 15.0				5.4	190
E8AL-A075	KAM*-007E	POE	24.0	17.9	13.2	3/8 S	5/8 S	15.6 - 20.0		5.2 - 15.0			5.4	190
ENAG-A100	KAJ*-01*E	POE	24.0	17.9	13.2	3/8 S	5/8 S		10.6 - 15.0	6.9 - 15.0			6.2	185
CNAG-0100	KAJ*-01*E	POE	33.4	20.0	19.1	3/8 S	5/8 S		11.5 - 15.0	8.7 - 15.0			20	190
ENAG-A100	KAJ*-01*E	POE	24.0	17.9	13.2	3/8 S	5/8 S		10.6 - 15.0	6.9 - 15.0			5.4	185
CNAG-0100	KAJ*-01*E	POE	33.4	20.0	19.1	7/8 S	1/2 S		11.5 - 15.0	8.7 - 15.0			22	190
CLAL-0152	EADB-0200	MIN	33.4	20.0	19.1	1/2 S	7/8 S		12.3 - 15.0				20	265
C8AL-0151	EADA-020E	POE	33.4	20.0	19.1	3/8 S	7/8 S			10.3 - 15.0			20	280
EPAK-A150	KAL*-01*E	POE	26.0	18.3	16.1	3/8 S	7/8 S		15.3 - 20.0	11.2 - 15.0			10	175
EJAL-A150	KALA-016E	POE	26.4	20.0	16.2	3/8 S	7/8 S				5.9 - 15.0		10	169
CPAK-0150	KAL*-01*E	POE	33.4	20.0	19.1	3/8 S	7/8 S		14.2 - 20.0	10.1 - 15.0			22	218
CJAL-0152	KALA-016E	POE	33.4	20.0	19.1	3/8 S	7/8 S				5.5 - 15.0		22	295
CJAL-0153	EADB-021E	POE	33.4	20.0	19.1	3/8 S	7/8 S		14.3 - 20.0				22	283
C8AL-0151	EADA-020E	POE	33.4	20.0	19.1	3/8 S	7/8 S			10.3 - 15.0			22	280
DNAG-0200	EAV*-021E	POE	26.8	34.0	19.0	3/8 S	7/8 S		20.7 - 30.0	11.6 - 15.0			12	337
CNAG-0200	EAV*-021E	POE	33.4	20.0	15.2	1/2 S	7/8 S		20.2 - 30.0	11.1 - 15.0			20	296
C8AL-0200	EAVA-021E	POE	33.4	20.0	19.1	1/2 S	7/8 S				6.1 - 15.0		20	260
DNAG-0200	EAVB-021E	POE	26.8	34.0	19.0	3/8 S	7/8 S		20.7 - 30.0	11.6 - 15.0			10	337
CNAG-0200	EAV*-021E	POE	33.4	20.0	15.2	1/2 S	7/8 S		20.2 - 30.0	11.1 - 15.0			22	296
C8AL-0200	EAVA-021E	POE	33.4	20.0	19.1	1/2 S	7/8 S				6.1 - 15.0		22	260
DLAL-0301	LAH*-031*	MIN	34.1	26.2	18.9	3/8 S	1-1/8 S		26.6 - 35.0	19.2 - 20.0	9.7 - 15.0		12	380
CLAL-0300	LAH*-031*	MIN	39.0	30.0	29.5	1/2 S	1-1/8 S		25.2 - 35.0	17.8 - 20.0	8.9 - 15.0		53	465
DJAL-0300	LAHA-032E	POE	26.2	34.1	18.9	3/8 S	1-1/8 S				10.7 - 15.0		12	383
CJAL-0300	LAH*-032E	POE	38.4	30.0	29.1	1/2 S	1-1/8 S		25.3 - 35.0	20.3 - 25.0	9.9 - 15.0	7.0 - 15.0	59	460
CPDK-0300	2DF3F16KE	POE	38.4	30.0	29.1	1-3/8 S	1/2 S			25.4 - 35.0	12.5 - 15.0	10.3 - 15.0	59	540
CMDL-0400	2DL3F20K0	MIN	38.4	30.0	29.1	1-3/8 S	5/8 S		37.3 - 50.0				53	555
CJDL-0400	2DL3F20KE	POE	38.4	30.0	29.1	1-3/8 S	5/8 S			37.3 - 50.0	15.2 - 20.0	11.5 - 15	59	550
CPDK-0600	2DA3F23KE	POE	44.9	36.0	31.0	1-3/8 S	5/8 S			40.4 - 60.0	15.2 - 20.0		71	603
CPDK-0601	3DA3F28KE	POE	44.9	36.0	30.7	1-3/8 S	5/8 S			42.3 - 60.0	19.5 - 30.0		71	684
CPDK-0750	3DB3F33KE	POE	45.9	36.0	30.7	1-3/8 S	5/8 S			43.8 - 70.0	22.5 - 35.0	15.7 - 20.0	71	670
CPDK-0900	3DF3F40KE	POE	39.5	66.0	36.3	1-3/8 S	7/8 S			57.2 - 80.0	25.7 - 35.0		89	941
CPDK-1000	3DS3F46KE	POE	39.5	66.0	36.3	1-3/8 S	7/8 S			61.3 - 90.0	27.9 - 40.0		89	941
CPDK-0601	3DA*-060E	POE	44.0	36.0	31.5	1-3/8 S	5/8 S			42.3	19.5	15.1	55.4	630
CPDK-0750	3DB*-075E	POE	44.0	36.0	31.5	1-3/8 S	5/8 S			43.8	22.5	15.7	55.4	670
CPDK-0900	3DF*-090E	POE	39.0	66.0	36.0	1-3/8 S	7/8 S			57.2	25.7	24.4	69.4	935
CPDK-1000	3DS*-100E	POE	39.0	66.0	36.0	1-3/8 S	7/8 S			61.3	27.9	24.8	69.4	940

S = Sweat

Control Data

Unit	Horsepower	Voltage	BOM	Low Pressure Control	High/Low Pressure Control	Contactor	115 V Control
							Circuit Transformer
E	1/4 - 1/3	All	020	No	No	No	No
E	1/2 - 1	115-1, 208/230-1	020	Yes	No	No	No
E	1 1/2 - 2	115-1, 208/230-1	020		Yes	No	No
E	1/2 - 1	208/230-3	020		Yes	Yes	No
E	1/2 - 1	460-3	020		Yes	Yes	Yes
D	2 - 3	208/230-1	020		Yes	No	No
D	2 - 3	208/230-3	020		Yes	Yes	No
D	2 - 3	460-3	020		Yes	Yes	Yes
C	3/4 - 3	208/230-1	001		Yes	No	No
C	3/4 - 10	208/230-3	001		Yes	Yes	No
C	3 - 10	460-3, 575-3	001		Yes	Yes	Yes

All units come standard with a suction valve and receiver. All units are UL Listed.

W Line

Semi-hermetic water-cooled condensing units

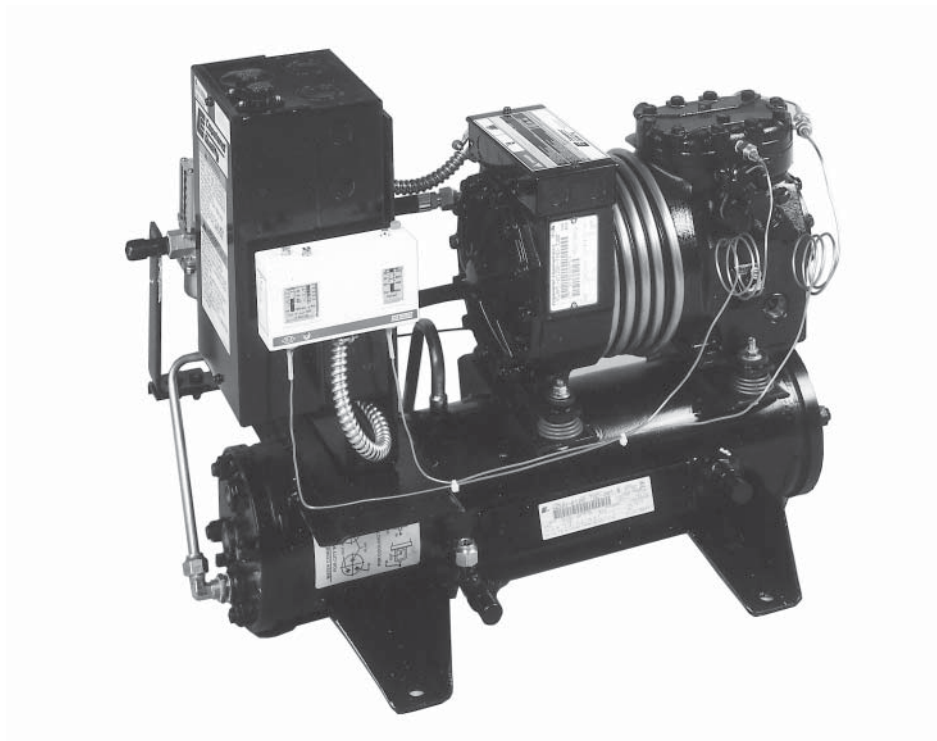

Product Information

Horsepower:	3/4 – 40
Temperature Applications:	Low/Medium/High
Refrigerants:	R-134a, R-404A, R-22
Installation Applications:	A variety of applications including walk-in boxes and industrial air dryers (Discus)

Nomenclature • Semi-Hermetic Condensing Units

Temperature Application		Compressor Motor Types		
Description	Code	Phase	Description	Code
High Temperature	H	1	Capacitor Run – Capacitor Start	C
Medium Temperature	M	1	Induction Run – Capacitor Start	I
Low Temperature	L	1	Induction Run – Split Phase	S
Extended Medium Temp.	F	1	Capacitor Run – Permanent Split Capacitor	P
Extra Low Temp.	E	3	Three Phase	T
High Temperature	B	3	Wye (star) Delta	E
R22/404A LT & R134a HT	G	3	6 Lead Part Winding or Across the Line – except 575V	F
R22 HT & R404A MT	J			
R404A LT & R134a HT	K			
Two Stage	U			
Two Stage	T			

Product Variations
Numbers will be assigned as follows:

- Number –100 is standard compressor used in Copeland® condensing units.
- Number –200 indicates a STANDARD compressor parts B/M and model no.
- Number –201 and larger will be assigned for all other variations of a given model.
- Number –800 indicates a standard replacement compressor and Component Parts B/M and model no. –240 volt control.
- Number –801 indicates a standard replacement compressor and component parts B/M and model no. –120 volt control.

Receiver Base	C
Flat Metal Base	E, D
Water Condenser Base	W
Transport Unit	T



Refrigerant	
R404A/507	J/4
R134a	T/2
R12	B/7
R22	3/M/L/C
Multiple	F
R22/407C	G
R22	9
R134a/404A/22	N
R134a/404A	P
R404A/22	8

Air Cooled Steel Base	A
Air Cooled Copevap Base	E
Water Cooled Steel Base	W
Custom Base	C
Discus	D

Comp. Motor Rating	
Nominal (HP)	Code
1/2	0050
3/4	0075
1	0100
1-1/2	0150
2	0200
3	0300
4	0400
5	0500
6	0600
7-1/2	0750
9	0900
10	1000
15	1500
20	2000
22	2200
25	2500
27	2700
30	3000
40	4000
50	5000
60	6000
70	7000
80	8000

Note: Left position may be a letter indicating a revision change

Compressor Motor Protection	
Type Protection	Code
External Inherent Protection-One Protector, (Line Break) Use with Contactor	A
Internal Inherent Protection-One Protector (Line Break) Use with Contactor	F
Internal Thermal Protectors-Electronic Sensors; and Control Module External Use with Contactor	S

Electrical Codes		
60 Hz.	50 Hz.	Code
115-1	100-1	A
230-1	-	B
208/230-3	200/220-3	C
460-3	-	D
575-3	-	E
-	230-1	G
-	380/420-3	M
208/230-1	200-1	V
-	220-3	W
-	220/240-1	Z

Note: When applicable, specific 50 Hz ratings (not necessarily identical to typical shown above) will be shown as alternate on 60 Hz rated models.

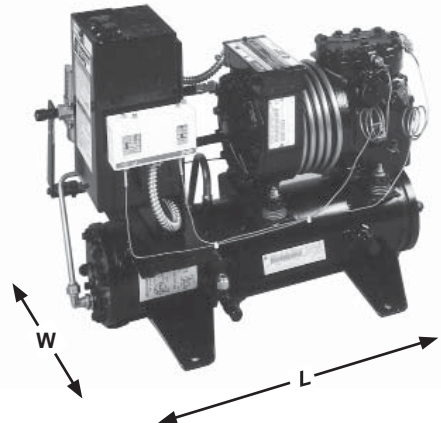

Semi-hermetic water-cooled condensing units

Features	Benefits
Copeland® Semi-hermetic Compressor Copeland Discus® Compressor with Unique 'Discus' Valve Design	Reliability
	High Energy Efficiency
Modular Components	Replacement Serviceability
Positive Displacement Oil Pump	Oil Lubrication Under All Operating Conditions Lower Service & Maintenance Cost
Low Re-expansion Volumes	Decreases Energy Costs Greater Capacity
Lower Operating Speeds	Reduces Operating Component Stress Low Sound Lower Maintenance Costs
Wide Range of Available Models from 3 HP to 40 HP For HCFC and HFC Refrigerants	Application Flexibility

Resources and Support

EmersonClimate.com

- Online Product Information and Technical Data
 - Application Engineering Bulletins
 - Instruction Sheets
 - Marketing Brochures
- Where to Buy

Application Engineering Bulletins

- AE5-1174 Water Flow Requirement and Water Pressure Drop for Copeland® Water-Cooled Condensing Units
- AE4-1135 Cooling Requirements for Copelametic® and Copeland Discus® Compressors

For more information, visit EmersonClimate.com and login to the Customer Portal to view Online Product Information

Semi-hermetic water-cooled condensing units

Capacity Data

HIGH/MED TEMP		Capacity (BTU/Hr) at 75° Inlet Water - Evaporator Temp (°F)						
Model	BOM	Refrig.	H.P.	-5	0	+5	+10	+15
W2WM-0075-CAV, TAC	001	22	3/4	3680	4260	4880	5550	6290
WJWM-0075-CAV, TAC	001	404A	3/4	3140	3670	4270	4940	5660
W2WH-0075-TAC	001	22	3/4		3450	3980	4570	5230
WTWH-0075-CAV	001	134a	3/4		3370	3910	4510	5160
W3WM-0100-CAV, TAC, TAD	001	22	1		5730	6700	7750	8890
WJWM-0100-TAC	001	404A	1	4890	5650	6410	7210	8090
W2WH-0100-CAV, TAC, TAD	001	22	1		5050	5800	6640	7570
WTWH-0100-CAV, TAC	001	134a	1		4140	4890	5700	6580
WJWM-0152-TAC	001	404A	1-1/2	5860	6470	7650	8640	9740
W2WH-0151-CAV, TAC, TAD	001	22	1-1/2		6390	7270	8310	9510
WTWH-0151-CAV, TAC	001	134a	1-1/2		5960	7040	8210	9470
W3WM-0201-CAV, TAC, TAD	001	22	2	7260	8690	10200	11700	13400
WJWM-0202-TAC	001	404A	2	8440	9750	11000	12300	13800
WJWM-0203-TAC, TAD	001	404A	2	10000	11600	13300	15100	17100
W2WH-0201-CAB, TAC, TAD	001	22	2		2960	5420	7890	10400
WTWH-A201-CAV, TAC, TAD	001	134a	2		8360	9880	11500	13300
WJWM-0300-TAC, TAD	001	404A	3	14800	17000	19400	22000	24800
W2WH-0300-CAB, TAC, TAD	001	22	3		14800	17100	19700	22400
WTDH-0301-TFC, TFD	001	134a	3		19600	22700	26100	29700
W3DD-0504-TFD	001	22	5		23100	27000	31300	35800
WJDM-0502-TFC, TFD	001	404A	5	22500	25800	29500	33600	38100
WTDH-0601-TFD	001	134a	6		24500	28300	32500	37100
W3DD-0752-TFC, TFD	001	22	7-1/2	33000	39400	46100	53100	60400
WJDM-0751-TFC, TFD	001	404A	7-1/2	41300	46600	52500	58900	66000
WTDH-0751-TFD	001	134a	7-1/2		34600	40100	46100	52500
W3DD-1003-TFC, TFD	001	22	10				75990	85930
WJDM-1001-TFC, TFD	001	404A	10	58100	65600	73700	82600	92200
W3DD-1502-TFC, TFD	001	22	15				102930	116170
W3DD-2002-TSD	001	22	20		84800	96500	109400	123700
W3DD-2502-TSC, TSD	001	22	25				142900	160200
W3DD-3002-TSC, TSD	001	22	30		129000	147100	167200	189200
W3DD-3502-TSD	001	22	35				209000	235300
W3DD-4001-TSD	001	22	40		199200	225300	253700	284500
LOW TEMP		Capacity (BTU/Hr) at 75° Inlet Water - Evaporator Temp (°F)						
Model	BOM	Refrig.	H.P.	-40	-35	-30	-25	-20
WJWL-0100-CAV, TAC, TAD	001	404A	1	2300	2800	3360	3980	4660
WJWL-0151-CAV, TAC, TAD	001	404A	2	3450	4200	5020	5920	6900
WJWL-A201-CAV, TAC, TAD	001	404A	2	4440	5460	6580	7810	9170
WJDL-0302-TFC, TFD	050	404A	3	9950	12100	14400	17000	19800
WJDL-0401-TFC, TFD	050	404A	4	12360	14900	17660	20700	24020
WJDL-0603-TFC, TFD	050	404A	6	18090	21350	24950	28920	33280
WJDL-0751-TFC, TFD	050	404A	8	21470	25470	29750	34390	39440
WJDL-0901-TFC, TFD	050	404A	9	26180	30920	36130	41850	48130
WJDL-1001-TFC, TFD	050	404A	10	29850	35220	41090	47500	54480
WJDL-1501-TSC, TSD	050	404A	15	41400	49300	57400	65800	74800
WJDL-2701-TSD	050	404A	27	59500	70700	83200	96900	121700

Performance data at 105° ambient – subcooling 5° F

Return gas temperature 65° F; Condenser water inlet temperature 85° F; Water temperature difference 10° F

Semi-hermetic water-cooled condensing units

Capacity Data

HIGH/MED TEMP		Capacity (BTU/Hr) at 75° Inlet Water - Evaporator Temp (°F)							
Model	BOM	Refrig.	H.P.	+20	+25	+30	+35	+40	+45
W2WM-0075-CAV, TAC	001	22	3/4	7110	8040				
WJWM-0075-CAV, TAC	001	404A	3/4	6450	7280				
W2WH-0075-TAC	001	22	3/4	5960	6750	7610	8550	9570	10700
WTWH-0075-CAV	001	134a	3/4	5860	6620	7440	8330	9270	10280
W3WM-0100-CAV, TAC, TAD	001	22	1	10100	11400				
WJWM-0100-TAC	001	404A	1	9090	10260				
W2WH-0100-CAV, TAC, TAD	001	22	1	8590	9700	10900	12200	13600	15000
WTWH-0100-CAV, TAC	001	134a	1	7540	8580	9730	11000	12400	13900
WJWM-0152-TAC	001	404A	1-1/2	11000	12400				
W2WH-0151-CAV, TAC, TAD	001	22	1-1/2	10900	12300	14000	15700	17600	19600
WTWH-0151-CAV, TAC	001	134a	1-1/2	10900	12400	14000	15800	17800	20000
W3WM-0201-CAV, TAC, TAD	001	22	2	15100	17000				
WJWM-0202-TAC	001	404A	2	15400	17400				
WJWM-0203-TAC, TAD	001	404A	2	19200	21600				
W2WH-0201-CAB, TAC, TAD	001	22	2	13000	15700	18600	21600	24800	28200
WTWH-A201-CAV, TAC, TAD	001	134a	2	15200	17300	19700	22200	25000	28000
WJWM-0300-TAC, TAD	001	404A	3	27800	31200				
W2WH-0300-CAB, TAC, TAD	001	22	3	25500	28800	32400	36200	40400	44900
WTDH-0301-TFC, TFD	001	134a	3	33700	38100	42900	48100	53800	60100
W3DD-0504-TFD	001	22	5	40800	46100	51900	58100	64900	72200
WJDM-0502-TFC, TFD	001	404A	5	43100	48510				
WTDH-0601-TFD	001	134a	6	42200	47700	53700	60400	67600	75400
W3DD-0752-TFC, TFD	001	22	7-1/2	68200	76500	85400	95000	105400	116500
WJDM-0751-TFC, TFD	001	404A	7-1/2	73700	82100				
WTDH-0751-TFD	001	134a	7-1/2	59600	67300	75800	85000	95200	106300
W3DD-1003-TFC, TFD	001	22	10	96610	108090	120430	133700	147950	163240
WJDM-1001-TFC, TFD	001	404A	10	102800	114200				
W3DD-1502-TFC, TFD	001	22	15	130360	145600	161970	179560	198450	218750
W3DD-2002-TSD	001	22	20	139400	156600	175600	196400	219200	244000
W3DD-2502-TSC, TSD	001	22	25	178800	198900	220700	244500	270400	298700
W3DD-3002-TSC, TSD	001	22	30	213200	239100	266800	296300	327600	360600
W3DD-3502-TSD	001	22	35	263500	293900	326800	362500	401400	443900
W3DD-4001-TSD	001	22	40	317900	353900	392600	434100	478600	526000
LOW TEMP		Capacity (BTU/Hr) at 75° Inlet Water - Evaporator Temp (°F)							
Model	BOM	Refrig.	H.P.	-15	-10	-5	0		
WJWL-0100-CAV, TAC, TAD	001	404A	1	5420	6250	7170	8180		
WJWL-0151-CAV, TAC, TAD	001	404A	2	7960	9130	10410	11800		
WJWL-A201-CAV, TAC, TAD	001	404A	2	10700	12300	14100	16100		
WJDL-0302-TFC, TFD	050	404A	3	22900	26300	30100	34200		
WJDL-0401-TFC, TFD	050	404A	4	27660	31640	36000	40760		
WJDL-0603-TFC, TFD	050	404A	6	38060	43300	49020	55260		
WJDL-0751-TFC, TFD	050	404A	8	44980	51090	57810	65240		
WJDL-0901-TFC, TFD	050	404A	9	55040	62620	70920	80010		
WJDL-1001-TFC, TFD	050	404A	10	62050	70250	79120	88680		
WJDL-1501-TSC, TSD	050	404A	15	84400	94800	106600	119600		
WJDL-2701-TSD	050	404A	27	127800	145000	163400	183000		

Performance data at 105° ambient – subcooling 5° F

Return gas temperature 65° F; Condenser water inlet temperature 85° F; Water temperature difference 10° F

Semi-hermetic water-cooled condensing units

Physical/Electrical Data

HIGH/MED TEMP Model	Comp	Refrig.	Overall Dimensions (In)			Connecting Lines		Base Mounting Centers		Condenser Water Connections	
			L	W	H	Suction	Liquid	Length	Width	In	Out
W2WM-0075-CAV, TAC	KWE2-0075	22	28.6	14.5	17.0	3/8 S	5/8 S	14	13	3/8 MPT	1/2 FPT
WJWM-0075-CAV, TAC	KWNB-007E	404A	28.6	14.5	17.0	3/8 S	5/8 S	14	12	3/8 MPT	1/2 FPT
W2WH-0075-TAC	KWN2-0075	22	28.6	14.5	17.0	3/8 S	5/8 S	14	13	3/8 MPT	1/2 FPT
WTWH-0075-CAV	KWMB-007E	134a	28.6	14.5	17.0	3/8 S	5/8 S	14	13	3/8 MPT	2 1/2 FPT
W3WM-0100-CAV, TAC, TAD	KWM2-0100	22	28.6	14.5	17.0	3/8 S	5/8 S	14	13	3/8 MPT	1/2 FPT
WJWM-0100-TAC	KWRA-010E	404A	28.6	14.5	17.0	3/8 S	5/8 S	14	12	3/8 MPT	1/2 FPT
W2WH-0100-CAV, TAC, TAD	KWR2-0100	22	28.6	14.5	17.0	3/8 S	5/8 S	14	13	3/8 MPT	1/2 FPT
WTWH-0100-CAV, TAC	KWJB-010E	134a	28.6	14.5	17.0	3/8 S	5/8 S	14	13	3/8 MPT	2 1/2 FPT
WJWM-0152-TAC	KWGA-010E	404A	34.8	14.5	17.0	3/8 S	7/8 S	18	13	3/8 MPT	1/2 FPT
W2WH-0151-CAV, TAC, TAD	KWGB-0150	22	34.8	14.5	17.0	3/8 S	7/8 S	18	13	3/8 MPT	1/2 FPT
WTWH-0151-CAV, TAC	KWLB-015E	134a	34.8	14.5	17.0	3/8 S	7/8 S	18	13	3/8 MPT	2 1/2 FPT
W3WM-0201-CAV, TAC, TAD	KWKB-0200	22	34.8	14.5	17.7	3/8 S	7/8 S	18	13	3/8 MPT	1/2 FPT
WJWM-0202-TAC	KWKA-020E	404A	34.8	14.5	17.7	3/8 S	7/8 S	18	13	3/8 MPT	1/2 NPT
WJWM-0203-TAC, TAD	ERCA-021E	404A	34.0	14.5	20.4	3/8 S	7/8 S	18	13	1/2 NPT	1/2 NPT
W2WH-0201-CAB, TAC, TAD	ERA2-0200	22	34.0	14.5	20.4	3/8 S	7/8 S	18	13	1/2 NPT	1/2 NPT
WTWH-A201-CAV, TAC, TAD	EAVB-021E	134a	35.6	14.5	20.4	3/8 S	7/8 S	18	13	1/2 NPT	1/2 NPT
WJWM-0300-TAC, TAD	ERFA-031E	404A	30.0	17.0	24.0	1/2 S	1-18 S	18	16	1-1/4 FPT	1-1/4 FPT
W2WH-0300-CAB, TAC, TAD	ERF2-0310	22	30.0	17.0	24.0	1/2 S	1-1/8 S	18	16	1-1/4 FPT	1-1/4 FPT
WTDH-0301-TFC, TFD	2DF3F16KE	134a	39.9	17.0	28.0	1/2 S	1-1/8 S	25	16	1-1/4 FPT	1-1/4 FPT
W3DD-0504-TFD	2DC3R53K0	22	39.9	17.0	28.0	1/2 S	1-3/8 S	25	16	1-1/4 FPT	1-1/4 FPT
WJDM-0502-TFC, TFD	2DC3R53KE	404A	40.0	17.0	28.0	1/2 S	1-3/8 S	25	16	1-1/4 FPT	1-1/4 FPT
WTDH-0601-TFD	2DA3F23KE	134a	39.9	17.0	28.0	1/2 S	1-3/8 S	25	16	1-1/4 FPT	1-14 FPT
W3DD-0752-TFC, TFD	2DA3R89KE	22	46.0	17.0	38.6	5/8 S	1-3/8 S	25	16	1-1/4 FPT	1-1/4 FPT
WJDM-0751-TFC, TFD	2DA3R89KE	404A	46.0	17.0	38.6	5/8 S	1-3/8 S	25	16	1-1/4 FPT	1-1/4 FPT
WTDH-0751-TFD	3DB3F33KE	134a	46.0	17.0	30.7	5/8 S	1-3/8 S	25	16	1-1/4 FPT	1-1/4 FPT
W3DD-1003-TFC, TFD	3DB3R12ME	22	52.0	17.0	30.6	7/8 S	1-3/8 S	38	16	1-1/4 FPT	1-1/4 FPT
WJDM-1001-TFC, TFD	3DB3R12ME	404A	52.0	17.0	30.6	7/8 S	1-3/8 S	38	16	1-1/4 FPT	1-1/4 FPT
W3DD-1502-TFC, TFD	3DS3R17ME	22	52.0	18.0	32.6	1-1/8 S	1-5/8 S	38	16	1-1/2 FPT	1-1/2 FPT
W3DD-2002-TSD	4DA3R18M0	22	64.0	20.2	34.3	1-1/8 S	1-5/8 S	38	16	2 FPT	2 FPT
W3DD-2502-TSC, TSD	4DH3R22M0	22	64.5	20.5	34.3	1-1/8 S	1-5/8 S	38	16	2 FPT	2 FPT
W3DD-3002-TSC, TSD	4DJ3R28M0	22	64.5	20.5	34.3	1-1/8 S	2-1/8 S	38	17	2 FPT	2 FPT
W3DD-3502-TSD	6DH3A3500	22	77.5	22.4	34.0	1-1/8 S	2-1/8 S	38	18	2-1/2 FPT	2-1/2 FPT
W3DD-4001-TSD	6DJ3A4000	22	89.5	21.4	36.0	1-5/8 S	2-1/8 S	38	18	2-1/2 FPT	2-1/2 FPT
LOW TEMP Model	Comp	Refrig.	Overall Dimensions (In)			Connecting Lines		Base Mounting Centers		Condenser Water Connections	
			L	W	H	Suction	Liquid	Length	Width	In	Out
WJWL-0100-CAV, TAC, TAD	KWJB-010E	404A	27	15	18	3/8 S	5/8 S	14	13	3/8 MPT	1/2 FPT
WJWL-0151-CAV, TAC, TAD	KWLB-015E	404A	35	15	17	3/8 S	7/8 S	18	13	3/8 MPT	1/2 FPT
WJWL-A201-CAV, TAC, TAD	EAVB-021E	404A	35	15	20	3/8 S	7/8 S	18	13	1/2 NPT	1/2 NPT
WJDL-0302-TFC, TFD	2DF3F16KE	404A	40	17	37	1/2 S	1-1/8 S	25	16	1-1/4 FPT	1-1/4 FPT
WJDL-0401-TFC, TFD	2DL3F20KE	404A	40	17	37	1/2 S	1-3/8 S	25	16	1-1/4 FPT	1-1/4 FPT
WJDL-0603-TFC, TFD	3DA3F-28KE	404A	46	17	39	5/8 S	1-3/8 S	25	16	1-1/4 FPT	1-1/4 FPT
WJDL-0751-TFC, TFD	3DB3F33KE	404A	46	17	39	5/8 S	1-3/8 S	25	16	1-1/4 FPT	1-1/4 FPT
WJDL-0901-TFC, TFD	3DF3F40KE	404A	52	17	39	7/8 S	1-3/8 S	38	16	1-1/4 FPT	1-1/4 FPT
WJDL-1001-TFC, TFD	3DS3F-46KE	404A	52	17	39	7/8 S	1-3/8 S	38	16	1-14 FPT	1-1/4 FPT
WJDL-1501-TSC, TSD	4DL3F-63KE	404A	52	19	38	1-1/8 S	1-5/8 S	38	16	1-1/2 FPT	1-1/2 FPT
WJDL-2701-TSD	6DL3F-93KE	404A	65	22	43	1-1/8 S	2-1/8 S	38	16	2 FPT	2 FPT

Performance data at 105° ambient – subcooling 5° F

Return gas temperature 65° F; Condenser water inlet temperature 85° F; Water temperature difference 10° F

Semi-hermetic water-cooled condensing units

Physical /Electrical Data

HIGH/MED TEMP Model	Comp	Refrig.	Minimum Circuit Ampacity - Max Fuse Size						Pump Down Capacity (lbs)	Ship Weight (lbs)
			230-1-60		230-3-60		460-3-60			
W2WM-0075-CAV, TAC	KWE2-0075	22			4.3	15			26	166
WJWM-0075-CAV, TAC	KWNB-007E	404A	6.8	15	3.8	15			23	174
W2WH-0075-TAC	KWN2-0075	22	7.6	15	4.4	15			26	166
WTWH-0075-CAV	KWMB-007E	134a	9	15	5.8	15			27	178
W3WM-0100-CAV, TAC, TAD	KWM2-0100	22	9.4	15	5.6	15	4	15	26	170
WJWM-0100-TAC	KWRA-010E	404A			5.4	15			23	209
W2WH-0100-CAV, TAC, TAD	KWR2-0100	22	9.3	15	5.4	15	3	15	14	170
WTWH-0100-CAV, TAC	KWJB-010E	134a	9	15	5.8	15			14	176
WJWM-0152-TAC	KWGA-010E	404A			6	15			28	178
W2WH-0151-CAV, TAC, TAD	KWGB-0150	22	12	20	6.9	15	3	15	28	225
WTWH-0151-CAV, TAC	KWLB-015E	134a	12	20	8.3	15			33	220
W3WM-0201-CAV, TAC, TAD	KWKB-0200	22	13.3	20	8.5	15	4	15	35	225
WJWM-0202-TAC	KWKB-021E	404A			8.5	15			31	225
WJWM-0203-TAC, TAD	ERCA-021E	404A			11	15	4	15	31	270
W2WH-0201-CAB, TAC, TAD	ERA2-0200	22	13	20	8.3	15	4	15	32	294
WTWH-A201-CAV, TAC, TAD	EAVB-021E	134a	19	30	9.9	15	5	15	36	311
WJWM-0300-TAC, TAD	ERFA-031E	404A			15.5	25	7	15	35	326
W2WH-0300-CAB, TAC, TAD	ERF2-0310	22	21.3	35	14.6	25	8	15	41	330
WTDH-0301-TFC, TFD	2DF3F16KE	134a			21	35	10	15	69	492
W3DD-0504-TFD	2DC3R53K0	22					13	20	70	514
WJDM-0502-TFC, TFD	2DC3R-53KE	404A			28	50	13	20	59	501
WTDH-0601-TFD	2DA3F23KE	134a					13	20	69	511
W3DD-0752-TFC, TFD	2DA3R89KE	22			40	70	18	30	129	564
WJDM-0751-TFC, TFD	2DA3R89KE	404A			40	70	18	30	112	590
WTDH-0751-TFD	3DB3F33KE	134a					20	35	130	634
W3DD-1003-TFC, TFD	3DB3R12ME	22			55	90	25	45	144	708
WJDM-1001-TFC, TFD	3DB3R12ME	404A			55	90	25	45	125	670
W3DD-1502-TFC, TFD	3DS3R17ME	22			80	125	36	60	202	935
W3DD-2002-TSD	4DA3R18ME	22					41	70	258	1160
W3DD-2502-TSC, TSD	4DH3R22ME	22			103	175	51	90	247	1233
W3DD-3002-TSC, TSD	4DJ3R28ME	22			118	200	59	100	248	1160
W3DD-3502-TSD	6DH3R35ME	22					67	110	293	1357
W3DD-4001-TSD	6DJ3A40ME	22					89	150	293	1522
LOW TEMP Model	Comp	Refrig.	Minimum Circuit Ampacity - Max Fuse Size						Pump Down Capacity (lbs)	Ship Weight (lbs)
			230-1-60		230-3-60		460-3-60			
WJWL-0100-CAV, TAC, TAD	KWJB-010E	404A	8.6	15	6	15	3	15	12	177
WJWL-0151-CAV, TAC, TAD	KWLB-015E	404A	12.4	20	8	15	4	15	28	218
WJWL-A201-CAV, TAC, TAD	EAVB-021E	404A	19	30	10	15	5	15	31	314
WJDL-0302-TFC, TFD	2DF3F16KE	404A			22	35	11	15	59	501
WJDL-0401-TFC, TFD	2DL3F20KE	404A			34	50	14	20	59	513
WJDL-0603-TFC, TFD	3DA3F28KE	404A			39	60	18	30	112	651
WJDL-0751-TFC, TFD	3DB3F33KE	404A			39	70	21	35	112	655
WJDL-0901-TFC, TFD	3DF3F40KE	404A			50	80	22	35	125	500
WJDL-1001-TFC, TFD	3DS3F46KE	404A			53	90	24	40	125	743
WJDL-1501-TSC, TSD	4DL3F63KE	404A			67	110	34	50	153	865
WJDL-2701-TSD	6DL3F93KE	404A					51	90	216	1195

Performance data at 105° ambient – subcooling 5° F

Return gas temperature 65° F; Condenser water inlet temperature 85° F; Water temperature difference 10° F

Appendix

Additional Information

- Copeland to Copeland Condensing Unit Cross Reference
- Tecumseh to Copeland Condensing Unit Cross Reference
- EK Filter Drier
- HMI Moisture Indicator
- HF/HFK Series Thermal Expansion Valve
- TXV Superheat Adjustment Chart
- Outdoor Hood Accessory Information
- Refrigerants and Lubricants Approved for Use in Copeland® Compressors

Copeland to Copeland condensing unit cross reference

Status	Product Number	Length (in)	Width (in)	Height (in)	Refrigerant	Application	Capacity	MCA / Fuse
Obsolete	MBFS-0017-SAA	13.8	11.1	9.7	12	HT	1090	4.2 - 15
Active	M2FH-0017-SAA	13.8	11.8	9.7	134a	HT	1150	4.3 - 15
Obsolete	MBFS-0020-SAA	13.8	11.1	9.7	12	HT	1260	5.5 - 15
Active	M2FH-0020-IAA	13.8	11.3	9.7	134a	HT	1330	5.2 - 15
Obsolete	MBFS-0024-SAA	13.8	11.8	9.7	12	HT	1730	6.3 - 15
Active	M2FH-0024-SAA	13.8	11.8	9.7	134a	HT	1810	6.3 - 15
Obsolete	MBFH-A026-IAA	13.8	11.8	9.7	12	HT	2770	6.9 - 15
Active	M2FH-0026-IAA	13.8	11.3	9.7	134a	HT	2080	6.9 - 15
Obsolete	MBFS-0033-IAA	13.8	11.8	9.7	12	HT	4080	9.7 - 15
Active	M2FH-A033-IAA	13.8	11.3	9.7	134a	HT	2620	9.9 - 15
Obsolete	MBFH-0049-IAA	16.2	13.1	11.8	12	HT	4890	12.5 - 20
Active	M2FH-0049-IAA	16.2	12.7	11.8	134a	HT	3600	12.5 - 20
Obsolete	MBFH-0050-IAA	17.9	13.1	11.8	12	HT	4030	13.8 - 20
Active	M2FH-0050-IAA	19	14.1	15	134a	HT	4230	13.6 - 20
Obsolete	FJAF-A050-IAA	16.2	13.2	11.9	404A	MT	4340	13.7 - 20
Active	M4FF-0050-IAA	16.1	13.7	11.7	404A	MT	4660	7.2 - 15
Obsolete	FJAF-A050-IAV	16.2	13.2	11.9	404A	MT	4340	7.8 - 15
Active	M4FF-0050-IAV	16.1	13.7	11.7	404A	MT	4660	7.2 - 15
Obsolete	FJAF-A056-IAA	17.5	14.3	12.1	404A	MT	5100	14.3 - 20
Active	M4FF-0056-IAA	17.4	14.4	11.8	404A	MT	5180	14.8 - 20
Obsolete	FJAF-A056-IAV	17.5	14.3	12.1	404A	MT	5630	8.1 - 15
Active	M4FF-0056-IAV	17.4	14.4	11.8	404A	MT	5350	7.6 - 15
Obsolete	FJAF-B078-CAA	24	16.9	13.1	404A	MT	6740	18.5 - 25
Active	M4FF-0075-CAA	24	17.1	13.1	404A	MT	6660	20.8 - 30
Obsolete	FJAF-B078-CAV	24	16.9	13.1	404A	MT	6740	8.8 - 15
Active	M4FF-0075-CAV	24	17.1	13.1	404A	MT	6660	9.7 - 15
Obsolete	FJAM-A106-CAV	24	18.3	16.2	404A	MT	8530	12.5 - 15
Active	FJAF-0106-CAV	24	18.3	16.1	404A	MT	8500	12.7 - 20
Obsolete	F3AD-B151-CFV	24	18.3	16.9	22	HT	11500	14.2 - 20
Active	FGAH-A151-CFV	24	18.3	16.9	22	HT	11300	14.2 - 20
Obsolete	F3AD-B151-TFC	24	18.3	16.9	22	HT	11300	10.4 - 15
Active	FGAH-A151-TFC	24	18.3	16.9	22	HT	11300	10.4 - 15
Obsolete	F3AD-B151-TFD	24	18.3	16.9	22	HT	11100	5.4 - 15
Active	FGAH-A151-TFD	24	18.3	16.9	22	HT	11300	5.4 - 15
Obsolete	F3AD-B201-CFV	25	34	19	22	HT	15400	19.2 - 30
Active	FGAH-A201-CFV	25	34	19	22	HT	15400	19.2 - 30
Obsolete	F3AD-B201-TFC	25	34	19	22	HT	15800	11.7 - 15
Active	FGAH-A201-TFC	25	34	19	22	HT	15400	11.7 - 15
Obsolete	F3AD-B201-TFD	25	34	19	22	HT	15800	6.1 - 15
Active	FGAH-A201-TFD	25	34	19	22	HT	15400	6.1 - 15
Obsolete	F3AD-B225-CFV	25.1	34.1	19	22	HT	17100	21.1 - 30
Active	FGAH-A225-CFV	25.1	34.1	19	22	HT	18100	21.1 - 30
Obsolete	F3AD-B225-TFC	25.1	34.1	19	22	HT	17100	13.3 - 15
Active	FGAH-A225-TFC	25.1	34.1	19	22	HT	18100	13.3 - 15
Obsolete	F3AD-B225-TFD	25.1	34.1	19	22	HT	17100	7.0 - 15
Active	FGAH-A225-TFD	25.1	34.1	19	22	HT	18100	7.0 - 15
Obsolete	F3AD-B301-CFV	25.2	34.1	19.1	22	HT	24600	28.9 - 40
Active	FGAH-A301-CFV	25.2	34.1	19.1	22	HT	24600	28.9 - 40
Obsolete	F3AD-B301-TFC	25.2	34.1	19.1	22	HT	24600	19.7 - 20
Active	FGAH-A301-TFC	25.2	34.1	19.1	22	HT	24600	19.7 - 20
Obsolete	F3AD-B301-TFD	25.2	34.1	19.1	22	HT	24600	10.2 - 15
Active	FGAH-A301-TFD	25.2	34.1	19.1	22	HT	24600	10.2 - 15
Obsolete	F3AD-B325-CFV	25.2	34.1	18.9	22	HT	26500	30.1 - 40
Active	FGAH-A325-CFV	25.2	34.1	18.9	22	HT	26400	30.1 - 40
Obsolete	F3AD-B325-TFC	25.2	34.1	18.9	22	HT	26500	22.2 - 25
Active	FGAH-A325-TFC	25.2	34.1	18.9	22	HT	26400	22.2 - 25
Obsolete	F3AD-B325-TFD	25.2	34.1	18.9	22	HT	26500	10.6 - 15
Active	FGAH-A325-TFD	25.2	34.1	18.9	22	HT	26400	10.6 - 15
Obsolete	F3AD-B401-TFC	28.2	44.1	26.9	22	HT	37600	26.1 - 40
Active	FGAH-A401-TFC	28.2	44.1	26.9	22	HT	37500	26.1 - 40
Obsolete	F3AD-B401-TFD	28.2	44.1	26.9	22	HT	37600	13.8 - 20
Active	FGAH-A401-TFD	28.2	44.1	26.9	22	HT	37500	13.8 - 20
Obsolete	F3AD-A501-CFV	28.6	44.1	26.9	22	HT	42700	46.4 - 70
Active	FGAH-A501-CFV	28.6	44.1	26.9	22	HT	43200	46.5 - 70

Capacity at +25° F Evap, 90° F Ambient for MT / HT Applications

Capacity at -10° F Evap, 90° F Ambient for LT Applications

Refrigerant change

Copeland to Copeland condensing unit cross reference

Status	Product Number	Length (in)	Width (in)	Height (in)	Refrigerant	Application	Capacity	MCA / Fuse
Obsolete	F3AD-A501-TFC	28.6	44.1	26.9	22	HT	42700	30.3 - 45
Active	FGAH-A501-TFC	28.6	44.1	26.9	22	HT	43200	30.4 - 45
Obsolete	F3AD-A501-TFD	28.6	44.1	26.9	22	HT	42700	14.4 - 20
Active	FGAH-A501-TFD	28.6	44.1	26.9	22	HT	43200	14.4 - 20
Obsolete	MBFL-0034-IAA	16	12.2	9.7	12	LT	1660	7.0 - 15
Active	M2FL-0040-IAA	16.5	12.4	9.7	134a	LT	1540	7.3 - 15
Obsolete	MBFL-0050-IAA	16.2	13.1	11.8	12	LT	2350	9.9 - 15
Active	FTAL-A050-IAA	16	13.1	11.9	134a	LT	2260	17.2 - 25
Obsolete	FJWM-C056-IAA	17.9	13.2	11.2	404A	MT	6000	12.6 - 20
Active	M4WF-C056-IAA	17.4	12.7	10.5	404A	MT	5890	13.1 - 20
Obsolete	FJWM-C056-IAV	17.9	13.2	11.2	404A	MT	6000	7.1 - 15
Active	M4WF-C056-IAV	17.4	12.7	10.5	404A	MT	5890	6.6 - 15
Obsolete	FJWM-C078-CAA	24	17.1	12.1	404A	MT	7930	16.5 - 25
Active	M4WF-C075-CAA	24	16.1	10.7	404A	MT	7560	18.8 - 30
Obsolete	FJWM-C078-CAV	24	17.1	12.1	404A	MT	7930	7.6 - 15
Active	M4WF-C075-CAV	24	16.1	10.7	404A	MT	7560	8.5 - 15
Obsolete	FJWM-C106-CAV	24	16.1	11.8	404A	MT	9100	9.6 - 15
Active	FJWF-C106-CAV	24.2	17.2	10.7	404A	MT	9470	11.3 - 20
Obsolete	FJWL-C075-IAV	24	16.1	11.6	404A	LT	3750	12.1 - 20
Active	M4WL-C075-IAV	24	16.4	10.7	404A	LT	4100	11.8 - 20
Obsolete	FTAH-A15Z-CFV	24	18.3	16.3	134a	HT	13100	23.8 - 40
Active	FFAS-A20Z-CFV	25.2	34	19	134a	HT	12200	21.8 - 35
Obsolete	FTAH-A15Z-TFC	24	18.3	16.3	134a	HT	13100	13.9 - 20
Active	FFAS-A20Z-TFC	25.2	34	19	134a	HT	12200	13.3 - 20
Obsolete	FTAH-A20Z-CFV	25.2	34	19	134a	HT	17000	28.1 - 45
Active	FFAS-A30Z-CFV	25.2	34	19	134a	HT	17700	28.7 - 45
Obsolete	FJAM-A20Z-CFV	25.2	34	19	404A	MT	18100	21.9 - 35
Active	FFAS-A20Z-CFV	25.2	34	19	404A	MT	17500	21.8 - 35
Obsolete	FJAM-A20Z-TFC	25.2	34	19	404A	MT	18100	13.4 - 20
Active	FFAS-A20Z-TFC	25.2	34	19	404A	MT	17500	13.3 - 20
Obsolete	FTAH-A25Z-CFV	25.2	34	19	134a	HT	19200	31.8 - 50
Active	FFAS-A30Z-CFV	25.2	34	19	134a	HT	17700	28.7 - 45
Obsolete	FTAH-A25Z-TFC	25.2	34	19	134a	HT	19200	19.7 - 30
Active	FFAS-A30Z-TFC	25.2	34	19	134a	HT	17700	17.9 - 25
Obsolete	FJAM-A25Z-CFV	25.2	34	19	404A	MT	23000	25.2 - 40
Active	FFAS-A25Z-CFV	25.2	34.1	19	404A	MT	23200	25.2 - 40
Obsolete	FJAM-A25Z-TFC	25.2	34	19	404A	MT	23000	15.3 - 20
Active	FFAS-A25Z-TFC	25.2	34.1	19	404A	MT	23200	15.3 - 20
Obsolete	FTAH-A30Z-CFV	25.2	34	19	134a	HT	23200	36.3 - 60
Active	FFAS-A40Z-CFV	28.2	44.1	26.1	134a	HT	24700	37.1 - 60
Obsolete	FTAH-A30Z-TFC	25.2	34	19	134a	HT	23200	22.4 - 35
Active	FFAS-A40Z-TFC	28.2	44.1	26.1	134a	HT	24700	23.2 - 35
Obsolete	FJAM-A30Z-CFV	25.2	34	19	404A	MT	26900	28.7 - 45
Active	FFAS-A30Z-CFV	25	34	19	404A	MT	26900	28.7 - 45
Obsolete	FJAM-A30Z-TFC	25.2	34	19	404A	MT	26900	17.9 - 25
Active	FFAS-A30Z-TFC	25	34	19	404A	MT	26900	17.9 - 25
Obsolete	FTAH-A35Z-CFV	25.2	34	19	134a	HT	27000	41.7 - 60
Active	FFAS-A50Z-CFV	28.1	44.1	26.8	134a	HT	29900	42.5 - 60
Obsolete	FTAH-A35Z-TFC	25.2	34	19	134a	HT	27000	30.4 - 45
Active	FFAS-A50Z-TFC	28.1	44.1	26.8	134a	HT	29900	31.2 - 45
Obsolete	FTAH-A35Z-TFD	25.2	34	19	134a	HT	27000	15.2 - 20
Active	FFAS-A50Z-TFD	28.1	44.1	26.8	134a	HT	29900	14.4 - 20
Obsolete	FJAM-A35Z-CFV	25.2	34	19	404A	MT	30500	32.3 - 50
Active	FFAS-A35Z-CFV	25.2	34	19	404A	MT	30400	32.3 - 50
Obsolete	FJAM-A35Z-TFC	25.2	34	19	404A	MT	30500	20.2 - 30
Active	FFAS-A35Z-TFC	25.2	34	19	404A	MT	30400	20.2 - 30
Obsolete	FTAH-A45Z-TFC	28.2	44.1	26.8	134a	HT	35000	31.7 - 50
Active	FFAS-A60Z-TFC	44.1	28.2	26.8	134a	MT	35000	31.7 - 50
Obsolete	FTAH-A45Z-TFD	28.2	44.1	26.8	134a	HT	35000	16.8 - 25
Active	FFAS-A60Z-TFD	44.1	28.2	26.8	134a	HT	35000	16.8 - 25
Obsolete	FJAM-A40Z-CFV	28.2	44.1	26.8	404A	MT	37800	37.1 - 60
Active	FFAS-A40Z-CFV	28.2	44.1	26.1	404A	MT	38100	37.1 - 60
Obsolete	FJAM-A40Z-TFC	28.2	44.1	26.8	404A	MT	37800	23.2 - 60
Active	FFAS-A40Z-TFC	28.2	44.1	26.1	404A	MT	38100	23.2 - 60

Capacity at +25° F Evap, 90° F Ambient for MT / HT Applications

Capacity at -10° F Evap, 90° F Ambient for LT Applications

Refrigerant change

Copeland to Copeland condensing unit cross reference

Status	Product Number	Length (in)	Width (in)	Height (in)	Refrigerant	Application	Capacity	MCA / Fuse
Obsolete	FTAH-A50Z-TFC	28.2	44.1	26.8	134a	HT	39200	39.4 - 60
Active	FFAS-A60Z-TFC	44.1	28.2	26.8	134a	MT	35000	31.7 - 50
Obsolete	FTAH-A50Z-TFD	28.2	44.1	26.8	134a	HT	39200	20.3 - 30
Active	FFAS-A60Z-TFD	44.1	28.2	26.8	134a	MT	35000	16.8 - 25
Obsolete	FJAM-A50Z-CFV	28.2	44.1	26.8	404A	MT	45600	42.5 - 60
Active	FFAS-A50Z-CFV	28.2	44.1	26.8	404A	MT	46100	42.5 - 60
Obsolete	FJAM-A50Z-TFC	28.2	44.1	26.8	404A	MT	45600	31.2 - 45
Active	FFAS-A50Z-TFC	28.2	44.1	26.8	404A	MT	46100	31.2 - 45
Obsolete	FJAM-A50Z-TFD	28.2	44.1	26.8	404A	MT	45600	14.4 - 20
Active	FFAS-A50Z-TFD	28.2	44.1	26.8	404A	MT	46100	14.4 - 20
Obsolete	FJAM-A60Z-TFC	28.2	44.1	26.8	404A	MT	52400	31.7 - 50
Active	FFAS-A60Z-TFC	44.1	28.2	26.8	404A	MT	53100	31.7 - 50
Obsolete	FJAM-A60Z-TFD	28.2	44.1	26.8	404A	MT	52400	16.8 - 25
Active	FFAS-A60Z-TFD	44.1	28.2	26.8	404A	MT	53100	16.8 - 25
Obsolete	M2EM-0048-IAA	16	15.1	11.8	134a	MT	3760	13.6 - 20
Active	M2EM-A048-IAA	16.5	15.1	11.8	134a	MT	3740	12.8 - 20
Obsolete	FJEF-B078-CAA	24	16.8	13.7	404A	MT	6740	18.5 - 25
Active	M4EF-0075-CAA	24	16.8	13.6	404A	MT	6620	20.8 - 30
Obsolete	FJEF-A075-IAV	24	16.1	13.7	404A	MT	7120	12.7 - 20
Active	M4EF-0080-IAV	24	16.8	13.6	404A	MT	7640	12.4 - 20
Obsolete	F3WD-C151-CFV-020	24	16.1	15	22	HT	13500	11.3 - 20
Active	FGWH-A151-CFV-020	24	16.7	14.3	22	HT	13500	11.3 - 20
Obsolete	F3WD-C151-TFC-020	24	16.1	14.2	22	HT	13500	7.5 - 15
Active	FGWH-A151-TFC-020	24	16.7	14.3	22	HT	13500	7.5 - 15
Obsolete	F3WD-C151-TFD-020	24	16.1	15.4	22	HT	13500	3.8 - 15
Active	FGWH-A151-TFD-020	24	16.7	15.4	22	HT	13500	3.8 - 15
Obsolete	F3WD-C201-CFV-020	24	16.1	15	22	HT	16900	16.9 - 30
Active	FGWH-A201-CFV-020	24	16.7	15	22	HT	16900	16.9 - 30
Obsolete	F3WD-C201-TFC-020	24	16.1	14.2	22	HT	16900	9.4 - 15
Active	FGWH-A201-TFC-020	24	16.7	14.3	22	HT	16900	9.4 - 15
Obsolete	F3WD-C201-TFD-020	24	16.1	15.4	22	HT	16900	4.6 - 15
Active	FGWH-A201-TFD-020	24	16.7	15.4	22	HT	16900	4.6 - 15
Obsolete	F3WD-C225-CFV-020	24	16.1	15	22	HT	19300	18.8 - 30
Active	FGWH-A225-CFV-020	24	16.7	15	22	HT	19300	18.8 - 30
Obsolete	F3WD-C225-TFC-020	24	16.1	14.6	22	HT	19300	11.0 - 15
Active	FGWH-A225-TFC-020	24	16.7	14.6	22	HT	19300	11.0 - 15
Obsolete	F3WD-C225-TFD-020	24	16.1	15.4	22	HT	19300	5.5 - 15
Active	FGWH-A225-TFD-020	24	16.7	15	22	HT	19300	5.5 - 15
Obsolete	F3WD-C301-CFV-020	26.2	21	15.4	22	HT	27300	23.1 - 40
Active	FGWH-A301-CFV-020	25	21	15.5	22	HT	27300	23.1 - 40
Obsolete	F3WD-C301-TFC-020	25	21	15.8	22	HT	27300	13.9 - 20
Active	FGWH-A301-TFC-020	25	21	15.8	22	HT	27300	13.9 - 20
Obsolete	F3WD-C301-TFD-020	25	21	15.8	22	HT	27300	7.0 - 15
Active	FGWH-A301-TFD-020	25	21	15.8	22	HT	27300	7.0 - 15
Obsolete	F3WD-C325-CFV-020	26.2	21	15.4	22	HT	29700	24.3 - 40
Active	FGWH-A325-CFV-020	25	21	15.5	22	HT	30200	24.3 - 40
Obsolete	F3WD-C325-TFC-020	25	21	16.1	22	HT	29700	16.4 - 25
Active	FGWH-A325-TFC-020	25	21	15.5	22	HT	30200	16.4 - 25
Obsolete	F3WD-C325-TFD-020	25	21	16.1	22	HT	29700	7.4 - 15
Active	FGWH-A325-TFD-020	25	21	15.5	22	HT	30200	7.4 - 15
Obsolete	F3WD-C401-CFV-020	26.8	21	21.1	22	HT	39400	36.3 - 60
Active	FGWH-A401-CFV-020	26.8	21	21.1	22	HT	39400	36.3 - 60
Obsolete	F3WD-C401-TFC-020	26.8	21	21.1	22	HT	39400	22.5 - 40
Active	FGWH-A401-TFC-020	26.8	21	21.1	22	HT	39400	22.5 - 40
Obsolete	F3WD-C401-TFD-020	26.8	21	21.1	22	HT	39400	11.4 - 20
Active	FGWH-A401-TFD-020	26.8	21	21.1	22	HT	39400	11.4 - 20
Obsolete	F3WD-C501-CFV-020	25.8	21.8	21.1	22	HT	45100	42.9 - 70
Active	FGWH-A501-CFV-020	25.8	21.8	21.1	22	HT	45100	42.9 - 70
Obsolete	F3WD-C501-TFC-020	25.8	21.8	21.1	22	HT	45100	26.8 - 45
Active	FGWH-A501-TFC-020	25.8	21.8	21.1	22	HT	45100	26.8 - 45
Obsolete	F3WD-C501-TFD-020	25.8	21.8	21.1	22	HT	45100	12.0 - 20
Active	FGWH-A501-TFD-020	25.8	21.8	21.1	22	HT	45100	12.0 - 20

Capacity at +25° F Evap, 90° F Ambient for MT / HT Applications Capacity at -10° F Evap, 90° F Ambient for LT Applications Refrigerant change

Tecumseh to Copeland condensing unit cross reference

Brand	Model Number	Length (in)	Width (in)	Height (in)	Refrig.	Application Evap Temp °F	Capacity Btu/Hr	MCA	Max Fuse
Tecumseh	AEA1360YXASS	16	11.5	9.9	134A	-10	610		15
Copeland	M2FL-0023-IAA-103	13.8	11.5	9.7	134A	-10	740	4.2	15
Tecumseh	AEA1360YXASS	16	11.5	9.9	134A	-10	610		15
Copeland	M2FL-0023-IAA-111	13.8	11.3	9.7	134A	-10	740	4.2	15
Tecumseh	AEA2380ZXASB	16	11.5	9.9	404A	-10	1030		15
Copeland	M4FL-0025-IAA-103	13.8	12	9.7	404A	-10	920	6.7	15
Copeland	M4FL-0025-IAA-072	14.5	12	11.4	404A	-10	920	6.7	15
Tecumseh	AEA2380ZXASB	16	11.5	9.9	404A	-10	1030		15
Copeland	M4FL-0025-IAA-103	13.8	12	9.7	404A	-10	920	6.7	15
Copeland	M4FL-0025-IAA-072	14.5	12	11.4	404A	-10	920	6.7	15
Tecumseh	AEA2410YXASB	16	11.5	9.9	134A	-10	1180		15
Copeland	M2FL-A025-IAA-103	13.8	11.8	9.7	134A	-10	1070	6.9	15
Tecumseh	AEA2410YXASB	16	11.5	9.9	134A	-10	1180		15
Copeland	M2FL-A025-IAA-103	13.8	11.8	9.7	134A	-10	1070	6.9	15
Tecumseh	AEA2411ZXASB	16	11.5	9.9	404A	-10	1340		15
Copeland	M4FL-0033-IAA-103	13.8	11.8	9.7	404A	-10	1390	7.7	15
Copeland	M4FL-0033-IAA-072	14.5	12	11.4	404A	-10	1390	7.7	15
Tecumseh	AEA2411ZXASS	16	11.5	9.9	404A	-10	1340		15
Copeland	M4FL-0033-IAA-111	13.9	11.7	9.6	404A	-10	1390	7.7	15
Copeland	M4FL-0033-IAA-072	14.5	12	11.4	404A	-10	1390	7.7	15
Tecumseh	AEA2413YXASB	16	11.5	9.9	134A	-10	1480		15
Copeland	M2FL-0040-IAA-103	16.7	12.6	9.7	134A	-10	1540	7.3	15
Tecumseh	AEA2413YXASB	16	11.5	9.9	134A	-10	1480		15
Copeland	M2FL-0040-IAA-103	16.7	12.8	9.7	134A	-10	1540	7.3	15
Tecumseh	AEA3414YXASB	16	11.5	9.9	134A	25	980		15
Copeland	M2HH-0017-SAA-102	16.5	6.6	10.8	134A	25	890	4.1	15
Copeland	M2FH-0017-IAA-103	13.8	11.9	9.7	134A	25	1150	4.3	15
Tecumseh	AEA3414YXASK	16	11.5	9.9	134A	25	980		15
Copeland	M2HH-0017-SAA-102	16.5	6.6	10.8	134A	25	890	4.1	15
Tecumseh	AEA3417YXASK	16	11.5	9.9	134A	25	1280		15
Copeland	M2FH-0020-IAA-111	13.6	11.1	9.7	134A	25	1330	5.2	15
Tecumseh	AEA3417YXASK	16	11.5	9.9	134A	25	1280		15
Copeland	M2FH-0020-IAA-111	13.6	11.8	9.7	134A	25	1330	5.2	15
Tecumseh	AEA3425YXASS	16	11.5	9.9	134A	25	1640		15
Copeland	M2FH-0024-SAA-111	13.8	11	9.7	134A	25	1810	6.3	15
Copeland	M4FH-0022-IAA-111	13.8	11.4	9.7	404A	25	1720	7.4	15
Copeland	MMFH-0022-IAA-103	13.8	11.5	9.7	22	25	1680	6.5	15
Tecumseh	AEA3425YXASS	16	11.5	9.9	134A	25	1640		15
Copeland	M2FH-0026-IAA-111	13.8	11.8	9.7	134A	25	2080	6.9	15
Copeland	M2FH-0026-IAA-072	14.5	12	11.4	134A	25	2080	6.9	15
Tecumseh	AEA4430YXASS	16	11.5	9.9	134A	25	2030		15
Copeland	M2FH-0026-IAA-111	13.8	11.8	9.7	134A	25	2080	6.9	15
Copeland	M2FH-0026-IAA-072	14.5	12	11.4	134A	25	2080	6.9	15
Tecumseh	AEA4430YXASB	16	11.5	9.9	134A	25	2030		15
Copeland	M2FH-0026-IAA-103	13.8	11.8	9.7	134A	25	2080	6.9	15
Copeland	M2FH-0026-IAA-072	14.5	12	11.4	134A	25	2080	6.9	15

Capacity at 90° F Ambient for LT / MT / HT Applications

Refrigerant change

Bold Models= Value Add Models With EK Filter Drier and HMI Moisture Indicator Sightglass

Tecumseh to Copeland condensing unit cross reference

Brand	Model Number	Length (in)	Width (in)	Height (in)	Refrig.	Application Evap Temp °F	Capacity Btu/Hr	MCA	Max Fuse
Tecumseh	AEA4440YXASK	16	11.5	9.9	134A	25	2610		15
Copeland	M2FH-A033-IAA-111	13.8	12	9.7	134A	25	2620	9.9	15
Tecumseh	AEA4440YXASB	16	11.5	9.9	134A	25	2610		15
Copeland	M2FH-A033-IAA-103	13.8	11.8	9.7	134A	25	2620	9.9	15
Copeland	M2FH-A033-IAA-272	14.5	12	11.4	134A	25	2620	9.9	15
Tecumseh	AEA4448YXASB	16	11.5	9.9	134A	25	3060		20
Copeland	M2FH-0040-IAA-212	16.3	12.5	9.7	134A	25	2870	10.2	15
Tecumseh	AEA4448YXASB	16	11.5	9.9	134A	25	3060		20
Copeland	M2FH-0040-IAA-212	16.3	12.5	9.7	134A	25	2870	10.2	15
Tecumseh	AEA9415EXASB	16	11.5	9.9	22	25	1880		15
Copeland	M2FH-0024-SAA-111	13.8	11	9.7	134A	25	1810	6.3	15
Copeland	MMFH-0022-IAA-103	13.8	11.5	9.7	22	25	1680	6.5	15
Copeland	MCFH-0027-IAA-103	13.8	11.4	9.7	22	25	2600	9.1	15
Tecumseh	AEA9415ZXASS	16	11.5	9.9	404A	25	1640		15
Copeland	M4FH-0022-IAA-111	13.8	11.4	9.7	404A	25	1720	7.4	15
Copeland	M4FH-0022-IAA-272	14.5	12.8	11.4	404A	25	1720	7.4	15
Tecumseh	AEA9415EXASB	16	11.5	9.9	22	25	1880		15
Copeland	M2FH-0024-SAA-102	13.8	11	9.7	134A	25	1810	6.3	15
Copeland	MMFH-0022-IAA-103	13.8	11.4	9.7	22	25	1680	6.5	15
Tecumseh	AEA9415ZXASS	16	11.5	9.9	404A	25	1640		15
Copeland	M4FH-0022-IAA-111	13.8	11.4	9.7	404A	25	1720	7.4	15
Copeland	M4FH-0022-IAA-272	14.46	12.8	11.36	404A	25	1720	7.4	15
Tecumseh	AEA9422EXASB	16	11.5	9.9	22	25	2680		15
Copeland	M2FH-A033-IAA-103	13.8	11.8	9.7	134A	25	2620	9.9	15
Copeland	MCFH-0027-IAA-103	13.8	11.4	9.7	22	25	2600	9.1	15
Copeland	MCFH-0027-IAA-272	14.2	12.3	11.8	22	25	2600	9.1	15
Tecumseh	AEA9422ZXASB	16	11.5	9.9	404A	25	2530		15
Copeland	M4FH-0025-IAA-103	13.8	11.4	9.7	404A	25	2430	10.7	15
Copeland	M4FH-0025-IAA-272	14.5	12	11.4	404A	25	2430	10.7	15
Tecumseh	AEA9422EXASS	16	11.5	9.9	22	25	2680		15
Copeland	MCFH-0027-IAA-111	13.8	11.2	9.7	22	25	2600	9.1	15
Copeland	MCFH-0027-IAA-272	14.1	12.3	11.2	22	25	2600	9.1	15
Tecumseh	AEA9422ZXASB	16	11.5	9.9	404A	25	2530		15
Copeland	M4FH-0025-IAA-103	13.8	11.8	9.7	404A	25	2430	10.7	15
Copeland	M4FH-0025-IAA-272	14.5	12	11.4	404A	25	2430	10.7	15

Capacity at 90° F Ambient for LT / MT / HT Applications

Bold Models= Value Add Models With EK Filter Drier and HMI Moisture Indicator Sightglass

 Refrigerant change

Emerson® EK filter drier

The EK filter drier is a best-in-class Emerson® product, recommended by Emerson Climate Technologies, Inc. for use with HFC refrigerants.

For more information about the EK filter drier see marketing brochure 2004FC-78 and Application Engineering Bulletin AE-1297

Application

- Premium compacted bead filter-drier with a finer 20 micron final outlet pad for maximum filtration
- Premium Universal replacement liquid line filter drier for CFC, HCFC and HFC refrigerants including R-12, R-134a, R-22, R-404A, R-407C, R-410A, R-500, R-502, R-507

Features

- Filtration first for more effective use of surface area of desiccant
- High moisture and acid removal
- Solid copper fittings
- Corrosion resistant epoxy powder paint finish
- Approved for POE Oils with Copeland® products
- Shock resistant steel shell construction

Specifications

- Desiccant blend - optimized for high water capacity and acid capacity
- Filtration: 20 microns
- Maximum working pressure: 680 psig
- UL/CUL file number: SA 3124

Dimensional Data

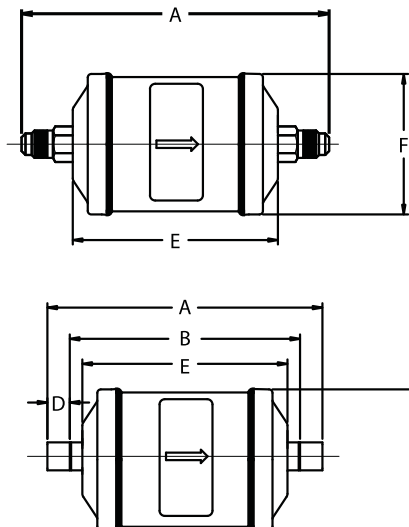

For more information see 2003FC-118 Wholesaler Catalog for Emerson® Valves, Controls and System Protectors



Ordering Information

PCN	Description	Dimensions (in)					Weight (lbs)
		A	B	D	E	F	
060009	EK 032	4.38	-	-	2.56	1.63	0.50
060012	EK 032S	3.88	3.13	0.38			
060011	EK 032FM	3.50	-	-			
060010	EK 032MF	3.50	-	-			
060013	EK 033	4.69	-	-	3.00	0.88	
060014	EK 033S	4.06	3.19	0.44			
047601	EK 052	4.81	-	-	3.02		
057013	EK 052MF	4.50	-	-			
063978	EK 0525S	3.57	0.32	2.64	3.00		
047602	EK 052S	4.44	3.69	0.38			
047603	EK 053	5.13	-	-	3.81	2.63	1.25
047604	EK 053S	4.50	3.63	0.44			
047605	EK 082	5.63	-	-	4.75		1.25
047606	EK 082S	5.25	4.50	0.38			
049551	EK 0825S	5.38	4.38	0.50	7.50	3.06	3.75
056906	EK 083MF	5.94	-	-			
047607	EK 083	5.94	-	-	7.63	3.69	4.75
047608	EK 083S	5.31	4.44	0.44			
047609	EK 084	6.19	-	-	13.06		7.50
047610	EK 084S	5.38	4.38	0.50			
047611	EK 162	6.56	-	-	7.50	3.06	3.75
047612	EK 162S	6.19	5.44	0.38			
056045	EK 1625S	5.94	5.31	0.31	7.63	3.69	4.75
047613	EK 163	6.88	-	-			
047614	EK 163S	6.25	5.44	0.44	7.50	3.06	3.75
047615	EK 164	7.06	-	-			
047616	EK 164S	6.31	5.31	0.50	7.63	3.69	4.75
047617	EK 165	7.50	-	-			
047618	EK 165S	6.56	5.31	0.63	7.50	3.06	3.75
047619	EK 167S	7.50	5.63	0.75			
048210	EK 303	9.63	-	-	7.63	3.69	4.75
048211	EK 303S	9.00	8.13	0.44			
048212	EK 304	9.88	-	-	7.50	3.06	3.75
048213	EK 304S	9.13	8.13	0.50			
048214	EK 305	10.31	-	-	7.63	3.69	4.75
048215	EK 305S	9.31	8.06	0.63			
048216	EK 306S	9.69	8.44	-	7.50	3.06	3.75
048217	EK 307S	9.88	8.38	0.75			
048218	EK 309S	10.25	8.44	0.94	7.63	3.69	4.75
048219	EK 413	9.75	-	-			
048220	EK 414	10.00	-	-	7.50	3.06	3.75
048221	EK 414S	9.25	8.25	0.50			
048222	EK 415	10.44	-	-	7.63	3.69	4.75
048223	EK 415S	9.44	8.19	0.63			
048224	EK 417S	10.00	8.50	0.75	13.06		7.50
048225	EK 419S	10.94	-	-			
048228	EK 757S	15.44	13.94	-	7.50		7.50
048229	EK 759S	15.75	13.88	0.94			

¹Does not include weld bead

Standard product offering

Nomenclature (example: EK-083S)

EK	08	3	S
Drier Series	Unit Size (in cu. in.)	Connection Size (in 1/8")	S=ODF connections (omit for SAE)

EK Filter Drier Capacity Data

Description	Connections Inlet/Outlet	Flow Capacity Tons @ 1 psi ΔP ^{1,4} (For kW, multiply tons by 3.5)						Water Capacity ² Drops of Water ³												
								R-12		R-134a		R-22		R-407C		R-410A		R-404A/507		R-502
		R-12	R-134a	R-22 R-410A	R-407C	R-404A R-507	75°F	125°F	75°F	125°F	75°F	125°F	75°F	125°F	75°F	125°F	75°F	125°F		
EK 03 2 FM	1/4 Fem/1/4 Male SAE	1.6	2.0	2.2	2.1	1.4	47	41	40	37	40	33	33	25	21	19	38	37	42	37
EK 03 2 MF	1/4 Male/1/4 Fem SAE	1.6	2.0	2.2	2.1	1.4														
EK 03 2	1/4 SAE	1.6	2.0	2.2	2.1	1.4														
EK 03 2 S	1/4 ODF	2.2	2.7	2.9	2.9	2.0														
EK 032 SV	1/4 ODF	2.2	2.7	2.9	2.9	2.0														
EK 03 3	3/8 SAE	2.5	3.0	3.3	3.2	2.2														
EK 03 3 S	3/8 ODF	2.5	3.0	3.3	3.2	2.2														
EK 05 2 FM	1/4 Fem/1/4 Male SAE	1.7	2.1	2.3	2.2	1.5	133	119	116	106	114	97	95	75	64	58	109	106	120	107
EK 05 2 MF	1/4 Male/1/4 Fem SAE	1.7	2.1	2.3	2.2	1.5														
EK 05 2	1/4 SAE	1.7	2.1	2.3	2.2	1.5														
EK 05 2 S	1/4 ODF	2.7	3.3	3.6	3.5	2.4														
EK 05 3 MF	3/8 Male/3/8 Fem SAE	2.9	3.5	3.8	3.7	2.5														
EK 05 3	3/8 SAE	2.9	3.5	3.8	3.7	2.5														
EK 05 3 S	3/8 ODF	3.6	4.4	4.8	4.7	3.2														
EK 08 2 FM	1/4 Fem/1/4 Male SAE	1.9	2.3	2.5	2.4	1.7	274	240	237	218	235	200	195	155	159	118	224	217	245	217
EK 08 2 MF	1/4 Male/1/4 Fem SAE	1.9	2.3	2.5	2.4	1.7														
EK 08 2	1/4 SAE	1.9	2.3	2.5	2.4	1.7														
EK 08 2 S	1/4 ODF	2.5	3.1	3.4	3.3	2.2														
EK 08 25 S	5/16 ODF	2.9	3.5	3.8	3.7	2.5														
EK 08 3 MF	3/8 Male/3/8 Fem SAE	3.3	4.0	4.3	4.3	2.9														
EK 08 3	3/8 SAE	3.3	4.0	4.3	4.3	2.9														
EK 08 3 S	3/8 ODF	3.7	4.5	4.9	4.8	3.3														
EK 08 4	1/2 SAE	5.5	6.7	7.3	7.1	4.9														
EK 08 4 S	1/2 ODF	5.8	7.1	7.7	7.5	5.1														
EK 16 2 MF	1/4 Male/1/4 Fem SAE	1.9	2.3	2.5	2.4	1.7	347	301	371	341	368	313	305	240	206	186	350	340	306	272
EK 16 2	1/4 SAE	1.9	2.3	2.5	2.4	1.7														
EK 16 2 S	1/4 ODF	2.5	3.1	3.4	3.3	2.2														
EK 16 25 S	5/16 ODF	2.5	3.1	3.4	3.3	2.2														
EK 16 3	3/8 SAE	3.2	3.9	4.2	4.1	2.8														
EK 16 3 S	3/8 ODF	3.6	4.4	4.8	4.7	3.2														
EK 16 4 S	1/2 ODF	7.0	8.5	9.2	9.0	6.2														
EK 16 5	5/8 SAE	8.0	9.7	10.5	10.3	7.0														
EK 16 5 S	5/8 ODF	8.3	10.1	10.9	10.7	7.3														
EK 16 7 S	7/8 ODF	12.7	15.5	16.8	16.5	11.2														
EK 30 3	3/8 SAE	3.5	4.3	4.7	4.6	3.1	601	526	664	611	657	561	548	434	515	355	627	608	536	477
EK 30 3 S	3/8 ODF	5.2	6.3	6.8	6.7	4.6														
EK 30 4	1/2 SAE	6.6	8.1	8.8	8.6	5.9														
EK 30 4 S	1/2 ODF	8.2	10.0	10.8	10.6	7.2														
EK 30 5	5/8 SAE	8.7	10.6	11.5	11.3	7.7														
EK 30 6 S	3/4 ODF	12.1	14.8	16.0	15.7	10.7														
EK 30 7 S	7/8 ODF	13.8	16.8	18.2	17.9	12.2														
EK 30 9 S	1 1/8 ODF	16.1	19.6	21.2	20.8	14.2														
EK 41 3	3/8 SAE	3.5	4.3	4.7	4.6	3.1	1104	971	938	854	919	785	765	607	715	465	876	850	991	884
EK 41 4	1/2 SAE	8.5	10.4	11.3	11.1	7.5														
EK 41 4 S	1/2 ODF	8.9	10.8	11.7	11.5	7.8														
EK 41 5	5/8 SAE	9.8	12.0	13.0	12.8	8.7														
EK 41 7 S	7/8 ODF	16.6	20.3	22.0	21.6	14.7														
EK 41 9 S	1 1/8 ODF	22.7	27.7	30.0	29.4	20.1														
EK 75 7 S	7/8 ODF	18.2	22.2	24.1	23.6	16.1	2368	2159	2159	2019	2159	1880	1810	1460	1460	1111	2019	2019	2229	2019
EK 75 9 S	1 1/8 ODF	26.8	32.7	35.4	34.8	23.7														

¹ All ratings in accordance with ARI Standard 710-04. 86°F liquid refrigerant temperature
5°F saturated vapor temperature
3.1 lbs./min./ton for R-134a
2.9 lbs./min./ton for R-22 and R-407C
4.0 lbs./min./ton for R-404A/507 and R-12
2.7 lbs./min./ton for R-410A

² Water Capacities are based on:
Equilibrium Point Dryness (EPD) of:
50 parts per million for R-134a, R404-A/507,
R-410A and R-407C
60 parts per million for R-22
15 parts per million for R-12

³ 20 drops of water = 1 gram = 1 cc

⁴ For 2 PSI ΔP , Multiply values by 1.4

Refrigerant Volume (oz.)

Unit Size	R-12		R-134a		R-22		R-407C		R-410A		R-404A/R-507		R-502	
	75°F	125°F	75°F	125°F	75°F	125°F	75°F	125°F	75°F	125°F	75°F	125°F	75°F	125°F
03	2.9	2.6	2.6	2.3	2.6	2.3	2.5	2.1	2.3	1.9	2.3	1.9	2.7	2.3
05	6.5	5.9	6.0	5.4	5.9	5.3	5.6	4.9	5.3	4.4	5.2	4.4	6.0	5.3
08	8.3	7.6	7.6	6.9	7.5	6.8	7.2	6.3	6.7	5.7	6.6	5.6	7.7	6.8
16	10.2	9.4	9.4	8.6	9.3	8.4	8.9	7.8	8.3	7.0	8.2	6.9	9.5	8.4
30	28.7	26.3	26.4	23.9	26.1	23.5	24.9	21.9	23.3	19.6	22.9	19.4	26.7	23.4
41	40.0	36.4	36.9	33.1	36.4	32.5	34.7	30.3	32.5	27.2	31.9	26.8	37.2	32.4
75	72.4	66.3	66.7	60.3	65.8	59.2	62.8	55.2	58.7	49.5	57.7	48.9	67.2	59.0

For more information see 2003FC-118 Wholesaler Catalog for Emerson® Valves, Controls and System Protectors

HMI-Hermetic Moisture Indicators

Application

- The HMI is designed to provide an accurate method of determining the moisture content of a system's refrigerant.
- The HMI has a unique high accuracy moisture indicator for CFC, HCFC, and HFC refrigerants.

Features

- Highest sensitivity moisture indicator available
- Hermetic, leak-free construction
- Single indicator for all common refrigerants
- Accurate color calibration at low ppm levels and higher temperatures
- Wide angle viewing/high visibility window for ease of monitoring
- All brass corrosion resistant body for fewer leaks
- Solid copper connections

Specifications

- Maximum working pressure: 680 psig
- UL/CUL file number: SA 9566

Dimensional Data (in)

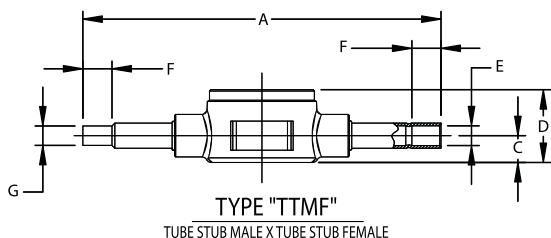
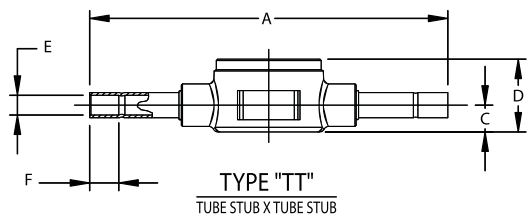
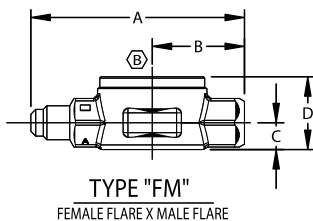
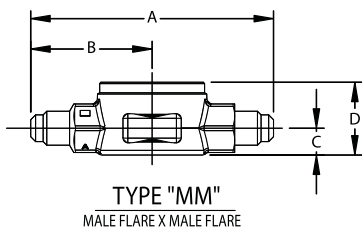

If it's not Blue,
It's not DRY!

Ordering Information

PCN	Description	Series	Connection Size
065391	HMI-1MM2	Male Flare x Male Flare	1/4
065392	HMI-1MM3		3/8
065393	HMI-1MM4		1/2
065394	HMI-1MM5		5/8
065395	HMI-1MM6		3/4
065405	HMI-1TT2		Sweat x Sweat (ODF)
065406	HMI-1TT3	3/8	
065407	HMI-1TT4	1/2	
065408	HMI-1TT5	5/8	
065409	HMI-1TT6	3/4	
065410	HMI-1TT7	7/8	
065411	HMI-1TT9	1 1/8	
065396	HMI-1FM2	Female Flare x Male Flare	1/4
065397	HMI-1FM3		3/8
065398	HMI-1FM4		1/2
065622	HMI-1TT2MF	Sweat x Sweat (ODM x ODF)	1/4
065814	HMI-1TT3MF		3/8
065979	HMI-1TT4MF		1/2
065980	HMI-1TT5MF		5/8

Standard product offering

Nomenclature (example: HMI 1TT4)

HMI	1	TT	4
Hermetic Moisture Indicator	Series	Connection Style TT = Sweat x Sweat	Connection Size (in 1/8")

Moisture Content Color Code (ppm H₂O)

Indication Liquid Temp.	Dry (Dark Blue)			Caution (Purple)			Wet (Salmon)		
	75°F	100°F	125°F	75°F	100°F	125°F	75°F	100°F	125°F
R-12	1.4	2.5	4	5	9	15	25	43	70
R-134A	20	35	60	35	55	85	130	160	190
R-22	25	35	50	40	65	90	145	205	290
R-407C	26	40	64	42	68	109	150	230	370
R-410A	30	55	75	50	85	120	165	290	420
R-404A/507	15	25	45	33	50	80	120	150	180

Dimensional Data (in)

Type Number	Connection Size	A	B	C	D	E	F Min	G
HMI - 1MM2	1/4 SAE	3.13	1.56	0.34	0.94			
HMI - 1MM3	3/8 SAE	3.38	1.69	0.34	0.94			
HMI - 1MM4	1/2 SAE	3.62	1.81	0.47	1.19			
HMI - 1MM5	5/8 SAE	3.88	1.94	0.47	1.19			
HMI - 1MM6	3/4 SAE	5.00	2.50	0.59	1.53			
HMI - 1FM2	1/4 SAE FM	2.75	1.19	0.34	0.94			
HMI - 1FM3	3/8 SAE FM	3.00	1.31	0.47	1.19			
HMI - 1FM4	1/2 SAE FM	3.22	1.41	0.47	1.19			
HMI - 1TT2	1/4 ODF	5.56		0.34	0.94	0.25	0.38	
HMI - 1TT3	3/8 ODF	5.61		0.34	0.94	0.38	0.40	
HMI - 1TT4	1/2 ODF	5.87		0.47	1.19	0.50	0.50	
HMI - 1TT5	5/8 ODF	5.87		0.61	1.19	0.63	0.63	
HMI - 1TT6	3/4 ODF	6.56		0.61	1.50	0.75	0.63	
HMI - 1TT7	7/8 ODF	6.31		0.61	1.50	0.88	0.75	
HMI - 1TT9	1 1/8 ODF	6.59		0.67	1.37	1.13	0.90	
HMI - 1TT2MF	1/4 ODM x 1/4 ODF	5.56		0.34	0.94	0.25	0.38	0.25
HMI - 1TT3MF	3/8 ODM x 3/8 ODF	5.61		0.34	0.94	0.38	0.38	0.38
HMI - 1TT4MF	1/2 ODM x 1/2 ODF	5.87		0.47	1.19	0.50	0.50	0.50
HMI - 1TT5MF	5/8 ODM x 5/8 ODF	5.87		0.61	1.19	0.63	0.50	0.62

For more information see 2003FC-118 Wholesaler Catalog for Emerson® Valves, Controls and System Protectors

Emerson® HF/HFK series thermal expansion valve

The HF series is a balanced ported valve designed for refrigeration, air conditioning and heat pump applications.

Features

- Stainless steel replaceable power element eliminates corrosion and prevents valve failure
- Two body sizes provide capacities from 1/4 to 20 ton

Standard Body – HF & HFK

- The HF is offered several ways:
 - *Pre-packaged HFK service kits* – Include a mix of bodies and power elements with a complete set of cages to serve the most applications with a minimum of parts
 - *Individual components* – Bodies, cages, & power elements may be ordered separately
 - *Finished valves* – Assembled valves ready for immediate installation
- Bi-Flow capability up to 5-1/2 tons R-22 allows one valve to control the superheat in both cooling and heating modes

Extended Body – HF

- Capacity range from 8 to 20 tons (R-22)
- Finished valve only



NOTE: If the HF body is stamped HFK, the cage is replaceable.

Options

- ODF or SAE connections
- Straight-through or angle flow configurations
- Removable inlet strainer (ODF only)
- Internal or external equalizer

Specifications

- Maximum working pressure: 450 psig

Nomenclature example: HFESC 2 HC 5 FT 3/8 x 1/2 ODF S/T

HF	N	E	S	C	B	2	H	C	5 FT	3/8 x 1/2	ODF	S/T
Valve Series Balanced Port Design	Superheat Adjustment N = Non-Adjustable Omit for Adjustable	Equalizer E=External (Omit for Internal)	Connection Type S = Solder (Omit for SAE Flare)	Removable Inlet Strainer (optional) C = Inlet Strainer (ODF only)	Bleed Hole (optional) (Omit for no bleed hole)	Capacity Nominal Rating in Tons (See nominal capacity table below)	Refrigerant Code +F = R-12 • H = R-22 +M = R-134a • N = R-407C * P = R-507 * R = R-502 * S = R-404A	Charge Code C = medium temp CA = heat pump W(MOP) = press. limiting Z = low temp AA = wide range	Capillary Tube Length 5 FT (std)	Inlet x Outlet Connection Sizes 1/4 x 3/8 3/8 x 1/2	Connection Type SAE = flare ODF = solder	Configuration ANG = 90° angle S/T = straight-thru

+ = R-12 and R-134a are interchangeable refrigerant charges
 * = R-507, R-502 and R-404A are interchangeable refrigerant charges
 • = R-22 and R-407C are interchangeable refrigerant charges

HF Series-Nominal* Capacity Tables in Tons (kW)

Standard Body HF

R-12	R-134a	R-22/R-407C	R-502/R-404A/R-507
1/8 (0.4)	1/4 (0.9)	1/4 (0.9)	1/8 (0.4)
1/4 (0.9)	1/2 (1.8)	1/2 (1.8)	1/4 (0.9)
1/2 (1.8)	3/4 (2.7)	1 (3.5)	1/2 (1.8)
1 (3.5)	1 (3.5)	1 1/2 (5.3)	1 (3.5)
1 1/4 (4.4)	1 1/2 (5.3)	2 (7.0)	1 1/4 (4.4)
1 1/2 (5.3)	1 3/4 (6.2)	2 1/2 (8.8)	1 1/2 (5.3)
2 (7.0)	2 1/2 (8.8)	3 (11.0)	2 (7.0)
3 1/2 (12.0)	4 (14.0)	5 1/2 (20.0)	3 1/2 (12.0)

Extended Body HF

R-12	R-134a	R-22/R-407C	R-502/R-404A/R-507
5 (17.0)	6 (21.0)	8 (28.0)	5 (17.0)
6 (21.0)	7 1/2 (27.0)	10 (35.0)	7 (27.0)
9 (32.0)	11 (39.0)	15 (53.0)	10 (35.0)
12 (42.0)	14 (50.0)	20 (70.0)	13 (46.0)

All capacities shown are at 100°F condensing, 40°F evaporator temperature.
 *See Extended Capacity Tables for ratings at a wide range of conditions per ARI standard 750.

For more information see 2003FC-118 Wholesaler Catalog for Emerson® Valves, Controls and System Protectors

Ordering Information

Use the following tables to order individual components.

HFK Body Selection Table

PCN	Description	Type	Connections (Inlet x Outlet)
064881	KT-20298-1	HFK	1/4 x 1/2 SAE Ang Inlet
064882	KT-20298-2	HFK	3/8 x 1/2 SAE Ang Inlet
064883	KT-20298-3	HFKE	1/4 x 1/2 SAE Ang Inlet
064884	KT-20298-4	HFKE	3/8 x 1/2 SAE Ang Inlet
064885	KT-20298-5	HFKSC	3/8 x 1/2 ODF Ang Inlet w/ Strainer
064886	KT-20298-6	HFKESC	3/8 x 1/2 ODF Ang Inlet w/ Strainer
064887	KT-20298-7	HFKS	3/8 x 1/2 ODF S/T
064888	KT-20298-8	HFKS	3/8 x 5/8 ODF S/T
064889	KT-20298-9	HFKS	1/2 x 5/8 ODF S/T
064890	KT-20298-10	HFKS	1/2 x 7/8 ODF S/T
064891	KT-20298-11	HFKES	3/8 x 1/2 ODF S/T
064892	KT-20298-12	HFKES	3/8 x 5/8 ODF S/T
064895	KT-20298-13	HFKES	1/2 x 5/8 ODF S/T
064896	KT-20298-14	HFKES	1/2 x 7/8 ODF S/T

HF & HFK Power Element Table

PCN	Description	System Refrigerant(s)	Application
053769	X26300-FW15-1	R-134a/R-12	Low Temp MOP
054798	X26300-FW35-1	R-134a/R-12	Low Temp MOP
063869	X26300-FW55-1	R-134a/R-12	Low Temp MOP
053766	X26300-FZ-1	R-134a/R-12	Low Temp
053763	X26300-FC-1	R-134a/R-12	Medium Temp
058074	X26300-MC-1	R-134a	Medium Temp
053767	X26300-HZ-1	R-22/R-407C	Low Temp
057834	X26300-HCA-1	R-22/R-407C	Heat Pump
057764	X26300-HW100-1	R-22/R-407C	AC MOP
053764	X26300-HC-1	R-22/R-407C	A/C Med. Temp
058085	X26300-SW45-1	R-404/ R-507/ R-502	Low Temp MOP
058082	X26300-SZ-1	R-404/ R-507/ R-502	Low Temp
058083	X26300-SC-1	R-404/ R-507/ R-502	Medium Temp

HFK Cage Nominal* Capacity Table

PCN	Description ¹	Cage Code	R-12	R-22	R-134a	R-404	R-507	R-502	R-407C
064868	KT-20299-0	0	1/8	1/4	1/4	1/8	1/8	1/8	1/4
064869	KT-20299-1	1	1/4	1/2	1/2	1/4	1/4	1/4	1/2
064870	KT-20299-2	2	1/2	1	3/4	1/2	1/2	1/2	1
064871	KT-20299-3	3	1	1 1/2	1	1	1	1	1 1/2
064872	KT-20299-4	4	1 1/4	2	1 1/2	1 1/4	1 1/4	1 1/4	2
064873	KT-20299-5	5	1 1/2	2 1/2	1 3/4	1 1/2	1 1/2	1 1/2	2 1/2
064874	KT-20299-6	6	2	3	2 1/2	2	2	2	3
064875	KT-20299-7	7	3 1/2	5 1/2	4	3 1/2	3 1/2	3 1/2	5 1/2

¹ Cage Kit includes Cage, Insertion Tool and ID Clips.

*All capacities shown are at 100°F condensing, 40°F evaporator temperature.

See Extended Capacity Tables for ratings at a wide range of conditions per ARI standard 750.

Cage Kit (PCN 064879)

Item	Qty
Size 0 Cage (1/4 ton R-22)	2
Size 1 Cage (1/2 ton R-22)	2
Size 2 Cage (1 ton R-22)	2
Size 3 Cage (1 1/2 ton R-22)	2
Size 4 Cage (2 ton R-22)	2
Size 5 Cage (2 1/2 ton R-22)	2
Size 6 Cage (3 ton R-22)	2
Size 7 Cage (5 1/2 ton R-22)	2
Insertion Tool	1
Oil Bottle	1
Cage ID Tags	16

Replacement Parts – SAE Inlet

PCN	Part Number	Description
027385	X-11176-1	Filter Screen
058707	27676-1	Seal Cap

Replacement Parts- HFSC & HFESC Only

PCN	Kit Number	Description
057686	KT-20264	Includes seal cap, gasket o-ring, screen, spring

HFK Accessories

PCN	Description
064880	Service Box
064897	Cage Box (Empty)
064898	Insertion Tool
064899	Oil Bottle
065203	Cage Gasket Kit (12 sets)

TXV SUPERHEAT ADJUSTMENT

Valve Family	Total Turns	Degrees of SH Per Turn					
		R-22		R-134a	R-404A/507		R410A
		+20 F	-20 F	+20 F	+20F	-20F	+40F
A	8	3.0	5.0	4.5	2.0	4.0	2.0
C	12	–	–	–	–	–	4.0
HF	10	2.2	4.2	3.8	1.8	3.2	N/A
TF	10	3.0	5.0	4.5	2.0	4.0	2.0
TRAE	10	2.2	4.2	3.8	1.8	3.2	N/A
TCLE	32	0.8	1.5	1.0	0.5	1.0	N/A

Turn adjustment clockwise to increase superheat, counterclockwise to decrease superheat. To return to approximate original factory setting, turn adjustment stem counterclockwise until the spring is completely unloaded (reaches stop or starts to ratchet). Then, turn it back in one half of the Total Turns shown on the chart.

Standard Product Offering

For more information see 2003FC-118 Wholesaler Catalog for Emerson® Valves, Controls and System Protectors

Flex-Line hoods for SystemPro® condensing units

- Four outdoor enclosures to cover all ½ to 6 HP SystemPro® units
- Assembly time reduced 50%
- UL listed
- Elevated rails
- Sliding panels for ease of service
- Ample space for additional features

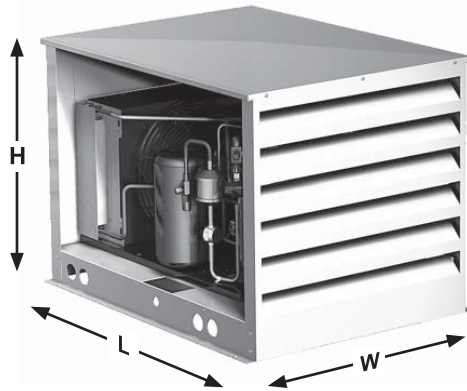

Hood Selection

Copeland® Model	Dimensions (in.)			Hood	Flex-Line Hood
	L	W	H		
SystemPro® Air-Cooled					
M2FH-0017	13.8	11.8	9.7	005-0882-00 / -09	505-7066-00
M2FH-0026	13.8	11.8	9.7	005-0882-00 / -09	505-7066-00
M2FH-0033	13.8	11.8	9.7	005-0882-00 / -09	505-7066-00
M2FH-0056	17.4	14.4	11.8	005-0882-00 / -09	505-7066-00
M4FH-0025	13.8	11.8	9.7	005-0882-00 / -09	505-7066-00
M4FH-A036	16.1	12.7	11.8	005-0882-00 / -09	505-7066-00
M2FL-0020	13.8	11.1	9.7	005-0882-00 / -09	505-7066-00
M2FL-A025	13.8	11.8	9.7	005-0882-00 / -09	505-7066-00
M2FL-B033	16.2	12.4	9.7	005-0882-00 / -09	505-7066-00
M4FL-0040	16.2	13.1	11.8	005-0882-00 / -09	505-7066-00
M4FL-0051	17.4	13.1	11.8	005-0882-00 / -09	505-7066-00
M4FL-0067	18.1	14.4	11.8	005-0882-00 / -09	505-7066-00
MCFH-0027	13.8	11.8	9.7	005-0882-00 / -09	505-7066-00
MCFH-0036	16	12.9	11.8	005-0882-00 / -09	505-7066-00
MCFH-0056	17.5	14.3	11.8	005-0882-00 / -09	505-7066-00
M4FF-0056	17.5	14.3	12.1	005-0882-00 / -09	505-7066-00
M4FF-0080	24.0	16.9	13.1	005-0882-00 / -09	505-7066-01
FJAL-A101	24.0	16.9	13.1	005-0882-00 / -09	505-7066-01
FJAL-B200	24.0	19.5	16.3	005-0882-02 / -10	505-7066-01
FJAL-B301	25.2	34.1	19.0	005-0882-01 / -11	505-7066-02
FJAL-A390	25.2	34.1	19.0	005-0882-01 / -11	505-7066-02
FJAF-0106	24.0	18.3	16.2	005-0882-00 / -09	505-7066-01
FJAM-A200	25.2	34.1	18.9	005-0882-01 / -11	505-7066-02
FJAM-B400	28.2	44.1	26.9	005-0882-04	505-7066-03
FTAH-B074	17.4	14.4	11.8	005-0882-00 / -09	505-7066-00
FTAH-A101	24.0	16.8	15.9	005-0882-00 / -09	505-7066-01
FTAH-A150	24.0	18.4	16.3	005-0882-02 / -10	505-7066-01
FTAH-A201	25.2	34.0	18.9	005-0882-01 / -11	505-7066-02
FTAL-A050	16.0	13.3	11.9	005-0882-00 / -09	505-7066-00
FGAH-A151	24.1	18.3	16.9	005-0882-02 / -10	505-7066-01
FGAH-A201	25.0	34.0	19.0	005-0882-01 / -11	505-7066-02
FGAH-A301	25.0	34.0	19.0	005-0882-01 / -11	505-7066-02
FGAH-A401	28.6	44.1	26.9	005-0882-04	505-7066-03
FGAH-A501	28.6	44.1	26.9	005-0882-04	505-7066-03
F3AH-A078	24.0	16.9	13.1	005-0882-00 / -09	505-7066-01
F3AH-A100	24.0	16.9	13.1	005-0882-00 / -09	505-7066-01

Hood Specification Data

Emerson Part #	Mfg. Part #	External Dimensions (in.)			Internal Dimensions (in.)			Unit Size*
		L	W	H	L	W	H	
505-7066-00	N/A	24.3	20.2	18.7	22.5	18.4	15.0	1/2 Hp to 3/4 Hp
505-7066-01	N/A	30.3	23.5	22.7	28.5	22.2	19	3/4 Hp to 2 Hp
505-7066-02	N/A	32.3	38.3	22.7	30.6	37.1	24.0	2 Hp to 3 Hp
505-7066-03	N/A	35.3	48	34.7	33.6	46.2	30.7	4 Hp to 6 Hp
005-0882-03	CHO-13	35.5	24.0	25.0	34.5	24.0	21.0	
005-0882-05	CHO-16	46.5	38.0	38.0	45.5	38.0	33.0	
005-0882-06	CHO-17	42.5	74.0	48.5	41.5	74.0	40.5	

UL Listed for outdoor use * Specific model to hood cross reference should be used.

Flex-Line hoods for semi-hermetic condensing units

Hood Selection

Copeland® Model	Dimensions (in.)			Hood	Flex-Line Hood
	L	W	H		
Copelametic®					
E3AH-A050	19.5	14.8	12.0	005-0882-00 / -09	505-7066-00
E3AM-A075	24.0	17.9	13.6	005-0882-00 / -09	505-7066-01
E8AJ-A075	24.0	17.9	13.6	005-0882-00 / -09	505-7066-01
E8AL-A050	19.5	16.3	12.0	005-0882-00 / -09	505-7066-00
E8AL-A075	24.0	17.9	13.3	005-0882-00 / -09	505-7066-01
E8AM-A050	19.5	14.8	12.0	005-0882-00 / -09	505-7066-00
ENAG-A050	19.5	16.3	12.0	005-0882-00 / -09	505-7066-00
ENAG-A075	24.0	17.9	12.0	005-0882-00 / -09	505-7066-01
CBAM-0103	33.5	20.0	19.0	005-0882-03	N/A
C3AM-0101	33.5	20.0	19.0	005-0882-03	N/A
C8AJ-0100	33.5	20.0	19.0	005-0882-03	N/A
C8AJ-0200	33.5	20.0	19.0	005-0882-03	N/A
ENAG-A100	24.0	17.9	13.3	005-0882-00 / -09	505-7066-01
E3AM-A101	26.2	18.3	16.0	005-0882-01 / -11	505-7066-01
CPAK-0150	33.5	20.0	19.0	005-0882-03	N/A
C3AH-0150	33.5	20.0	19.0	005-0882-03	N/A
C3AM-0303	39.0	30.0	29.5	005-0882-05	N/A
C7AB-0150	33.0	20.0	19.0	005-0882-03	N/A
C7AB-0200	33.5	20.0	19.0	005-0882-03	N/A
C7AB-0300	39.0	30.0	29.5	005-0882-05	N/A
C8AL-0151	33.5	20.0	19.0	005-0882-03	N/A
C8AL-0200	33.5	20.0	19.0	005-0882-03	N/A
CNAG-0200	33.5	20.0	19.0	005-0882-03	N/A
C8AJ-0300	39.0	30.0	29.5	005-0882-05	N/A
C8AM-0202	33.5	20.0	19.0	005-0882-03	N/A
CJAL-0300	39.0	30.0	29.5	005-0882-05	N/A
CLAL-0300	39.0	30.0	29.5	005-0882-05	N/A
CPDK-0300	39.0	30.0	29.5	005-0882-05	N/A
CPDK-0600	44.0	36.0	31.5	005-0882-05	N/A
CPDK-0750	44.0	36.0	31.5	005-0882-05	N/A
CJDL-0400	39.0	30.0	29.5	005-0882-05	N/A
CMDL-0400	39.0	30.0	29.5	005-0882-05	N/A
C8DJ-0500	39.0	30.0	29.5	005-0882-05	N/A
C8DJ-0501	39.0	30.0	29.5	005-0882-05	N/A
C8DJ-0750	44.0	36.0	31.5	005-0882-05	N/A
C8DJ-1000	39.0	66.0	36.0	005-0882-06	N/A

Flex-Line hoods for scroll condensing units

Hood Selection

Copeland® Model	Dimensions (in.)			Hood	Flex-Line Hood
	L	W	H		
Copeland Scroll®					
FTAH-A13Z	24.0	18.3	16.3	005-0882-01 / -10	505-7066-01
FJAM-A15Z	24.0	18.3	16.3	005-0882-01 / -10	505-7066-01
FTAH-A15Z	24.0	18.3	16.3	005-0882-01 / -10	505-7066-01
FFAS-A20Z	25.2	34.0	19.0	005-0882-01 / -11	505-7066-02
FFAS-A25Z	25.2	34.0	19.0	005-0882-01 / -11	505-7066-02
FFAS-A30Z	25.2	34.0	19.0	005-0882-01 / -11	505-7066-02
FFAS-A35Z	25.2	34.0	19.0	005-0882-01 / -11	505-7066-02
FFAS-A40Z	28.2	44.1	26.8	005-0882-04	505-7066-03
FFAS-A50Z	28.2	44.1	26.8	005-0882-04	505-7066-03
FFAS-A60Z	28.2	44.1	26.8	005-0882-04	505-7066-03
FPAN-070Z	28.5	44.0	36.8	005-0882-04	N/A
FPAN-080Z	28.5	44.0	36.8	005-0882-04	N/A
FPAN-091Z	28.5	44.0	36.8	005-0882-04	N/A
FPAN-101Z	28.5	44.0	36.8	005-0882-04	N/A
DJAL-015Z	25.2	34.3	19.0	005-0882-01 / -11	505-7066-02
DJAL-020Z	25.2	34.3	19.0	005-0882-01 / -11	505-7066-02
DJAL-022Z	25.2	34.3	19.0	005-0882-01 / -11	505-7066-02
DJAL-026Z	25.2	34.3	19.0	005-0882-01 / -11	505-7066-02
DJAL-030Z	25.2	34.3	19.0	005-0882-01 / -11	505-7066-02
DJAL-041Z	28.2	44.1	26.8	005-0882-04	505-7066-03
DJAL-051Z	28.2	44.1	26.8	005-0882-04	505-7066-03
DJAL-060Z	28.2	44.1	26.8	005-0882-04	505-7066-03

Refrigerants/Lubricants Approved for Use in Copeland® Compressors

	Refrigerants	Similar To	Application		Lubricant Choices			Comments
			Retروفیت	New	Preferred	Alternate #1	Alternate #2	
Ozone Depleting	CFCR-12		L,M		MIN	AB & MIN		Phased Out in 1996
	CFCR-502		L,M		MIN	AB & MIN	POE-32	Phased Out in 1996
	HCFC R-22		L,M,H		MIN	AB & MIN	POE-32	No New Equipment 2010
Interims	HCFC R-401A	R-12	M,H		AB & MIN	POE-32 & MIN	POE-32	Service Only Suva® MP39
	HCFC R-401B	R-12	L,M		AB & MIN	POE-32 & MIN	POE-32	Service Only Suva® MP66
	HCFC R-402A	R-502	L,M		AB & MIN	POE-32 & MIN	POE-32	Service Only Suva® HP80
	HCFC R-402B	R-502	L,M		AB & MIN	POE-32 & MIN	POE-32	Service Only Suva® HP81
	HCFC R-408A	R-502	L,M		AB & MIN	POE-32 & MIN	POE-32	Service Only FX10
	HCFC R-409A	R-12	L,M		AB & MIN	POE-32 & MIN	POE-32	Service Only FX56
	HFC R-134a	R-12	M,H		POE-32			
Non-Ozone Depleting	HFC R-404A	R-502	L,M	L,M	POE-32			Suva® HP62, Forane® FX70
	HFC R-507	R-502	L,M	L,M	POE-32			Genetron® AZ50
	HFC R-407A	R-22	L,M	L,M	POE-32			
	HFC R-407C	R-22	L,M,H	L,M,H	POE-32			Suva® 9000/KLEA 66
	HFC R-410A			M,H	POE-32			ZP & ZB KCP Copeland Scroll® Models Only
	HFC R-422A/D	R-22	L,M		MIN	POE-32	AB	Discus® Supermarket Racks Only
	HFC R-438A	R-22	L,M		MIN	POE-32	AB	Discus® Supermarket Racks Only; ISCEON® MO99
R-704 Helium				PAG			ZC Copeland Scroll® Models Only	
R-744 CO ₂				POE*			ZO Copeland Scroll® Models Only	

Legend:

MIN: Mineral Oil (Copeland® 46BWMO, Sonneborn Suniso 3GS), Chevron/Texaco Capella WF32) Mineral oils are interchangeable for 'top off' purposes

AB: Alkyl Benzene Oil (Copeland® Ultra 200, Shrieve Zerol 200 TD, Sonneborn Suniso AKB200A, Shell 2212)

POE 32: Polyester Oil (Copeland® Ultra 32-3MAF, Lubrizol Emkarate RL32-3MAF, Parker EMKARATE RL32-3MAF / (Virginia) LE323MAF, Nu Calgon 4314-66 (EMKARATE RL32-3MAF)

Hatcol 22 CC, Copeland® Ultra 22 CC & Mobil Arctic 22 CC (last three for 'top off' only)

POE*: Contact Application Engineer for oil details

PAG: Polyalkylene Glycol Oil (Lubrizol RPAG 62, UCON LB300X)

POE-32 & MIN: Minimum 50% POE

AB & MIN: Minimum 50% Alkyl Benzene

L: Low Temperature Application (Refrigeration) For R-407A, R-407C, R-422A/D, R-438A, Demand Cooling® is required for low temperature application - See AE guidelines for details

M: Medium Temperature Application (Refrigeration)

Hi: High Temperature Application (Air-Conditioning, Heat Pump, Refrigeration)

Spectronics AR-GLO 4/E Fluorescent Leak Detection Dye is approved for HFC/POE and HCFC/Mineral Oil usage at the manufacturer's recommended concentrations.

For specific product availability and performance data refer to Emerson Climate Technologies, Inc. sales literature Refer To Application Bulletins, Change-Over Guidelines And MSDS Sheets for additional information at EmersonClimate.com



Emerson, Copeland, Copeland Scroll, Demand Cooling, and Discus are trademarks of Emerson Electric Co. or one of its affiliated companies. © 1993 Emerson Climate Technologies, Inc. All rights reserved. Printed in the USA.



EmersonClimate.com

2011DS-4 (2/11) Emerson, Copelametic, Copeland, Copeland Scroll, Copevap and SystemPro are trademarks of Emerson Electric Co. or one of their affiliated companies.
©2011 Emerson Climate Technologies, Inc. All rights reserved. Printed in the USA.

EMERSON. CONSIDER IT SOLVED.™