

UEI

TEST INSTRUMENTS™

C095

Carbon Monoxide Detector

INSTRUCTION MANUAL

ENGLISH

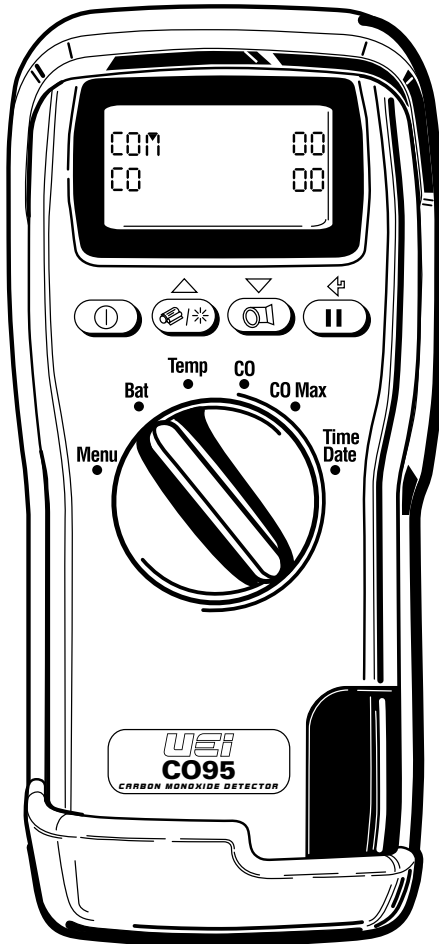

**Test Equipment
Depot**

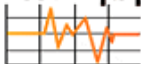

1-800-517-8431

99 Washington Street
Melrose, MA 02176
Phone 781-665-1400
Toll Free 1-800-517-8431



Visit us at www.TestEquipmentDepot.com

TABLE OF CONTENTS

INTRODUCTION	3
Safety.....	3
CONTROLS AND INDICATORS	4
OPERATING INSTRUCTIONS	6
Before Using Every Time.....	6
Appliance Measurements	6
CFK1 – Optional Chemical Filter Kit (NOx Filter).....	7
Ambient Air Measurements.....	7
Printing Test Information.....	7
After Using The Meter	8
TROUBLESHOOTING	8
SPECIFICATIONS	8
MAINTENANCE	9
Periodic Service.....	9
Cleaning.....	9
Battery Replacement.....	9
ELECTROMAGNETIC COMPATIBILITY (EMC)	10
GLOSSARY OF TERMS	10
WARRANTY AND SERVICE INFORMATION	12

INTRODUCTION

The C095 is configured with a long-life CO sensor. The C095 meter tests CO levels in heating appliances, ambient air, around fossil fueled appliances like cookers and grills. It also helps you test residential and commercial CO alarms and also shows CO MAX - the maximum level of CO measured. The C095 can also be used as a digital thermometer, ideal for testing hot water or refrigeration.

FEATURES INCLUDE

- Long-life (5 years) CO sensor
- Measure ambient CO levels
- Measure CO concentration in flue gas
- CO Max capture
- CO accurate to $\pm 5\%$ of reading
- Temperature measurement
- Auto-zero at power up
- Link to optional infrared printer

SAFETY NOTES

Before using this meter, read all safety information carefully. In this manual the word "**WARNING**" is used to indicate conditions or actions that may pose physical hazards to the user. The word "**CAUTION**" is used to indicate conditions or actions that may damage this instrument.



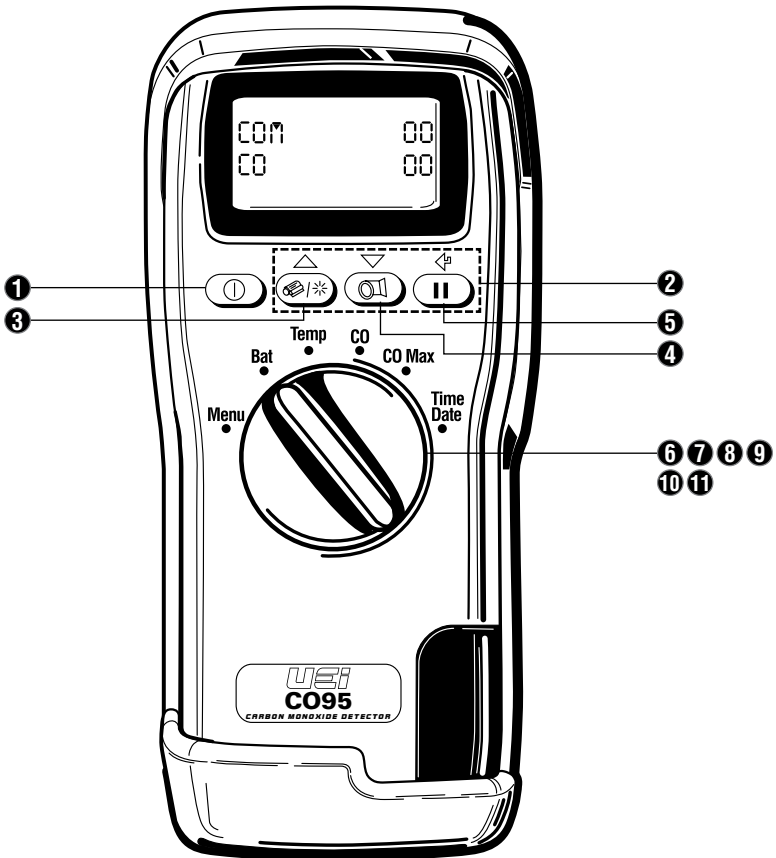

WARNING! This meter extracts combustion gases that may be toxic in relatively low concentrations. These gases are exhausted from the back of the instrument. This meter must only be used in well-ventilated locations by trained and competent persons after due consideration of all the potential hazards.

CONTROLS AND INDICATORS



1. POWER PUSH-BUTTON

- Press “” button to switch the unit ON in fresh air outside the property about to be tested. This lets the meter auto calibrate its sensors properly.
- When turned on the meter beeps four times and displays the top line date, time and model number. The bottom line counts down from 60 until the sensors are ready to use - This normally takes 20 - 30 seconds but may take longer as sensors get older. If the meter will not auto calibrate, its sensors need to be replaced or recalibrated by an authorized repair center.
- When countdown is finished the displays top line shows the last selected function and the bottom line displays whatever the rotary dial is turned to.
- Press “” button again to switch the meter OFF. The display counts down from 30 with the pump on to clean the sensors with fresh air - If the probe is still connected, make sure the meter and probe are in fresh air.
- Press “**HOLD/ENTER**” if you want to stop the countdown and return to taking measurements.

2. UP/DOWN/ENTER BUTTONS

- Press the “**DOWN**” button for more than 1 second to change the displays top line. The rotary dial changes the displays bottom line.

***Example:** The meter will display CO on its top line and temperature on its bottom line if you turn the rotary dial to “**TEMP**” and push the “**DOWN**” button until CO is displayed on the top line.*

- Use the “**UP/DOWN/ENTER**” keys to change settings (such as time and date) when the rotary dial is turned to “**MENU**”.

3. PRINT/BACKLIGHT BUTTON

- Press and release “**PRINT/BACKLIGHT**” quickly to switch backlight on or off.
- Press for more than 1 second before releasing to start the meter printing. The meter will display “**PRINTING**”.

4. PUMP ON/OFF BUTTON

- The meter normally operates with the pump on. Press “**PUMP**” quickly to switch the pump off and on.
- When the pump is switched off, the meter displays “**PUMP OFF**” approximately every 30 seconds.

5. FREEZING THE DISPLAY

- Press “**HOLD/ENTER**” to freeze all readings. The display flashes and can be printed by pressing “**PRINT**” key. Press “**HOLD/ENTER**” again for live measurements.

6. MENU

- Rotate the dial to “**MENU**” and use the “**UP**” or “**DOWN**” buttons to select the following function for change:
 1. Time - Uses “Military” time as standard: 7am = 07:00, 7pm = 19:00
 2. Date - Select from MM/DD/YY, YY/MM/DD or DD/MM/YY
 3. The display’s top line - select from the settings listed below
 4. Temperature units - °F or °C
 5. The display screen contrast
 6. Language - select from English, French, Spanish, Italian and German
 7. Service - Password protected for authorized service personnel only
- When you have selected the function to change, press “**ENTER**” to select.
- Repeat this as the menu “**drops down**” to select (using the “**ENTER**” key) and change (using the “**UP**” and “**DOWN**” keys) the function. The final, logical “**ENTER**” returns you to the main menu display.
- To exit the menu function at any time, rotate the dial to another position - Unless the final logical “**ENTER**” is pressed, no changes are made.

7. **Time & Date:** Displays time and date.

8. **Temp:** Displays the measured temperature in °F or °C.

- If the temperature sensor is broken or open circuit it displays 000.

9. **CO:** Displays Carbon Monoxide (CO) values in PPM.

10. **CO MAX:** Displays the maximum CO value in PPM recorded during the test

11. **BAT:** Displays estimated battery life.

- If battery voltage falls below a pre-set limit, the display flashes “**LOW BAT.**” every 10 seconds.

OPERATING INSTRUCTIONS

BEFORE USING EVERY TIME

Check for the following:

- The particle filter is not dirty
- The water trap and probe line are empty of water
- All hose and thermocouple connections are properly made
- The probe is sampling ambient FRESH air
- The water trap and drain plug are fitted correctly to the instrument
- The temperature probe is connected if required

APPLIANCE MEASUREMENTS

Place the CO95’s probe into the appliance’s sampling point. The ideal sampling point is at least two flue diameters downstream of any bend.

Put the probe tip in the flue center. With balanced flue, make sure the probe is positioned far enough into the flue so no air can “back flush” into the probe.

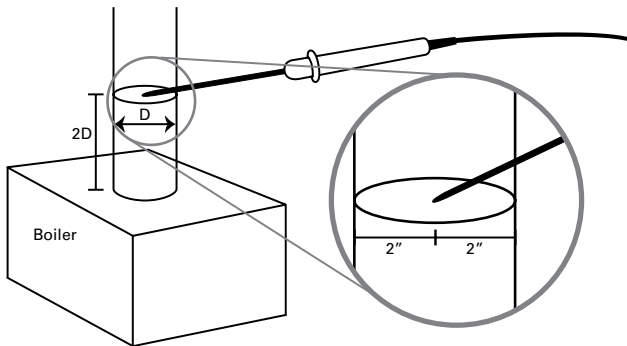

Taking an appliance test

Make sure you do not exceed the meter’s operating specifications.

In particular:

- Do not exceed the probe’s maximum temperature
- Do not exceed the meter’s internal temperature operating range
- Do not put the meter on a hot surface
- Do not exceed the water trap’s levels
- Do not let the meter’s particle filter become dirty and blocked

Press “**HOLD**” first to “**freeze**” the readings before printing, then press “**PRINT**”.

CFK1 – OPTIONAL CHEMICAL FILTER KIT (NOX FILTER)

CO sensors may respond to gases other than CO, resulting in slightly elevated readings. On low NOx equipment this impact will be very small, often less than the tolerance of your meter. If you anticipate high levels of SO2 or NOx, UEI recommends using our CFK1, in-line chemical filter. The CFK1 will remove NOx and SO2 from the gas sample, allowing a true view of the CO only. The CFK1 is compatible with most portable CO and Flue Gas Analyzers, installs on the sample line before the instrument, and need for replacement is easy to determine.

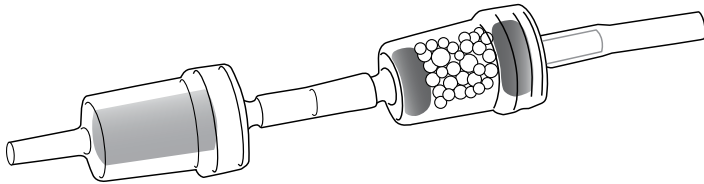

AMBIENT AIR MEASUREMENTS

When testing for CO in rooms, make sure the meter has been switched on in outdoor fresh air before the meter is calibrated.

After the countdown is finished and the meter is correctly set up, take the meter into the room to be tested, make sure its pump is on and use the probe to draw in ambient air for the meter to measure.

- Only switch on the meter in OUTDOOR, FRESH AIR
- Do not exceed the meter's internal temperature operating range
- Do not put the meter on a hot surface
- Do not expose yourself and others to dangerous levels of CO

PRINTING TEST INFORMATION

An optional accessory for the C095 is an infrared thermal printer. Read the manual supplied with the printer prior to operation. Connection to the C095 is detailed below.

- **Infrared thermal printer** - this does not require a cable to transmit the data but uses an infrared (IR) link similar to a TV remote control. The IR emitter is positioned on the top of the C095 and the bottom of the printer. Ensure they are pointing at each other and within 3 feet (1 meter), with no obstructions in the way. Data may be lost if transmission is interrupted. Keep the C095 pointing at the printer until the printout has finished.

During tests the C095 will print data on request. With the analyzer showing the **"MAIN DISPLAY"** press

"  " and current data will be sent to the printer.

The display will show **"PRINTING"** until data transmission is complete.

UEI C095		
503 644 8723		
06-26-02		14:27
SMOKE:		
NATURAL GAS		
CO	PPM	00
CO MAX	PPM	
TEMP.	F	----

AFTER USING THE METER

After using the meter to test appliances, remove it's probe from the flue - IT WILL BE HOT - and let it cool. Do not put the probe in water which will be sucked into the meter, damaging its pump and sensors.

When the meter readings return to ambient levels, turn the meter off. The meter counts down from 30 before switching off with the pump running to self-clean its sensors.

Empty the water trap and check filter prior to storage and next use.

TROUBLESHOOTING

If I See This Malfunction	Then Take This Corrective Action
<ul style="list-style-type: none">• CO sensor Error (----)	<ul style="list-style-type: none">• Meter was stored in a cold environment and is not at normal working temperature• CO sensor needs replacing
<ul style="list-style-type: none">• Batteries not holding charge• Meter not running on main adapter	<ul style="list-style-type: none">• Batteries exhausted• AC charger not giving correct output
<ul style="list-style-type: none">• Meter does not respond to flue gas	<ul style="list-style-type: none">• Water trap drain plug not installed• Particle filter blocked• Probe or tubing blocked• Pump not working or damaged with contaminants
<ul style="list-style-type: none">• Erratic temperature readings or 000 on display	<ul style="list-style-type: none">• Temperature plug reversed in socket• Faulty connection or break in cable or plug

SPECIFICATIONS

GENERAL SPECIFICATIONS

PARAMETER	RESOLUTION	ACCURACY	RANGE
Temperature Measurement	1.0°F/C	±5.0°F (2.0°C) ±0.3% reading	32-1112°F 0-600°C
Carbon Monoxide (CO) measurement	1 ppm	±10 ppm <100 ppm ±5% of reading >100 ppm	0-1000 ppm
Dimensions			
Weight	2.2 lb./1 kg		
Handset	7.9" (L) x 1.8" (D) x 3.5" (W) (200 mm x 45 mm x 90 mm)		
Probe	11.8" (L) x 0.25" (Dia) with 7.8" long stainless steel shaft (300 mm x 6 mm with 200 mm long stainless steel shaft)		
Ambient operating range	32° to 104°F (±0 to + 40°C) 10% to 90% RH non-condensing		
Battery life	4 AA cells > 8 hours using Alkaline AA cells		
AC adapter (optional)	Input: 110 V AC/220 V AC nominal, Output: 9 V DC regulated		

MAINTENANCE

PERIODIC SERVICE

 **WARNING!** Repair and service of this instrument is to be performed by qualified personnel only. Improper repair or service could result in incorrect or erroneous reading from the meter. Perform only those maintenance tasks that you are qualified to do.

These guidelines will help you attain long and reliable service from your meter:

- Calibrate your meter annually to ensure it meets original performance specifications
- Keep your meter dry. If it gets wet, wipe dry immediately - Liquids can degrade electronic circuits
- Whenever practical, keep the meter away from dust and dirt that can cause premature wear
- Although your meter is built to withstand the rigors of daily use, it can be damaged by severe impacts - Use reasonable caution when using or storing the meter

CLEANING

Periodically clean your meter's case using a damp cloth. **DO NOT** use abrasive, flammable liquids, cleaning solvents, or strong detergents as they may damage the finish, impair safety, or affect the reliability of the structural components.

BATTERY REPLACEMENT

Always use a fresh replacement battery of the specified size and type. Immediately remove the old or weak battery from the meter and dispose of it in accordance with your local disposal regulations. Batteries can leak chemicals that corrode electronic circuits. If your meter is not going to be used for a month or more, remove and store the battery in a place that will not allow leakage to damage other materials.

To install a new battery, follow these procedures:

1. Turn off the meter.
2. Remove the rubber boot from the meter, starting at the top.
3. Place meter face down on a clean cloth.
4. Remove battery compartment cover.
5. Remove and discard the old batteries. Always dispose of old batteries promptly in a manner with local disposal regulations.
6. Insert (4) AA alkaline batteries noting "+" and "-" diagram directions in battery compartment.

 **WARNING!** Under no circumstances should you expose batteries to extreme heat or fire as they may explode and cause injury.

ELECTROMAGNETIC COMPATIBILITY (EMC)

European Council Directive 89/336/EEC requires electronic equipment not to generate electromagnetic disturbances exceeding defined levels and have adequate immunity levels for normal operation. Specific standards applicable to this meter are stated below.

As there are electrical products in use pre-dating this Directive, they may emit excess electromagnetic radiation levels and, occasionally, it may be appropriate to check the meter before use by:

- Use the normal start up sequence in the location where the meter will be used.
- Switch on all localized electrical equipment capable of causing interference.
- Check all readings are as expected. A level of disturbance is acceptable.
- If not acceptable, adjust the meter's position to minimize interference or switch off, if possible, the offending equipment during your test.

At the time of writing this manual UEI and Kane International Ltd are not aware of any field based situation where such interference has occurred and this advice is only given to satisfy the requirements of the Directive.

This product has been tested for compliance with the following generic standards and is certified to be compliant.

EN 50081-1 & EN 50082-1



Specification EC/EMC/KI/C100A details the specific test configuration, performance and conditions of use.

GLOSSARY OF TERMS

- **TEMP:** Temperature measured by the probe in Fahrenheit (°F) or Centigrade (°C). It displays "----" if the probe is disconnected.
- **CO:** Carbon Monoxide reading displayed in ppm (parts per million). "----" is displayed if there is a fault with the CO sensor or the meter has not set to zero correctly, switch off meter and try again.
- **CO MAX:** Maximum CO level recorded while the meter is switched on.
- **BAT:** Displays battery power available in %.
- When the **"BAT"** symbol is nearly empty it indicates the batteries are at less than 10% of charge and should be replaced, readings may be affected if used with low batteries.
- **DATE:** Date order can be changed using the menu function. Date is recorded when each combustion test is printed.
- **TIME:** Time is shown in hours and minutes, expressed in "Military" time or the 24hr clock. Time is recorded when each combustion test is printed.



C095

Carbon Monoxide Detector

Limited Warranty

The C095 is warranted to be free from defects in materials and workmanship for a period of five years from the date of purchase. If within the warranty period your instrument should become inoperative from such defects, the unit will be repaired or replaced at UEi's option. This warranty covers normal use and does not cover damage which occurs in shipment or failure which results from alteration, tampering, accident, misuse, abuse, neglect or improper maintenance. Batteries and consequential damage resulting from failed batteries are not covered by warranty. Annual calibration is not covered as a warranty item.

Any implied warranties, including but not limited to implied warranties of merchantability and fitness for a particular purpose, are limited to the express warranty. UEi shall not be liable for loss of use of the instrument or other incidental or consequential damages, expenses, or economic loss, or for any claim or claims for such damage, expenses or economic loss. A purchase receipt or other proof of original purchase date will be required before warranty repairs will be rendered. Instruments out of warranty will be repaired (when repairable) for a service charge. Return the unit postage paid and insured to:

This warranty gives you specific legal rights. You may also have other rights which vary from state to state.

PLEASE



RECYCLE