

NO: 11-11

DATE: 08/10/11

TO: EMERSON CLIMATE TECHNOLOGIES WHOLESALERS
-EXECUTIVES
-PRODUCT MANAGERS
-EMERSON® TECHNICAL SPECIALISTS
-BRANCH PERSONNEL

SUBJECT: CRN, CRP AND CRT BILL OF MATERIAL CONSOLIDATION

CRN, CRP and CRT compressor models will be consolidated over the next couple of months, but in most cases the legacy replacement models wholesalers have typically purchased will continue to be available. The other bills of material with lower sales volumes will be phased out by the end of September 2011. -170, -270, and -970 bills of material will continue to be produced. You should expect to see shipments with these changes starting in the Fall of 2011.

Our consolidation of these models will result in a standard configuration. All three bills of material will have a 7/8-inch inside diameter (ID) elbow-up suction port and 1/2-inch inside diameter (ID) elbow-up (5/8-inch outside diameter) discharge port, with a standard foot arrangement of 7-½ inches by 7-½ inches, or "A" Type mounting. They will also have a 3/8-inch elbow-up process tube and will include a wrap-around style crankcase heater, which will not be installed on the compressor.

See **Figure 1** for the configuration details and **Figure 2** for the crankcase heater mounting location. **Figure 3** lists the components included with the -970 service model. **Figure 4** lists additional components that might be needed and that are available from Emerson's distribution center.

Figure 1- Configuration Details

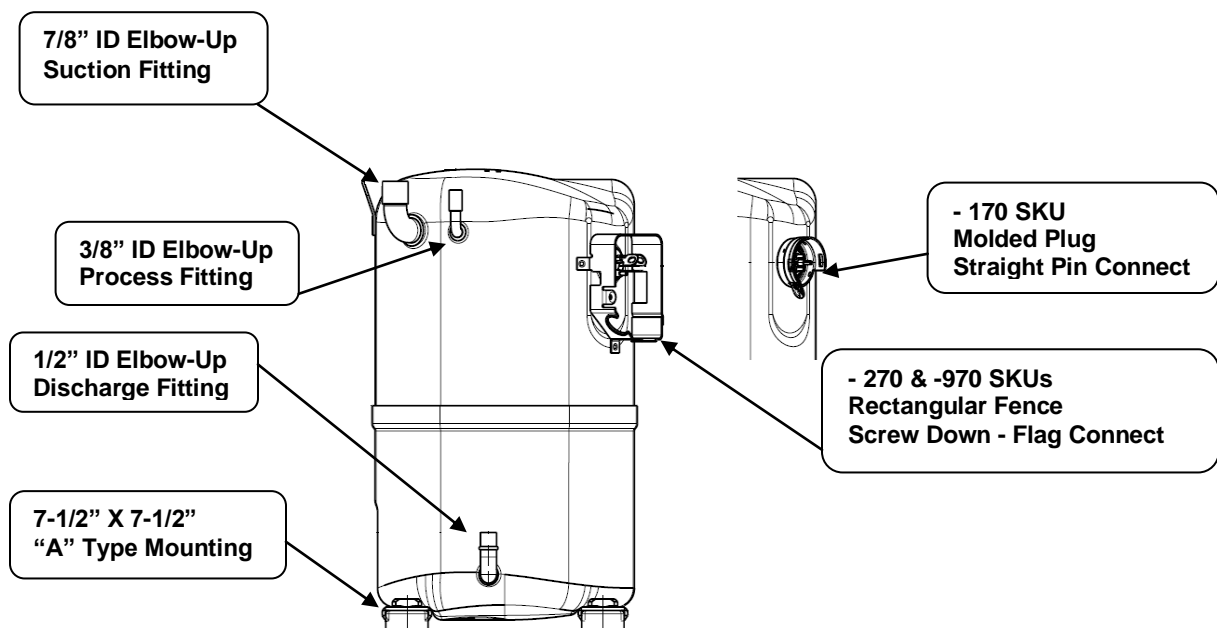

Figure 2 – Crankcase Heater Mounting Location

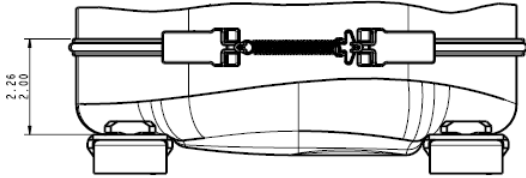

Figure 3 – Service Kit Components

- Terminal Screw: 521-0191-00
- Mounting Parts: 527-0116-00
- Poly Crank Case Heater: 918-0088-04 (For PFV or TF5)
 918-0088-05 (For TFD or TFE)

Figure 4 – Additional Components

- Molded Plug: 529-0060-04
- Adaptors: 536-0177-00
- Rotalock Adaptors: 998-0334-00
- 2 Port Service Valve Kit: 998-0510-90 (For 7/8" ID)
 998-0510-69 (For 5/8" ID)
- Power Cable Conduit Kit: 998-0529-04
- Conduit Box Crankcase Heater: 918-0076-02 (for PFV, PFJ, or TF5)
 918-0076-03 (for TFD, TFE)
- Electrical Components:

Models	Start Cap	Run Cap	Relay
CRN5-0500-PFV & CRNQ-050E-PFV	914-0006-10	914-0037-10	940-0001-68
CRP5-0450-PFV & CRT5-0450-PFV	914-0006-03	914-0037-19	940-0001-68

These are the models wholesalers will continue to use for replacement purposes:

CRN5-0500-PFV-970	CRP5-0450-PFV-970
CRN5-0500-TF5-970	CRP5-0450-TF5-970
CRN5-0500-TFD-970	CRP5-0450-TFD-970
CRN5-0500-TFE-970	CRP5-0450-TFE-970
CRNQ-050E-PFV-970	CRT5-0450-PFV-970
CRNQ-050E-TF5-970	CRT5-0450-TFD-970
CRNQ-050E-TFD-970	CRT5-0450-TF5-970

Bolded items indicate new wholesaler models.

In the Fall of 2011 we will supersede any new orders for the legacy models to the new replacement models. 2012 Preseason orders and any regular orders will be changed to the new model numbers.

Contact your Distribution Services Sales Manager or Customer Service with any questions regarding this information.