



# Figure # 5049F

Brass Ball Valve (3/8"-3")

## Product Features

- 150#WSP / 600# WOG
- Forged Brass Body
- Full Port
- Adjustable Packing
- Solder Ends
- Blowout Proof Stem
- NSF through 2"
- MSS-SP-110



Pressure/Temperature Ratings	
600 PSI from 15F to 160F	150 PSI MAX at 366F

Connection Working Pressure				
Solder used in joints	Working Temp deg. F	Maximum working pressure (PSI)		
		3/8"-1"	1-1/4"-2"	2-1/2"-3"
95-5 Tin Antimony (ASTM B32 grade 95TA)	100	500	400	300
	150	400	350	275
	200	300	250	200
	250	200	175	150

## Materials & Specifications

Item	Description	Material	Specification
1	Body	Brass	B283 C37700
2	End Piece	Brass	B283 C37700
3	Ball	Brass/Chrome Plated	B283 C37700
4	Seat	PTFE	PTFE
5	Stem	Brass	B124 C37700
6	Packing	PTFE	PTFE
7	Packing Nut	Brass	B124 C37700
8	Handle	Zinc plated steel	A36 Dacromet
9	Handle Nut	Zinc plated steel	A36 Dacromet
10	I.D. Information	N/A	N/A

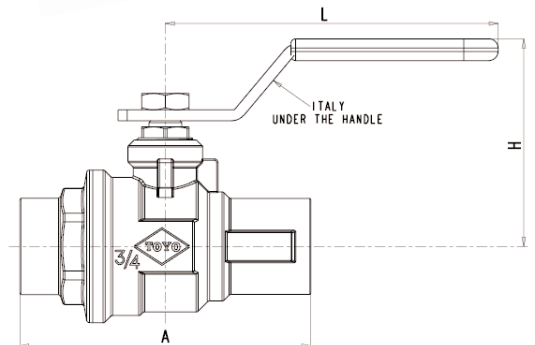
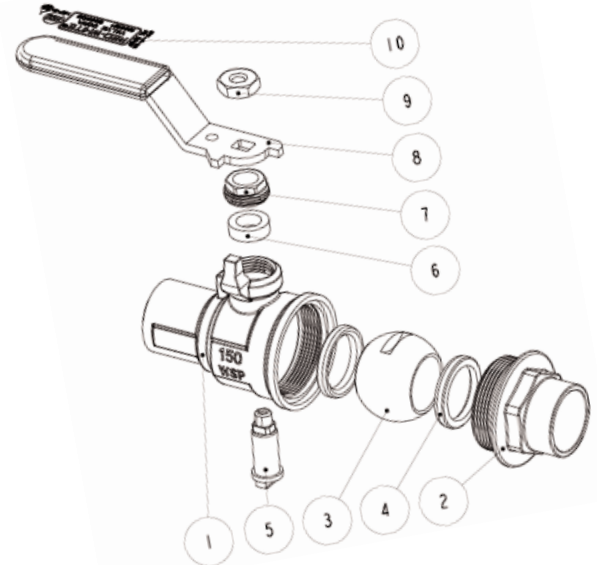

## Dimensions, Weights (inches-lbs.) & Valve Data

Size	3/8"	1/2"	3/4"	1"	1-1/4"	1-1/2"	2"	2-1/2"	3"
Ø	0.502-0.506	0.627-0.631	0.877-0.881	1.128-1.131	1.378-1.381	1.628-1.632	2.128-2.132	2.628-2.632	3.128-3.132
A	1.89	2.6	3.15	3.31	3.86	4.53	5.51	6.65	7.72
C	0.51	0.51	0.75	0.91	0.97	1.09	1.34	1.5	1.69
H	1.55	2.13	2.24	2.57	2.79	3.28	3.58	4.7	5.15
L	3.19	3.6	3.6	4.98	4.98	5.57	5.57	11.07	11.07
P	0.39	0.59	0.79	0.98	1.26	1.57	1.97	2.56	3.07
Cv	8	15	30	60	110	130	360	450	620
Wt.-lbs.	0.29	0.56	0.79	1.21	2.04	3.02	4.56	8.87	13.34

