

5-5/8" Diameter (Open Lead End) - Outdoor Ball and Sleeve Bearing

Condensers - Heat Pump - Refrigeration

Features:

- Energy Efficient \$
- Permanent Split Capacitor
- Class B Insulation
- Ball or Sleeve Bearing
- 1/2" Dia. Flatted Shaft
- 26" (Minimum) to 48" Leads
- 60 HZ
- All Angle Mount
- 60°C Ambient
- Auto Protector
- Reversible
- 4 and 6 Pole
- Extended Thru Bolts



F1106

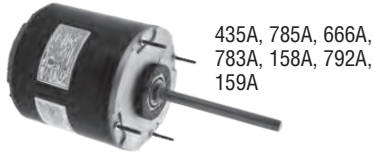

435A, 785A, 666A,
783A, 158A, 792A,
159A



FH1056S



F1076SV1



FH1056S



FH1056, FH1054,
F1076S, FS1076S,
F1076A, FH1076

DRIPPROOF – VERTICAL SHAFT UP/HORIZONTAL

HP	RPM	Volts	Speeds	Amps		Insulation Class	Ambient	Stock Number	Bearings	Capacitor	Dim. Ref.	Notes
				Rated	Max.							
1/2	1075	460	1	1.2	1.3	B	60°C	FH1056S	Ball	10MFD-370V	9	9,54,98,\$
1/2	1075	460	1	1.7		B	60°C	435A	Ball	7.5MFD-370V	10	147,\$
1/2	1075	460	1	1.6		B	60°C	785A	Sleeve	7.5MFD-370V	11	9,25,309,\$
1/2	1075	460	2	1.9		B	60°C	FH1056	Ball	10MFD-370V	12	9,25,54,67,\$
1/2	1625	208-230	1	3.9		B	60°C	666A	Sleeve	5MFD-370V	14	147,\$
1/2	1625	460	2	1.4	1.8	B	60°C	FH1054	Ball	7.5MFD-370V	13	6,9,25,54,311,\$
1/2	1625	460	2	1.6		B	60°C	783A	Ball	7.5MFD-370V	15	9,25,38,\$
3/4	1075	208-230	1	3.5	4.2	B	60°C	F1076S	Ball	15MFD-370V	13	9,25,\$
3/4	1075	208-230	1	4.0	5.0	B	60°C	FS1076S	Sleeve	10MFD-370V	1	9,25,318,\$
3/4	1075	208-230	1	5.3		B	60°C	F1076SV1	Ball	12.5MFD-370V	2	9,71,121,311,\$
3/4	1075	208-230	2	3.5	4.2	B	60°C	F1076	Ball	15MFD-370V	14	9,25,\$
3/4	1075	208-230	2	3.5	4.2	B	60°C	F1076A	Ball	15MFD-370V	3	9,25,270,\$
3/4	1075	460	1	2.1		B	60°C	158A	Ball	10MFD-370V	4	147,\$
3/4	1075	460	1	2.2		B	60°C	792A	Sleeve	10MFD-370V	5	9,25,309,\$
3/4	1075	460	2	2.2		B	60°C	FH1076	Ball	15MFD-370V	6	9,25,54,67,\$
1	1075	208-230	1	4.8	6.0	B	60°C	F1106	Ball	15MFD-370V	7	9,25,\$
1	1075	230/460	1	4.7/2.4		B	60°C	159A	Ball	15MFD-370V	8	147,\$

Notes:

- 6. 60/50 HZ
- 9. Reversing Plug
- 25. Has hex mounting hub on both ends for cradle base mounting
- 54. Triple build wire for greater high voltage insulation
- 67. Rewire for second speed
- 71. No hubs on either end
- 98. 1/2" hub on shaft end and slinger
- 121. Stronger 3/4 HP required for some applications
- 147. Resilient mounting rings included for refrigeration applications
- 270. 5/8" keyed shaft with flat
- 309. 1/2" extended thru bolts
- 311. 1/2" dia. shaft, single flat

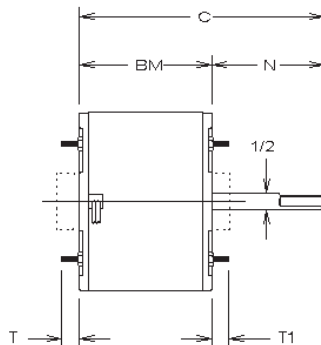

Approximate Dimensions

Ref.	BM	C	N	T	T1
1	5.61	12.03	6.42		1.50
2	5.99	9.99	4.00		
3	5.36	9.75	4.39		1.55
4	5.61	11.66	6.05		.98
5	5.74	11.74	6.00		.49
6	5.74	12.18	6.44		1.63
7	6.11	12.55	6.44		1.63
8	5.74	11.79	6.05		1.12
9	5.61	9.61	4.00	.88	.95
10	5.11	11.16	6.05		1.00
11	5.25	11.25	6.00		.49
12	5.86	12.30	6.44		1.63
13	5.36	11.80	6.44		1.63
14	4.86	10.88	6.02		1.11
15	5.24	11.03	6.06		.49