

CoreSense™ Diagnostics v2.11 for Copeland Discus™ Compressors

Table of Contents

<p>1.0 Overview</p> <p>1.1 Functionality</p> <p style="padding-left: 20px;">1.1.1 Diagnostics</p> <p style="padding-left: 20px;">1.1.2 Communication</p> <p style="padding-left: 20px;">1.1.3 Fault History</p> <p>1.2 Features</p> <p style="padding-left: 20px;">1.2.1 Compressor Protection</p> <p style="padding-left: 20px;">1.2.2 Remote Reset</p> <p style="padding-left: 20px;">1.2.3 Failsafe Operation</p> <p style="padding-left: 20px;">1.2.4 Welded Contactor Protection</p> <p style="padding-left: 20px;">1.2.5 Crank Case Heater Control</p> <p style="padding-left: 20px;">1.2.6 Start-up Delay Feature</p> <p style="padding-left: 20px;">1.2.7 “Jog” feature</p> <p style="padding-left: 20px;">1.2.8 Dipswitch Settings</p> <p>1.3 Modulation Control</p> <p>1.4 Application Restrictions</p> <p>2.0 Installation Instructions</p> <p>2.1 Mounting and Installation</p> <p>2.2 Terminal Box Connections</p> <p style="padding-left: 20px;">2.2.1 Current Sensing Module</p> <p style="padding-left: 20px;">2.2.2 Fan Connections</p> <p>2.3 Controller Requirements</p> <p>2.4 Communications Network</p> <p>2.5 Network Terminations and Cable Routing</p> <p style="padding-left: 20px;">2.5.1 RS485 Wiring Types</p> <p>2.6 CoreSense Diagnostics v2.11 Service Instructions</p> <p>2.7 Compatibility of Service Compressors</p> <p>2.8 CoreSense Diagnostics v2.11 Model Numbers</p> <p>3.0 Quick Start Guide</p> <p>4.0 Commissioning Procedure</p> <p>4.1 Dip Switch Configuration</p> <p>4.2 Network Setup</p> <p>4.3 Enhanced Suction Group Setup</p> <p>4.4 Associations</p> <p>4.5 Proofing</p> <p>4.6 Failsafe</p> <p>4.7 CoreSense Diagnostics v2.11 Setup Screens</p> <p>4.8 Unloader Configuration</p>	<p>4.9 Demand Cooling Configuration</p> <p>4.10 Crankcase Heater Control</p> <p>4.11 Anti Short Cycle</p> <p>4.12 MCC Value</p> <p>4.13 Compressor Voltage</p> <p>4.14 Compressor Frequency</p> <p>4.15 Language</p> <p>4.16 Voltage Balance</p> <p>4.17 Inputs</p> <p>4.18 Outputs</p> <p>4.19 ID Configuration</p> <p>4.20 CoreSense Diagnostics v2.11 Navigation</p> <p>5.0 Stand Alone Installation & Operation</p> <p>6.0 Compressor Status Codes & Troubleshooting</p> <p>6.1 Definitions</p> <p>6.2 Event Priority and Troubleshooting</p> <p style="padding-left: 20px;">6.2.1 Event Priority & Anti Short Cycle Delay</p> <p style="padding-left: 20px;">6.2.2 LED Interpretation</p> <p>6.3 Event Priority Table</p> <p>6.4 Emergency Work-Around Procedures</p> <p>6.5 Normal Running</p> <p>6.6 Normal Off</p> <p>6.7 Welded Contactor Warning</p> <p>6.8 Module Low Voltage Trip</p> <p>6.9 Connection Lost CT to Sensor</p> <p>6.10 Rack Controller Lockout</p> <p>6.11 Fault Temperature Probe</p> <p>6.12 Fail-Safe Inoperable</p> <p>6.13 Locked Rotor Trip / Lockout</p> <p>6.14 No Communication</p> <p>6.15 Motor Temperature Trip</p> <p>6.16 No Communication to Sensor Module</p> <p>6.17 Unloader Short</p> <p>6.18 Unloader Open</p> <p>6.19 Contactor Coil Lockout</p> <p>6.20 Protector Trip</p> <p>6.21 Voltage Imbalance Trip</p> <p>6.22 Low Suction Pressure Trip</p> <p>6.23 Phase Loss Trip / Lockout</p> <p>6.24 No 3-Phase Power</p> <p>6.25 Low Oil Pressure Warning / Lockout</p>
--	--

- 6.26 Control Module Failure Lockout
- 6.27 Sensor Module Failure
- 6.28 High Discharge Pressure Trip
- 6.29 Discharge Temperature Lockout
- 6.30 Current Overload Trip
- 6.31 Rapid Compressor Cycling with Constant Demand
- 6.32 Discharge Temperature Probe Fault Trip
- 6.33 Comp Low Voltage Trip/Lockout

7.0 Service Instructions

- 7.1 Control Module Replacement
- 7.2 Sensor Module Replacement
- 7.3 Installation Torque Values
- 7.4 Demand Cooling Service Procedures
- 7.5 Temperature Probe Inspection
- 7.6 Coil Inspection and Replacement
- 7.7 Injection Valve Replacement

8.0 Compressor Changeout Instructions

9.0 Removal Of 2D / 3D

10.0 Installation Of 2D / 3D

11.0 Removal Of 4D

12.0 Installation Of 4D

13.0 Removal Of 6D

14.0 Installation Of 6D

Appendix

- A. Terminal Box Diagram
- B. Harness Wiring Diagram
- C. Transformer Selection and Contactor Control
- D. Dielectric Test (Hi-Pot)
- E. Compressor Drawings
- F. Technical Support Information
- G. Service Parts List

1.0 Overview of the Copeland Discus Compressor with CoreSense Diagnostics v2.11

CoreSense Diagnostics v2.11 is now available on 2D, 3D, 4D and 6D compressors and integrates a number of important sensing and compressor protection functions. This product provides for on/off control of the compressor, capacity modulation (both conventional blocked suction and with Copeland Discus Digital™ capacity modulation) and for communication of the compressor status to the rack controller through a network using MODBUS for Intelligent Store communication protocol. Protection against low oil pressure, excessive discharge temperature, high discharge pressure and low suction pressure is standard on every Copeland Discus compressor with CoreSense Diagnostics. A 2-line liquid crystal display on the front of the compressor indicates the operational status of the compressor with a choice of 5 languages. An LED on the compressor control module indicates at a glance whether or not there are any compressor faults.

The “2.11 version” of this product provides the same basic protection and feature package as the previous “1.0” product, but with enhancements such as additional motor protection, accessory proofing and modulation control and demand cooling control.

Note: Throughout this manual the term “Control Module” refers to the electronic control box on the front of the compressor which contains the display and reset buttons. The “Sensor Module” is located inside the terminal box.

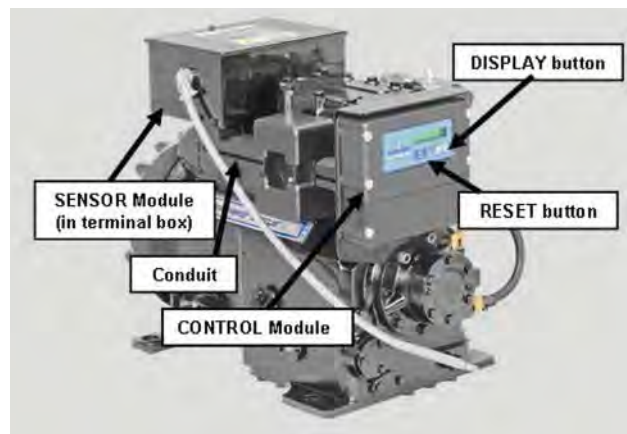

Figure 1.1

1.1 Functionality

1.1.1 Diagnostics

The status of the Copeland Discus compressor with CoreSense Diagnostics may be viewed at any time on the LCD display by pushing the Display button on the front of the control module. Normal conditions will be accompanied by a steady green LED (light emitting diode) on the front of the control module.

If a fault occurs that doesn’t interfere with the ability of the compressor to run, the LED will transition to a flashing green. The display will provide a description of the fault. This is referred to as a **warning**.

A **trip** or **lockout** condition will result in a flashing red LED. This is an indication of a condition that is keeping the compressor from running.

As with all conditions, the status of the compressor and the display code are transmitted to the rack controller where they may be viewed.

The status codes are discussed below in **Section 6.0**. Troubleshooting flowcharts to assist with resolution of each of the warnings, trips and lockouts may also be found in **Section 6.0**.

1.1.2 Communications

Communication between the rack controller and each CoreSense Diagnostics module is through an RS485 network with MODBUS. The two-wire communication cable is daisy-chained from one compressor to the next on each rack.

Compressor operations such as on/off control, modulation operation, transmission of compressor status and run proofing are all accomplished through the communication network. Password protected remote reset of certain compressor lockouts may also be done through the communication network if this functionality has been enabled through the controller. Capacity modulation functions are discussed in detail in **Section 1.3**, and in Commissioning / Suction Group Setup **Section 4.3**.

The Emerson Retail Solutions' controller E2, version 2.6 or higher, may be configured to send alarms for different levels of compressor faults, such as for **warnings, trips and lockouts**.

The **Failsafe** mode may be configured to turn the compressor on or off in the event of a communications failure. This configuration is accomplished via a dipswitch setting inside the lower cover of the control module.

1.1.3 Fault History

The 10 most recent warnings, trips or lockouts may be observed through the E2 alarm history screen. An 8 –day log of each fault is also available as well as an accumulated record for the history of the compressor.

Graphing features available with the E2 controller provide a powerful diagnostics tool to help understand the source of system or compressor faults. Date and time stamping of faults and alarms can help to associate the fault with system events (such as defrost cycles).

Like previous versions of Intelligent Store Discus, the CoreSense Diagnostics module will store the fault history record.

1.2 Features

1.2.1 Compressor Protection

Compressor protection may be in the form of a **TRIP**, where the compressor will be shut off until the fault condition no longer exists (and in some cases a minimum off-time is satisfied), or a **LOCKOUT**. A **LOCKOUT** is a condition whereby the compressor will remain off until the fault condition no longer exists AND the manual reset button is pushed (or power to the control module is cycled). Lockouts may also be reset from the E2 or remotely through Site Manager, including oil pressure if remote re-set has been enabled for this fault (this is password protected). A **WARNING** is a fault that doesn't keep the compressor from running (an example is an open or shorted unloader coil).

The following compressor protection features are provided on all Copeland Discus compressors with CoreSense Diagnostics:

- High discharge pressure
- Low suction pressure
- Discharge temperature
- Line-break motor protection (2D / 3D)
- Motor temperature protection (CoreSense Diagnostics replaces the solid-state module used on 4D / 6D compressors)
- Low voltage
- Power interrupt motor protection
- Welded contactor protection
- Loss of phase motor protection
- Low oil pressure (CoreSense Diagnostics replaces the Copeland™ brand Sentronic+™ oil pressure protection modules).
- Part winding start failure
- Locked rotor and settable MCC protection
- Shorted unloader coil protection
- Shorted contactor or pilot relay coil protection

The following options are available with Copeland Discus compressors with CoreSense Diagnostics:

- Crank case heater control
- Blocked suction modulation (4D/6D compressors)
- Discus Digital™ capacity modulation (3D/4D/ 6D)

Note: The conventional blocked suction or Moduload valving MAY NOT be activated to perform in a digital fashion. These valve mechanisms have not been designed to work reliably in a digital fashion. Only use this feature with Discus Digital™ modulation hardware.

1.2.2 Remote Reset

The oil pressure lockout may be reset through the E2 or remotely through Site Manager if the reset option is enabled.

The service contractor and end user policies need to be considered when deciding whether to enable or disable the oil pressure remote reset feature. The default condition is to “disable” this feature.

Refer to **Section 4, Figure 4.15** for enabling or disabling this remote reset.

1.2.3 Failsafe Operation

The **FAILSAFE** mode may be configured at any time by setting the #10 dipswitch to the “on” or “off” position as desired. The failsafe condition is acted upon by the compressor in the event that communication is lost for 5 or more minutes. Upon the re-establishment of communication to the rack controller the run command from the rack controller overrides the failsafe command.

The failsafe switch position may be changed at anytime. However, the module must be reset before the control module recognizes a change in the switch position.

When the compressor is running in the failsafe “on” position, all of the compressor protection features are enabled with the exception of welded contactor.

There are different philosophies regarding the failsafe settings. One suggestion is to observe the typical “percent of full load capacity” required to satisfy demand (this is perhaps seasonal). Setting the switches to provide this capacity (with perhaps a little reserve) is one approach.

As with all dipswitch positions, a legend may be found inside the lower cover of the control module that explains the switch positions.

1.2.4 Welded Contactor Protection

Voltage is sensed at the motor terminals of the Copeland Discus compressor with CoreSense Diagnostics. If voltage is present after the contactor has been signaled to “open”, the module will send a welded contactor alarm to the E2. The E2 then issues a run command to the module to load the contactor, bringing all three legs of the power supply to the compressor back on line. This prevents a single-phase motor burn. The compressor will run continuously until the unit is manually shut down or the alarm is cleared in the E2. Safety devices (pressure switches and motor protection) will attempt to override this feature.

This is not to be confused with single-phase protection at start-up or while running. In that case, the contactor will be instructed to “open”, shutting down the compressor.

1.2.5 Crank Case Heater (CCH) Control

The sensor module contains an on-board CCH control relay. An auxiliary contactor is no longer required to turn the heater on when the compressor turns off.

The appropriate voltage supply to the CCH power input terminals (115 V / 230 V) is required.

1.2.6 Start-up Delay Feature

To reduce the sudden in-rush of power associated with multiple compressors starting at one time, compressor start-ups are staggered slightly at the end of the anti-short cycle delay. The delay is equal to 100 milliseconds x node number. Therefore node number 4 will start 0.3 seconds after node number 1. Refer to the status code table to see which events trigger an anti-short cycle delay.

1.2.7 “Jog” Feature

The reset button on the front of the control module may be used as an emergency shutdown, such as for clearing liquid during a start-up. After the module re-boots (approximately 30 seconds) the compressor will run again. The reset button may be pushed as necessary to stop the compressor.

1.2.8 Dipswitch Settings

Dipswitch selection for the address, baud rate, parity, operating and failsafe mode selection simplify service and start-up procedures. At initial power-up or after pushing the Reset button, the following information will be displayed on the LCD:

Control Module Firmware Version	
Sensor Module Firmware Version	
Node Address	
Baud Rate	(9600 or 19200)
Parity	(Parity or No Parity)
Mode	(Network or Stand-Alone)
Failsafe	(ON or OFF)

1.3 Modulation Control

CoreSense Diagnostics v2.11 can control blocked suction (conventional unloading) valves or Digital unloading valves without separate relay outputs or the need for an IDCM module. Demand from the rack controller to the unloader valve is through the RS 485 communication network and the actual on/off control is facilitated by the control module.

Digital modulation will be available for the 3D, 4D and 6D compressor. The E2 can control any combination of compressors, blocked suction compressors and/or digital compressors. When more than one digital compressor is in a suction group, only one compressor at any given time will be operating in a “digital” mode (i.e. modulating in a pulse-width fashion).

Blocked suction (and Moduload) compressors are set up in the suction group as stages (i.e. the compressor is one stage and each unloader is one stage). The total output of the compressor (horsepower or capacity) is the sum output of each individual stage. When an unloader stage is “on” it is producing capacity (this is when the solenoid is de-activated, or “off”). If you override an unloader stage “off”, the solenoid is energized.

When setting up the suction group using Digital compressors, the compressor is one stage (regardless of the number of unloaders). A 3D Digital, 4D Digital, 6D Digital with one unloader or a 6D Digital with 2 unloaders are all configured as one stage.

The digital control cycle is by default a 20 second period. Within this period the output of the compressor will be pulsed to produce (on average) the capacity requested by the controller. The advantages of Digital control are significant:

- Dramatically reduced compressor contactor cycling
- Tighter control of pressure or temperature
- Reduced set-point error

Refer to **Figure 1.2** for a comparison between the modulation control requirements with and without CoreSense Diagnostics v2.11. The conventional control arrangement that is depicted shows a compressor without modulation, a compressor with conventional blocked suction modulation and one with Digital modulation.

1.4 Application Restrictions

Variable Speed – CoreSense Diagnostics v2.11 is not approved for use with variable speed drives. Other devices on the rack may use variable speed, but the compressor itself may not be modulated with an inverter.

Demand Cooling – The Copeland Discus compressor with CoreSense Diagnostics is equipped with Demand Cooling capability, and as such may be used as an R407A / R407C low temperature compressor.

For proper Demand Cooling control, the following firmware versions are required: control module - 1.30F05 or later, sensor module - 2.00F03 or later.

Low Temperature Operation – The CoreSense Diagnostics electronics are designed to operate between -25°F and 150°F. At temperatures below 0°F the LCD display may be “slow”, but the compressor status information in the E2 is up-to-date.

2.0 Installation Instructions

Emerson Climate Technologies requires that all customers review the recommended guidelines in the published Application Engineering Bulletins, and ensure that best engineering practices are followed in the use of Copeland™ compressors. Emerson Application Engineering Bulletins can be found on our website, www.EmersonClimate.com under the section titled “Online Product Information.” The advice and conclusion by Emerson represents our best judgment under the circumstances, but such advice given and/or conclusion made, or results obtained shall be deemed used at your sole risk.

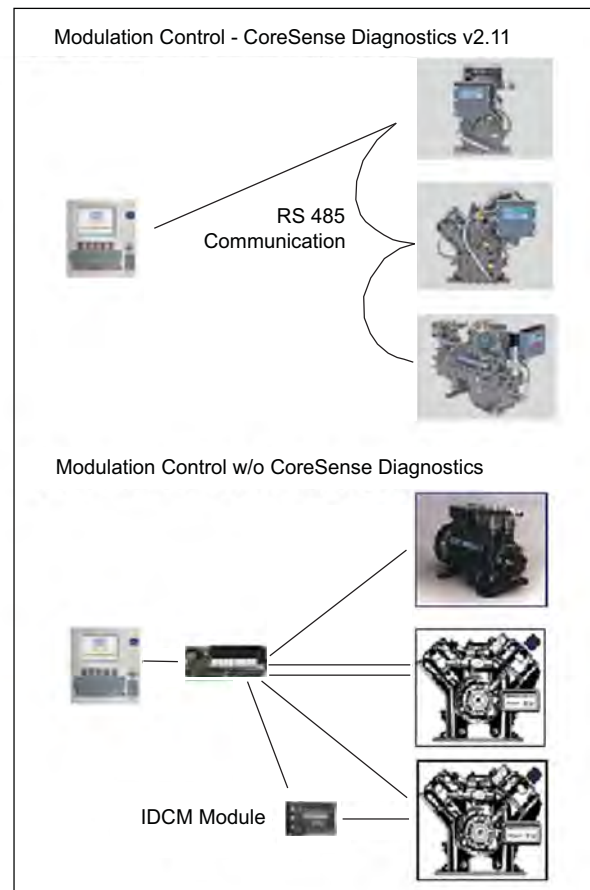

Figure 1.2 – Modulation Control

2.1 Mounting and Installation

The Copeland Discus compressor with CoreSense Diagnostics is designed and engineered for use in a supermarket rack application. Its environmental restrictions are not different than other Copeland Discus™ compressors. As such, the compressor must be in an equipment room, rack house or roof enclosure to prevent direct precipitation on the compressor. The following clearance provisions must be considered when designing the rack for use with a Copeland Discus compressor with CoreSense Diagnostics:

- Removal of the lower cover of the control module for access to dip-switches and the communication network connector
- Removal of the control module for service reasons
- Removal of the pressure switch cover (2D / 3D) for service reasons
- Removal of the harness cover shroud (4D / 6D)
- Removal of terminal box lids for service reasons

Refer to customer drawings in **Appendix F** for dimensional envelopes of CoreSense Diagnostics.

2.2 Terminal Box Connections

Feature	Electrical Requirements
CoreSense Diagnostics Supply Voltage (Module Power)	24 volts AC Class II power supply
Pilot Circuit Voltage (Contactor Output)	24 volts AC (supplied by CoreSense Diagnostics v2.11 to the pilot relay, or contactor)
Crank Case Heater voltage supply	115/208/230 per customer specification
Compressor Motor	Model Dependent
Head Fan	Per OEM Wiring

The following terminal box connections must be made by the original equipment manufacturer:

- Module power – 24 volts AC supplied by a Class II power supply. This powers the electronics, unloaders, crank case heater relay, and contactor output (to load the pilot relay or contactor). **Use AMP terminals (2x) 520184-2**
- Contactor – Output connections to the contactor pilot relay or contactor coil. **Use AMP terminals (2x) 520183-2 or 520184-2**
- Crank case heater power supply – 115vac or 208/230vac. A switching relay inside the sensor module controls the crank case heater. An

auxiliary contact on the contactor is not required. **Use AMP terminals (2x) 520194-2**

- Copeland Discus compressor with CoreSense Diagnostics use the same motor terminal connections.

While the Copeland Discus compressor with CoreSense Diagnostics is primarily intended for use in supermarket rack applications, **it is possible to utilize this technology in other applications without a communication network.** Configuring the dipswitch settings to the “stand alone” position allows the compressor and unloaders to be controlled by a 24 volt signal to input leads in the terminal box. Protection, control and diagnostic features are still functioning while in the stand-alone control mode.

Inherent in the functionality of the control module is short-circuit protection for the following circuits: Unloader coil operation and contactor output. **Additional electrical requirements and specifications (such as transformer selection) are provided in Appendix C.**

Refer to **Figure 2.1** for terminal box connection locations.

2.2.1 Current Sensing Module

All Copeland Discus compressors with CoreSense Diagnostics use a current sensing module in the terminal box. One of the motor power leads passes through the “toroid” (current sensor). Information from the current sensor is used to determine running amps, power consumption and locked rotor conditions.

There are 3 voltage sensing leads attached to the motor terminals and connected to the sensor module. Two of the leads are white, and one is black. **For proper calculation of power factor and motor power it is necessary for the black voltage sensing lead and the power lead through the current sensor to be connected to the same motor terminal.**

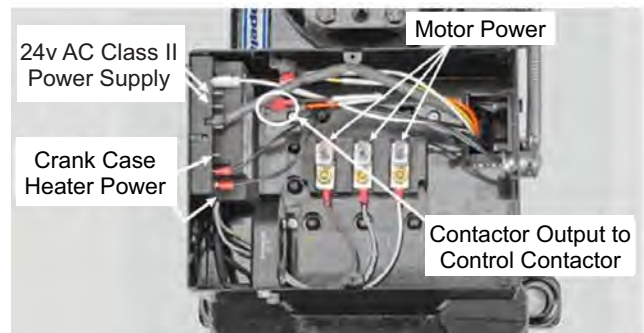

Figure 2.1 – Terminal Box Connections

Refer to **Figure 2.2** for sensor module lead connections.

2.2.2 Fan Connections

- Copeland Discus compressors with CoreSense Diagnostics are not shipped from the factory with fans installed. OEM installation of fans should follow established regulatory, OEM engineering and end user specifications regarding wiring.
- Head fan requirements for these compressors are identical to other Discus compressors. Refer to **Application Engineering Bulletin AE4-1135**.

2.3 Controller Requirements

The control network utilizes an open MODBUS protocol. Rack controller manufacturers may develop equipment to interface with and control Copeland Discus compressors with CoreSense Diagnostics. For Non-Emerson Retail Solutions products, consult with the controller manufacturer regarding controller compatibility with CoreSense Diagnostics v2.11.

For the Emerson Retail Solutions E2 controller, it must be equipped with an Emerson Retail Solutions CoreSense Diagnostics Network Interface Board (Emerson Retail Solutions part number 637-4890). **The controller firmware must be revision level 2.60F01 or higher.**

Refer to Emerson Retail Solutions E2 RX Refrigeration Controller manual 026-1610 for detailed information

regarding the CoreSense Diagnostics compatible rack controller.

2.4 Communications Network

The CoreSense Diagnostics module and rack controller communicate with each other using MODBUS communications protocol. The wiring network uses RS485 hardware connections at each node. The CoreSense Diagnostics communication cable terminates in the rack controller at an interface card and is routed to each compressor in a daisy-chain format. Refer to **Figures 2.5, 2.6 and 2.7**.

One E2 controller can control two racks. One daisy chain may be used for 2 racks, but two RS-485 connections are available on the Network Interface Board if two parallel daisy-chains are preferred. The CoreSense Diagnostics Network Interface Board is shown on **Figure 2.6**

One E2 controller can control 4 suction groups, with up to 16 stages in each suction group.

2.5 Network Terminations and Cable Routing

Each compressor (network node) has a jumper that must be positioned to define whether or not the node is in the middle or end of the daisy-chain. The last compressor in the daisy-chain is “terminated” and the jumpers must be set accordingly. The E2 jumpers on the Network Interface Board are always set for

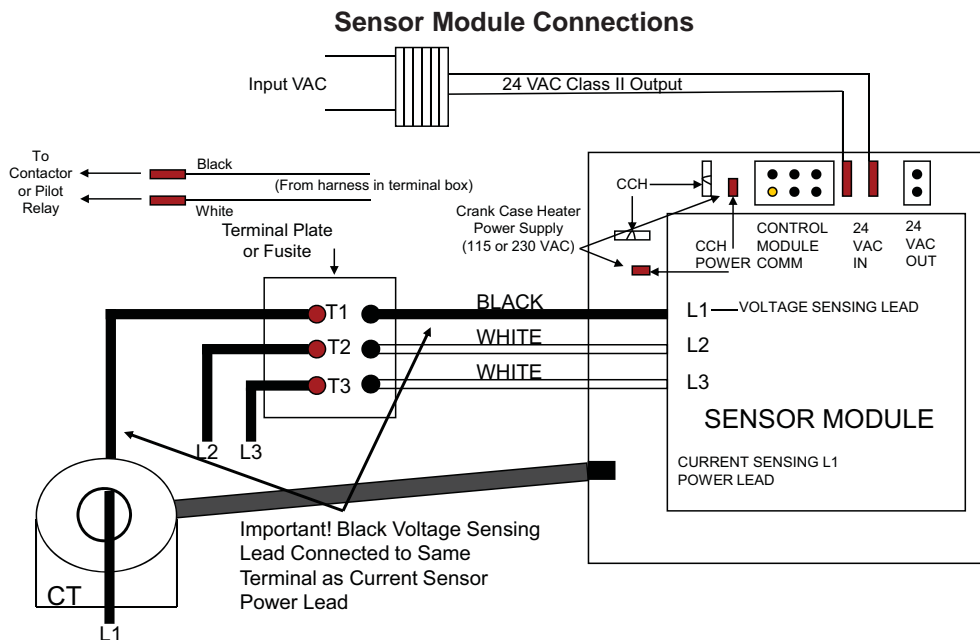

Figure 2.2
Sensor Module Wiring

“terminated” (refer to **Figure 2.6**).

The communications wire to the compressor may be routed into the rear of the side conduit (2D / 3D) and along the channel which leads into the control module. The 4D and 6D wire routing can be alongside the wire harness and into the control module.

Appropriate use of strain reliefs will prevent damage to the circuit board connector in the event of an accidental mechanical load to the communication wire. Note that the rear of the 2D / 3D conduit contains a tie-wrap feature for anchoring the communication wire. Refer to **Figure 2.9** for photos of wire routing.

Important ! Note that the RS485 is polarity sensitive. “Pos” wires must connect to other “Pos” terminals, and “Neg” wires must connect to other “Neg” terminals. The shield wire is connected to the center terminal, or “0 volt” position. Refer to **Section 6.15** for voltage specifications and troubleshooting.

2.5.1 RS485 Communication Wiring Types

A shielded, twisted pair cable such as Belden #8761 (22AWG) should be used for the communication wiring.

2.6 CoreSense Diagnostics v2.11 Service Instructions

Refer to **Sections 3, 4, 6** and **7** of this document for commissioning, service and troubleshooting instructions.

2.7 Compatibility of Service Compressors

The following S/Ns may be used to determine whether service compressors are compatible with CoreSense Diagnostics hardware and accessories:

2D built on or after	S/N 04D
3D built on or after	S/N 04D
4D built on or after	S/N 05D
6D built on or after	S/N 05D

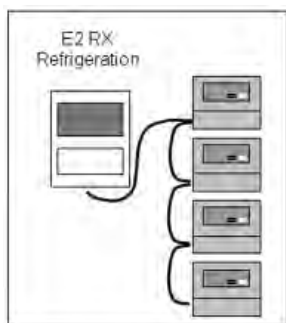

Figure 2.5
RS-485 Daisy-Chain Configuration



Figure 2.6
CoreSense Diagnostics Network Interface Board

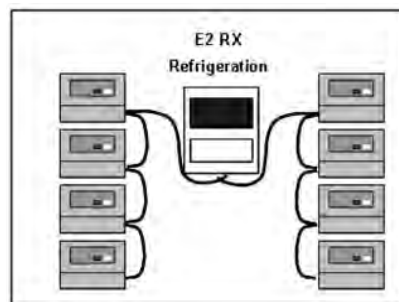

Figure 2.7
Two Rack Daisy-Chain

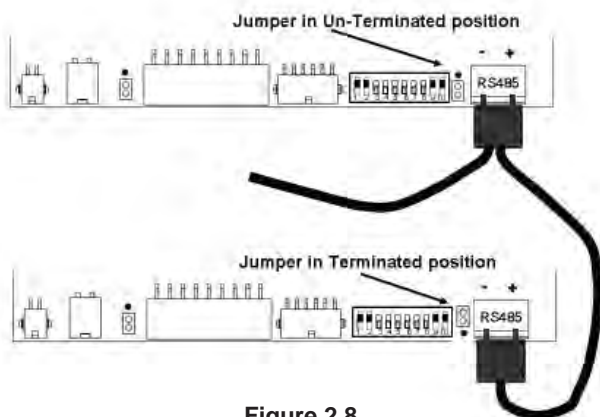

Figure 2.8
Communication Wiring and Jumper Positions



Figure 2.9
2D / 3D Communication Wire Routing

2.8 CoreSense Diagnostics v2.11 Model Numbers

Factory built Discus compressors with an S/E (the last 3 digits in the model number) beginning with "A" are Copeland Discus compressors with CoreSense Diagnostics. Models with an S/E that begins with "AD" are equipped with Demand Cooling. The remaining numbers define the service valve configuration as well as crankcase heater presence.

3.0 CoreSense Diagnostics v2.11 Quick Start Guide

1) Module Power

Apply power to the CoreSense Diagnostics v2.11 sensor modules located in the compressor terminal box. Power requirements for the CoreSense Diagnostics v2.11 modules is a 24VAC supply provided by a class II transformer. For additional information on transformer selection including VA requirements refer to **Appendix C** of this document.

2) Communication Wiring

Connect the CoreSense Diagnostics v2.11 control modules to the rack controller by configuring the RS-485 communications network. The communication cable terminates in the rack controller on the Network Interface Board, and is routed to each of the compressors in a daisy-chain format. For communications to function properly the termination jumpers at the rack controller and each module should be set according to their position in the chain. The end devices (including the rack controller) should be set to the terminated position. The devices in the middle of the chain should be set to unterminated. The CoreSense Diagnostics v2.11 control modules have the ability to communicate to E2 or non-E2 rack

controllers. Set the controller jumper accordingly. Refer to **Figure 3.0** below to locate the position of the termination and controller jumpers on each control module. For a complete description of the communications network refer to **Section 2.4**. For details on troubleshooting problems with the communications network refer to **Section 6.15**.

3) Verify DIP-Switch Settings

CoreSense Diagnostics v2.11 devices are equipped with a DIP switch to set the node address. In addition, this DIP switch determines the baud rate, parity, control mode, and failsafe settings of the module. Refer to **Figure 3.0** below for details:

4.0 CoreSense Diagnostics v2.11 Commissioning Procedure

As with other devices, the CoreSense Diagnostics v2.11 modules must first be commissioned to establish communications with the rack controller. During the commissioning process the E2 will recognize the CoreSense Diagnostics v2.11 modules in order as designated by the node address settings on the module DIP switches.

Important Note: The following commissioning instructions pertain to E2 controllers with version 3.02F01 or later firmware. If you have an earlier version of firmware we recommend that you upgrade to the latest version available.

To determine the firmware revision level in the E2 follow these steps:

1. From the main menu select 7 (System Configuration)
2. Press 3 (System Information)
3. Press 4 (Firmware Revision)

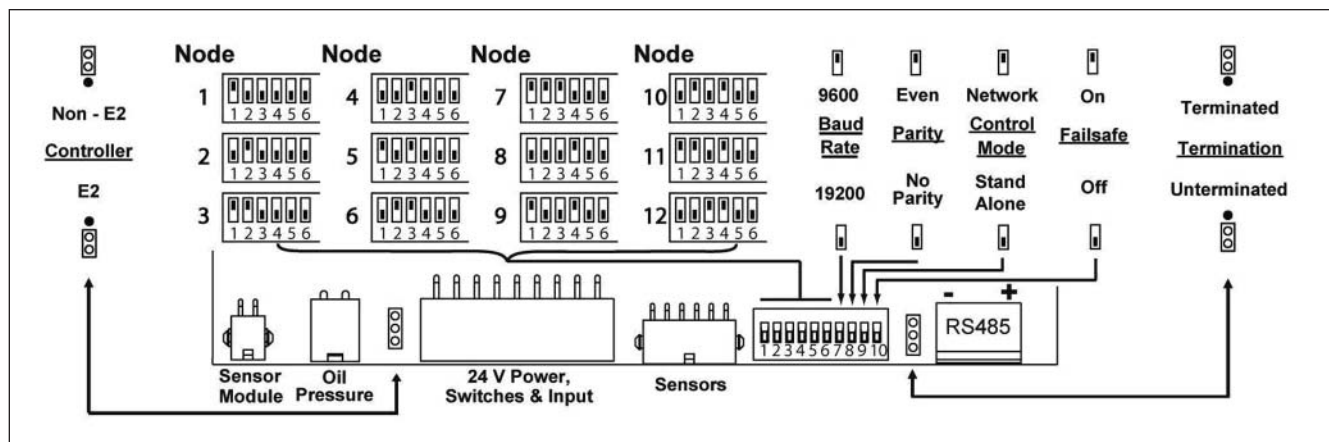

Figure 3.0 – Control Module Instruction Label

The E2 should look like **Figure 4.1**.

4.1 Dip Switch Configuration

CoreSense Diagnostics v2.11 devices are equipped with a DIP switch to set their node address. In addition, this DIP switch determines the baud rate, parity, control mode, and failsafe settings of the module. Refer to **Figure 4.2** below for details:

To ensure proper communications, follow these steps:

1. Each CoreSense Diagnostics device that is connected to a rack controller should have a unique node address (as determined by the DIP switch settings).
2. The communications jumper should be set for E2 communication if connected to an E2 rack controller.
3. The last CoreSense Diagnostics device in the



Figure 4.1 - Firmware Revision

daisy-chain should have the communication jumper in the “terminated” position. In addition, the E2 should have the communication jumpers in the “terminated” position.

4. The parity for each of the CoreSense Diagnostics devices should be set to none. This can be accomplished by setting DIP switch number 8 to the down position.
5. The baud rate for each of the CoreSense Diagnostics devices should be set according to the rack controller. To determine the baud rate in the E2, follow these steps:
 - a. From the main menu select 7 (System Configuration)
 - b. Press 3 (System Information)
 - c. Press 1 (General Controller Info)
 - d. Access the Serial Communications Tab by pressing CTRL + 3
 - e. Use the Page Down button or scroll down to view the MODBUS communication settings.

Note: The default location for CoreSense diagnostic modules is the COM4 port, but there may be multiple MODBUS networks running on one E2. Be sure to select the proper network.

The E2 should look like **Figure 4.3** (following page).

Be sure that the DIP switch settings on each module for the CoreSense Diagnostics devices match the settings for the MODBUS network.

4.2 Network Setup

Once the DIP switch settings have been verified for each CoreSense Diagnostics module, you will need to establish communications with the new devices. Begin

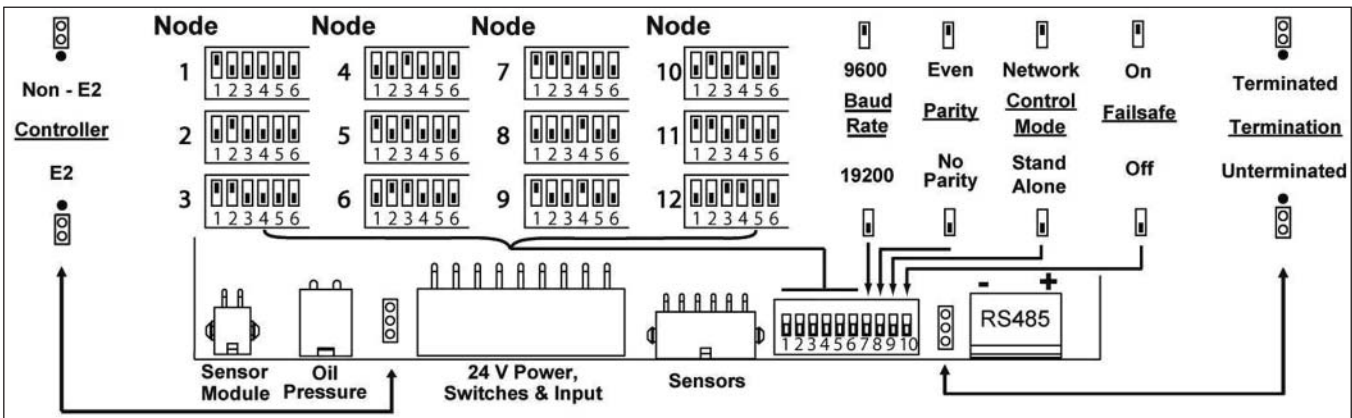

Figure 4.2 - Control Module Instruction Label

the network setup by following these steps:

1. From the main menu select 7 (System Configuration)
2. Press 7 (Network Setup)
3. Press 2 (Connected I/O Boards and Controllers)
4. Press Ctrl + 3 (ECT Tab)

The E2 should look like the Figure 4.4.

Enter the number of CoreSense Diagnostics devices under ISD-2.0.

To establish communications with the new devices follow these steps:

1. From the main menu select 7 (System Configuration)

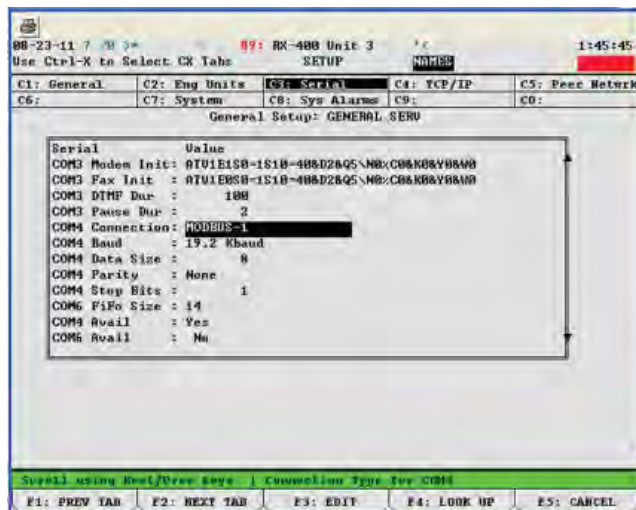

Figure 4.3 – Serial Communications Setup Screen

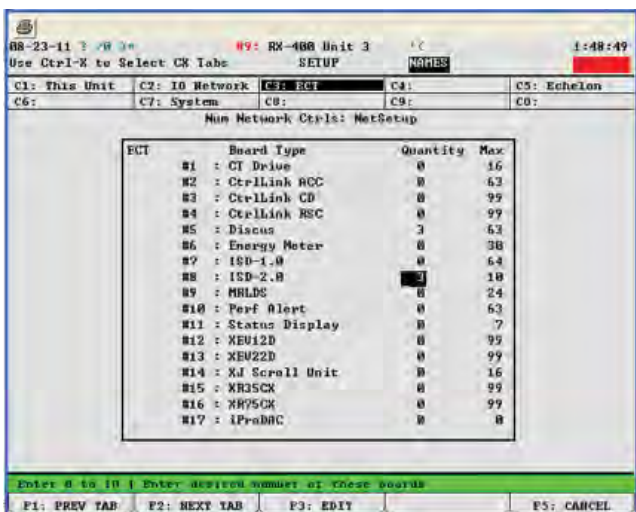

Figure 4.4 – Connected I/O Devices Screen

2. Press 7 (Network Setup)
3. Press 1 (Network Summary)

The E2 should look like **Figure 4.5**

4. Highlight the appropriate CoreSense Diagnostics device and press F4: Commission
5. Select the desired address and press Enter. Verify the address and press Enter again.
6. Repeat this process for each device.

Once a device has been successfully commissioned, the firmware version will be displayed and the status will be shown as online (**Figure 4.6**)

4.3 Enhanced Suction Group Setup

In order for the E2 to control compressor operation the proper input and output values must be entered into the system. This is accomplished by creating a suction group application in the rack controller. Programming of the suction group will depend upon the system as well as the options desired by the end user. The following section covers the steps necessary to setup the sample rack shown in **Figure 4.8**.

From the Main Menu:

1. Press 6 (Add/Delete Application)
2. Press 1 (Add Application)
3. Press F4 (Lookup) and select Enhanced Suction Group from the option list.
4. Enter the number of suction groups controlled by this E2.
5. When prompted by the E2 to edit the application, Press Y for yes.

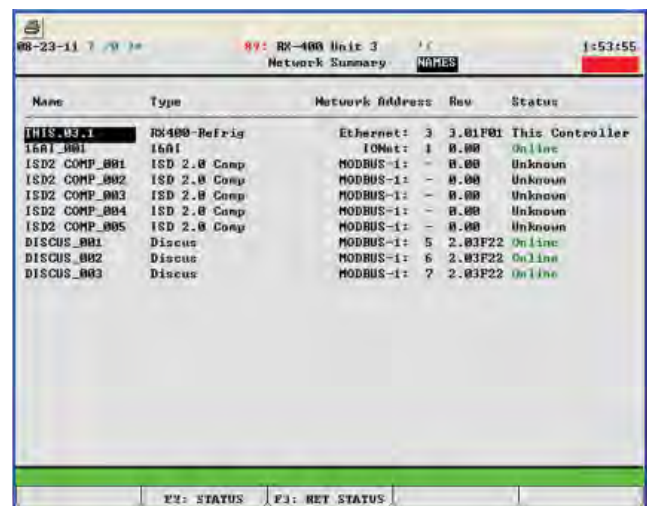

Figure 4.5 – Network Summary Screen

This will open the suction group setup screen as shown below in **Figure 4.7**.

From this screen you can edit the name of the suction group, select the control type, and enter the number of stages. The number of stages can be determined as follows:

- A standard compressor (no unloader) will count as one stage.

- A compressor equipped with digital unloading will count as one stage.
- A compressor with one bank of standard unloading will count as two stages.
- A compressor with two banks of standard unloading (6D only) will count as three stages.

To continue the suction group setup process:

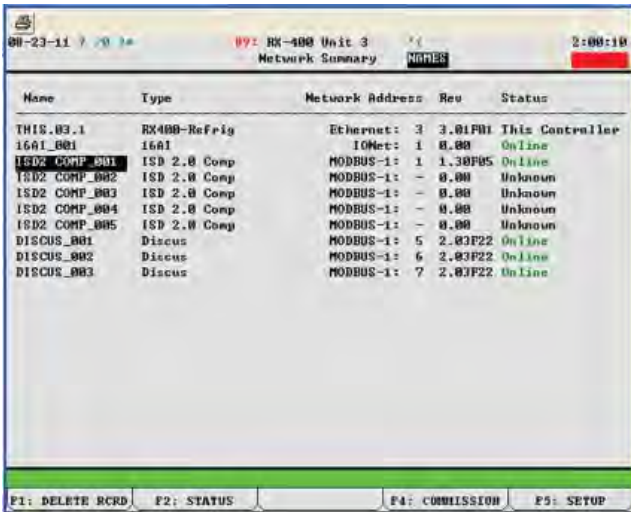

Figure 4.6 - Network Summary Screen

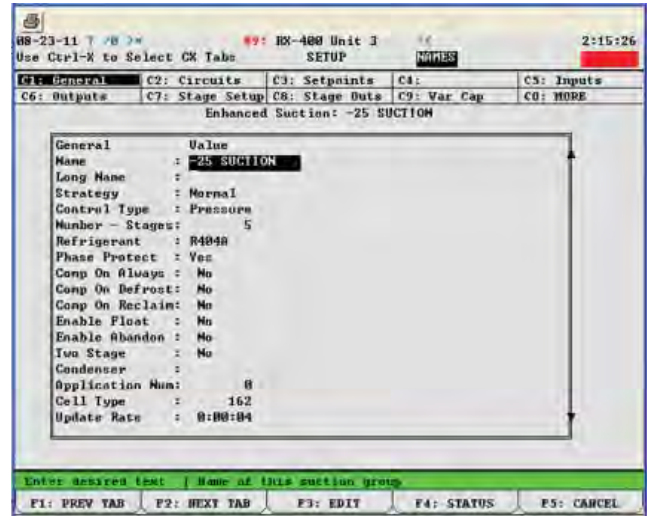

Figure 4.7- Enhanced Suction General Setup Screen

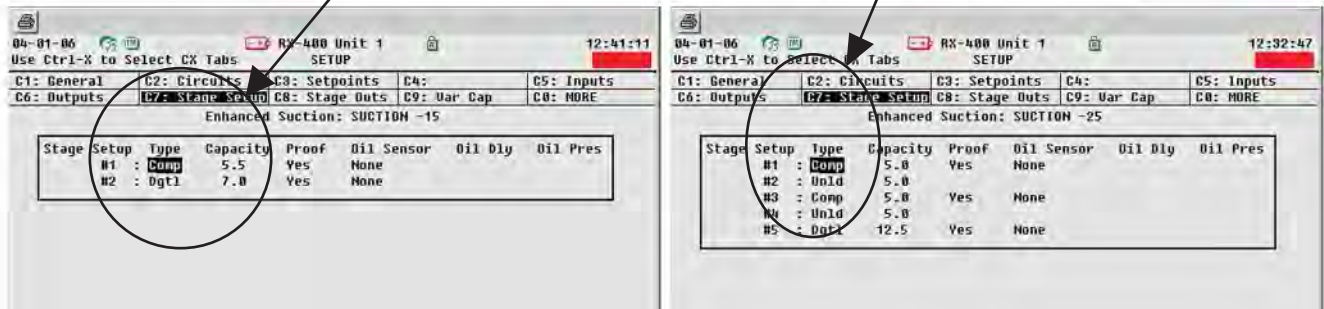
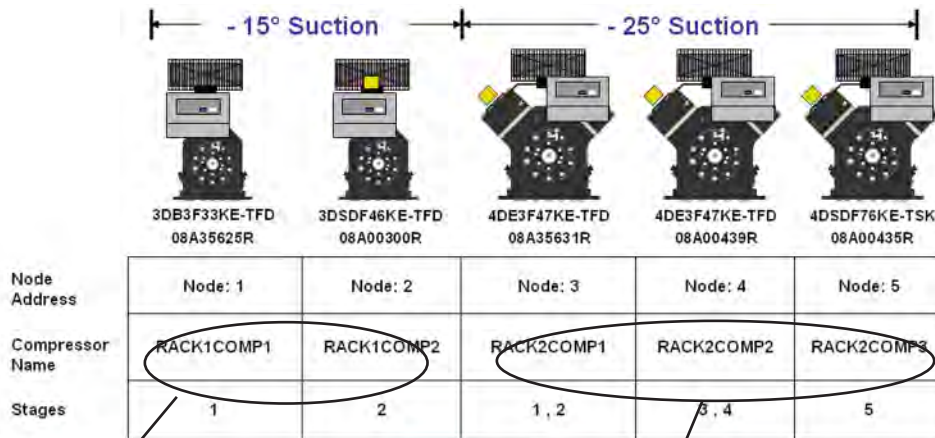

Figure 4.8 - Enhanced Suction Stage Setup Screen(s)

1. Press F2 (Next Tab) until the Stage Setup screen is displayed.
2. Under Type, select Comp for compressor, Unld for unloader, or Dgtl for digital.
3. Under Capacity, enter the compressor capacity in BTU/hr or the compressor horsepower for each stage. The E2 will use this value as the expected output for each stage and will cycle the stages according to the required demand.

Note: For a compressor equipped with an unloader (blocked suction or Moduload, but NOT digital) the horsepower should be divided between the compressor and unloader stages. A compressor with an unloader can be considered to be two different compressors from a control standpoint. When the suction group status screen shows the unloader to be “OFF” and the comp (compressor) to be “ON”, the compressor is running “unloaded”, i.e. the unloaded portion of the compressor is not contributing to generation of capacity. If the comp and unloader are both “ON”, the compressor is running at full capacity.

When these steps have been completed, the compressor setup screen(s) should look like **Figure 4.8**.

4.4 Associations

In order to provide compressor control, each CoreSense Diagnostics device must be associated with its appropriate suction group. To make these associations, follow these steps:

1. From the main menu select 7 (System Configuration)
2. Press 7 (Network Setup)
3. Press 4 (Controller Associations)
4. Press 4 (Compressor)

The E2 should look like **Figure 4.9**.

Enter the appropriate stage numbers. The example in **Figure 4.9** shows five compressors with a selection of standard, blocked suction and digital unloading.

4.5 Proofing

Also located on the Compressor Association Screen are the settings for compressor proofing. Proofing verifies that the compressors are turning ON and OFF as commanded by the suction group requirements. With proofing enabled the rack controller compares the digital command sent to the CoreSense Diagnostics module with a digital output from the module. If the

two values are not equal for an amount of time longer than the programmed proof delay, the rack controller will display a Proof Fail condition for that module. The rack controller will deactivate the Proof Fail once the module proofing output matches the command from the E2.

To configure proofing simply highlight the appropriate cell under the Proof column. Use the Previous/Next buttons on the E2 to toggle between the YES and NO settings. The rack controller will make the necessary associations between the module and suction group.

4.6 Failsafe

The compressor failsafe mode may be configured by setting the number 10 DIP switch located on each CoreSense Diagnostics control module. With the switch in the up position the compressor will be set for failsafe ON in the event that communications with the rack controller is lost for 5 or more minutes. If the switch is in the down position the compressor will be set for failsafe OFF. **Keep in mind that once a DIP switch setting is changed, a reset of the control module is required for the control module to recognize the change.**

The default setting for all Copeland Discus compressors with CoreSense Diagnostics leaving the factory is failsafe “ON”. If the rack has not yet been commissioned, system charging may be accomplished by supplying pilot circuit power to the compressor with the rack controller OFF. After 5 minutes the CoreSense Diagnostics module will send a run command to the contactor/pilot relay. Compressors with power to the contactors will then RUN with protection features in place (e.g. suction and discharge pressure, discharge temperature, motor protection).



Compressor	Suction Group	Stage			Proof
		Comp	Unld1	Unld2	
DISCUS_001		0	0	0	YES
DISCUS_002		0	0	0	YES
DISCUS_003		0	0	0	YES
ISD2 COMP_001	-15 SUCTION	0	1	0	YES
ISD2 COMP_002	-15 SUCTION	0	2	0	YES
ISD2 COMP_003	-25 SUCTION	0	1	2	YES
ISD2 COMP_004	-25 SUCTION	0	3	4	YES
ISD2 COMP_005	-25 SUCTION	0	5	0	YES

Figure 4.9
Compressor Association Screen

While running in failsafe mode the compressor will continue to run until either a fault occurs or until communications is re-established with the rack controller. This is to say that the only system controls in place to cycle the compressor are the high and low pressure safety controls. The trip/reset values for the high and low pressure controls are 360/250psi and 3/10psi (-2/8psi for R407A and R407C compressors) respectively. While it is not recommended to run the compressors in failsafe mode for long periods, it may be desirable to use adjustable low pressure cutouts to stage the compressors. This will allow for finer compressor control over the fixed value switch. To apply an adjustable pressure cutout you may simply wire it in place of the existing pressure switch.

4.7 CoreSense Diagnostics v.2.11 Setup Screens

The CoreSense Diagnostics module has many configurable settings that can be programmed through the E2.

Important Note: E2 firmware versions 3.02F01 and later have an improved offline programming feature. This feature ensures that modules retain the factory preset programming. In order to update the module configuration, follow these steps:

1. After navigating the setup screens and making the desired changes return to the CoreSense Diagnostics summary screen as shown in Figure 4.17.
2. Press Enter to reveal the device Actions Menu as shown in Figure 4.17b
3. Press 9 Application Commands. The E2 screen should look like Figure 4.17c

4. To program the module with changes made in the E2, press 2 Send E2 Cfg to Device. To verify module settings press 1 Send Device Cfg to E2.

To access the configuration screens for the CoreSense Diagnostics modules follow these steps:

1. From the main menu press 5 (Configured Applications)
2. Press 104 (ISD 2.0)
3. Highlight the desired device and press F5 (Setup)

The E2 screen should look like **Figure 4.10**.

On the General tab the device name is displayed. The default naming convention is shown as the device type (ISD2) followed by the device number (equal to the node address). If it is desired to have the device renamed in terms of the suction group for easier identification simply type over the default information using the E2 keypad. Note that the name is limited to 14 characters. If additional characters are needed, information may be entered in the cell next to Long Name.

To access additional configuration settings for the module Press Ctrl+2 to navigate to the Setup tab.

The E2 screen should look like **Figure 4.11**.

The parameters that can be set from this screen include:

- unloaders
- crankcase heater control
- anti-short cycle time
- maximum continuous current (MCC)
- compressor voltage
- compressor frequency

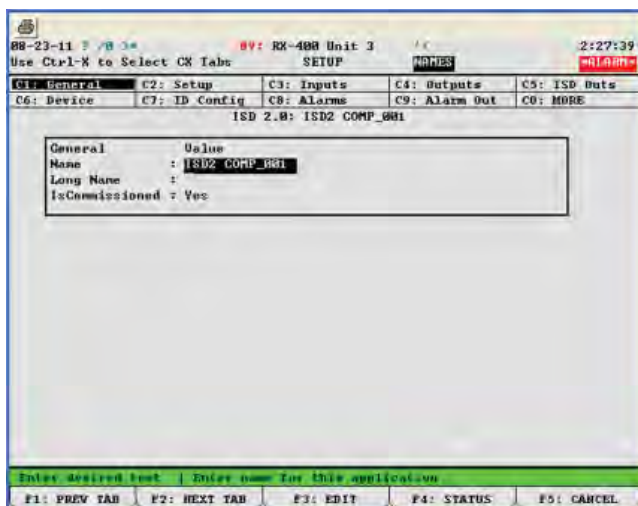

Figure 4.10 – ISD Setup Screen (General Tab)

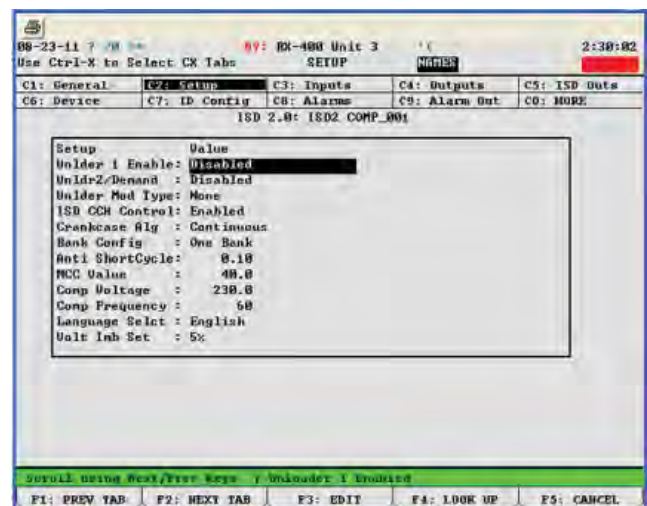

Figure 4.11 – ISD Setup Screen (Setup Tab)

language
voltage imbalance
demand cooling

4.8 Unloader Configuration

The unloader configuration settings are preloaded at the factory and will match the requirements of the compressor. The **Unloader Mod Type** setting of *Digital* is for **digital unloading only**. For compressors without unloaders or for those with non-digital unloading (blocked suction) the **Unloader Mod Type** should be set to *None*.

For proper operation when in the Digital Modulation mode, the number of banks (**Bank Config**) must be correct. 3D compressors have one bank, 4D compressors have two banks and 6D compressors have three banks.

If this configuration is changed in the field (for example to add Digital Modulation as a field upgrade), please follow these steps to configure the suction group and the compressor associations:

Amend the number of stages in the suction group if necessary (see section 4.3). Then, change the compressor associations as follows:

1. From the main menu select 7 (System Configuration)
2. Press 7 (Network Setup)
3. Press 4 (Controller Associations)
4. Press 4 (Compressor)

Referring to **Figure 4.9** (section 4.4), delete the suction group association and set the stages to “zero” for this compressor. Stair-step out. Next, re-enter the association screen and re-establish the suction group and the proper stage number. Note: for a digital compressor, the compressor (regardless of the number of unloaders) will be just one stage.

Re-establishing the association is done to allow the suction group to see that the compressor is now a Digital compressor (or is no longer a digital, as the case may be).

4.9 Demand Cooling Configuration

Demand Cooling configuration settings are preloaded at the factory and will match the requirements of the compressor. To verify the settings or to enable demand cooling follow these steps:

1. From the main menu select 5 (Configured Applications)
2. Press 104 (ISD 2.0)

3. Press F5 (Setup)
4. Press F2 (Next Tab)

The E2 screen should look like **Figure 4.11**

Demand Cooling control is provided by the Unloader 2 solenoid output. Setting the Unloader 2 value to Demand Cooling will allow the Demand Cooling valve to be cycled properly based on the compressor head temperature.

4.10 Crankcase Heater Control

The parameter labeled ISD CCH control determines whether the heater is to be controlled by the module or by an external means such as an auxiliary contact. Setting this value to “enabled” allows the heater to be controlled by the CoreSense Diagnostics module.

The parameter labeled Crankcase Algorithm determines how the CoreSense Diagnostics module will control the switching of the heater. With this parameter set to continuous, the heater will be activated any time that the compressor is OFF. This operation is the same as if the heater were controlled by a set of auxiliary contacts

4.11 Anti Short Cycle

The parameter labeled Anti Short Cycle determines the minimum off time for compressors before they restart. This value is set to reduce the number of start/stop cycles on the compressor. The default value is 0.1 minutes or 6 seconds. This value may be set from 0.1 to 2 minutes.

4.12 MCC Value

The parameter labeled MCC Value is the maximum continuous current for the compressor. This value is set to provide additional motor protection for the compressor. This value is programmed based upon the current requirements of each compressor model. (For dual voltage motors, the MCC value will be set to the 460 volt value. If the compressor is run at a different voltage the MCC value may be adjusted accordingly).

4.13 Compressor Voltage

The value for compressor voltage is preloaded at the factory. If the compressor is to be operated at a voltage other than the value listed, the proper voltage must be entered into this field.

4.14 Compressor Frequency

The value for compressor frequency is preloaded at the factory. If the compressor is to be operated at a frequency other than the value listed, the proper frequency must be entered into this field.

4.15 Language

The LCD display on the CoreSense Diagnostics control module can be set to display messages in multiple languages. The available options are English, Spanish, Portuguese, French and German.

4.16 Voltage Imbalance

The voltage imbalance setting determines the maximum percentage of voltage imbalance on the three compressor phases. If the measured voltage exceeds the imbalance setting, the module will alarm and shut down the compressor. The default setting for this parameter is 5%.

4.17 Inputs

The compressor input values for each module are

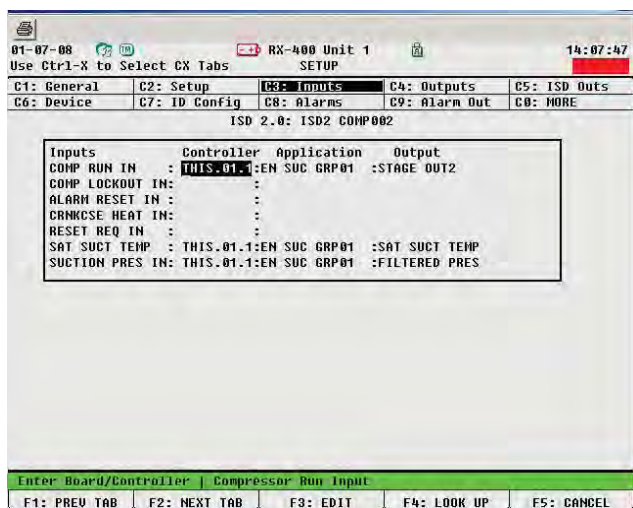

Figure 4.12 – ISD Setup Screen (Inputs Tab)

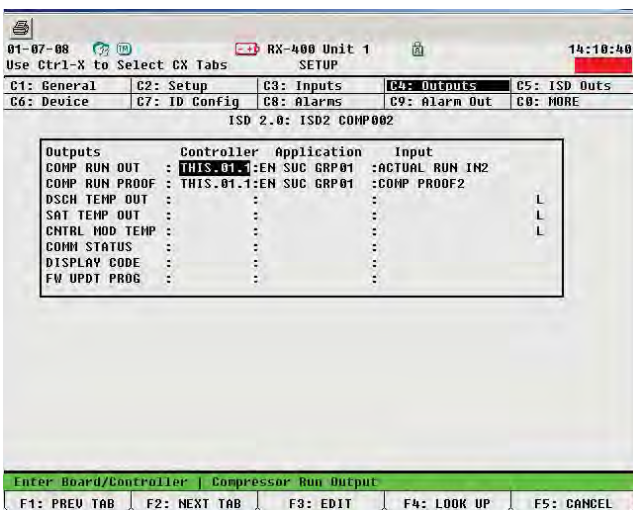

Figure 4.13 – ISD Setup Screen (Outputs Tab)

located on the Input tab. To navigate to this screen press Ctrl+3.

The E2 should look like **Figure 4.12**.

The input values as shown are automatically mapped by the E2 during the commissioning process. This takes place when the compressor associations are made. Refer to **Section 4.4** of this document for additional details concerning this process.

4.18 Outputs

Similarly, the compressor output values for each module are located on the Output tab. To navigate to this screen press Ctrl+4.

The E2 should look like **Figure 4.13**.

As with the input values, the output values as shown are automatically mapped by the E2 during the commissioning process. This takes place when the compressor associations are made. Refer to **Section 4.4** of this document for additional details concerning this process.

4.19 ID Configuration

The ID Config tab contains information about the compressor identification such as the model and serial number. To navigate to this screen press Ctrl+7.

The E2 should look like **Figure 4.14**.

It also contains additional fields for Customer ID, Customer Name, and Location. These fields are provided for the end user and are meant to be populated during the commissioning process. This identification information can be useful when performing remote compressor diagnostics.

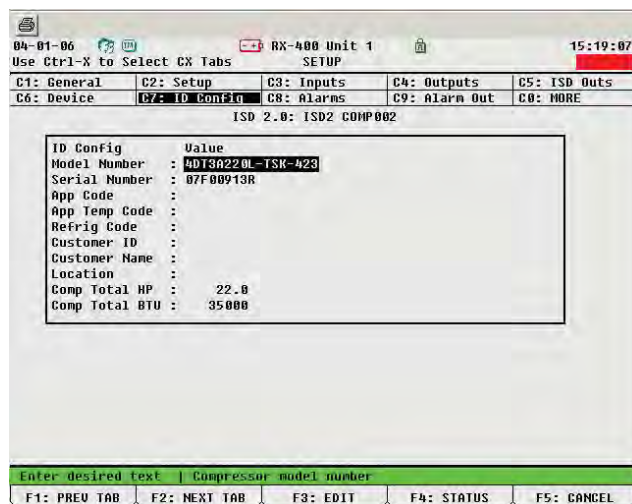

Figure 4.14 – ISD Setup Screen (ID Config Tab)

As with other alarms in the E2, the alarms associated with the Copeland Discus compressors with CoreSense Diagnostics can be programmed for different levels. To view the alarm settings navigate to the Alarms tab by pressing Ctrl+8.

The E2 screen should look like **Figure 4.15**.

Use the Previous/Next buttons on the E2 to scroll through the various settings of:

- Alarm
- Failure
- Notice
- Disabled

4.20 CoreSense Diagnostics v2.11 Navigation

To access information from the CoreSense Diagnostics

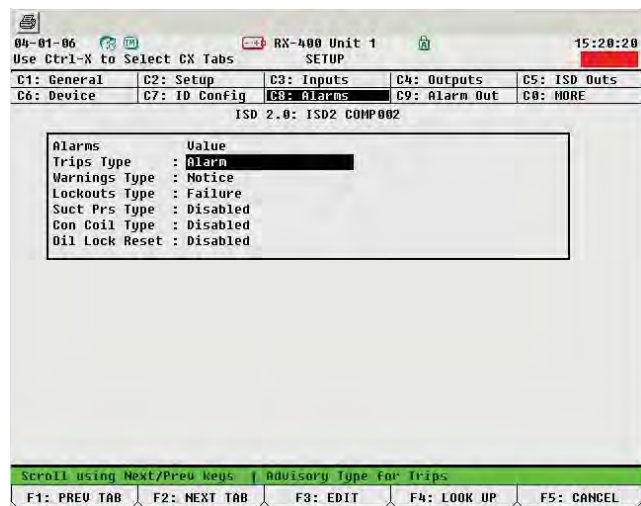

Figure 4.15 – ISD Setup Screen (Alarms Tab)

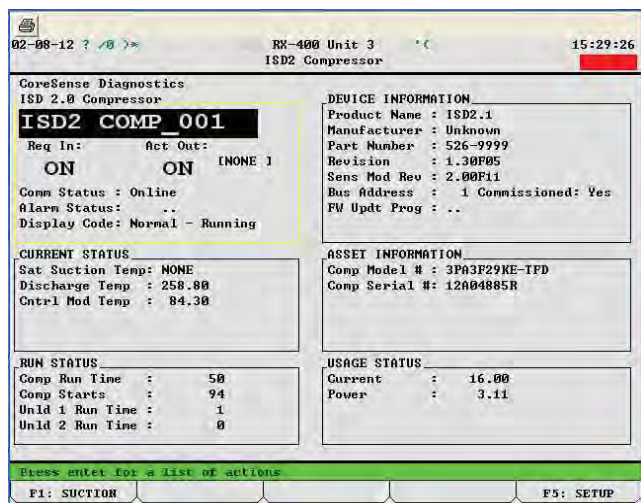

Figure 4.16 – ISD Summary Screen

modules using the E2 rack controller follow these steps:

1. From the main menu select 5 (Configured Applications)
2. Press 104 (ISD 2.0)

The E2 should look like **Figure 4.16**.

This screen provides a general summary of all CoreSense Diagnostics devices that are connected to the rack controller. It gives information on the run status as well as more detailed information such as the discharge temperature and current draw of each compressor. This screen also shows the status of the device such as whether it is online or alarming and if the device has been commissioned. To view additional information, select the desired device using the arrow key and press “Enter”.

The E2 screen should now look like **Figure 4.17**.

This screen provides additional compressor information such as the model and serial number. It also provides run history information such as compressor run time and the number of compressor starts. If the compressor is equipped with unloaders the unloader run time will also be displayed. For more detailed information about each compressor highlight the compressor name as shown on **Figure 4.17** and press Enter. Press 6 (Detailed Status).

There are many useful screens located in the detailed status area. To monitor the status of the compressor motor, navigate to the Windings tab by pressing Ctrl+5. The E2 screen should look like **Figure 4.19**.

This screen shows the current draw of the motor and

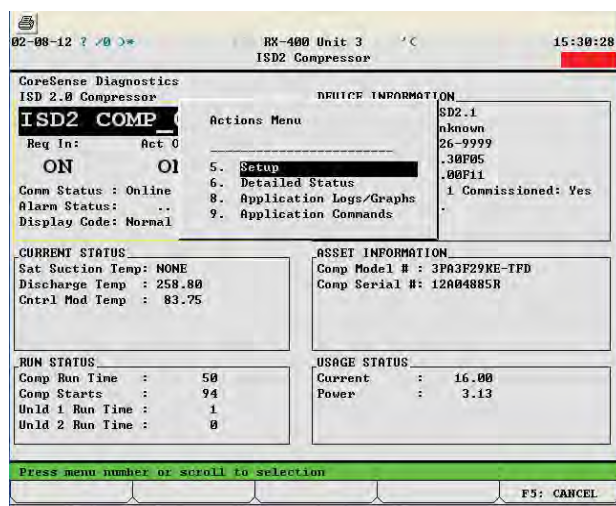

Figure 4.17 – Compressor Information Screen

the voltage at each compressor terminal. In addition, the starting current is shown as Locked Rtr Cur. (Note: This value is the first cycle peak current and will be slightly higher than the published steady state RMS locked rotor value). Power factor and power consumption are also listed.

For more information on the compressor run history navigate to the History tab by pressing Ctrl+6.

The E2 screen should look like **Figure 4.20**.

While basic compressor information such as run hours is listed on the ISD summary screen, the history screen includes additional information such as a short cycle counter and low oil run time. This information can be useful in diagnosing compressor issues.

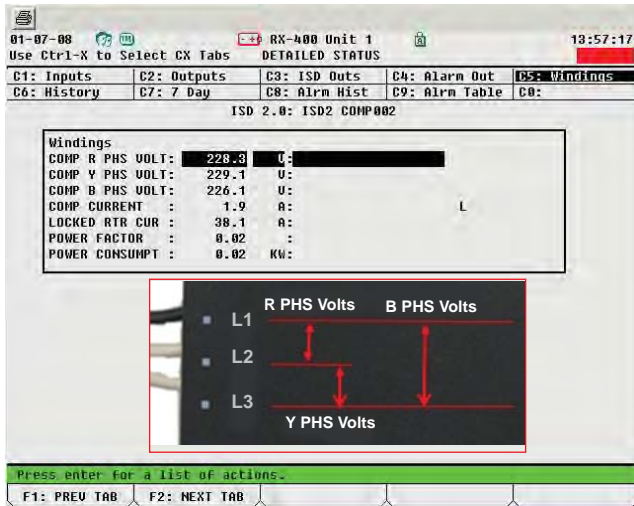

Figure 4.19 – Detailed Status Screen (Windings Tab)

In addition to compressor run history, the CoreSense Diagnostics v2.11 module also retains a history log of the most recent alarms. To access this information, press Ctrl+8.

The E2 screen should look like **Figure 4.21**.

The screen will display the last ten alarms that have occurred with alarm number one being the most recent. To determine the time at which a particular alarm has occurred, consult the E2 alarm screen which will display a time stamp of each event.

For a running count of all events and alarms related to CoreSense Diagnostics press Ctrl+9 to access the Alarm Table tab.

The E2 screen should look like **Figure 4.22**.

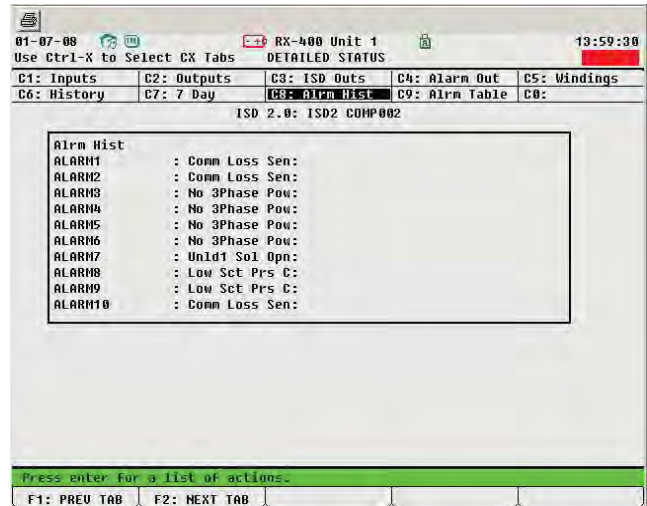

Figure 4.21 – Detailed Status Screen (Alarm History Tab)

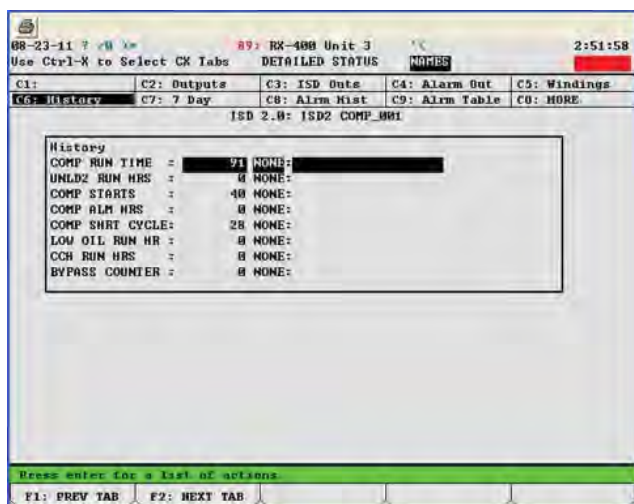
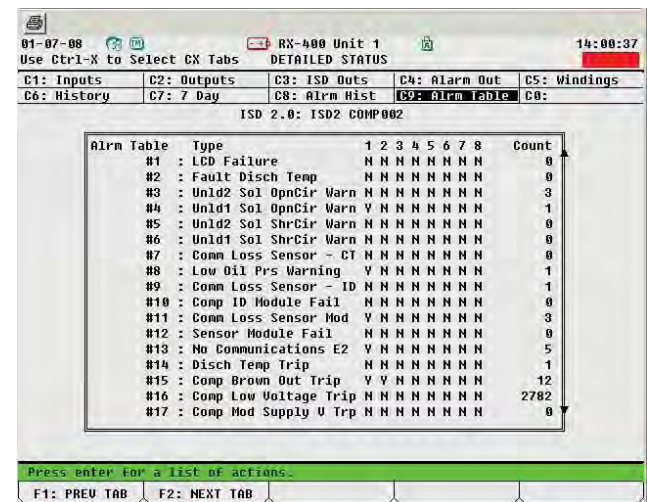

Figure 4.20 – Detailed Status Screen (History Tab)



**Figure 4.22
ISD Detailed Status Screen (Alarm Table Tab)**

The screen will display each of the related events in a table format with an indication of whether the event has occurred. The columns labeled 1 through 8 at the top represent days of the week with number 1 being the current day of operation. In addition, the count column serves as a running counter of each alarm since the device has been commissioned. In the event that a compressor needs to be replaced, this history information will be zeroed when a new control module is connected.

5.0 Stand-Alone Installation and Operation

A Stand-Alone control configuration has been established to allow control of the compressor contactor and unloader(s) in a condensing unit or other application when the network mode is not used. Control of the contactor and unloader is through a 24 volt AC signal supplied to spare leads inside the terminal box.

Please refer to **Figure 5.1** of the wiring diagram that shows the 24 volt power supply and the stand-alone input connections. It is important that the 24 volt signal to the input leads comes from the same leg of the transformer as the left-hand side sensor module power lead. There is no danger or risk of electrical damage if the input comes off of the other transformer leg, but the input demands will not function.

Note that the dipswitch settings must be set for “Stand Alone” control. Dipswitch #9 must be “down” to enable stand alone input. Note that a change in the dipswitch position will not be seen by the control module unless the “reset” button has been pushed after the dipswitch is repositioned.

- A 24 volt signal to the demand input will turn the compressor “on”.
- A 24 volt signal to the unloader will energize the unloader (energizing the unloader reduces compressor capacity.)
- Failsafe operation is not enabled when in stand-alone mode.

Stand-alone operation may be enabled for service reasons even if a communication network is used. Communication of information is not affected by operation in the stand-alone mode. To convert back to Network mode, the reset button must be pushed for the control module to recognize the new dipswitch position.

6.0 Compressor Status Codes

The CoreSense Diagnostics control module has a LED & LCD to display the compressor status. The bicolor LED provides basic diagnostics to aid in troubleshooting of the system or compressor.

- **Steady Green:** An indication of normal operation. There are no faults or issues with the compressor.

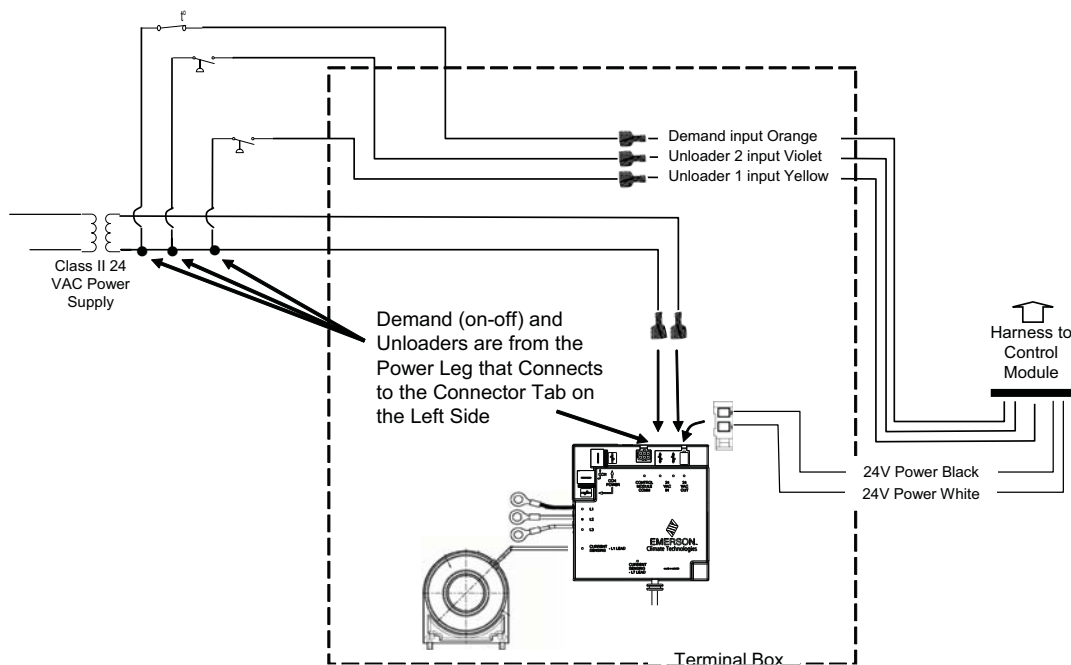

Figure 5.1
Stand-Alone Input Power Supply

- **Flashing Green:** An indication that there is a warning condition. The compressor can still be running.
- **Flashing Red:** An indication that the compressor has tripped or is in lockout state.
- **Solid Red:** An indication that the control module has failed.

6.1 Definitions

- **Trip:** The module has shut off the compressor due to a fault condition. The compressor will be available to run when the fault condition no longer exists, and the minimum off time has been satisfied.
- **Lockout:** The module has shut off the compressor due to a fault condition. The compressor will NOT be available to run when the fault condition has been cleared until the reset button is pushed or a remote reset has been activated or the module has been power cycled.

6.2 Event Priority and Troubleshooting

6.2.1 Event Priority and Anti-Short-Cycle Delay

To aid with the troubleshooting process, the event priority table is shown in section 6.3. There is a hierarchy of display, meaning that multiple events may occur at the same time and the highest priority event will be displayed on the LCD screen and on the E2 screen. This priority is in general a function of how critical the fault is. Lockouts have priority over trips, and trips have priority over warnings. The lowest priority events are those that are considered “normal” conditions.

The table includes not only the description of the event but also the display text and the corresponding LED behavior on the front of the control module. Without having to activate the LCD display (by pushing the “display” button), the LED will convey the compressor status: lockout or trip (flashing red), warning (flashing green), or normal (steady green).

After a trip occurs the compressor will run when the condition that leads to the trip is cleared. Many of the trip conditions have a minimum off-time associated with them (i.e. if the condition clears itself very quickly, the minimum off-time requirement must still be satisfied before the compressor will run). This minimum off-time is listed in the last column of the table in section 6.3.

Between normal run cycles and after trips the anti-short-cycle time delay must also be satisfied. By default this setting is 0.1 minutes (6 seconds). If the minimum anti-short-cycle delay (ASCD) controls the start of the compressor there will be an additional delay of 0.1 seconds x the node number (e.g. node #7 will have a delay of 0.7 seconds). The purpose of this feature is to prevent compressors from starting at the same time, thereby significantly reducing the electrical in-rush that the main bus will see.

6.2.2 LED Interpretation

There are two surface mount LED’s beside the RS485 communication connector on the control module. These are useful when diagnosing communication issues between the rack controller and the control module.

The left side LED is amber and indicates the receipt of a communication transmission. The right side LED is red and indicates a transmission from the control module to rack controller.

There is a bi-color LED in the sensor module that is green when power is available, and flashes red when there is an alarm condition associated with a condition that is sensed by the sensor module.

Refer to **Figure 6.1** on the following page for a description of the functionality of each module.

Module Function Architecture

Sensor Module

Advanced Motor Protection

- Locked Rotor
- Missing Phase
- Current Overload
- Voltage Imbalance
- Low Motor Voltage
- Part Winding Start Monitor
- Welded Contactor Detection

Crank Case Heater Control

Control Module

- Controller Communications
- Sensor Module Communications
- Contactor Operation
- Unloader Operation
- Motor Temperature Protection (4D/6D)
- Pressure Switch Status
- Demand Cooling Operation
- Discharge Temperature
- Oil Pressure Protection
- Supply Voltage Protection
- Configuration Settings
- Model Number
- Operating History

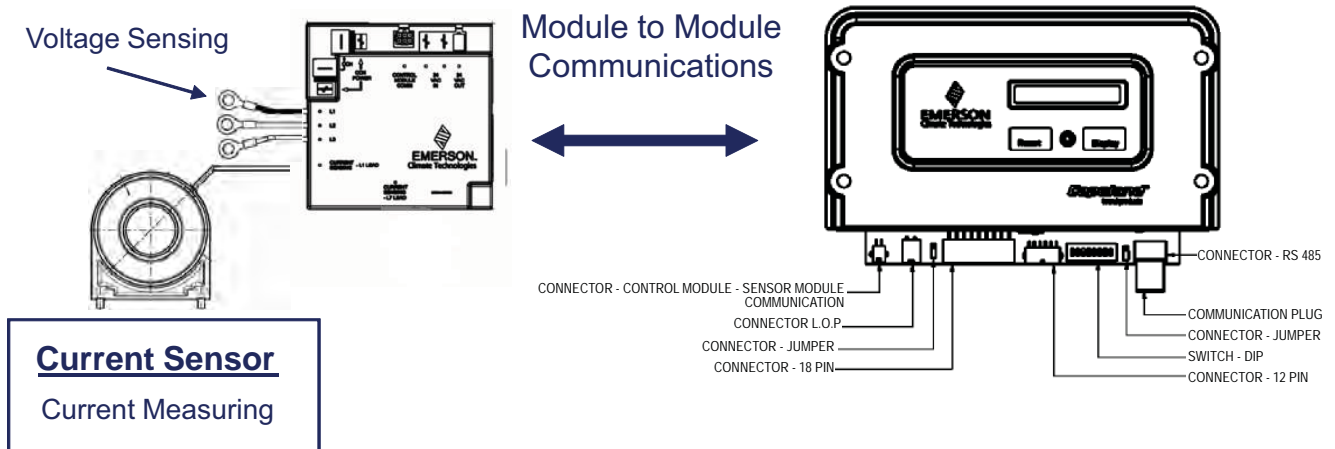

Figure 6.1

6.3 Event Priority Table

Priority	Type	Event	Control module LCD Display	Control module LED	Delay Time
1	Lockout	Repeated Phase loss for 10 times	"Phase Loss" "Lockout"	Flashing RED	NA
2	Lockout	Repeated locked rotor for 10 times	"Locked Rotor" "Lockout"	Flashing RED	NA
3	Lockout	Contactors coil over current	"Contactors Coil" "Lockout"	Flashing RED	NA
4	Lockout	Discharge temperature lockout	"Discharge Temp" "Lockout"	Flashing RED	NA
5	Lockout	Discharge pressure lockout	"High Discharge" "Pressure Lockout"	Flashing RED	NA
6	Lockout	Low Oil Pressure lockout	"Low Oil Pressure" "Lockout"	Flashing RED	NA
7	Lockout	Repeated Part Winding trip for 10 times	"Part Winding" "Lockout"	Flashing RED	NA
8	Lockout	Disabled by rack controller	"Rack Controller" "Lockout"	Flashing RED	NA
9	Trip	High discharge pressure	"High Discharge" "Pressure Trip"	Flashing RED	ASCD
10	Trip	Motor Temp Sensor Trip	"Motor Temp Trip" "Control module"	Flashing RED	Max of ASCD and 2 min
11	Trip	Phase loss trip	"Phase Loss Trip"	Flashing RED	Max of ASCD and 5 min
12	Trip	Locked Rotor Trip	"Locked Rotor" "Trip"	Flashing RED	Max of ASCD and 5 min
13	Trip	Welded Contactor Warning	"Welded Contactor" "Warning"	Flashing RED	NA
14	Warning	Low Suction Pressure	"Low Suction" "Pressure Trip"	Flashing Red	ASCD
15	Trip	Voltage Imbalance	"Voltage" "Imbalance Trip"	Flashing RED	Max of ASCD and 5 min
16	Trip	Current Over load trip	"Current Overload" "Trip"	Flashing RED	Max of ASCD and 5 min
17	Trip	No 3-phase compressor power	"No 3-Phase Power" "Trip"	Flashing RED	NA
18	Trip	Current Overload	"Current Overload" "Trip"	Flashing Red	Max of ASCD and 5 min
19	Trip	Part Winding Start Failure	"Part Winding" "Trip"	Flashing RED	Max of ASCD and 5 min
20	Trip	Module Supply voltage Trip	"Module Low" "Voltage Trip"	Flashing RED	ASCD
21	Trip	Compressor low voltage trip	"Compressor Low" "Voltage Trip"	Flashing RED	Max of ASCD and 2 min

Priority	Type	Event	Control module LCD Display	Control module LED	Delay Time
22	Trip	Discharge temperature trip	"Discharge Temp" "Trip"	Flashing RED	Max of ASCD and 2 min
23	Warning	Loss of communication between control module & E2	"No Communication" "Failsafe ON" (or OFF)	Flashing GREEN	NA
24	Warning	sensor module failure	"Sensor Module" "Failure"	Flashing GREEN	NA
25	Warning	Loss of Communication (control to sensor module)	"No Communication" "To Sensor module"	Flashing GREEN	NA
26	Warning	Low oil pressure warning	"Normal Running" "Low Oil Pressure"	Flashing GREEN	NA
27	Warning	Connection lost between CT & sensor module	"Connection Lost" "CT To Sensor"	Flashing GREEN	NA
28	Warning	Unloader1 over-current warning	"Normal Running" "Unloader1 Short"	Flashing GREEN	NA
29	Warning	Unloader2 over-current warning	"Normal Running" "Unloader2 Short"	Flashing GREEN	NA
30	Warning	Unloader1 open circuit	"Normal Running" "Unloader1 Open"	Flashing GREEN	NA
31	Warning	Unloader2 open circuit	"Normal Running" "Unloader2 Open"	Flashing GREEN	NA
32	Warning	Open Thermistor	"Normal Running" "Fault Temp Probe"	Flashing GREEN	NA
33	Warning	Unloader1 over-current warning	"Normal Off" "Unloader1 Short"	Flashing GREEN	NA
34	Warning	Unloader2 over-current warning	"Normal Off" "Unloader2 Short"	Flashing GREEN	NA
35	Warning	Unloader1 open circuit	"Normal Off" "Unloader1 Open"	Flashing GREEN	NA
36	Warning	Unloader2 open circuit	"Normal Off" "Unloader2 Open"	Flashing GREEN	NA
37	Warning	Open Thermistor	"Normal Off" "Fault Temp Probe"	Flashing GREEN	NA
38	Normal	Normal Run	"Normal Running"	Solid GREEN	NA
39	Normal	Normal Off	"Normal Off"	Solid GREEN	NA
40	Normal	Anti Short cycle timer running	"Anti short cycle" "Time XX.X m Left"	Solid GREEN	NA

6.4 Emergency Work-Around Procedures

In the event that a compressor fails to run due to an electronic module failure, the following work-around procedures are listed to assist the technician with gaining temporary control of the compressor until replacement parts may be obtained. The situations listed below will not compromise the fundamental safe operation of the compressor or agency listed motor protection features. There will be some increased risk of compressor damage associated with the loss of the module's functionality. The service technician must determine whether the risks of temporarily running the compressor in this situation are warranted.

Refer to the troubleshooting charts in the following sections before resorting to these emergency service options.

Controller fails to call the compressor “on” but network communication is active:

Unplug the RS485 connector at the control module. Set the “failsafe” dipswitch to the “run” position and then press the control module “reset” button. After 5 minutes the compressor will run in the failsafe mode. Pressure switch and motor protection features will still function.

Failed discharge temperature probe resulting in false discharge temperature trip:

Unplug the discharge temperature probe. This will generate “Fault Temperature Probe” warnings but will not prevent the compressor from running.

False motor trips or lockouts:

Faults that are associated with the sensor module or current sensor (see **Figure 6.1** above) are advanced protection features beyond the basic motor temperature or current limiting protection available on all discus compressors. If troubleshooting leads to the conclusion that the trips or lockouts are false, the sensor module communication harness may be unplugged from the control module. This will generate a “no communication to sensor module” warning but will allow the compressor to run. If the sensor module communication is unplugged - all of the advanced motor protection features will be bypassed. If the problem is associated with the current sensor itself, this may be unplugged from the sensor module leaving fundamental communication between the sensor and control module intact.

Emergency By-Pass Procedure:

Refer to **Section 6.13: Fail-Safe Inoperable**.

6.5

Normal Running

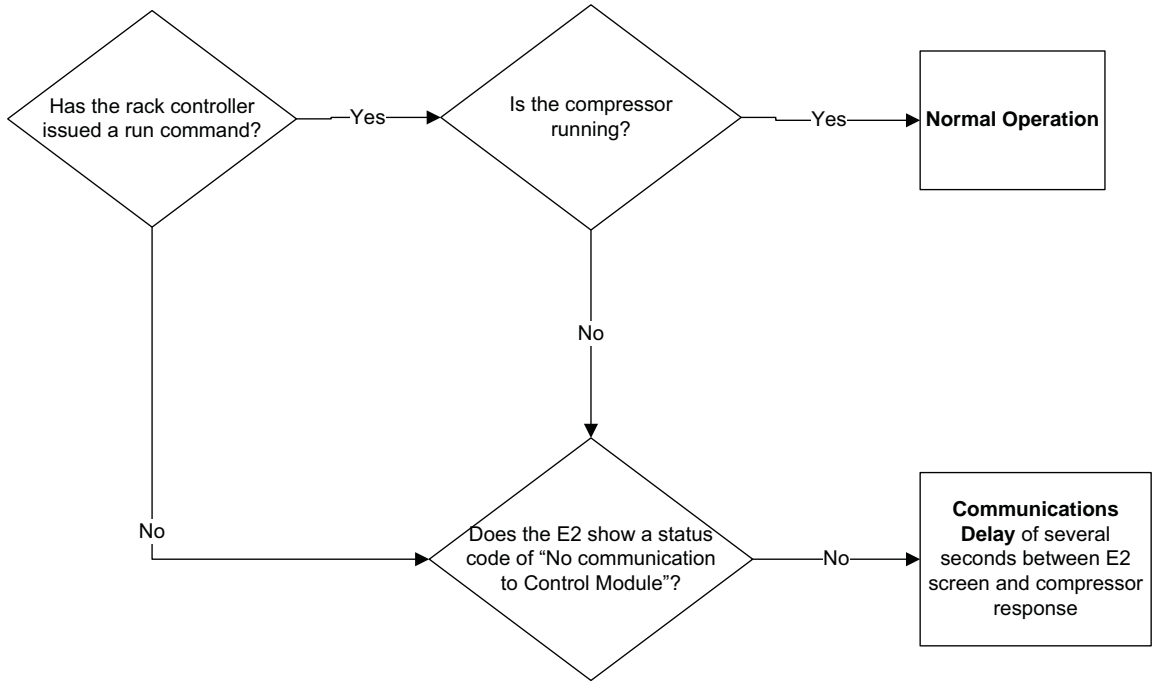

Normal Running:

- Demand is present
- Current > 5 amps
- Motor voltage is present
- No faults

The control module will display amperage and discharge temperature

Normal Operation. The module has gone into "loss of communications" mode and the failsafe is set to ON. Refer to section 6.14 for the communications troubleshooting procedure.

6.6

**Normal – OFF
Fail Safe - OFF**

- No Demand
- Motor Current < 5 amps
- No Voltage
- No Communication; Fail Safe Set For "Off"

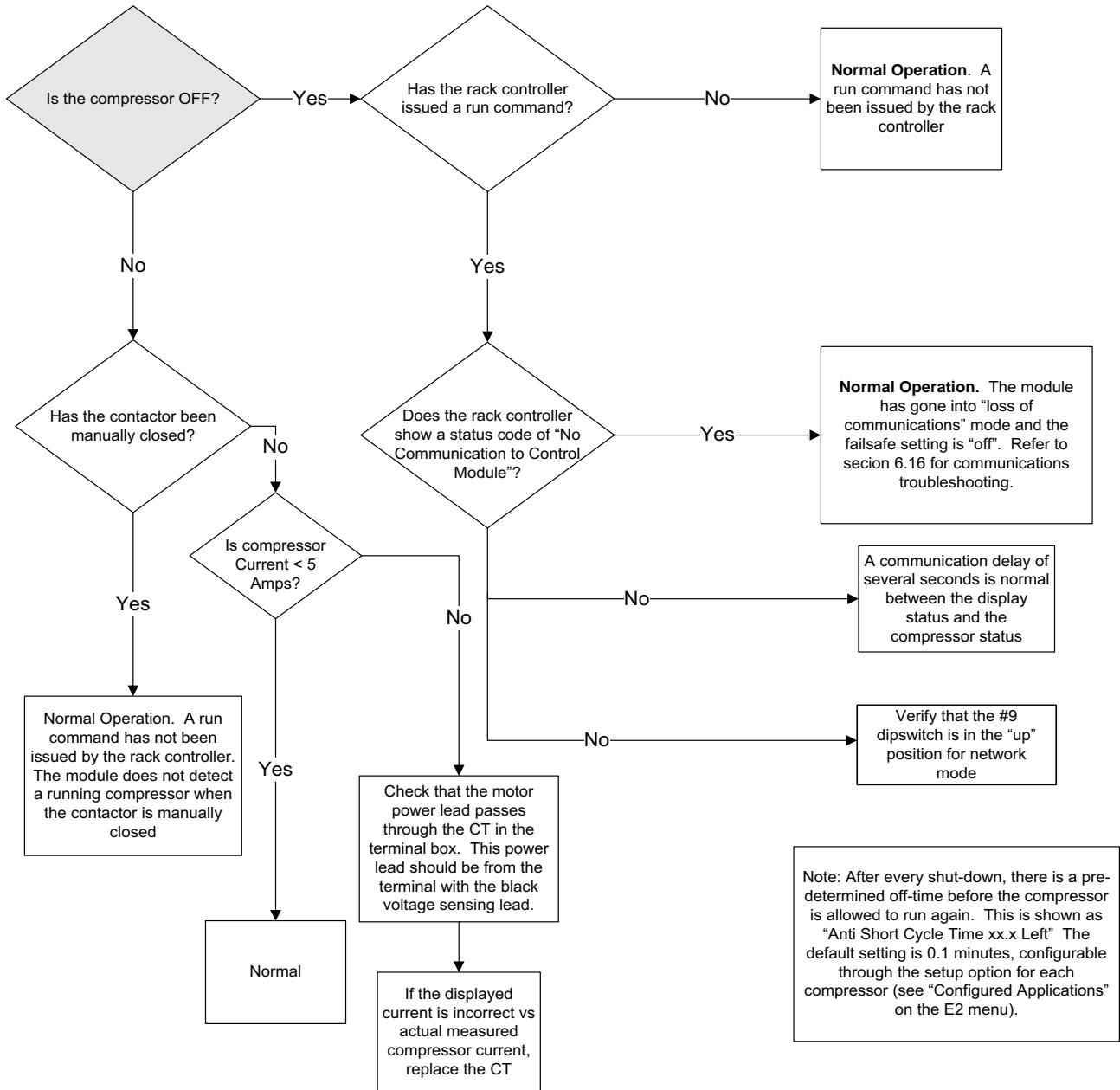

6.7

**Forced Run
Welded Contactor Warning**



Warning: The motor power connections are high voltage. Disconnect power to the compressor before accessing connections in the terminal box

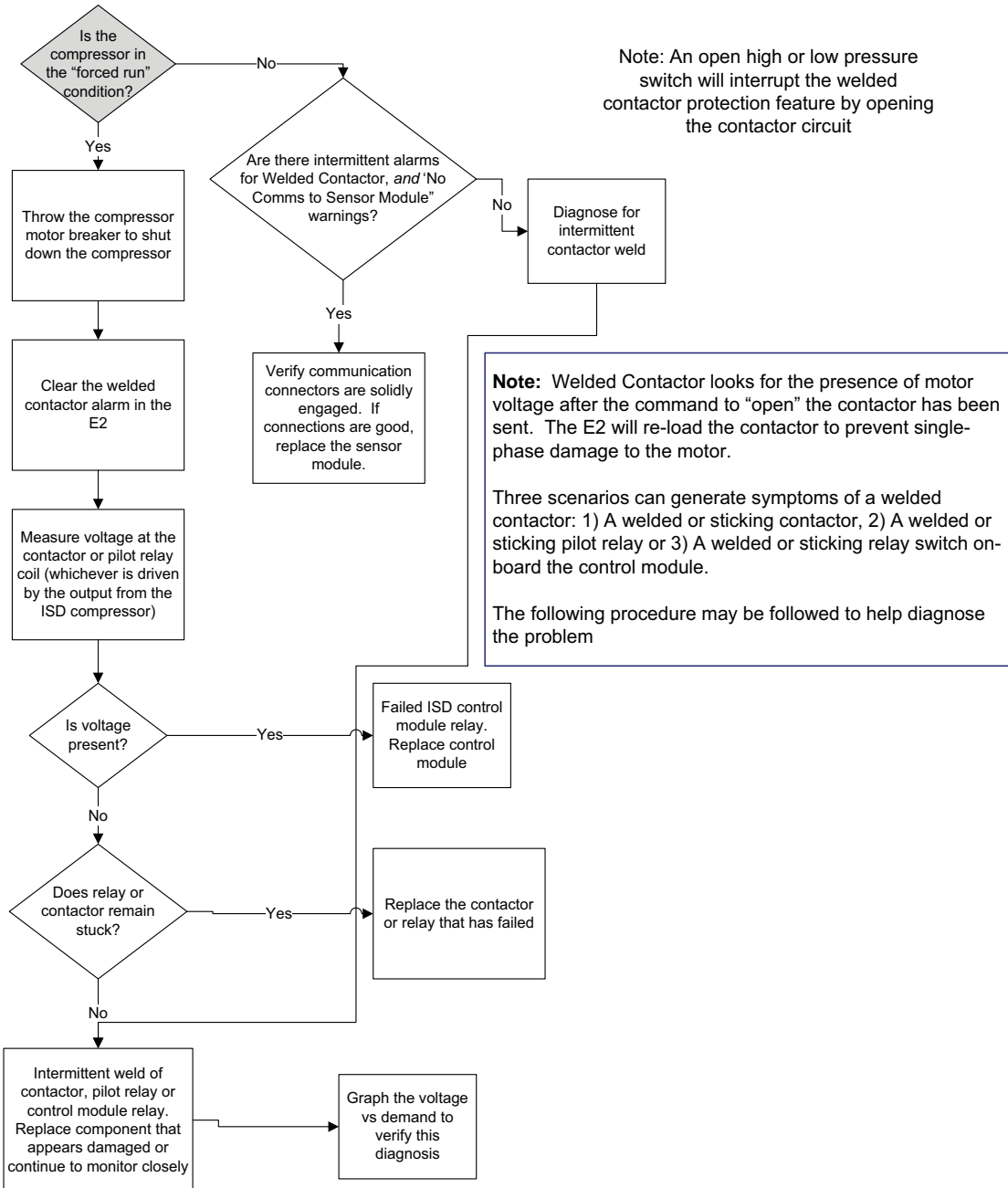

Note: An open high or low pressure switch will interrupt the welded contactor protection feature by opening the contactor circuit

Note: Welded Contactor looks for the presence of motor voltage after the command to "open" the contactor has been sent. The E2 will re-load the contactor to prevent single-phase damage to the motor.

Three scenarios can generate symptoms of a welded contactor: 1) A welded or sticking contactor, 2) A welded or sticking pilot relay or 3) A welded or sticking relay switch on-board the control module.

The following procedure may be followed to help diagnose the problem

6.8

Module Low Voltage Trip

Sensor Module input voltage must be greater than 16.5 volts



Warning: The motor power connections are high voltage. Disconnect power to the compressor before accessing connections in the terminal box

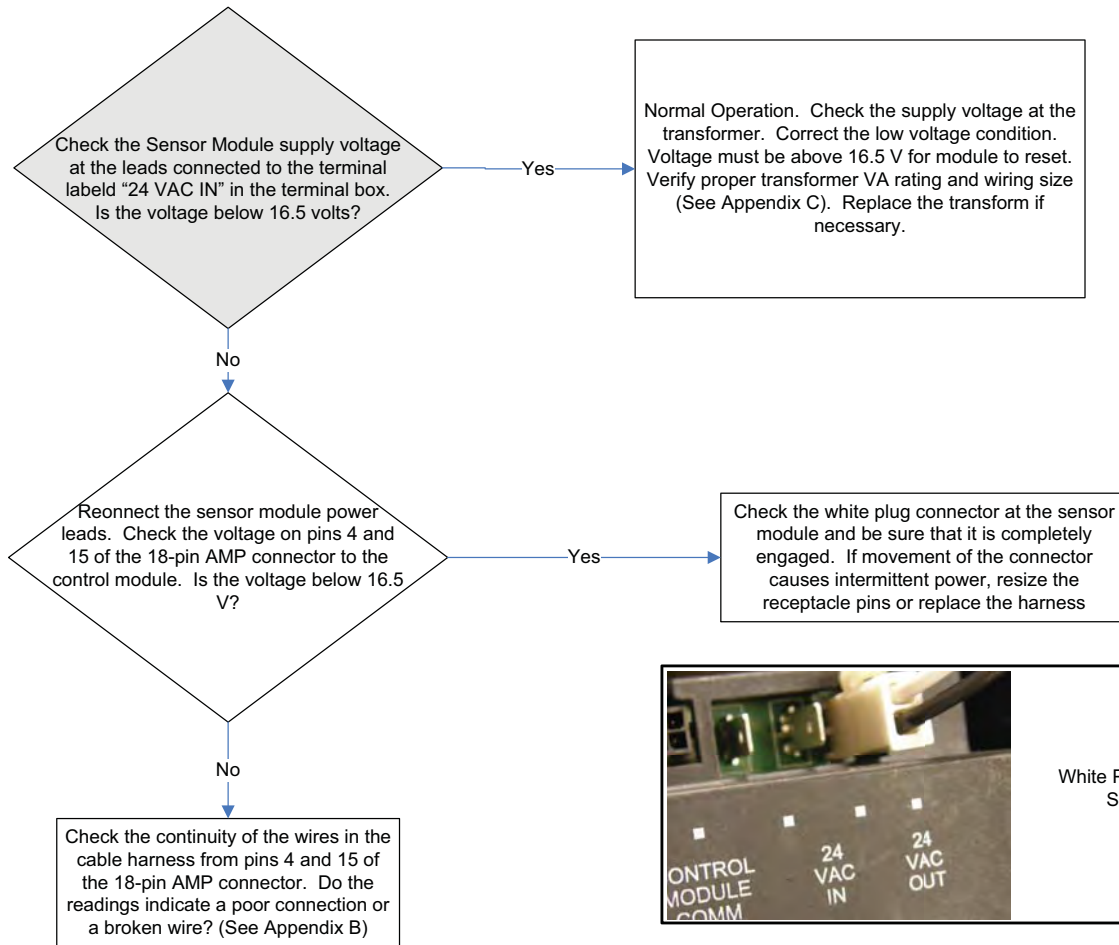

Note: The 24VAC supply voltage to the control module is also used to provide power to the unloader coil(s) if present. In the event of intermittent low voltage trips it may be helpful to check the transformer output voltage while overriding the unloader coil ON with the rack controller. This can be done by forcing the unloader stage "OFF".

If powering the unloader coil(s) causes the supply power to the module to drop below 16.5 v, check to be certain that the transformer meets the proper VA requirements. Refer to Appendix C of this manual for information concerning proper transformer selection.

6.9

Connection Lost CT to sensor

CT is the Current Sensing Transducer, located in the terminal box. It is the round "toroid" that one of the motor power leads passes through. This code is generated when it is unplugged from the Sensor Module, or the motor power lead isn't passing through the CT.



Warning: The motor power connections are high voltage. Disconnect power to the compressor before accessing connections in the terminal box

Resistance across these pins is less than 1 ohm

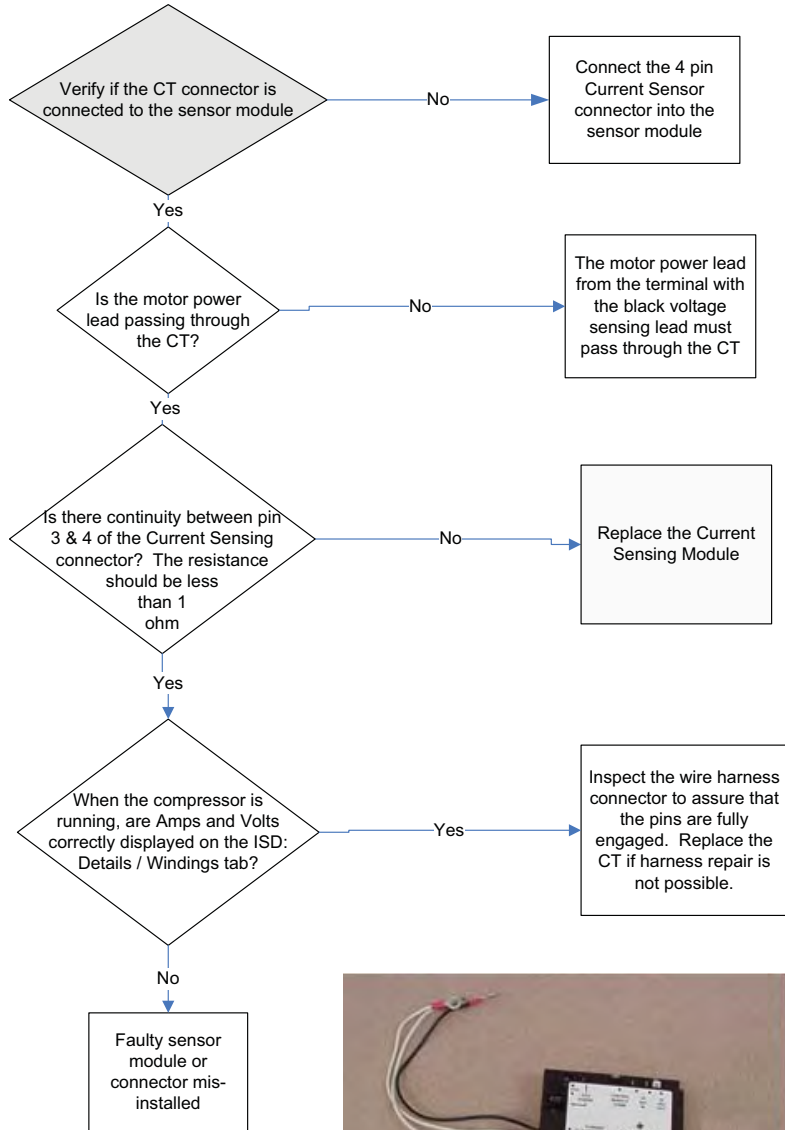
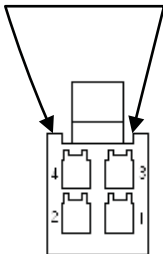

Current Sensing Module connection to Sensor Module

Current Sensing Module

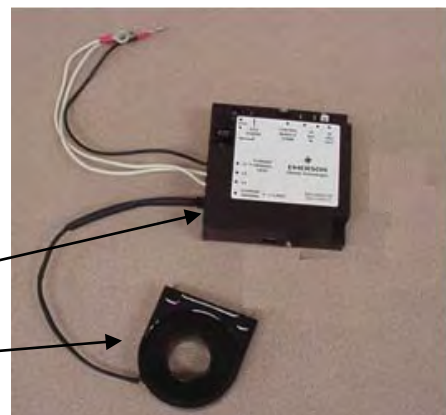

6.10

Rack Controller Lockout

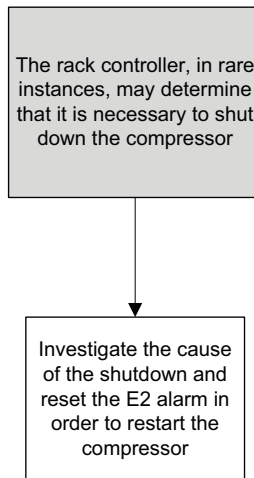

6.11

Fault Temperature Probe

The temperature probe is an "NTC" device. Its resistance increases with decreasing temperature. This fault is generated by an "open" thermistor circuit, and as such will generate a reading of a low temperature (-40F or +327F with some versions of control module). This assessment is only made if the control module temperature is greater than -30F.

Temperature probe connections should be coated with NyoGel 760G lubricant. Kit # 9170001-00

Normal Operation
Connect the harness to the temperature probe

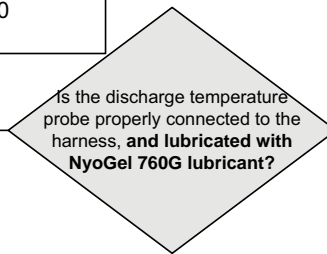

Unplug the temperature probe and check the resistance of the probe vs the attached table

Replace temperature probe

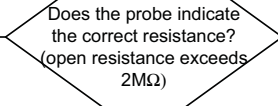

Temperature Resistance	
60F	141K ohms
70F	107K ohms
80F	82K ohms
90F	66K ohms

Opened harness circuit. Verify that the harness is fully engaged to the low voltage connector at the control module. Perform continuity check of harness to isolate fault. Refer to the wiring diagram in the appendix.

Temporarily "short" across the sensor connectors on the harness. **Do not distort the connectors when doing this.**

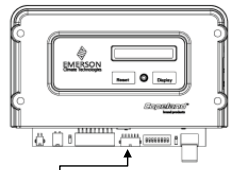

Low Voltage Connector

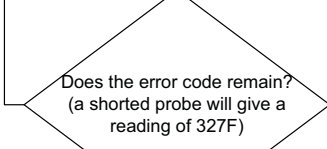

Intermittent probe failure, loose connector pins or intermittent harness failure

6.12

Fail-Safe Inoperable

The fail-safe feature exists for conditions involving the loss of communication to the controller (wire failure, controller failure, etc.). In the event of an electronics failure of the control module, the use of an emergency jumper may be used to force the compressor "on" while still utilizing the high and low pressure switches on the compressor.

When using this jumper, note that the following protection features are bypassed at your own risk:

- 4D / 6D motor protection is disabled
- Oil pressure protection
- Discharge temperature protection
- All protection features provided by the sensor module
- Unloader operation

2D and 3D line-break protection is still operable with this by-pass arrangement

Connect the jumper between the contactor connection that goes to the black contactor output wire

Connect the other end of the jumper to one of the low pressure switch tabs. If the compressor fails to run, reconnect the low pressure switch wire and then connect the jumper to the *other* tab

Emergency By-Pass Jumper

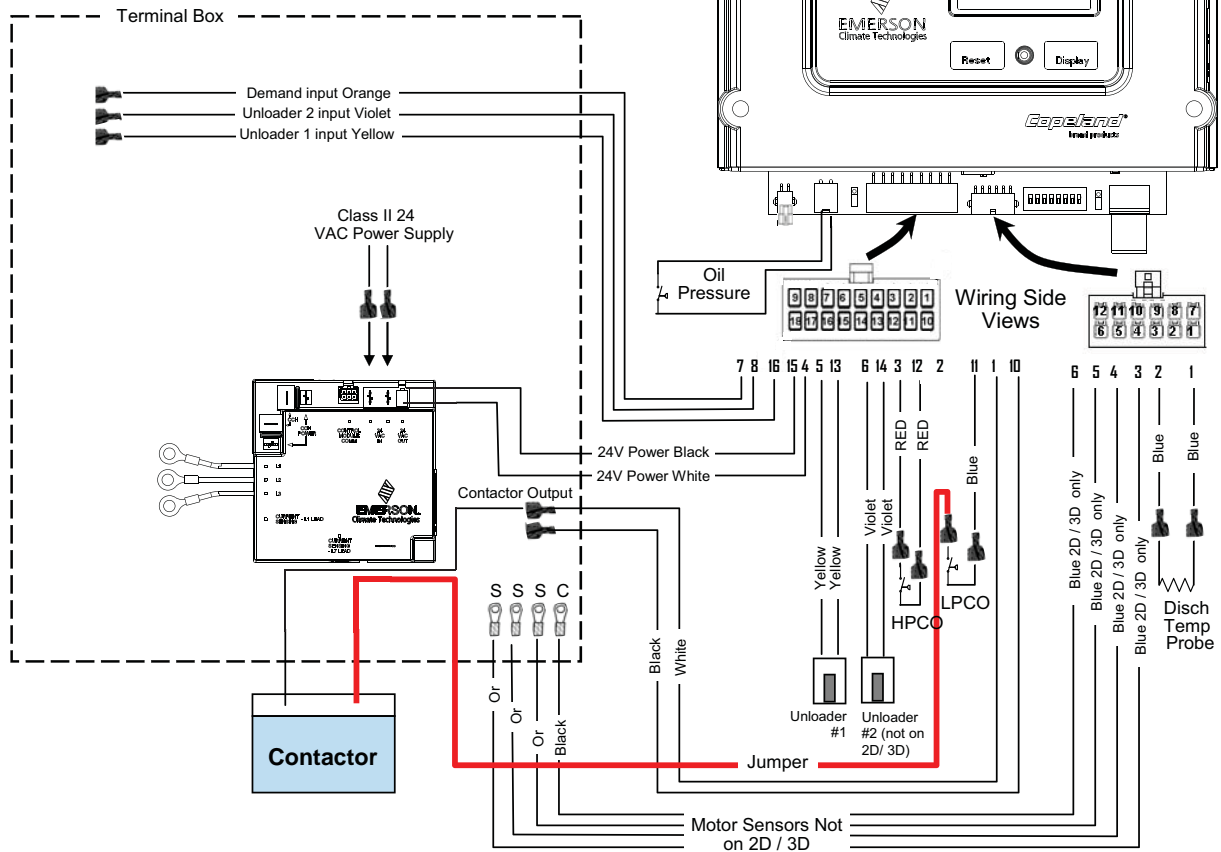

6.13

Locked Rotor Trip / Lockout

A detected locked rotor condition (at start-up or while running) will shut the compressor off for 5 minutes. After 5 minutes, an attempt will be made to run again if demand is still present. After 10 consecutive locked rotor trips, the control module will transition to a LOCKOUT condition. A reset is necessary in order for the module to run again.

If the compressor is locked out, RESET the module to enable it to run again.

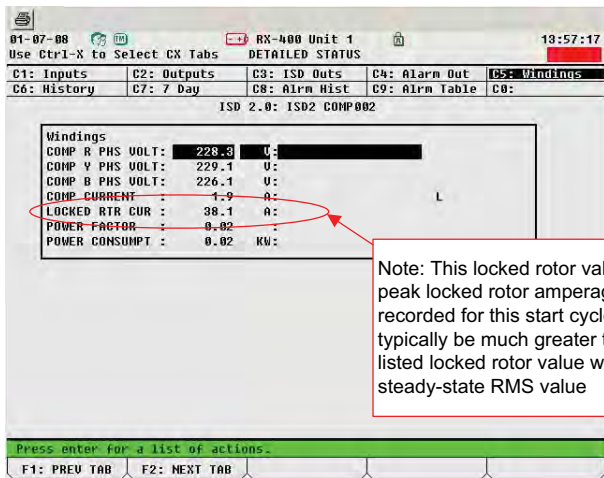
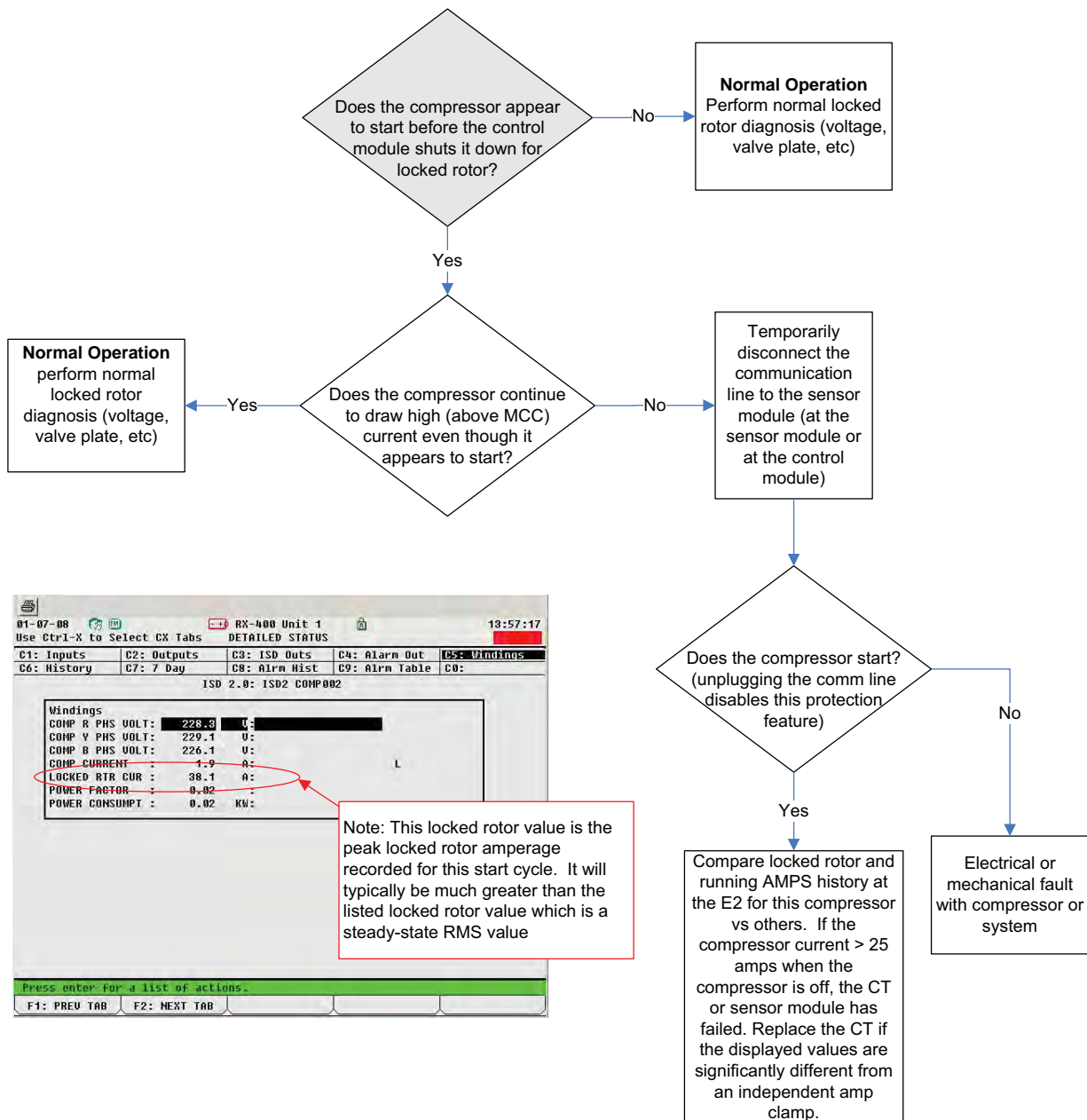

Note: This locked rotor value is the peak locked rotor amperage recorded for this start cycle. It will typically be much greater than the listed locked rotor value which is a steady-state RMS value

6.14 a

No Communication

"No Communication" will be shown on the ISD display. It will be seen in the E2 detail status screen as the ISD Display Code, and the Network Status will be "Offline".

After 5 minutes of no communication, the control module of the compressor will revert to the Failsafe run state.

This flow chart assumes that the initial commissioning process has been completed to establish the node on the network.

The control module must be "on" and the RS485 connector must be plugged in to the control module and to the E2 controller (see E2 connection in photo on the right)

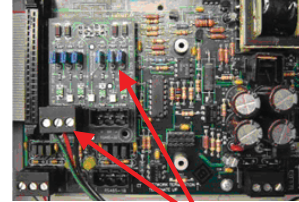

Communication Card and Connector

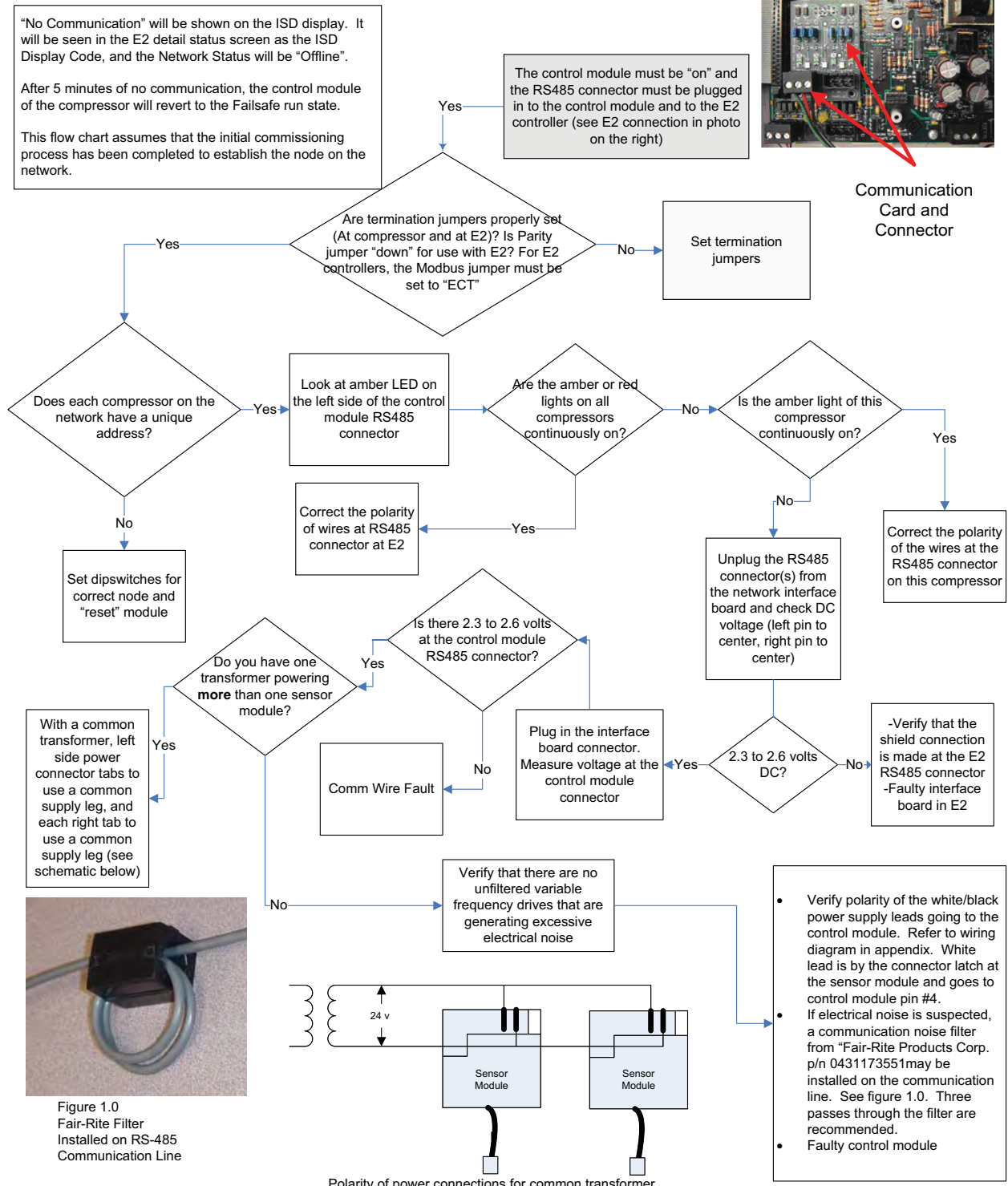
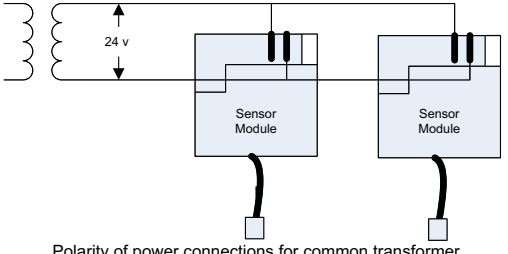

Figure 1.0
Fair-Rite Filter
Installed on RS-485
Communication Line



Polarity of power connections for common transformer

6.14b

No Communication to Rack Controller (Continued)

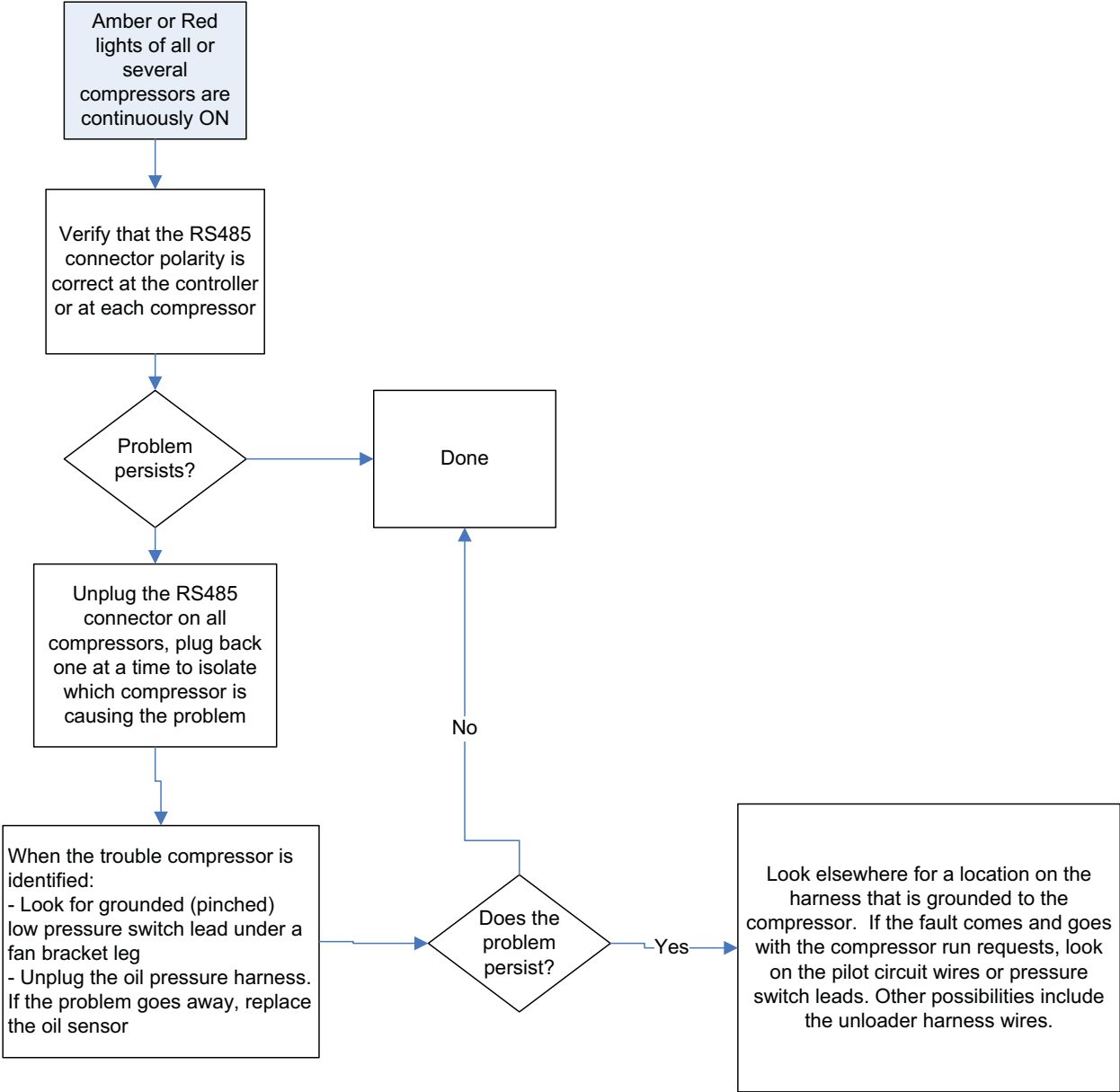

6.15

Motor Temperature Trip

Motor temperature protection for 4D and 6D compressors utilizes 3 temperature sensors in the motor. The temperature sensor resistance is measured by the control module to determine whether or not to shut down the motor. The motor temperature set point is not configurable (it is a fixed value).

Normal reset requires that the compressor be off for 2 minutes and the sensor temperatures be below a reset resistance (see below)

Warning: The motor power connections are high voltage. Disconnect power to the compressor before accessing connections in the terminal box

Verify that the low voltage connector is plugged into the control module

Emergency Sensor Bypass Instructions:

In the unlikely event that ONE sensor may be damaged and have an open circuit, the control module will prevent compressor operation even though the motor may be in otherwise perfect condition. If such a situation should be encountered in the field, an emergency means of operating the compressor can be used until such time as a replacement can be made. Disconnect the orange lead that is connected to the faulty sensor, and move it to the common (black wire) post. Stack the two ring terminals (one black and one orange) together on the common post.

Caution: High Voltage Inside Terminal Box
Check the motor sensor resistance (this may be checked at the control module by unplugging the low voltage harness

Allow the compressor to cool for one hour. Verify proper nut torque (20 in-lb) of motor temperature terminal strip nuts in the terminal box. The sensor to common resistance on a cold motor should be between 20 and 250 ohms. Reset values for a hot motor are 2700 – 4500 ohms.

See emergency bypass instructions above

Are the sensors within spec?

Does the fault remain?

Possible Causes:
1.) Open circuit in harness
2.) Connector pin not engaging at connector on control module
3.) Faulty control module

Resolve source of high motor temperature

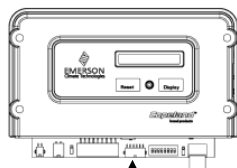

Low Voltage Connector

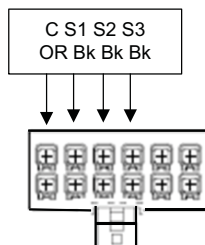

Open end view of low voltage harness, unplugged from the control module

Motor Sensor Resistance Values:

Cold: 20 – 100 ohms
Reset after trip: 2750 ohms

6.16

No Communication to Sensor Module

This code results when the sensor module communication harness is unplugged for 1 minute, or the control module fails to communicate with the sensor module for 1 minute

Remove the Bottom cover of the control module

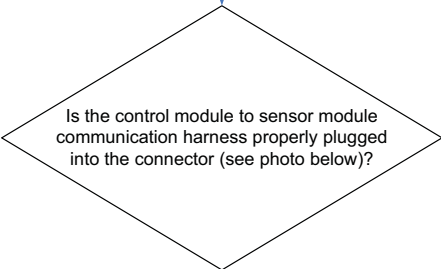

No
Properly plug the harness into the connector

Yes
Open the terminal box
(Caution: High Voltage on Terminal Posts).

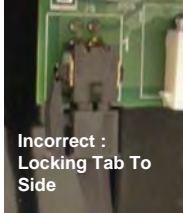

Orientation of communication harness connector

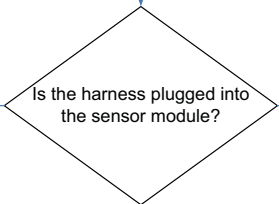

Yes
Replace the sensor module

No
Plug the harness into the sensor module

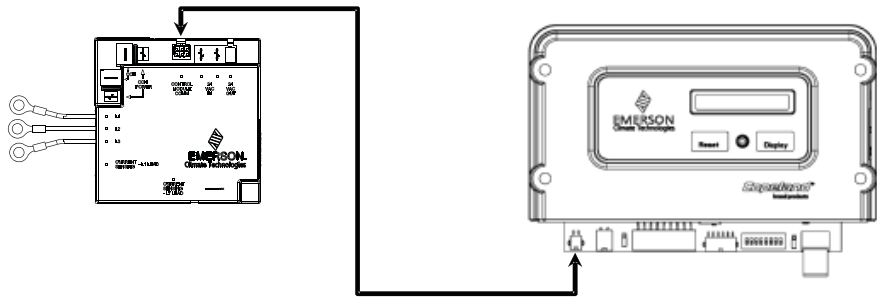

Communication Harness Connector Locations on Control and Sensor Module

6.17

Unloader Short

The unloader short protects the harness and electronics from high current (2 ± 0.5 Amps) associated with a shorted coil or harness. The control module must be reset to allow the unloader to be operated again.

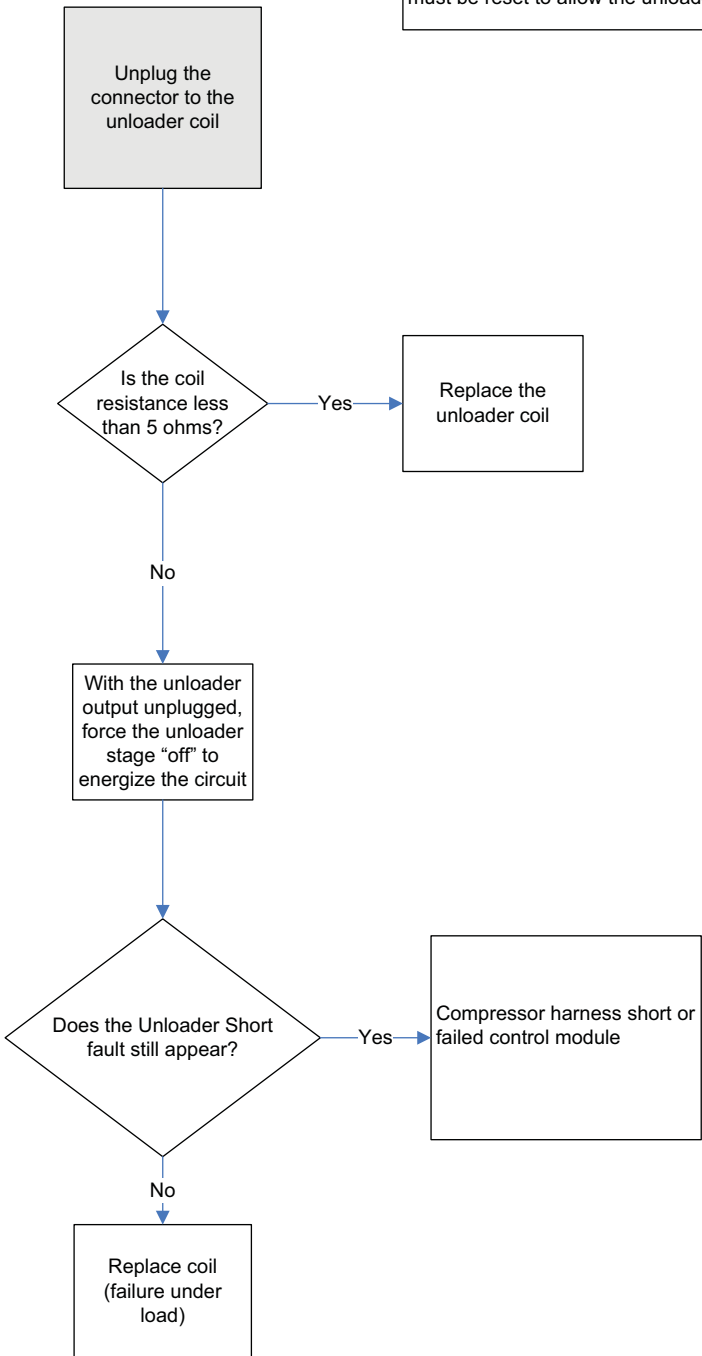

6.18

Unloader Open

The "open" unloader coil detection is based on a low current flow (<200 mA) through the unloader coil. This feature is disabled for the Demand Cooling solenoid coil

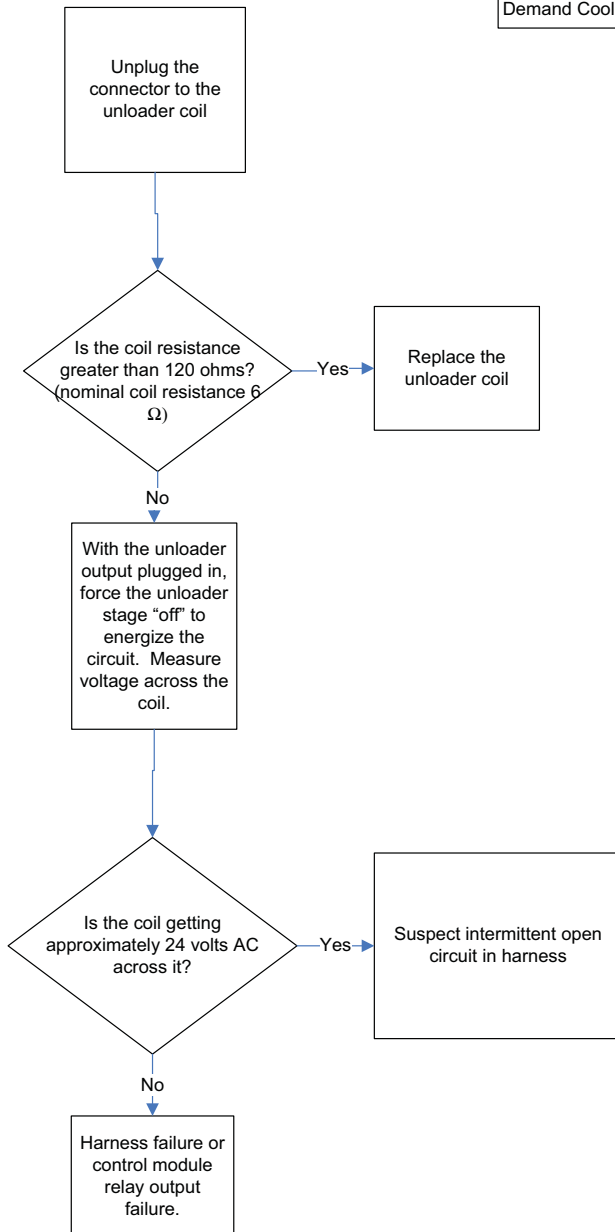

6.19

Contactor Coil Lockout

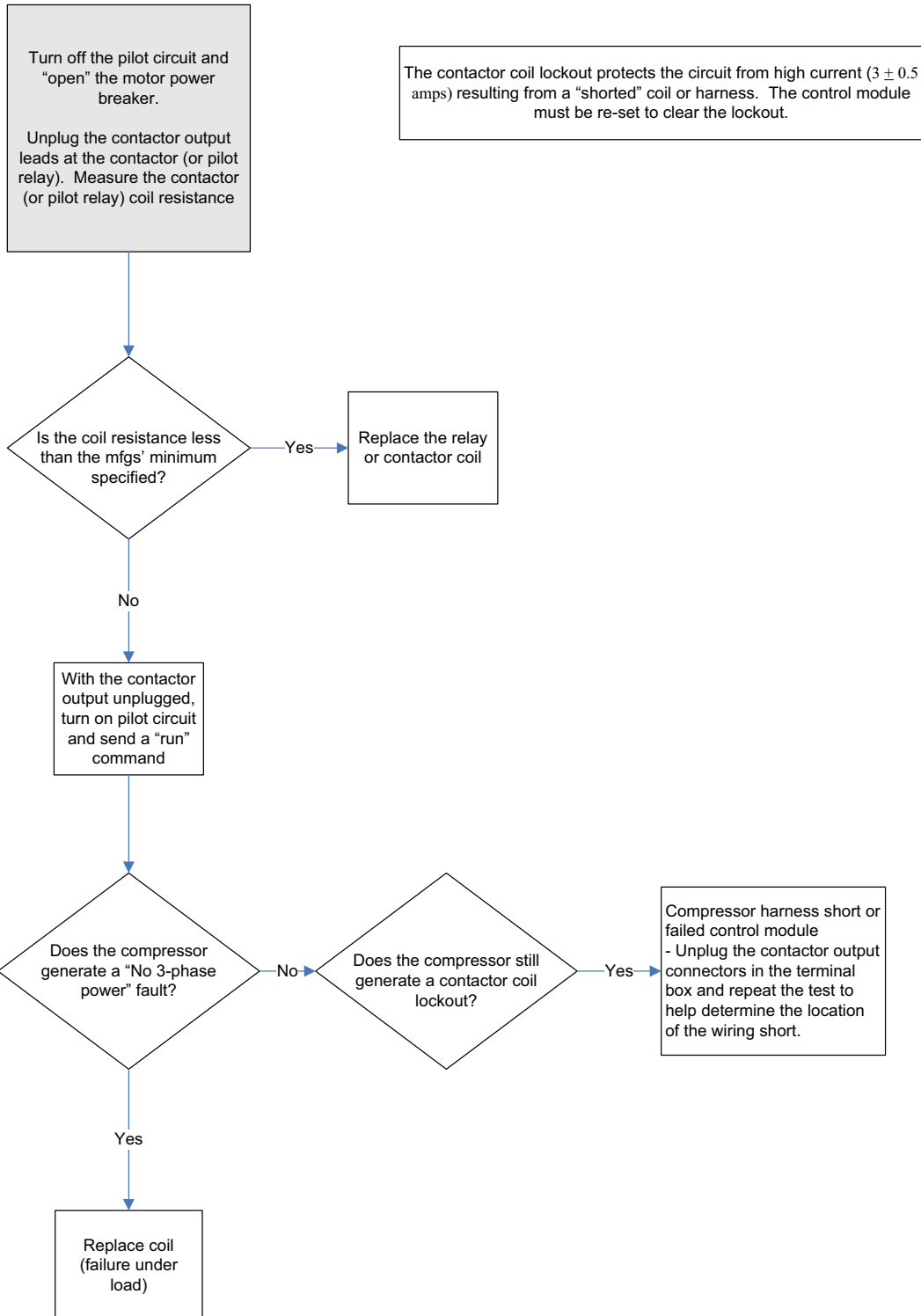

6.20

Protector Trip

This fault pertains to 2D and 3D compressors with internal line break protectors. The presence of motor voltage without current flow is the symptom used to detect a protector trip. Current flow is measured by the Current Sensing Module ("CT", for Current Transducer)

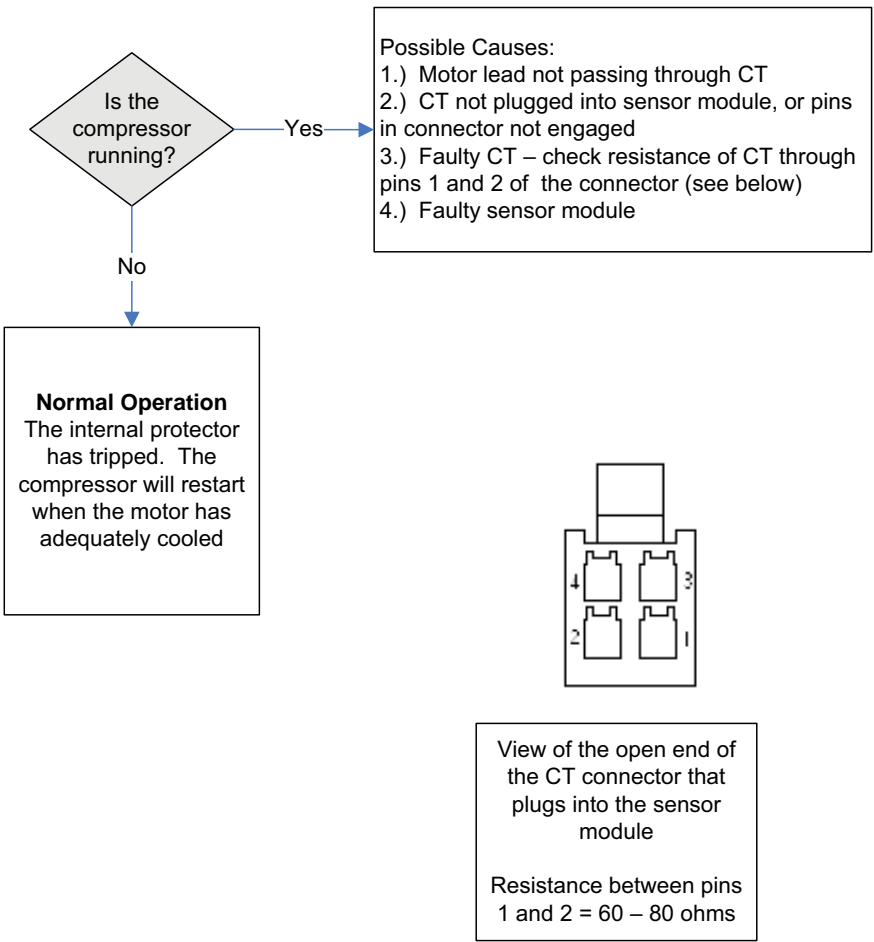

6.21

Voltage Imbalance Trip

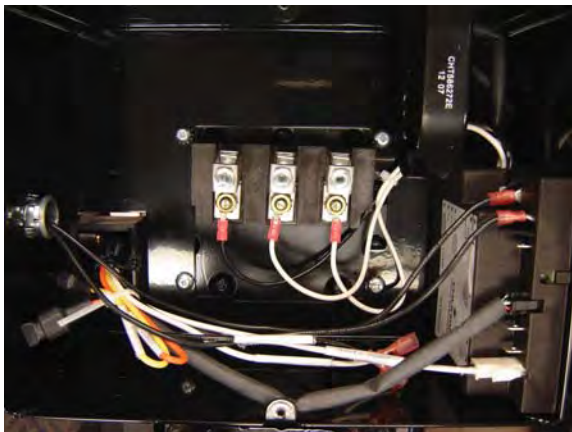
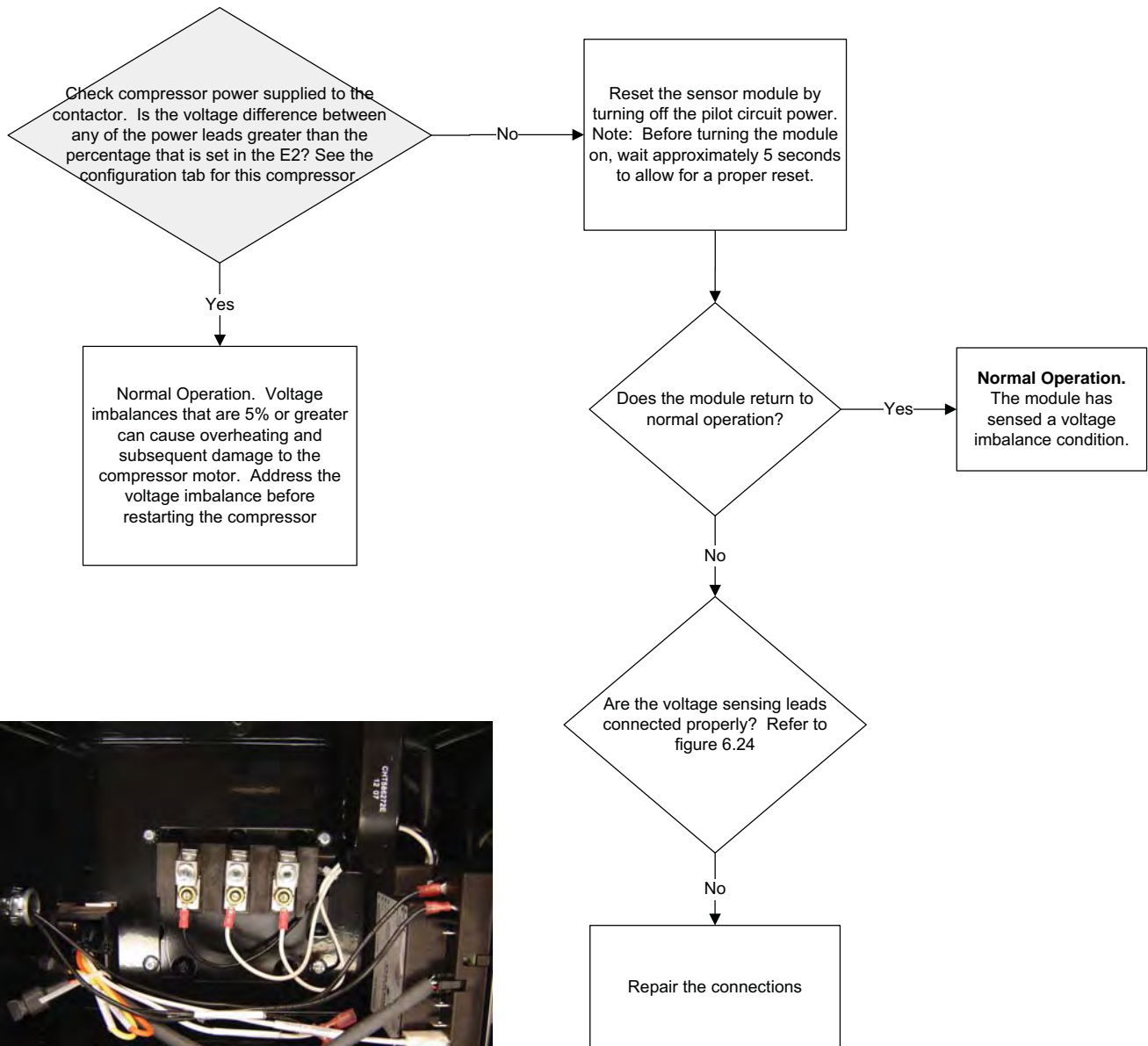
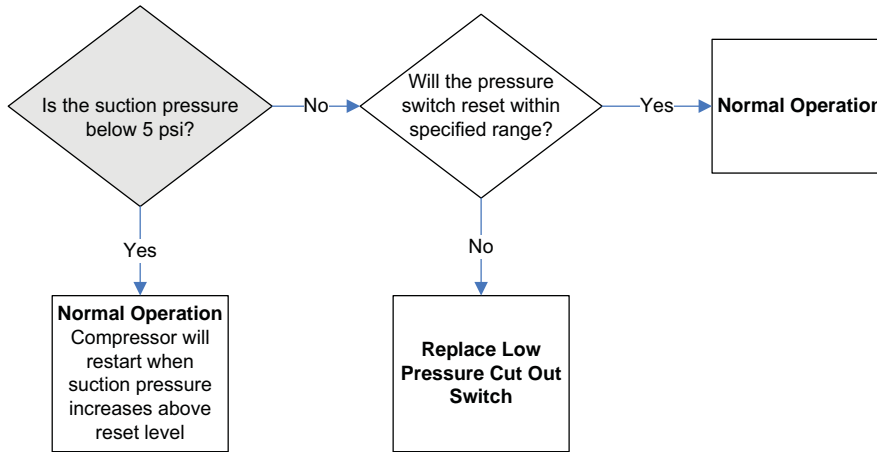

Figure 6.24 Voltage Lead Connections

6.22

Low Suction Pressure Trip



2D / 3D

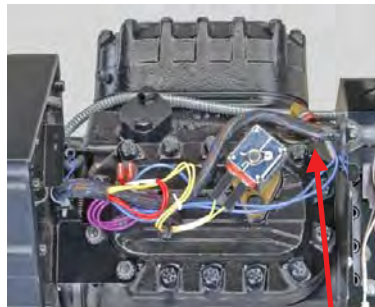

4D

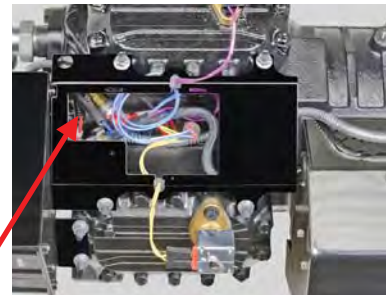

6D

Low Pressure Cut Out Switch Locations

Non-Demand Cooling Low Pressure Switch Settings:

Opens 1 to 5 psi
Closes 8 to 12 psi



Demand Cooling Low Pressure Switch Settings:

Opens -5 to +1 psi
Closes 5 to 11 psi



6.23

Phase Loss Trip / Lockout



Warning: The motor power connections are high voltage. Disconnect power to the compressor before accessing connections in the terminal box

A phase loss trip occurs if one or two phases of the motor are not receiving voltage. The compressor will shut off and remain off for 5 minutes before trying again. If the phase loss occurs for 10 consecutive attempts, a lockout will occur. A lockout requires that the module be reset to allow the compressor to run. Every successful re-start will decrement the lockout counter by one.

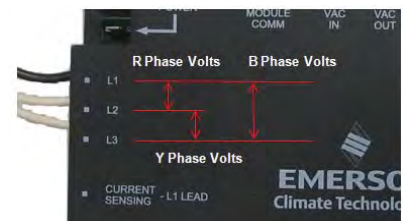

Normal Operation
Determine cause of missing phase or voltage imbalance

Is full voltage present at each terminal when the contactor is loaded?

Voltage sensing leads not connected to motor terminals.
Note that during a light-load running condition, the missing-phase voltage imbalance may not be very large

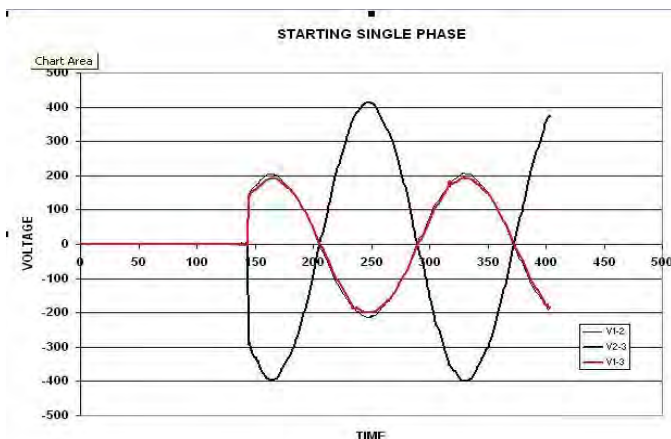

Missing Phase Voltage Imbalance During Start-up

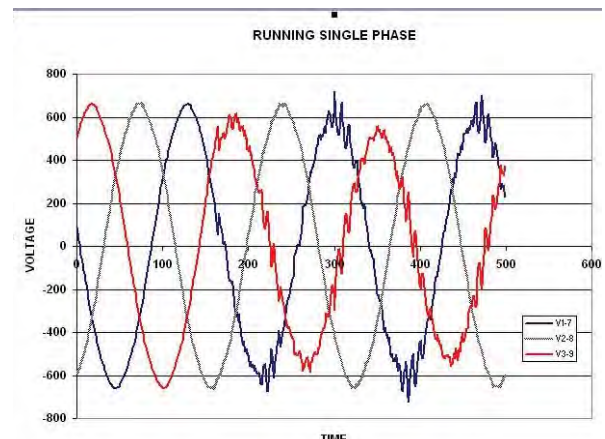

Missing Phase Voltage Imbalance While Running

6.24

No 3-Phase Power



Warning: The motor power connections are high voltage. Disconnect power to the compressor before accessing connections in the terminal box

No 3-phase power fault occurs if a run command has been sent from the control module to the contactor (or pilot relay) and voltage isn't present at the motor terminals. This will not result in a lockout condition; If demand remains, the compressor will continue to attempt to run until voltage at the motor is present. This fault will typically occur during start-up.

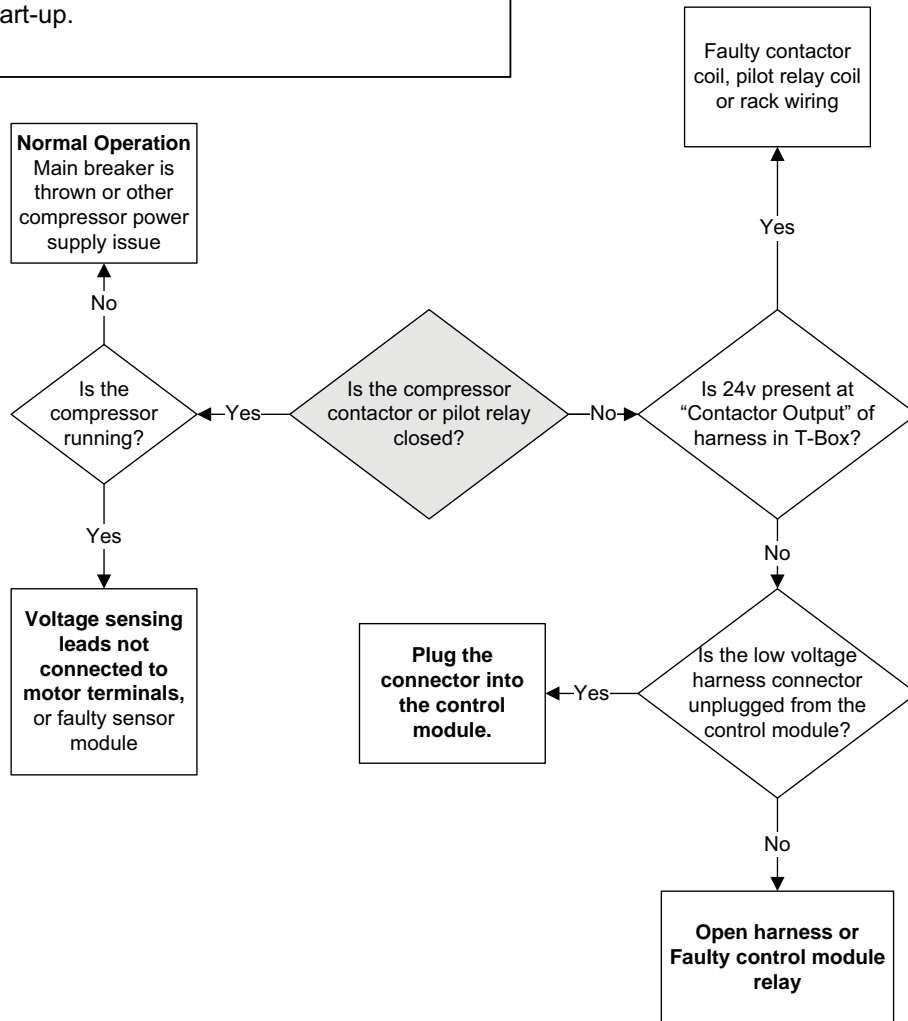

6.25

**Normal Running Low Oil Pressure
Followed By
Low Oil Pressure Lockout**

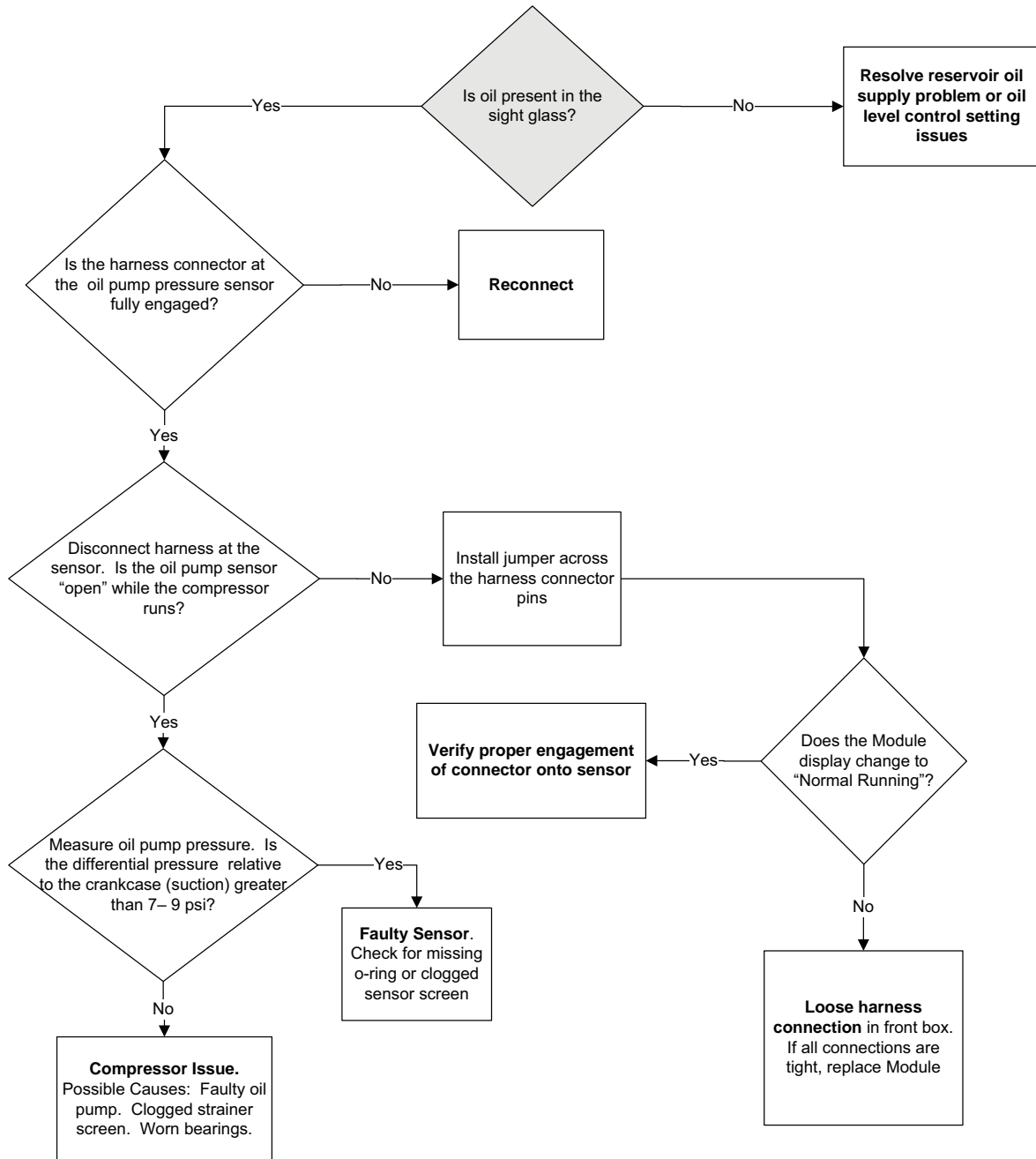

6.26

Control Module Failure Lockout

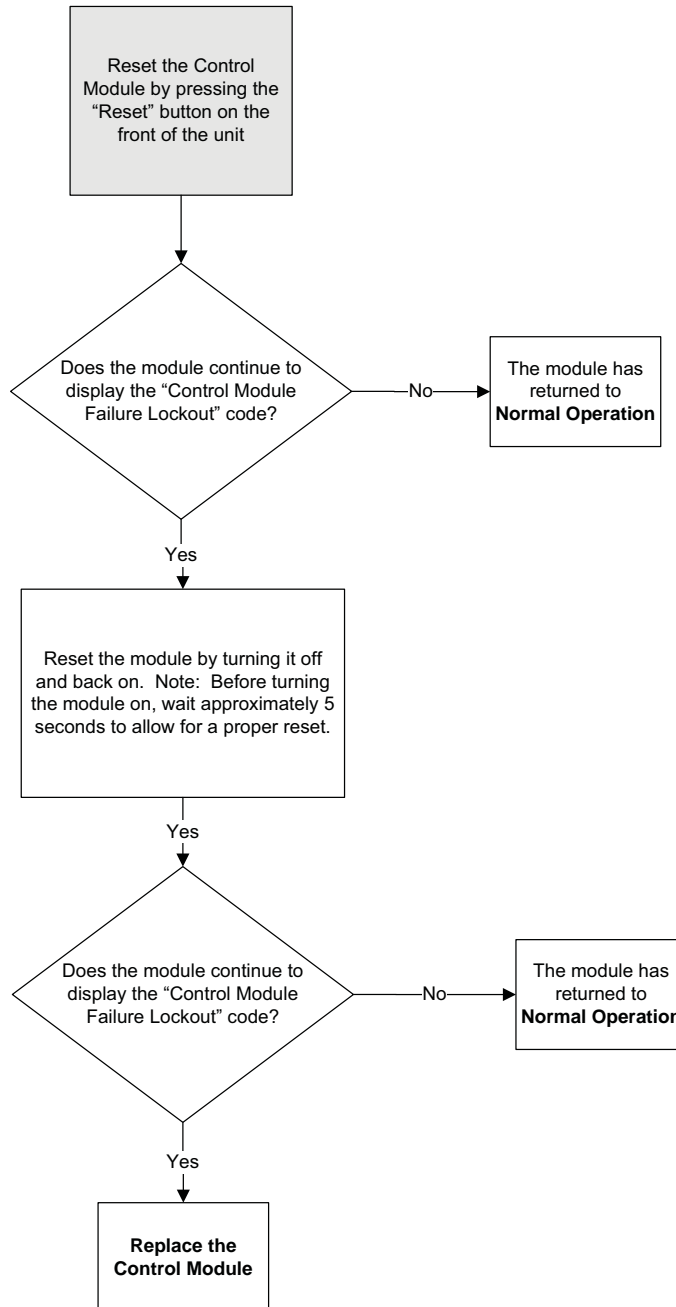

The Control Module Failure Lockout code results when the module fails an internal diagnostic test.

6.27

Sensor Module Failure

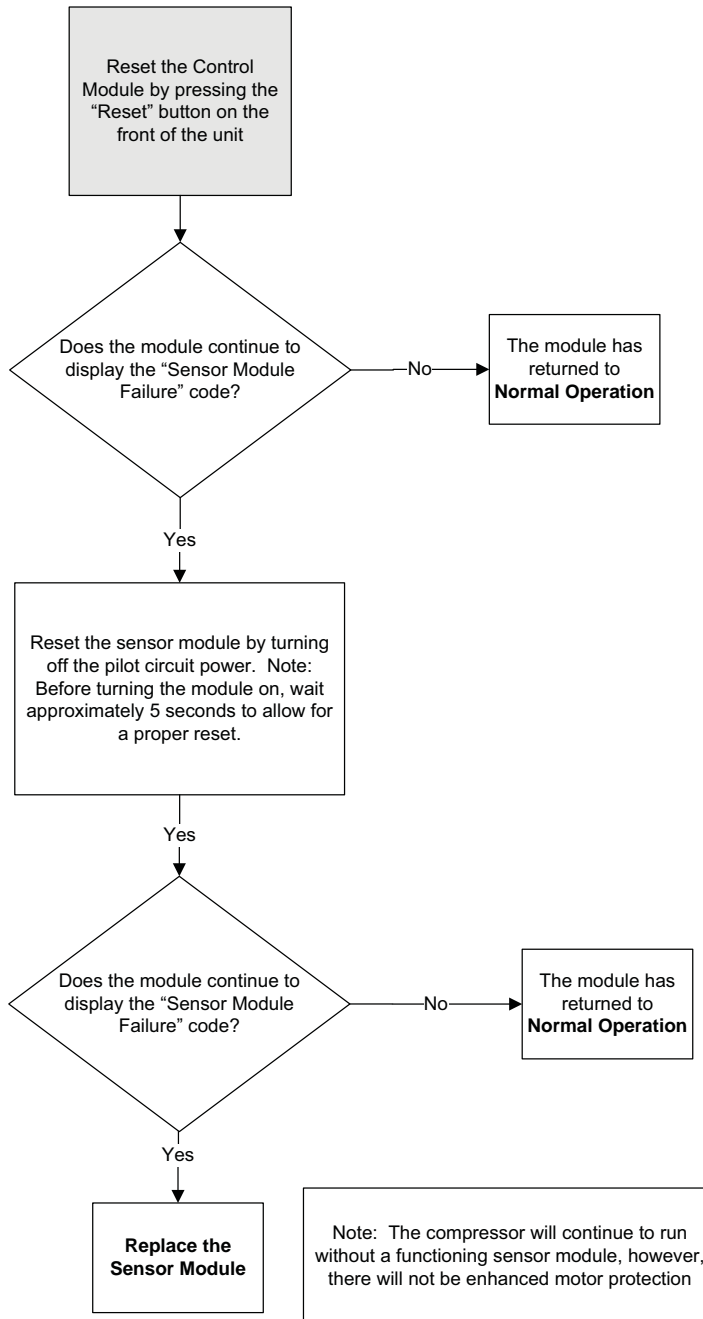

The Sensor Module Failure code results when the module fails an internal diagnostic test.

6.28

High Discharge Pressure Trip

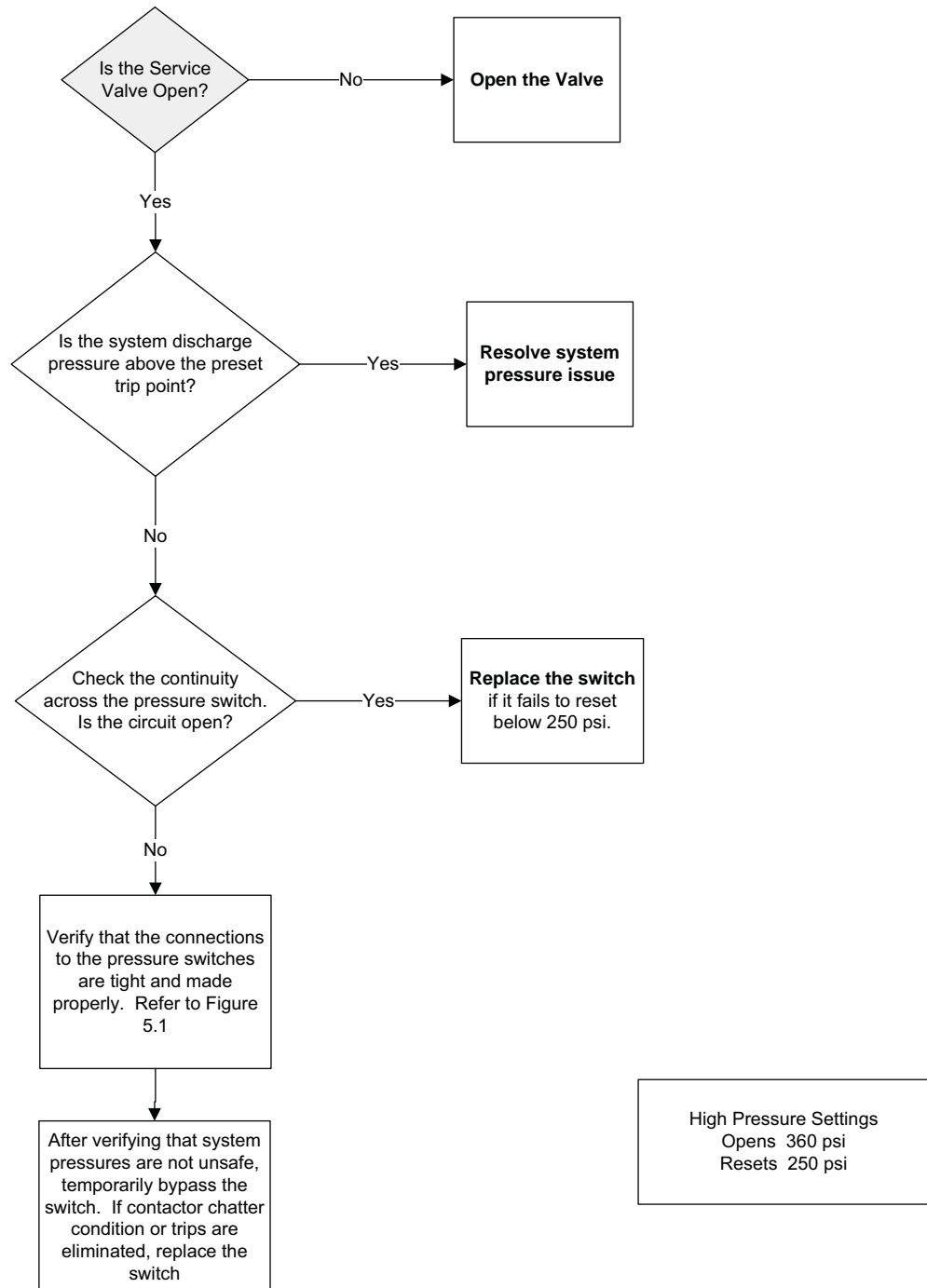

6.29

Discharge Temperature Trip / Lockout

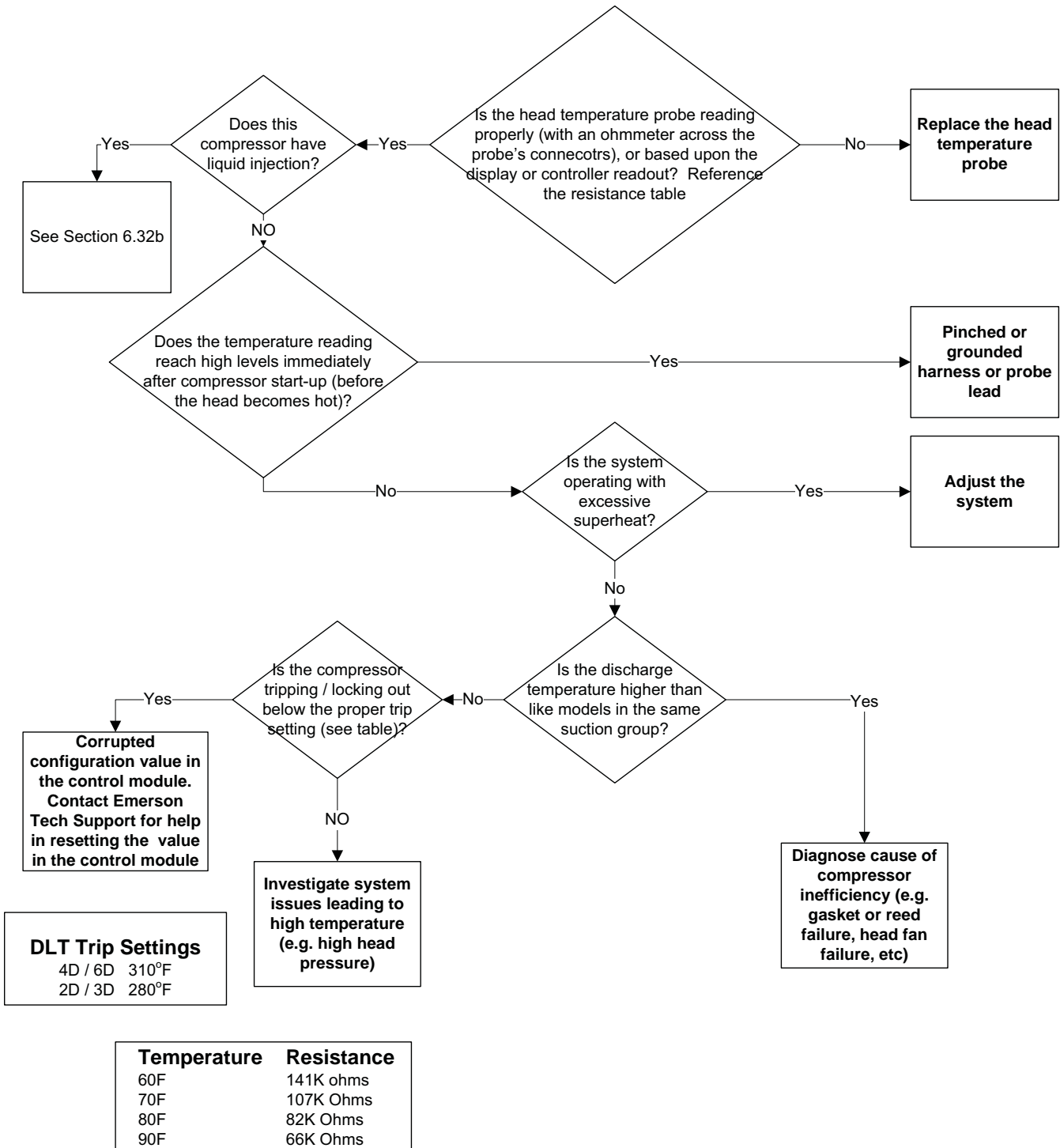

6.29 b

**Discharge Temperature Trip / Lockout
With Demand Cooling**

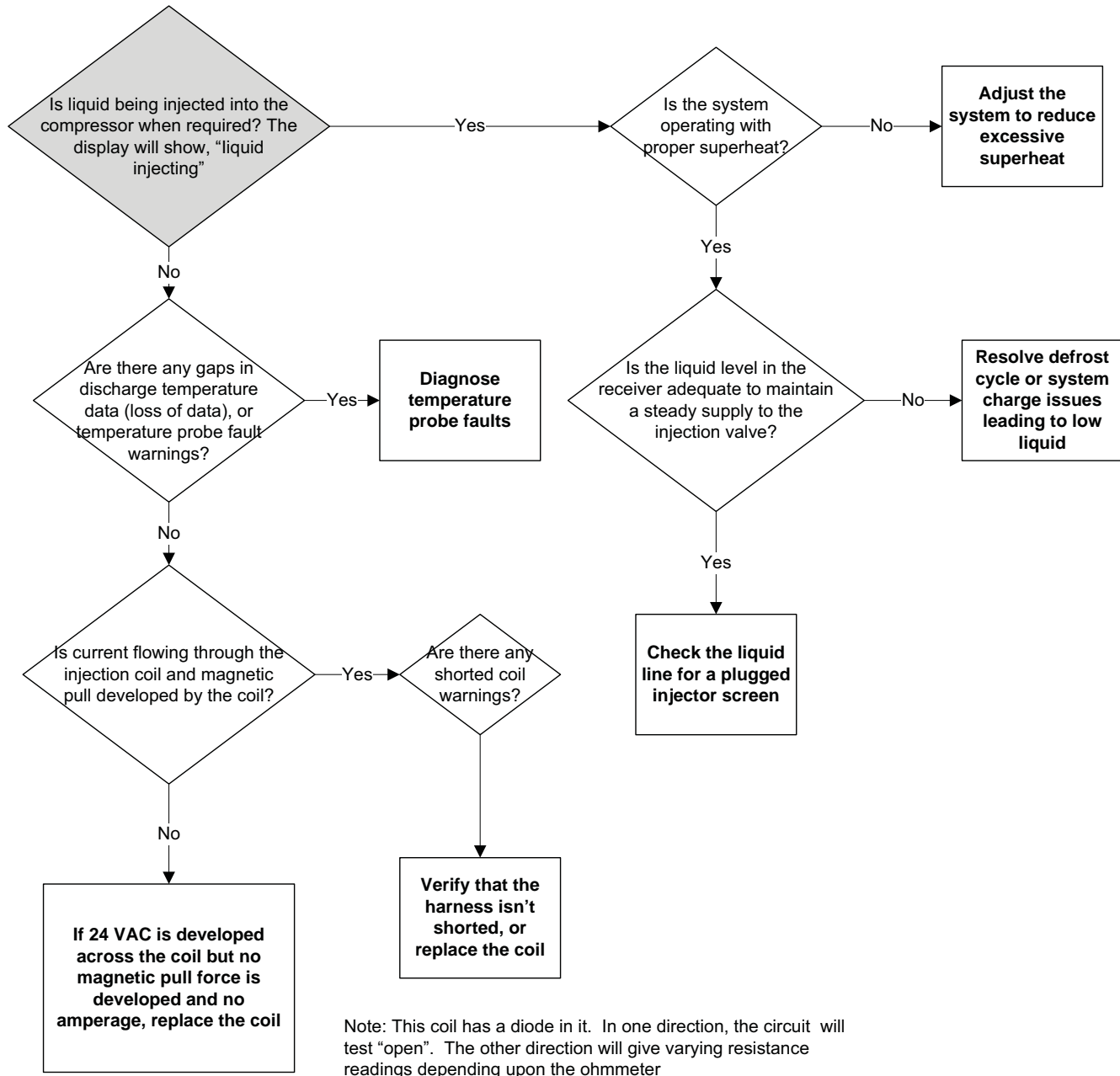

6.30

Current Overload Trip

This fault is a result of continuous compressor current that exceeds the configuration (MCC) limit by 10% for 60 seconds as determined by the current sensing transducer. This is independent of the compressor protector or motor temperature sensors.

The comp will auto-reset after 2 minutes (plus any remaining anti-short cycle time).

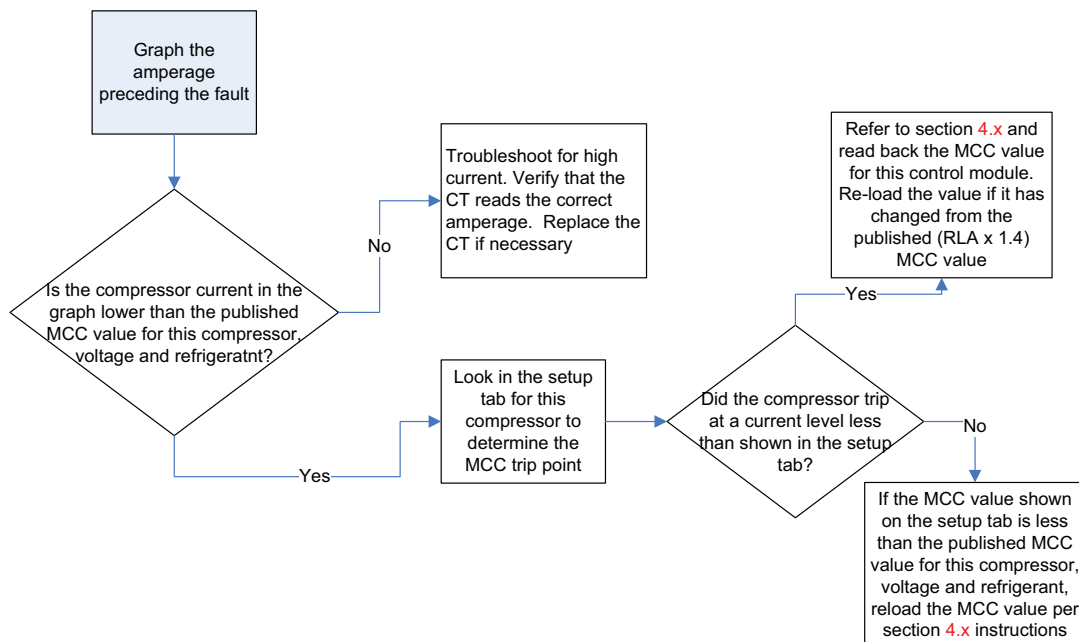
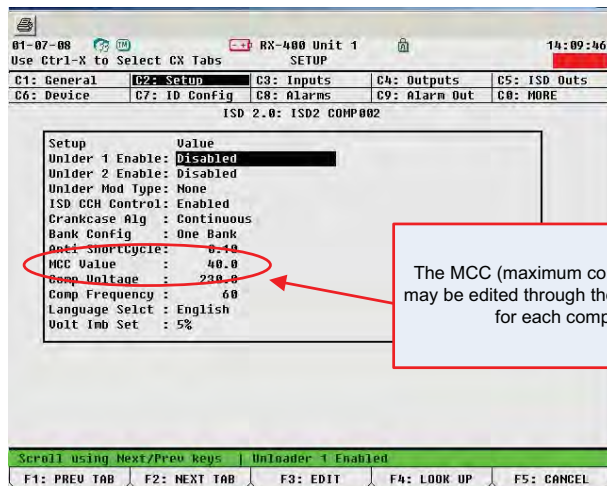

6.31

Rapid Compressor Cycling with Constant Demand; Contactor Chatter

Inspect for:

- Loose connection in the contactor coil power circuit
- Loose connection at the white sensor module connector that supplies 24V to the control module. Re-size the connector pin sockets or replace the harness. Reference 6.8 – Module Low Voltage Trip
- High pressure switch intermittent open circuit. Refer to 6.3, High Pressure Discharge Pressure Trip. After verifying that high head pressures are *not* the problem, temporarily bypass the pressure switch to see if the switch is the root cause.
- Undersized transformer. Reference the appendix for sizing of the transformer. This may occur if an unloader has been added to the compressor as an aftermarket upgrade.
- Auxiliary contactor miswired into the pilot circuit

6.32

Discharge Temperature Probe Fault Trip

This fault occurs when there is an “open” temperature probe circuit and the compressor is configured to run with Demand Cooling

Refer to 6.12, Fault Temperature probe, to resolve the temperature probe fault condition

6.33

Comp Low Voltage Trip / Lockout*

*This condition will result in a Lockout after 10 consecutive events

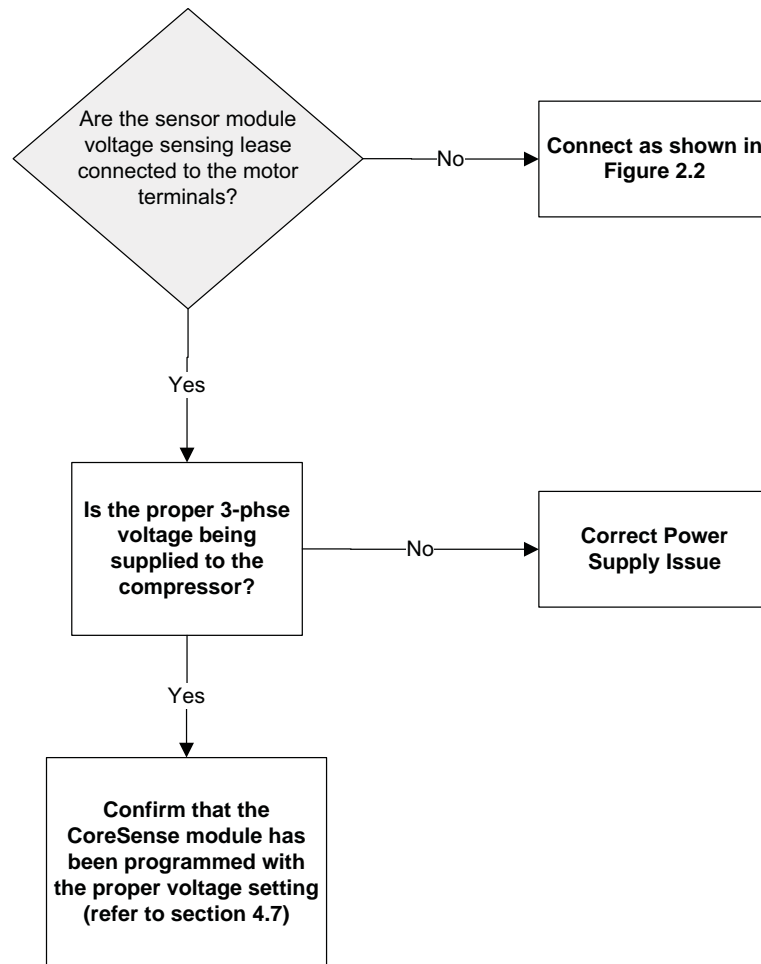

7.0 Service Instructions

7.1 Control Module Replacement

In the event of a control module failure, contact the Emerson Climate Technologies Wholesaler to obtain a replacement device. The last two digits of the part number (XX) designate the software version loaded into the module. The control module used for CoreSense Diagnostics v2.11 is universal for all 2D, 3D, 4D, and 6D compressors.

To perform the installation of the new control module follow these steps:

1. Remove power to the affected control module. Once power has been removed, both the LCD and LED display on the front of the module will be dark.
2. Access the control module electrical connections by removing the access cover at the bottom of the module.
3. Unplug all of the control module connections located on the bottom edge of the control module circuit board.
4. Remove the remaining four screws that secure the control module to the mounting plate.
5. Note the DIP switch settings. If the module was operating properly before failure, transfer those settings to the new control module. Otherwise refer to **Section 4.1** to determine the proper settings. The same can be said for both the controller and termination jumpers on the new control module.
6. Attach the new control module to the mounting plate using the four screws removed in step 4.
7. Make all harness connections removed in step number 3.
8. Apply power to the module. Once powered, the control module will display the DIP switch settings on the LCD. Verify that these settings are correct. With the proper DIP switch settings, the new module will be ready for normal operation. Refer to instruction sheet provided with the new control module for additional programming steps.
9. Using the provided packaging from the replacement module, return the failed unit to your Emerson Climate Technologies Wholesaler for a refund on your core charge or warranty replacement of the failed module.

7.2 Sensor Module Replacement

The CoreSense Diagnostics compressor sensor module relays information concerning the compressor current and voltage to the control module. If a failure would occur to the sensor module the control module would display "No Communications to Sensor Module". While the compressor would remain functional, enhanced motor protection features would be disabled. The features affected are:

- Locked Rotor Protection
- Welded Contactor Protection
- Voltage Imbalance Protection
- Low Voltage Protection

Basic compressor motor protection based on internal line break sensors (2D/3D) or PTC's (4D/6D) will still be present.

In the event of a sensor module failure, contact an Emerson Wholesaler to obtain a replacement device. There are two versions of the sensor module depending upon the application. Part number 543-0062-XX is the standard version of the sensor module used on compressors without part-winding start. Part number 543-0082-XX is the sensor module used on compressors with part-winding start. The last two digits of the part number (XX) designate the software version loaded into the module.

To perform the installation of the new control module follow these steps:

1. Remove power to the affected device. Be sure to switch power off to both the compressor and module. Always turn off compressor power before working on connections in the compressor terminal box. Once power has been removed, both the LCD and LED display on the sensor module will be dark. If the module in question is powering a crankcase heater, be sure that this power is switched as well.
2. Remove the terminal box cover to access the sensor module. The LED on the sensor module should be dark indicating that 24V power has been removed.
3. Disconnect all connections going to the sensor module. These connections include:
 - Compressor Voltage Sensors (x3)
 - Current Sensor (x2 if compressor is part-winding start)
 - Crankcase Heater Supply and Power (if present)

- 24VAC input power to the sensor module
 - 24VAC output power to the control module
4. Remove the two retaining nuts securing the sensor module to the terminal box and remove the module.
 5. Install the new module by reversing the steps listed above. When re-connecting the compressor voltage sensors be sure that the black lead is connected to the compressor terminal corresponding to the current sensor.
 6. Once the new module has been secured to the terminal box replace the terminal box cover and secure in place.
 7. Apply power to the compressor and module. Once the unit has been powered up the control module should display a message of Normal Running or Normal OFF.

7.3 Installation Torque Values

Component	Torque Value	
Control Module Mounting Screws	85-105	in*lb
Control Module Mounting Bracket Nuts	42-50	ft*lb
Sensor Module Mounting Nuts	26-31	in*lb
Pressure Cutouts (585-0125-03/-04)	95-108	in*lb
Pressure Cutouts (Other)	160-180	in*lb
Temperature Probe	170-200	in*lb
Current Sensor Mounting Nuts	26-31	in*lb
Motor Terminal Nuts	75-85	in*lb
Solenoid Valve Nuts/Bolts	42-50	ft*lb
Schrader Fittings (1/8" NPT)	120-180	in*lb

7.4 Demand Cooling Service Procedures

The demand cooling valve injects liquid refrigerant into the suction manifold to keep the discharge gas temperature within a safe operating range. Excessive discharge gas temperature will lead to ring and cylinder wear, valve wear and oil coking. Each Copeland Discus compressor with CoreSense Diagnostics has a temperature probe in the head to continually monitor the discharge gas temperature. The injection valve is energized when the temperature of the probe exceeds the "Injection Start" temperature. When the probe temperature drops below the "Injection Stop" temperature, the injection valve closes (is de-energized). Refer to **Table 7.0** for reference temperatures by model.

Note that the temperatures shown for 2D and 3D Copeland Discus compressors with CoreSense Diagnostics are lower than for standard demand cooling compressors. This is to compensate for the updated probe location used on the Copeland Discus compressors with CoreSense Diagnostics. **The actual peak gas temperatures inside the head are correspondingly higher and will be at the standard demand cooling levels** during injection start, injection stop and at the maximum trip temperature.

The following demand cooling service procedures are covered below:

- Temperature probe inspection
- Coil inspection and replacement
- Injection valve replacement

Table 7.0

Head Temperature (°F)	Standard Demand Cooling	2D/3D CoreSense Diagnostics	4D/6D CoreSense Diagnostics
Maximum (Trip)	310	290	310
Liquid Injection Start	292	276	282
Liquid Injection Stop	282	272	273

Table 7.1 Temperature Probe Resistance

Thermometer Temp. (F°)	Calculated Sensor Resistance (Ohms)	Thermometer Temp. (F°)	Calculated Sensor Resistance (Ohms)
59	141426	86	72504
60.8	135000	87.8	69480
62.6	128907	89.6	66609
64.4	123129	91.4	63864
66.2	117639	93.2	61254
68	112437	95	58770
69.8	107478	96.8	56394
71.6	102762	98.6	54126
73.4	98289	100.4	51966
75.2	94041	102.2	49914
77	90000	104	47943
78.8	86139	105.8	46053
80.6	82476	107.6	44262
82.4	78984	109.4	42543
84.2	75663		

7.5 Temperature Probe Inspection

Erroneous temperature probe readings may be due to “sprung” connections at the harness, or corrosion on the harness connector surfaces. A reading of approximately 0F and a display code of “Fault Temp Probe Trip” is indicative of an open circuit or poor electrical connection. Unplug the temperature probe from the harness and measure the probe resistance to determine whether the probe itself is faulty.

Refer to **Table 7.1** for expected resistance values based on probe temperature.

Plug the connector back in and look at the head temperature for this compressor on the E2 screen. Agreement between the calculated probe temperature based on resistance and the E2 temperature indicate the harness connection is good. An extreme temperature indicates the probe is faulty. A probe temperature based on resistance that seems reasonable based on the approximate temperature of the head indicates the probe itself is not faulty. If the E2 shows a head temperature that is obviously not correct, visually inspect the harness connector to look for signs of corrosion or for “sprung” female terminals in the harness. If the terminals appear to be “sprung”, carefully squeezing the outside of the plug to reconfigure their shape may yield acceptable contact. If the connections are not repairable, refer to **Appendix G** for a list of service replacement parts. Nyogel 760G lubricating grease is used in the connector to prevent fretting and corrosion.

7.6 Coil Inspection and Replacement

Refer to figures in **Appendix E** for the location of the injection coil. The coil may be removed by unplugging the harness from the coil and lifting the coil. Coils used on Copeland Discus compressors with CoreSense Diagnostics are 24VAC.

7.7 Injection Valve Replacement (4D and 6D) Reference Drawing of Enclosure and Accessories

Note: There are no unique injection valve service procedures for the 2D/3D Copeland Discus compressors with CoreSense Diagnostics. Use conventional 2D/3D valve change-out procedures and keep the torch flame away from the conduit wire harness to avoid damage.

1. Disconnect power to the compressor and module.
2. After isolating the liquid line by closing the shutoff, relieve trapped pressure by actuating the solenoid. **This is very important! When heated, pressures generated by trapped refrigerant may lead to a ruptured tube. Wear safety goggles when using**

a torch. Evacuate the compressor per accepted industry practice. Unsolder the injection tube from the liquid line. A wet rag around the valve is recommended for additional protection.

3. Unplug and remove the injection coil.
4. Loosen the flare fitting that attaches the injection valve to the compressor body (It may be necessary to remove the sheetmetal enclosure on the 6D compressor to gain access to this fitting.)
5. Install a new valve and torque the flare fitting to **15 ft-lb.**
6. Install the injection coil and reconnect the wiring harness.
7. Reconnect the liquid line to the new valve. Note that trimming the injection valve tube may damage the internal strainer. Emerson recommends that modifications not be made to the tube. Use the same flame precautions as in step 2.
8. Use approved refrigeration service procedures to evacuate the compressor and liquid line. Make certain that liquid is available to the injection valve by opening the supply valve.

8.0 Compressor Changeout Instructions

The following instructions assume that the same control module and sensor module will be used on the new compressor. If these modules are to be replaced, refer to **Section 7.0** of this document.

9.0 Removal of the Compressor (2D/3D)

1. Turn off power to the compressor, crankcase heater, and CoreSense Diagnostics modules.
2. Isolate the compressor and evacuate per accepted industry practice.
3. Inside the terminal box:
 - Remove compressor power terminal lugs
 - Disconnect/Unplug connections to the sensor module including:
 - voltage sensing leads
 - crankcase heater output
 - communication cable (to control module)
 - 24VAC power output (to control module)
 - Remove terminal box anchor screws holding the box to the compressor (4x)
4. Remove screws that secure wiring harness assembly to terminal box (2x)
5. Lift off terminal box.
6. Remove side cover screws to access pressure controls (2x)
7. Unplug leads to high and low pressure switch, temperature probe, and unloader (if present).

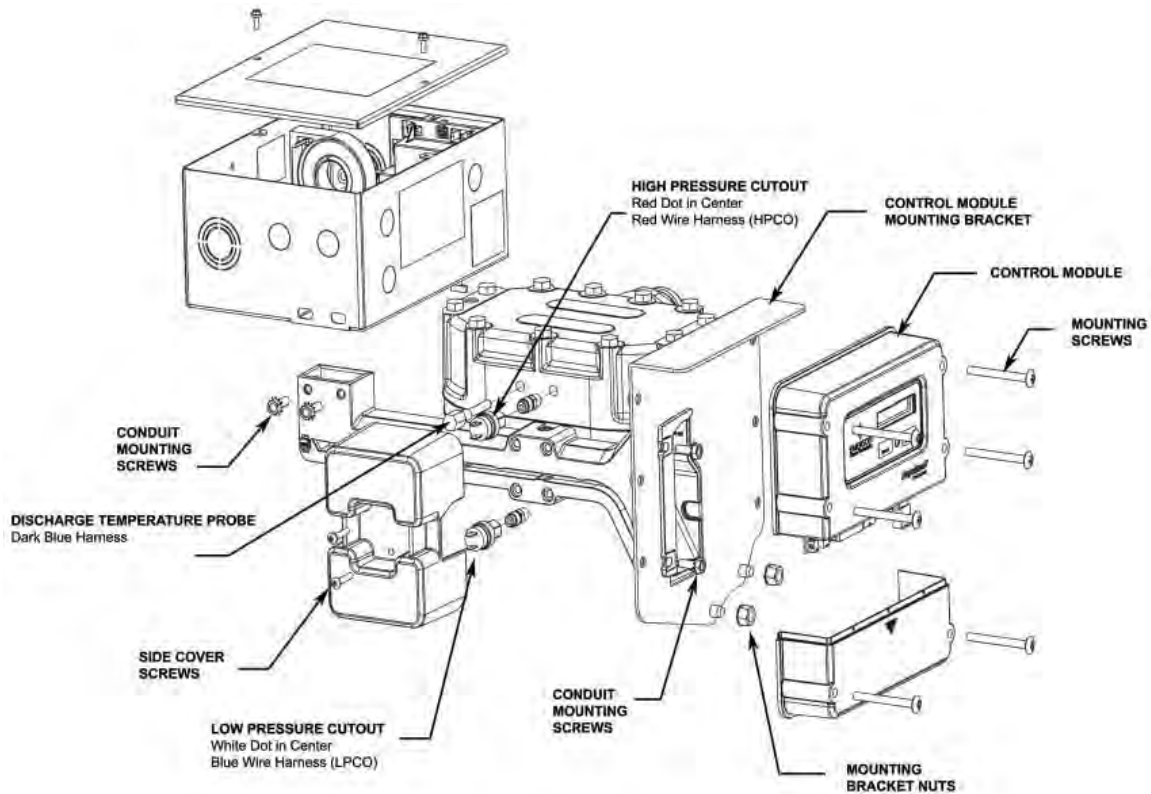

Figure 7.1
2D/3D CoreSense Diagnostics v2.11 Assembly Reference Drawing

8. Remove access cover on control module (two screws).
9. Unplug RS-485 communications plug.
10. Unplug the harness to the oil pressure switch.
11. Remove housing cover nuts securing control module mounting plate to compressor. (x2)
12. Remove control module and harness assembly as a unit by pulling it off towards the front of the compressor.
13. Remove the compressor from the rack using proper tools and procedures to assure safety, and to prevent damage to the rack or other compressors.

10.0 Installation of the compressor (2D/3D)

1. Mount the new compressor in the rack, lifting and maneuvering the compressor in a manner to prevent personal injury and damage to the other compressors on the rack.
2. Install the control module and harness assembly on the new compressor as a unit.
3. Install the housing cover nuts securing the control module mounting plate to the compressor. (x2)
4. Transfer the temperature sensor and pressure control fittings to the head and body of the new

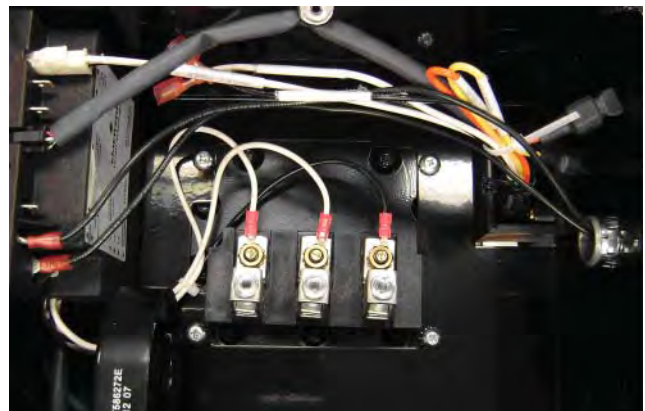

Figure 7.2 – 2D/3D Terminal Box Connections

- compressor. Use of a thread sealing compound is recommended. Connect temperature probe to wiring harness.
5. Install high pressure cutout switch (RED DOT - 360 psi) on the head, and low pressure cutout switch (WHITE DOT - 3 psi) on the compressor body. Double Check Positions! Connect pressure controls to wiring harness (HPCO-RED leads and LPCO-BLUE leads).

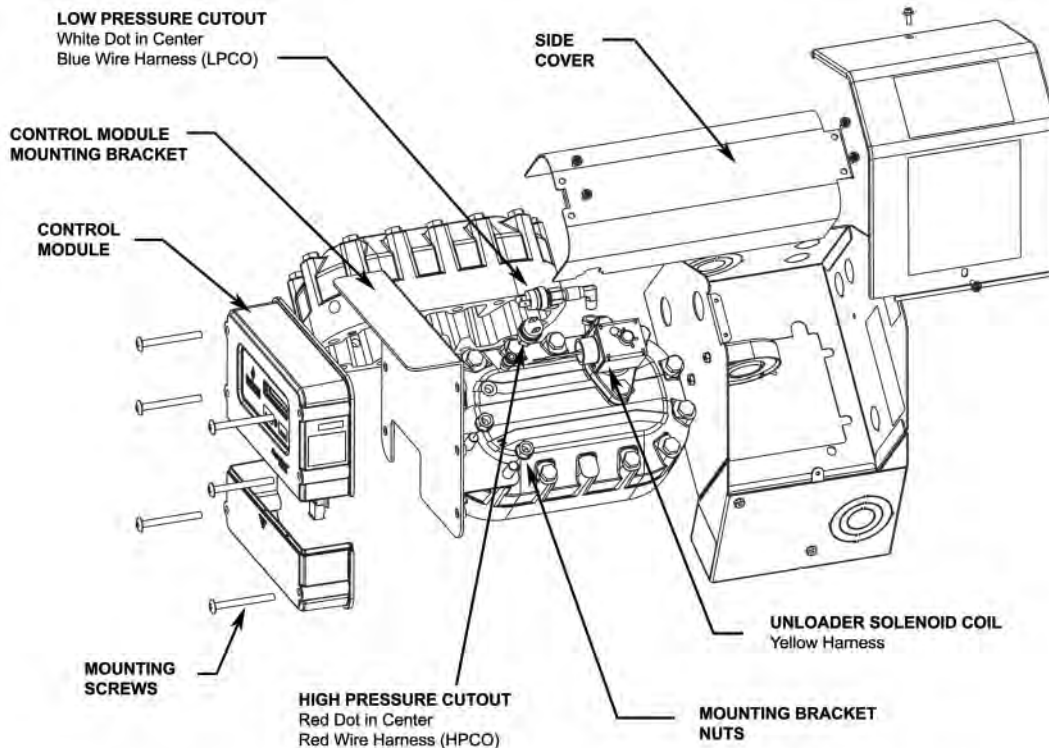

Figure 7.3
4D CoreSense Diagnostics v2.11 Assembly Reference Drawing

6. Install the terminal box on the compressor by routing the harness leads through the provided opening in the bottom of the box. Secure to the compressor using the four anchor screws.
7. Secure the wiring harness assembly to the terminal box by installing two screws.
8. Inside the terminal box:
 - Connect compressor power terminal lugs
 - Connect wires to the sensor module including:
 - voltage sensing leads
 - crankcase heater output
 - communication cable (to control module)
 - 24VAC power output (to control module)
9. Reconnect the RS-485 communications plug.
10. Reconnect the harness to the oil pressure sensor.
11. Replace the terminal box cover and secure with two screws.
12. Reinstall the side cover over the pressure controls.
13. Reinstall the control module access cover and secure with two screws.
14. Apply power to the compressor and CoreSense Diagnostics modules.

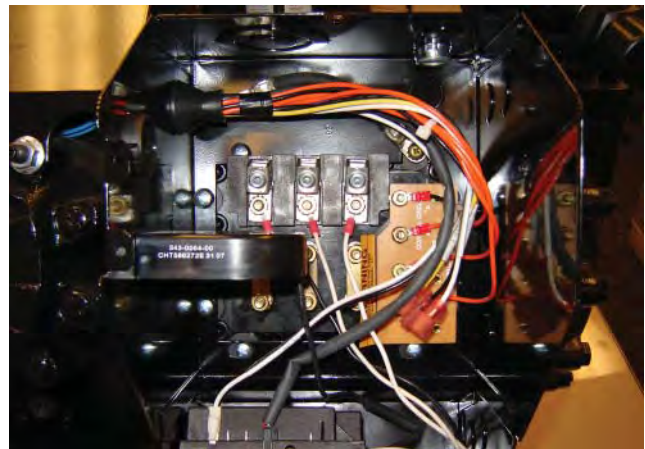

Figure 7.4 – 4D Terminal Box Connections

11.0 Removal of the Compressor (4D)

1. Turn off power to the compressor, crankcase heater, and CoreSense Diagnostics modules.
2. Isolate the compressor and evacuate per accepted industry practice.
3. Inside the terminal box
 - Remove compressor power terminal lugs

- Remove terminal box grounding strap
 - Remove the compressor motor sensor leads
 - Disconnect the compressor voltage sensing leads
 - Remove terminal box anchor screws holding the box to the compressor
4. Remove the side cover to access the high pressure control.
 5. Unplug leads to high and low pressure switches, temperature probe, and unloader (if present).
 6. Remove access cover on control module (two screws).
 7. unplug all harness connections at the control module.
 8. Unplug RS-485 communications plug.
 9. Unplug the harness to the oil pressure switch.
 10. Lift off terminal box with the wiring harness attached.
 11. Remove the two nuts securing the control module mounting bracket to the compressor
 12. Remove control module from the compressor.
 13. Remove the compressor from the rack using proper tools and procedures to assure safety, and to prevent damage to the rack or other compressors.

12.0 Installation of the Compressor (4D)

1. Mount the new compressor in the rack, lifting and maneuvering the compressor in a manner to prevent personal injury and damage to the other compressors on the rack.
2. Transfer the temperature sensor and pressure control fittings to the head and body of the new compressor. Use of a thread sealing compound is recommended.
3. Install high pressure cutout switch (RED DOT - 360 psi) on the head, and low pressure cutout switch (WHITE DOT - 3 psi) on the compressor body. Double Check Positions!
4. Install the terminal box on the compressor. Secure to the compressor using the four anchor screws.
5. Inside the terminal box
 - Connect compressor power terminal lugs
 - Connect terminal box grounding strap
 - Connect motor sensor leads
 - Connect the compressor voltage sensing leads
6. Install the control module mounting bracket on the compressor.

7. Reconnect the pressure controls to wiring harness (HPCO-RED leads and LPCO-BLUE leads).
8. Reconnect all plugs at the control module including the RS-485 communications plug.
9. Reconnect the harness to the oil pressure sensor.
10. Reconnect the harness to the head temperature probe and unloader (if present).
11. Reinstall the side cover and secure with four screws
12. Replace the terminal box cover and secure with two screws.
13. Reinstall the control module access cover and secure with two screws.
14. Apply power to the compressor and CoreSense Diagnostics modules.

13.0 Removal of the compressor (6D)

1. Turn off power to the compressor, crankcase heater, and CoreSense Diagnostics modules.
2. Isolate the compressor and evacuate per accepted industry practice.
3. Inside the terminal box
 - Remove compressor power terminal lugs
 - Remove terminal box grounding strap
 - Remove the compressor motor sensor leads.
 - Disconnect the compressor voltage sensing leads
 - Remove terminal box anchor screws holding the box to the compressor
4. Remove access cover on control module (two screws).
5. Unplug all harness connections at the control module including the RS-485 communications plug.
6. Disconnect the oil pressure and head temperature harness from the compressor.
7. Remove side cover and control module mounting nuts (6x).
8. Remove the side cover and control module as an assembly to access the high and low pressure controls.
9. Unplug leads to high and low pressure switches, and unloaders (if present).
10. Lift off terminal box with the wiring harness attached.
11. Remove the compressor from the rack using proper tools and procedures to assure safety, and to prevent damage to the rack or other compressors.

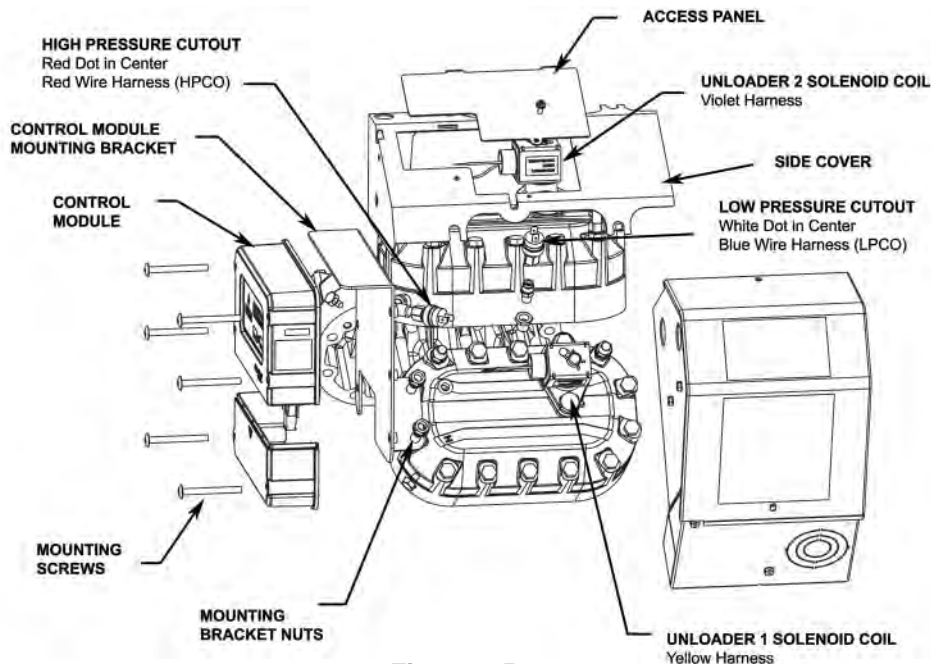

Figure 7.5
6D CoreSense Diagnostics v2.11 Assembly Reference Drawing

14.0 Installation of the compressor (6D)

1. Mount the new compressor in the rack, lifting and maneuvering the compressor in a manner to prevent personal injury and damage to the other compressors on the rack.
2. Transfer the temperature sensor and pressure control fittings to the head and body of the new compressor. Use of a thread sealing compound is recommended.
3. Install high pressure cutout switch (RED DOT - 360 psi) on the head, and low pressure cutout switch (WHITE DOT - 3 psi) on the compressor body. Double Check Positions!
4. Install the terminal box on the compressor. Secure to the compressor using the four anchor screws.
5. Inside the terminal box
 - Connect compressor power terminal lugs
 - Connect terminal box grounding strap
 - Connect motor sensor leads
 - Connect the compressor voltage sensing leads
6. Reconnect the pressure controls to wiring harness (HPCO-RED leads and LPCO-BLUE leads).
7. Reinstall the side cover and control module as an assembly. Fasten to compressor with mounting nuts (6x).

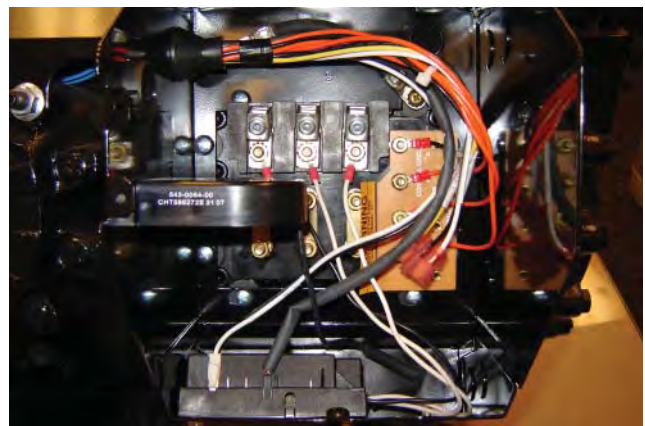
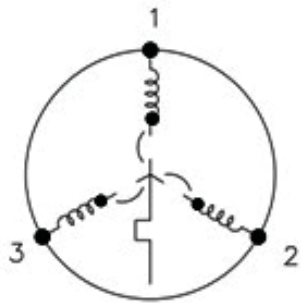

Figure 7.6 – 6D Terminal Box Connections

8. Reconnect all plugs at the control module including the RS-485 communications plug.
9. Reconnect the harness to the oil pressure sensor.
10. Reconnect the harness to the head temperature probe and unloaders (if present).
11. Replace the terminal box cover and secure with two screws.
12. Reinstall the control module access cover and secure with two screws.
13. Apply power to the compressor and CoreSense Diagnostics modules.

Appendix A

USE COPPER CONDUCTORS ONLY.
 USE THIS EQUIPMENT ON A GROUNDED SYSTEM ONLY.
 USE MINIMUM 75 °C WIRE FOR AMPACITY DETERMINATION.
 PRIMARY SINGLE PHASE FAILURE PROTECTION IS PROVIDED.
 INTERNAL MOTOR PROTECTION—ALLOW TIME FOR RESET.
 CRANKCASE HEATER, WHEN APPLIED, MUST BE CONNECTED ONLY TO ITS RATED VOLTAGE.
 OVERCURRENT PROTECTION DEVICE RATING AND TYPE MUST BE IN ACCORDANCE WITH REGULATORY AGENCY END PRODUCT APPROVALS—SEE SYSTEM NAMEPLATE.



MOTOR WINDING CONNECTIONS

LINE

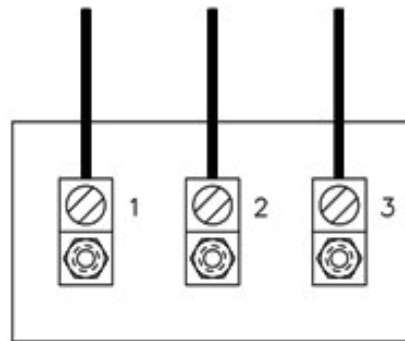

9-93 052-0837-00

ACROSS THE LINE CONNECTED

LINE VOLTAGE
400-460

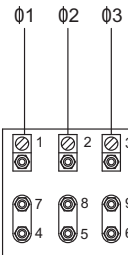

PART WINDING START CONNECTED

CONTROL CIRCUIT
VOLTAGE

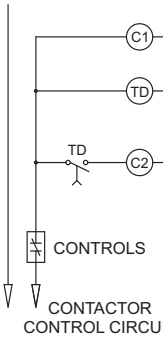

LINE VOLTAGE
200-240

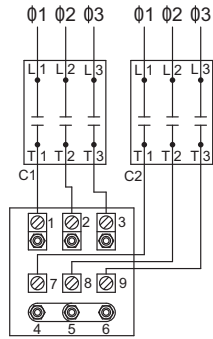

ACROSS THE LINE CONNECTED

LINE VOLTAGE
200-240

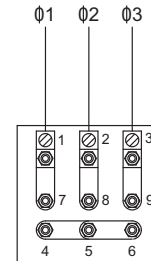

052-2435-00 02/09

WIRING DIAGRAM

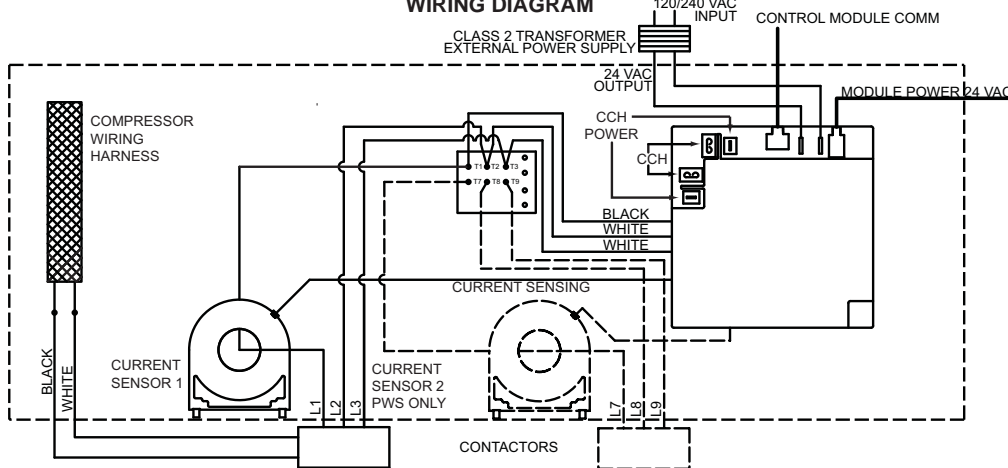

ELECTRICAL SYMBOL LEGEND

- CONTACTOR COIL
- NORMALLY OPEN TIME CLOSED CONTACT
- NORMALLY OPEN CONTACTOR CONTACTS
- MAX ONE SECOND TIME DELAY
- CONTROL CONTACTS SHOWN CLOSED

WHEN CHECKING MOTOR PROTECTION SYSTEM:

MODULE POWER MUST BE DISCONNECTED BEFORE CHECKING MOTOR SENSORS.

USE OHMMETER ONLY TO CHECK SENSOR RESISTANCE. DO NOT SHORT ACROSS THE TERMINALS.

SENSOR RESISTANCE MEASURED FROM TERMINALS (C TO S1,S2,S3) WITH MOTOR TEMPERATURE BELOW 60° C (140° F), SHOULD BE WITHIN THE FOLLOWING LIMITS: 30 TO 2400 OHMS. REFER TO EMERSON AE BULLETIN #10-1264.

USE COPPER CONDUCTORS ONLY.
USE MINIMUM 75° C (167° F) WIRE FOR AMPACITY DETERMINATION.
USE THIS EQUIPMENT ON A GROUNDED SYSTEM ONLY.
PRIMARY SINGLE PHASE FAILURE PROTECTION IS PROVIDED.
OPTIONAL CRANKCASE HEATER, FAN OR CAPACITY CONTROL VALVE(S) MUST BE CONNECTED ONLY TO THEIR RATED VOLTAGE.
OVERCURRENT PROTECTION DEVICE RATING AND TYPE MUST BE IN ACCORDANCE WITH REGULATORY AGENCY END PRODUCT APPROVALS - SEE SYSTEM NAMEPLATE.

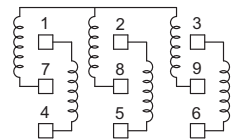

MOTOR WINDING CONNECTIONS

PART WINDING START CONNECTED

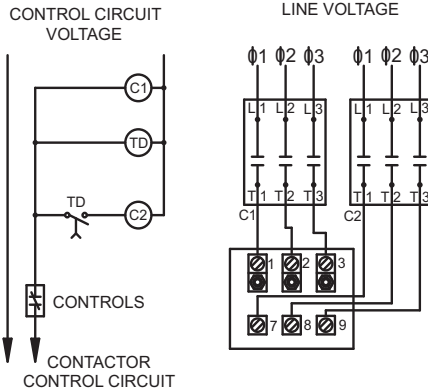

ACROSS THE LINE CONNECTED

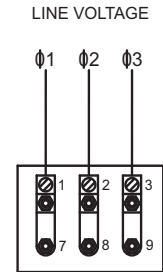

052-2436-00 02/09

WIRING DIAGRAM

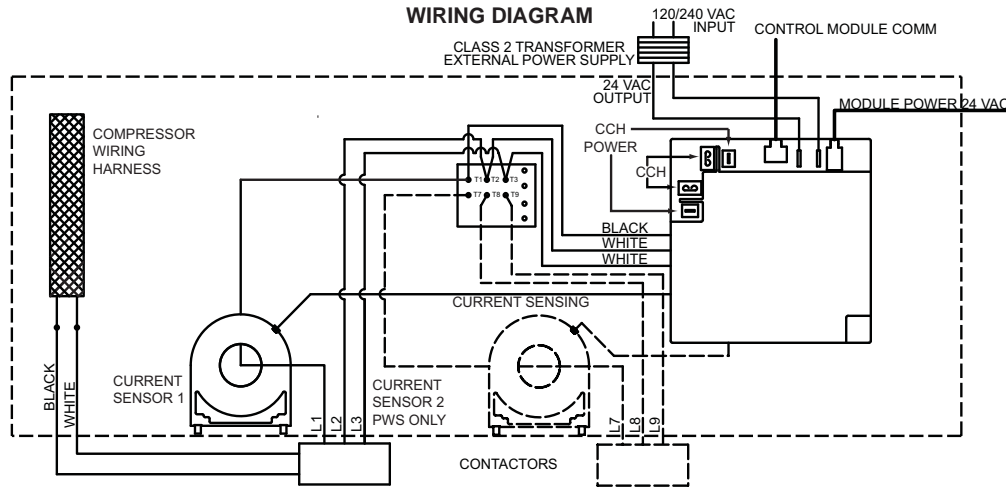

ELECTRICAL SYMBOL LEGEND

- CONTACTOR COIL
- NORMALLY OPEN TIME CLOSED CONTACT
- NORMALLY OPEN CONTACTOR CONTACTS
- MAX ONE SECOND TIME DELAY
- CONTROL CONTACTS SHOWN CLOSED

WHEN CHECKING MOTOR PROTECTION SYSTEM:

MODULE POWER MUST BE DISCONNECTED BEFORE CHECKING MOTOR SENSORS.
USE OHMMETER ONLY TO CHECK SENSOR RESISTANCE.
DO NOT SHORT ACROSS THE TERMINALS.
SENSOR RESISTANCE MEASURED FROM TERMINALS (C TO S1,S2,S3) WITH MOTOR TEMPERATURE BELOW 60° C (140° F), SHOULD BE WITHIN THE FOLLOWING LIMITS: 30 TO 2400 OHMS.
REFER TO EMERSON AE BULLETIN #10-1264.

USE COPPER CONDUCTORS ONLY.
USE MINIMUM 75° C (167° F) WIRE FOR AMPACITY DETERMINATION.
USE THIS EQUIPMENT ON A GROUNDED SYSTEM ONLY.
PRIMARY SINGLE PHASE FAILURE PROTECTION IS PROVIDED.
OPTIONAL CRANKCASE HEATER, FAN OR CAPACITY CONTROL VALVE(S) MUST BE CONNECTED ONLY TO THEIR RATED VOLTAGE.
OVERCURRENT PROTECTION DEVICE RATING AND TYPE MUST BE IN ACCORDANCE WITH REGULATORY AGENCY END PRODUCT APPROVALS - SEE SYSTEM NAMEPLATE.

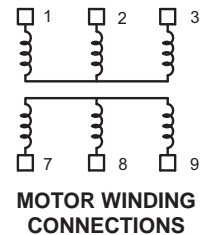

MOTOR WINDING CONNECTIONS

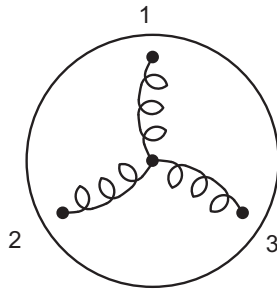

ACROSS THE LINE CONNECTED

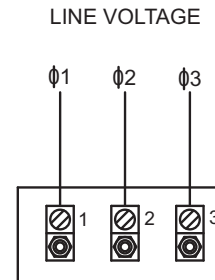

052-2437-00 02/09

WIRING DIAGRAM

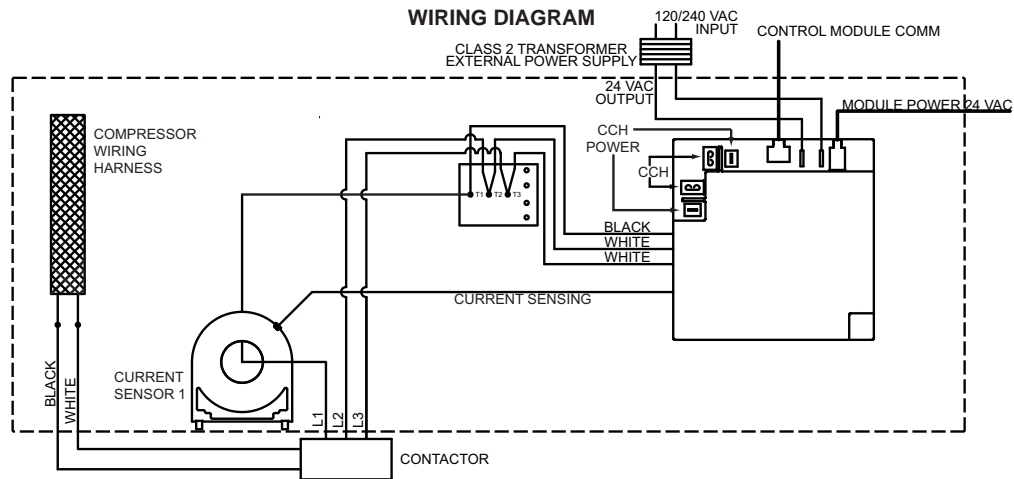

WHEN CHECKING MOTOR PROTECTION SYSTEM:

MODULE POWER MUST BE DISCONNECTED BEFORE CHECKING MOTOR SENSORS.

USE OHMMETER ONLY TO CHECK SENSOR RESISTANCE. DO NOT SHORT ACROSS THE TERMINALS.

SENSOR RESISTANCE MEASURED FROM TERMINALS (C TO S1,S2,S3) WITH MOTOR TEMPERATURE BELOW 60° C (140° F), SHOULD BE WITHIN THE FOLLOWING LIMITS: 30 TO 2400 OHMS. REFER TO EMERSON AE BULLETIN #10-1264.

USE COPPER CONDUCTORS ONLY.

USE MINIMUM 75° C (167° F) WIRE FOR AMPACITY DETERMINATION.

USE THIS EQUIPMENT ON A GROUNDED SYSTEM ONLY.

PRIMARY SINGLE PHASE FAILURE PROTECTION IS PROVIDED.

OPTIONAL CRANKCASE HEATER, FAN OR CAPACITY CONTROL VALVE(S) MUST BE CONNECTED ONLY TO THEIR RATED VOLTAGE.

OVERCURRENT PROTECTION DEVICE RATING AND TYPE MUST BE IN ACCORDANCE WITH REGULATORY AGENCY END PRODUCT APPROVALS - SEE SYSTEM NAMEPLATE.

USE COPPER CONDUCTORS ONLY.
 USE THIS EQUIPMENT ON A GROUNDED SYSTEM ONLY.
 USE MINIMUM 75 °C WIRE FOR AMPACITY DETERMINATION.
 PRIMARY SINGLE PHASE FAILURE PROTECTION IS PROVIDED.
 INTERNAL MOTOR PROTECTION—ALLOW TIME FOR RESET.
 CRANKCASE HEATER, WHEN APPLIED, MUST BE CONNECTED ONLY
 TO ITS RATED VOLTAGE.
 OVERCURRENT PROTECTION DEVICE RATING AND TYPE MUST BE IN
 ACCORDANCE WITH REGULATORY AGENCY END PRODUCT APPROVALS—
 SEE SYSTEM NAMEPLATE.

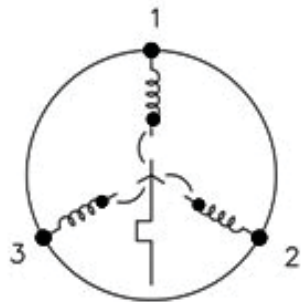

MOTOR WINDING CONNECTIONS

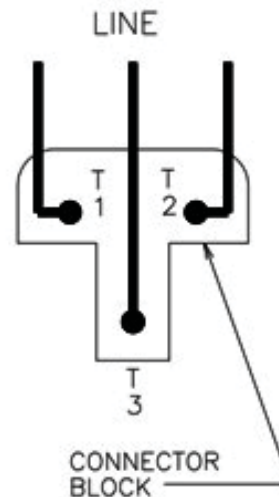

9-93 052-0803-00

USE COPPER CONDUCTORS ONLY.
USE THIS EQUIPMENT ON A GROUNDED SYSTEM ONLY.
USE MINIMUM 75 °C WIRE FOR AMPACITY DETERMINATION.
PRIMARY SINGLE PHASE FAILURE PROTECTION IS PROVIDED.
INTERNAL MOTOR PROTECTION—ALLOW TIME FOR RESET.
CRANKCASE HEATER, WHEN APPLIED, MUST BE CONNECTED ONLY TO ITS RATED VOLTAGE.
OVERCURRENT PROTECTION DEVICE RATING AND TYPE MUST BE IN ACCORDANCE WITH REGULATORY AGENCY END PRODUCT APPROVALS—SEE SYSTEM NAMEPLATE.

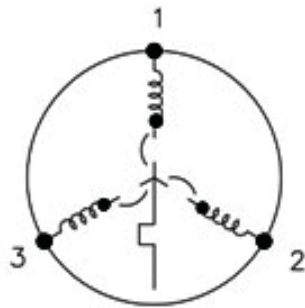

MOTOR WINDING CONNECTIONS

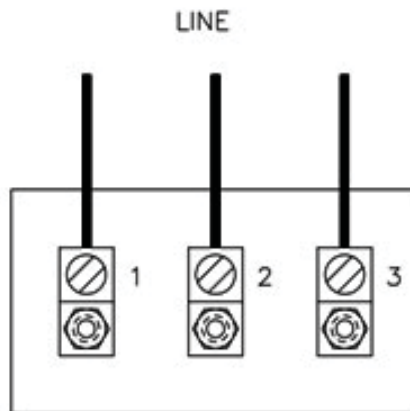

9-93 052-0837-00

Appendix B

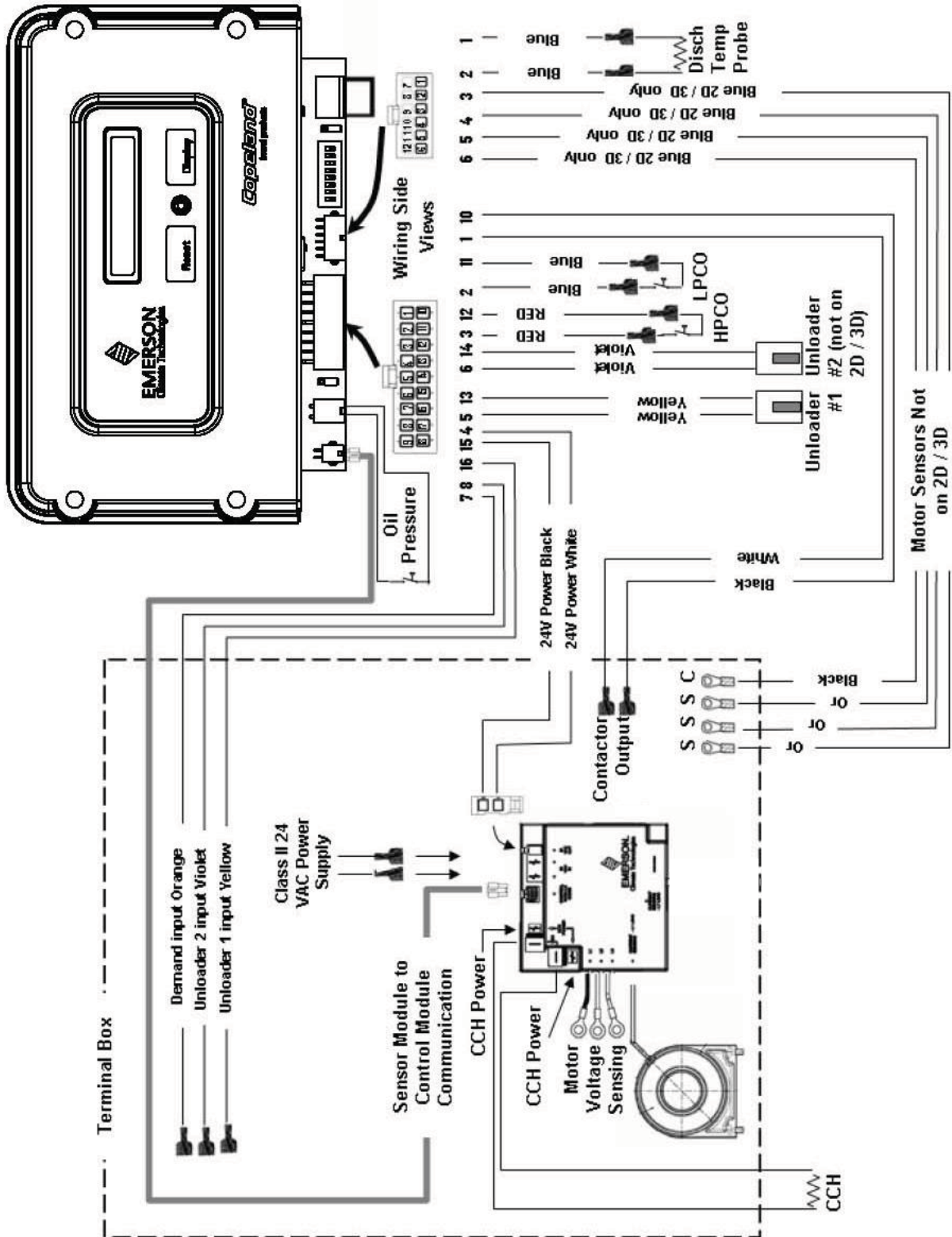

Appendix C

Transformer Selection And Contactor Control

Power requirements for controlling CoreSense Diagnostics v2.11 compressor operation must be provided by a Class 2 24VAC transformer. This voltage is used for powering the CoreSense Diagnostics v2.11 module, crankcase heater relay, unloaders, pilot duty relay or contactor coil. This voltage can be used for contactor coils providing the total load on the class 2 transformer does not exceed 100VA. When the loading on a class 2 transformer exceeds 100VA, it will be necessary to use a pilot duty relay which meets the electrical and mechanical characteristics to adequately carry the required loading. Transformer loading should be evaluated from both the Steady State/Continuous/Sealed, and Inrush VA's published by the manufacturer. It is recommended that pilot duty relays be used when NEMA contactors are specified for the compressor.

In selecting the VA of the class 2 transformer, the total load characteristics of the circuit must be evaluated. These are the total steady state, (sealed) VA, and the total inrush VA of all the devices the transformer will be operating at any given time. **Table C-1** shows the steady state and inrush VA's for devices such as: CoreSense Diagnostics v2.11 control and sensor modules, crankcase heater relay, pilot duty relay and unloader. If other devices than this are used, steady state and inrush VA must also be considered in the transformer selection. The device manufacturers should provide this information.

The 5 steps for selecting the transformer are:

1. Determine your primary and secondary voltage requirements, as well as the supply frequency i.e. 60hz, 50 hz.
2. Determine the inrush and sealed VA of all components (including lights, etc.) that might be in the circuit.
3. Determine the sum of all sealed VA values.
4. Determine the transformer total inrush VA by summing the component sealed VA and inrush VA.

$$\text{Total Inrush VA} = \Sigma \text{ Sealed VA} + \Sigma \text{ Inrush VA}$$
5. Take the sealed VA value from step (3) and the total inrush value from step (4). Refer to the transformer regulation table, using the 95% secondary voltage with a 40% power factor. Select a nameplate VA rating that satisfies both the sealed VA and the total inrush VA of the transformer.

**Table C-1
(Device Inrush And Sealed VA's)**

Device	VA Inrush	VA Sealed
CoreSense Diagnostics Modules	3.78	3.78
Crankcase Heater Relay	.96	.96
**Pilot Duty Relay	24	10
*Unloader (One)	37.4	18

*6D compressors may use 2 unloaders

** Stancor Type 91 Relay PN 91-901

Table C-2 shows the recommended class 2 transformer for individual compressor models for CoreSense Diagnostics v2.11 applications when a pilot duty relay is used.

**Table C-2
(Recommended Minimum Class 2 Transformers for Compressor Models
Using a Stancor Pilot Duty Relay)**

Class 2 Transformer Size			
Model	VA Inrush	VA Sealed	CoreSense Diagnostics v2.11 With Pilot Duty Relay
2D	27.78	13.78	40VA
3D No Unloader	27.28	13.78	40VA
3D One Unloader	65.18	31.78	40VA
4D No Unloader	27.78	13.78	40VA
4D One Unloader	65.18	31.78	40VA
6D No Unloader	27.78	13.78	40VA
6D One Unloader	65.18	31.78	40VA
*6D Two Unloaders	102.58	49.78	75VA

Example of transformer size calculation:

Using **Formula A**, transformer regulation **Table C-5**, and a 3D compressor with one unloader, calculate the total inrush VA and steady state VA for devices that will be powered. Refer to **Table C3** for VA values. This compressor will have inrush and sealed VA's for the following devices:

Table C-3

	Inrush VA	Sealed VA
CoreSense Diagnostics Modules	3.78 VA	3.78 VA
Pilot Duty Relay	24 VA	10 VA
One Unloader	37.4 VA	18 VA
Total Inrush VA	65.18 VA	31.78 VA

Formula A

TOTAL INRUSH VA = Σ VA sealed + Σ VA inrush

TOTAL INRUSH = 96.96 VA (This is the value used for inrush @ 40% PF and 95% secondary voltage)

Next, refer to the transformer regulation **Table C-5**, and select a transformer for the total sealed VA. This is a 40VA transformer. Using the column 95% secondary column ensure that the inrush VA is greater than that calculated above, (72.5 VA). As seen from this transformer regulation table, a 40VA transformer is sufficient to handle the calculated sealed VA as well as the total inrush VA.

NOTE: The transformer regulation table shown here is just a guide for these calculation. The transformer manufacturer can supply a specific transformer regulation table for their product and should be used in determining transformer size.

Example of transformer size calculation when contactor is directly powered by the class 2 transformer:

Again, use the same 3D example with one unloader, calculate the total inrush VA and steady state VA for devices that will be powered. Refer to **Table C-4** for VA values. The contactor selected for this example is a Square D NEMA size 00. The contactor specification indicates 33 VA sealed and 165 VA inrush. Direct control eliminates the use of a pilot duty

Table C-4

	Inrush VA	Sealed VA
CoreSense Diagnostics Modules	3.78 VA	3.78 VA
One Unloader	37.4 VA	18 VA
Nema 00 Contactor	165 VA	33 VA
Total VA	206.18 VA	54.78 Va

Formula A

TOTAL INRUSH VA = Σ VA sealed + Σ VA inrush

TOTAL INRUSH VA = 260.96 VA (Use this inrush value for transformer selection)

From transformer regulation **Table C-5**, select a transformer greater than the sealed VA of 54.78 VA. This would be a 60 VA transformer and the inrush is 250 VA, which is greater than the 206.18 calculated above. We would therefore select a 75 VA transformer from this table to satisfy the sealed and inrush VA's for this example.

When contactors are powered directly by the class 2 transformer, it is essential to use the manufacturer inrush and sealed VA values for the selected contactor because these can vary by a significant amount. This is true when using a Definite Purpose Contactor or a NEMA style contactor from different manufacturers.

Keep in mind, you cannot exceed 100VA sealed and stay within the UL guidelines for class 2 circuits. A wire size **Table C-6** is also provided as a reference, actual wire size specified must conform to local and NEC (National Electrical Code)

Transformer Regulation Table C-5
(Consult Transformer Manufacturer For The Particular Product/Brand)
24 VAC Class 2 Transformer Data

Transformer Regulation Data		
Stancor/White Rodgers Part Number	Continuous VA Transformer Nameplate	Inrush VA @ 40% Power Factor 95% Secondary Voltage
T40-24F3 / 90-T40F3	40	160
T50-24C3 / 90-T50C3	50	205
T60-24C3 / 90-T60C3	60	250
T75-24C3 / 90-T75C3	75	325
T100-24C2 / 90-T100C2	100	450

Example Of Determining Wire Length:

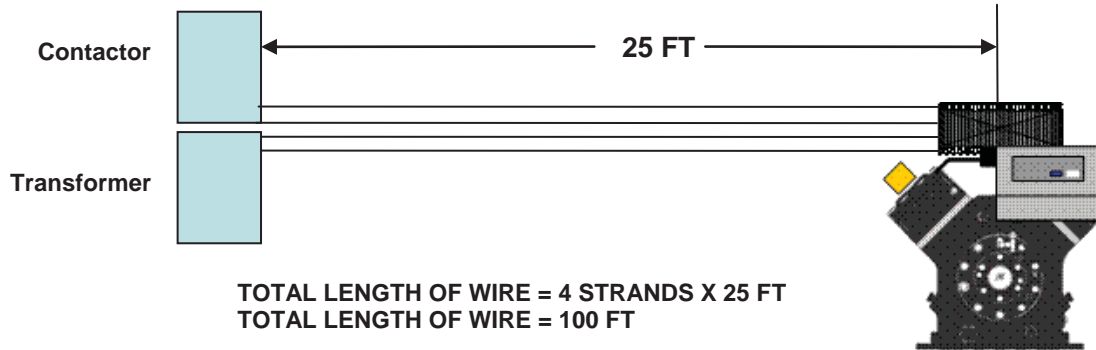

Table C-6
Wire Sizing

Recommended Secondary (24V) Minimum American Wire Size (AWG) These Sizes Will Keep Voltage Drops To Less Than One Volt With XFMR Producing Rated Current				
Continuous VA XFMR Nameplate	25 Linear Ft. Wire Size AWG	50 Linear Ft. Wire Size AWG	75 Linear Ft. Wire Size AWG	100 Linear Ft. Wire Size AWG
40	18	18	18	14
50	18	18	16	14
60	18	18	16	14
75	18	16	16	12
100	18	16	14	12

- Wire size shown in this table is suggested when contactor coil is powered by the 24 volt CoreSense Diagnostics v2.11 module.

NOTE: For reliability, Emerson recommends that the temperature class of the transformer be a minimum of CLASS B (130 degrees C) (Ambient + Internal Temperature) In addition, it is recommended that Inrush VA at 40% power factor use the 95% Secondary voltage. This accounts for a 10% variance in the supply voltage. If at all possible, the primary transformer should be wired for 208/230 volts or higher to reduce voltage droop on the secondary due to higher currents and resulting voltage drops. Adequate ventilation is required to ensure that ambient and internal temperatures do not exceed the temperature class of the transformer, and that sufficient mounting hardware be used to support the weight.

Pilot Duty Relays:

Relays are available in many sizes and configurations having high mechanical and electrical reliability along with manageable cost. Like transformers, relays are sized according to their Steady State/Continuous and Inrush VA's published by the manufacturer.

Some of the benefits of using a pilot duty relay would be lower transformer cost due to lower VA and system wire size. Care should be given to NEMA style contactors with 24V coils because total VA can be exceeded in class 2 circuits quickly because of the high inrush VA and sealed VA associated with them. Pilot duty relays can be advantageous in these situations by transferring system voltage and current to these higher power devices. It is recommended that a pilot duty relay be used with any NEMA contactor.

Relays such as Stancor 91-901 DPDT or 184-912 SPNO have been used with success in applications where transformer loading exceeded 100VA and a pilot duty relay was required.

Wiring schematic showing the use of a pilot duty relay to control contactor with system voltage and/or 24 volt direct control of contactor from CoreSense Diagnostics v2.11 module:

Figure C-1
Using Pilot Duty Relay
for Contactor Coil

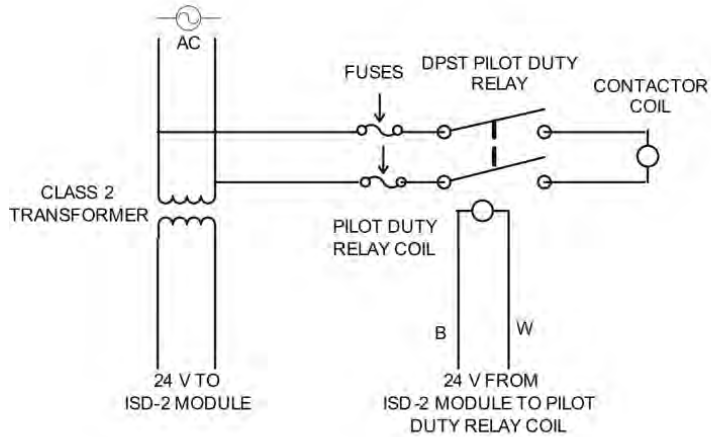
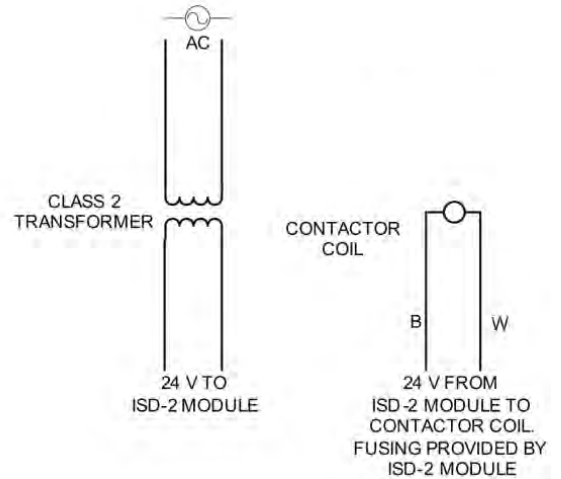

Figure C-2
Using Direct 24 Volt Control
for Contactor Coil



Appendix D

Dielectric Test (Hi-Pot), Megger, of Copeland Discus Compressors with CoreSense Diagnostics Fitted with Sensors and Control Module. (4 & 6 D Models)

WARNING:

Performing Hi Voltage test to a compressor must be performed by an experienced and qualified individual. Hi Voltage is dangerous and could result in severe damage to equipment, personal injuries, or death. Follow all specifications, local and national codes, and procedures when performing Hi Voltage test.

Steps to follow:

1. Ensure power to compressor and other associated electrical devices is off.
2. Ensure that compressor body is grounded.
3. Ensure that compressor is not in a vacuum.
4. Inside the compressor terminal box, remove the (4) sensor leads from the sensor terminalboard. (1 black and 3 orange) insulate the terminals on these 4 leads to prevent accidental contact with Hi Voltage.
5. Short the (4) sensor terminal post and connect to a good ground.
6. Apply the proper Hi Pot Voltage from each of the motor power terminals to ground. Never apply Hi Pot Voltage across motor power terminals.

For compressors using line break protection, (2 & 3D), follow steps 1, 2, 3, & 6 above.

Appendix E 2D Drawing With Demand Cooling

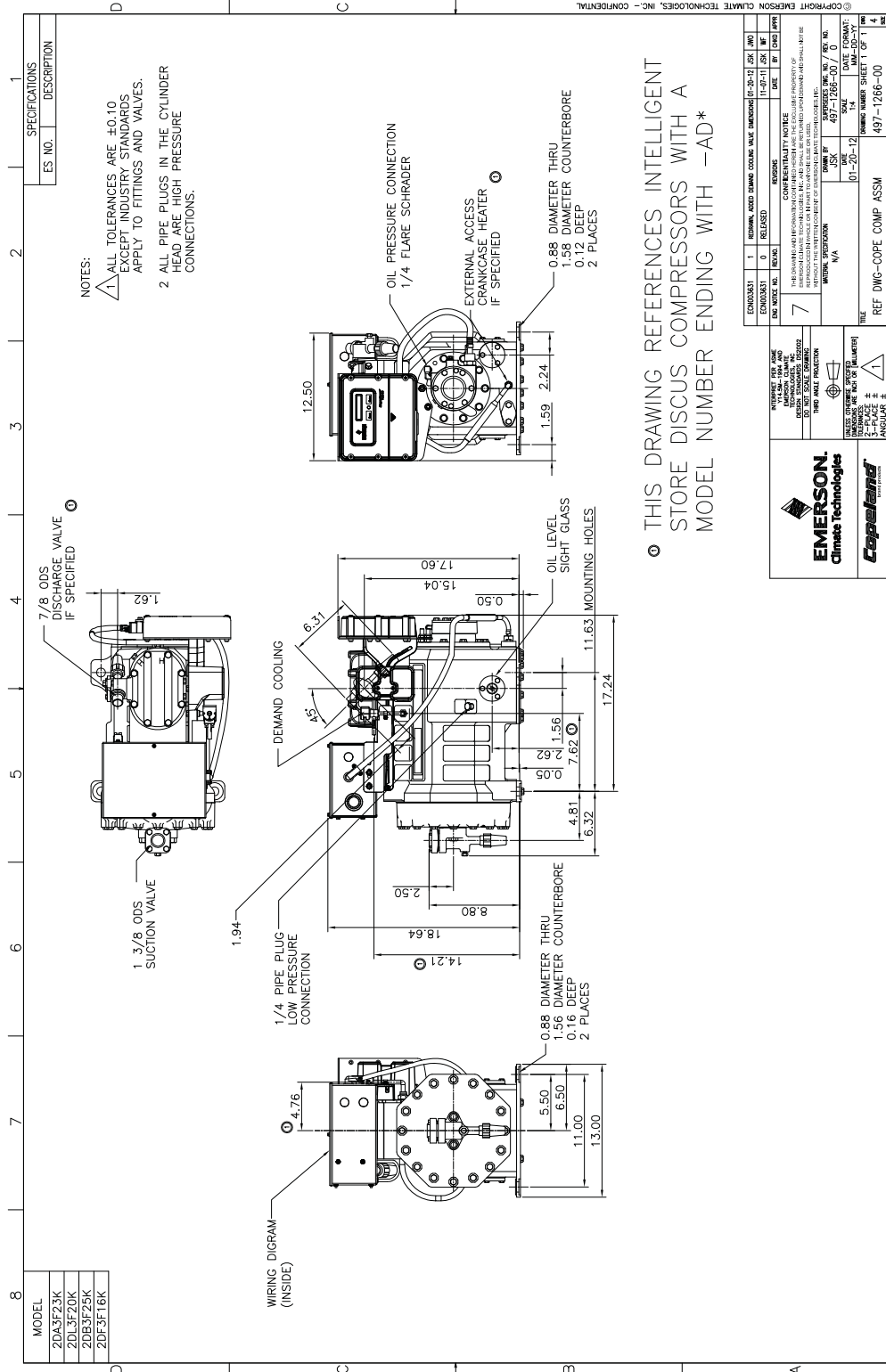

4D Drawing With Demand Cooling

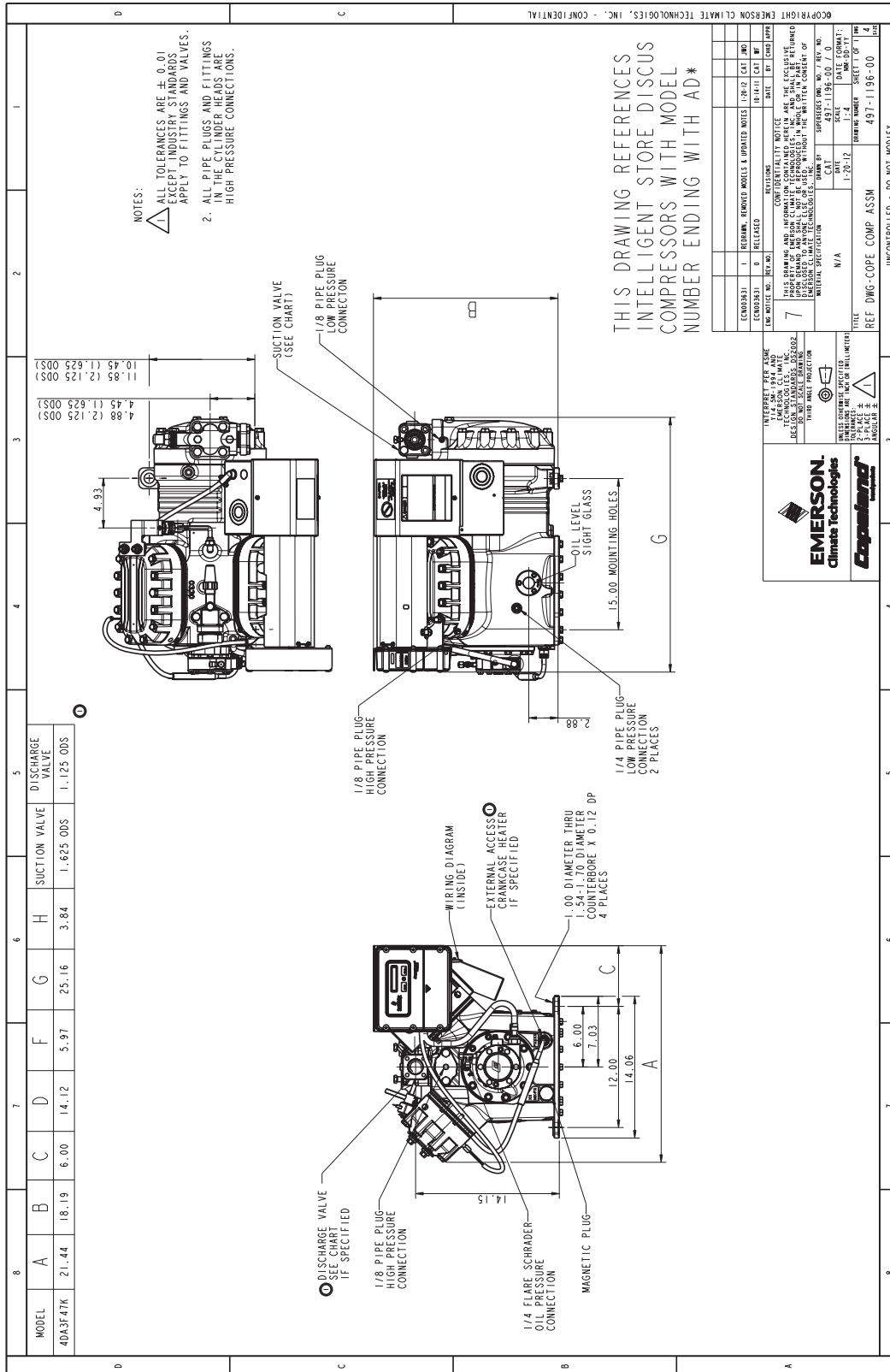

6D Drawing With Demand Cooling

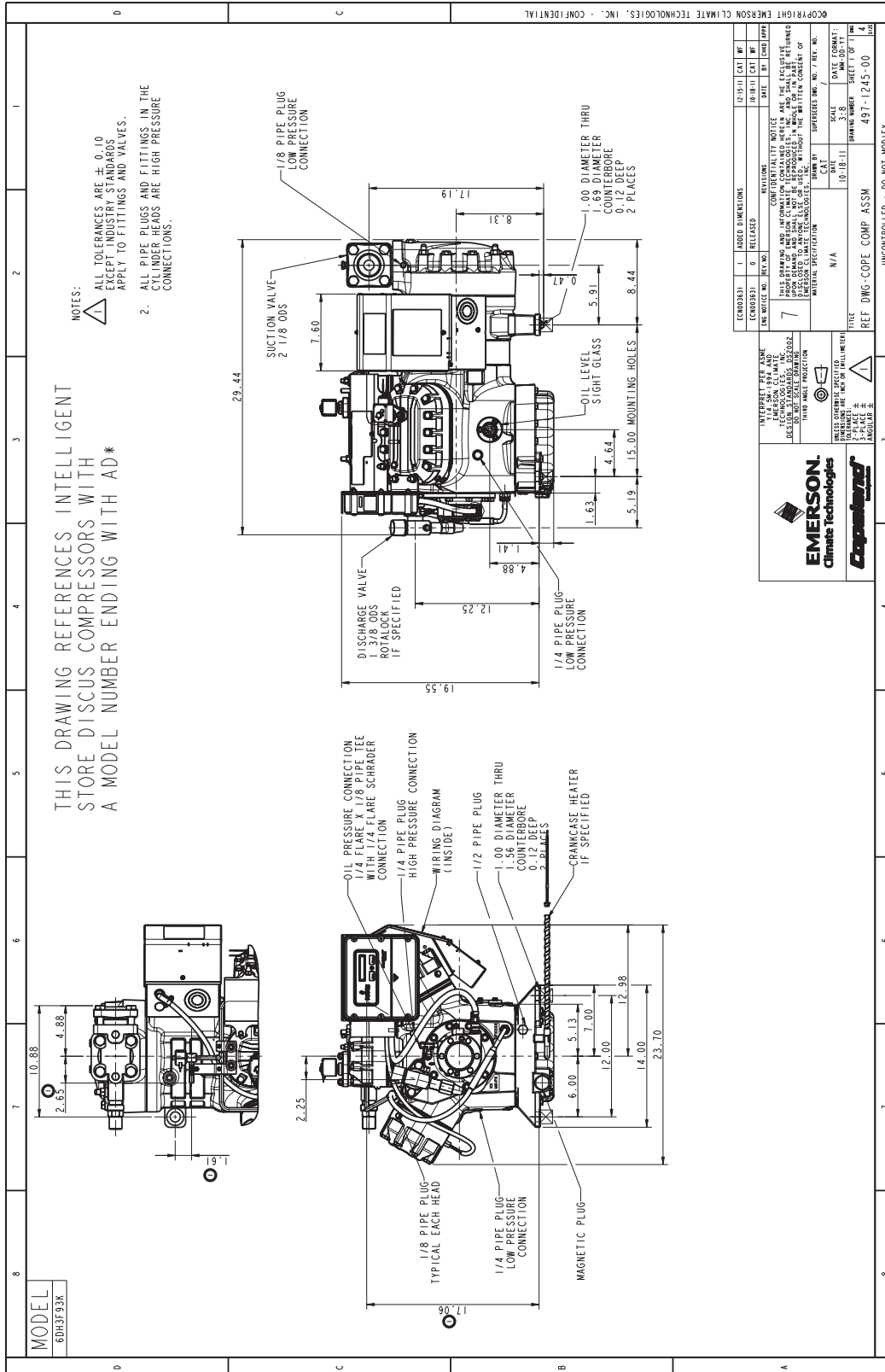

2D Compressor Drawing

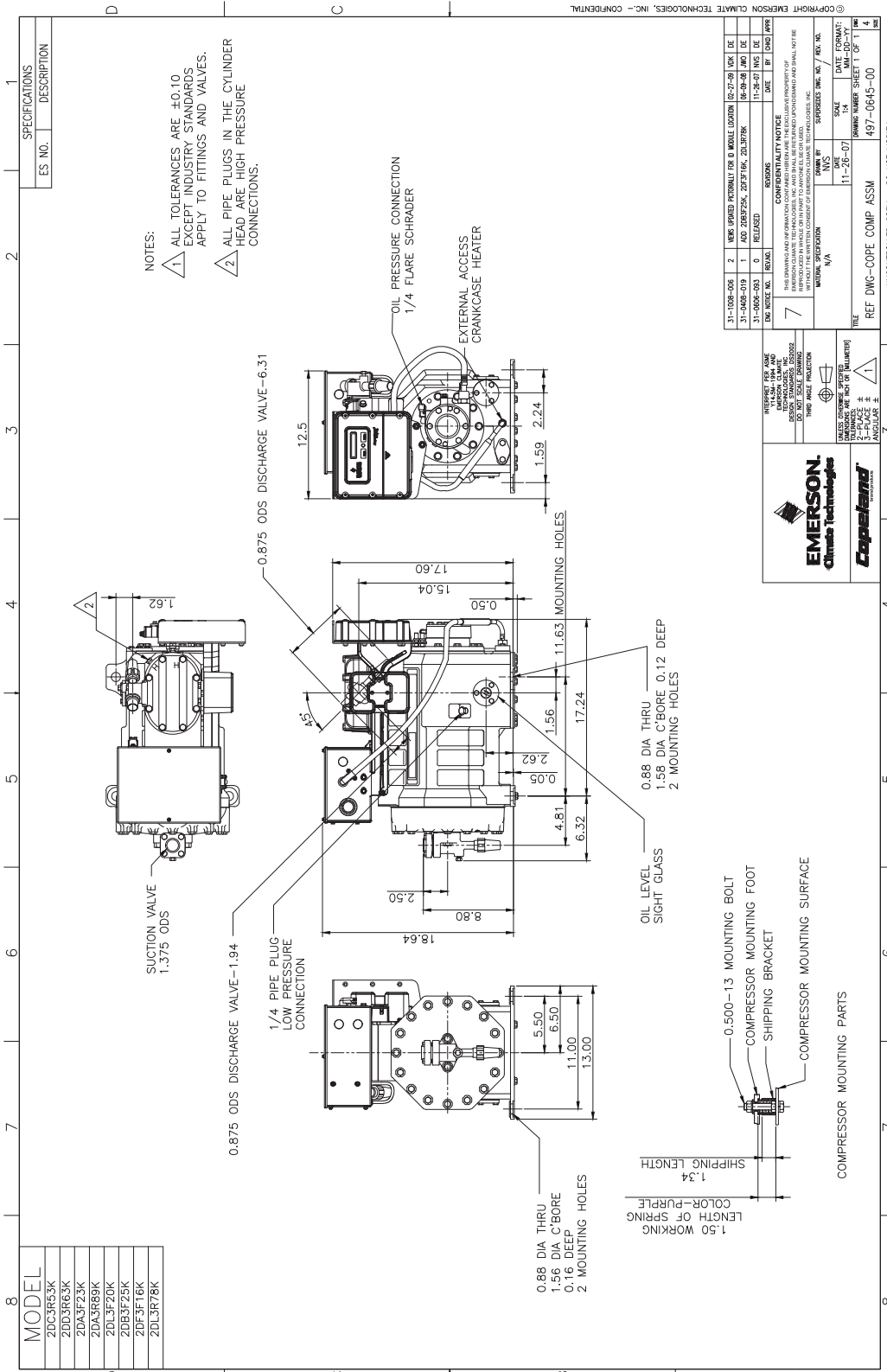

ES NO.	DESCRIPTION
1	SPECIFICATIONS
2	WORK SHIPMENT FOR B. WOLFE LOCATION (02-07-00) VOK DE
3	ADD 2083F25K, 203F78K, 20L3R78K (06-09-00) VOK DE
4	RELEASED (11-26-07) NWS DE
5	DATE BY (10/01/07)
6	DATE BY (10/01/07)
7	DATE BY (10/01/07)

REVISIONS

REV	DATE	BY	DESCRIPTION
1	11-26-07	NWS	ADD 2083F25K, 203F78K, 20L3R78K
2	11-26-07	NWS	RELEASED

CONFIDENTIALITY NOTICE:
THIS DRAWING AND INFORMATION CONTAINED HEREIN ARE THE PROPERTY OF EMERSON CLIMATE TECHNOLOGIES, INC. AND SHALL BE RETURNED UPON REQUEST AND SHALL NOT BE REPRODUCED OR TRANSMITTED IN ANY FORM OR BY ANY MEANS, WITHOUT THE WRITTEN PERMISSION OF EMERSON CLIMATE TECHNOLOGIES, INC.

EMERSON Climate Technologies
Copeland

DATE: 11-26-07
SCALE:
DATE: 11-26-07
DATE: 11-26-07
DATE: 11-26-07

REF DWG-COPE COMP ASSM 497-0845-00

UNCONTROLLED COPY - DO NOT MODIFY

3D Compressor Drawing

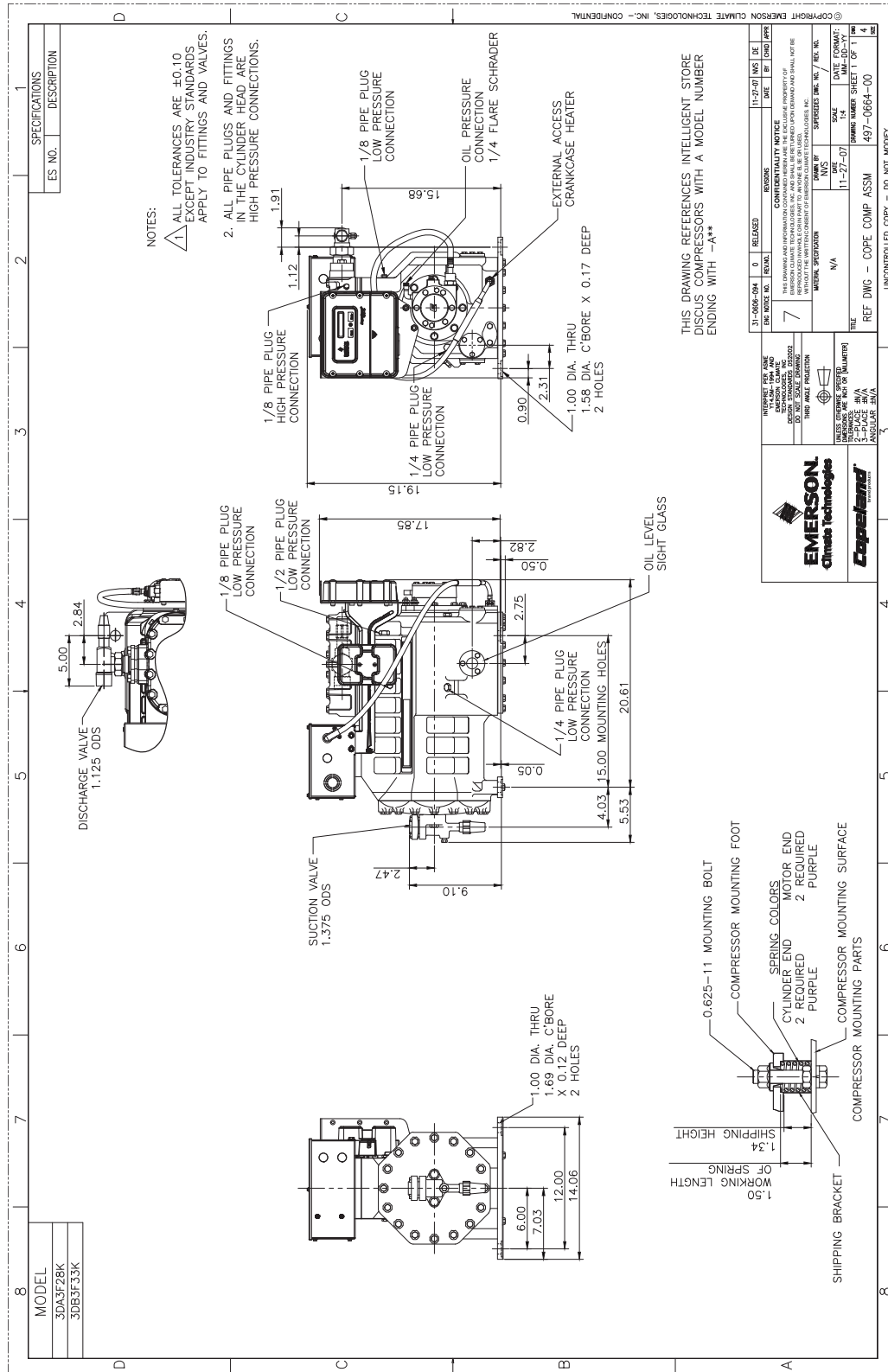

4D Compressor Drawing

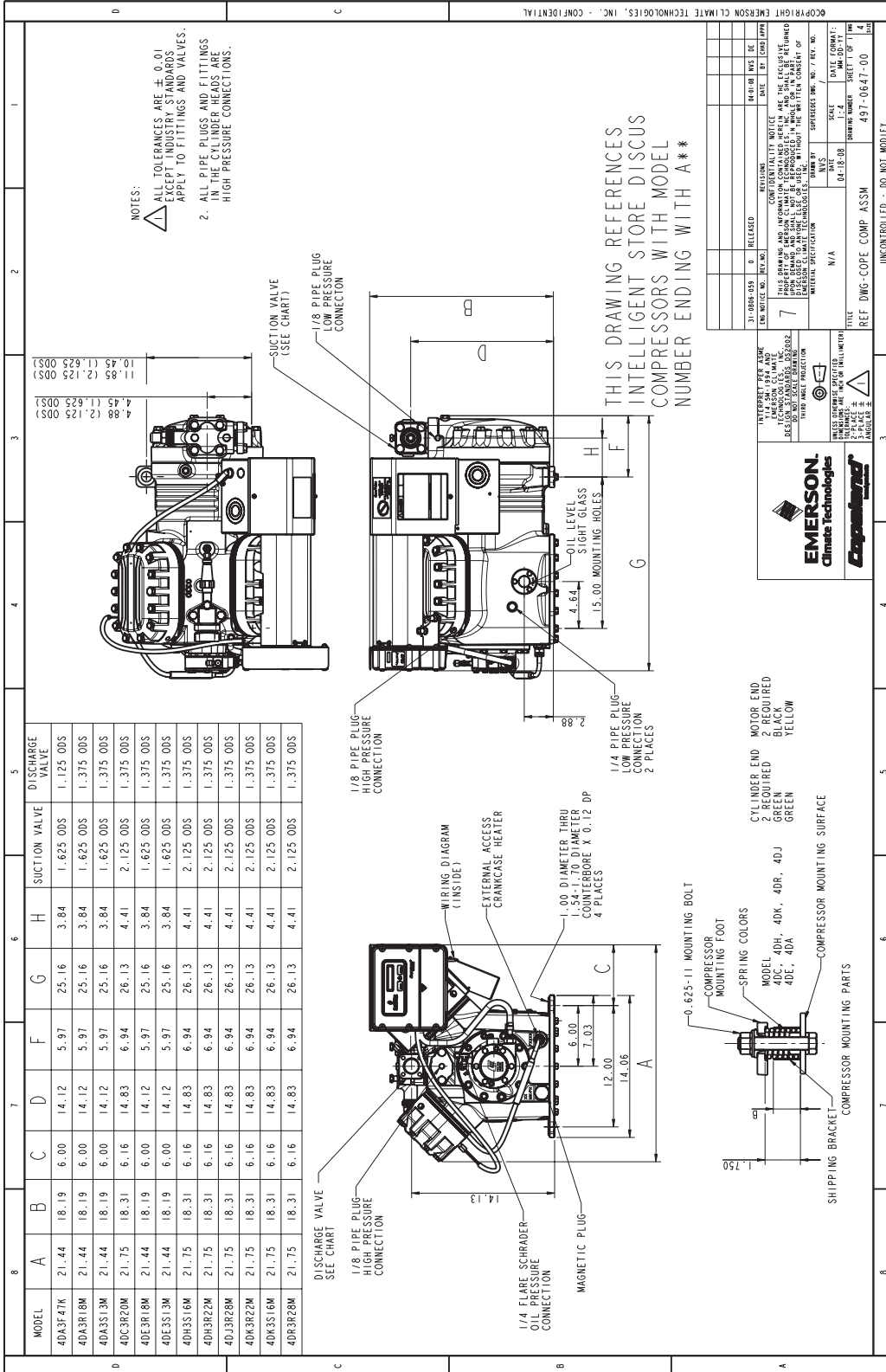

BULLETIN

AE8-1368 R2

6D Compressor Drawing

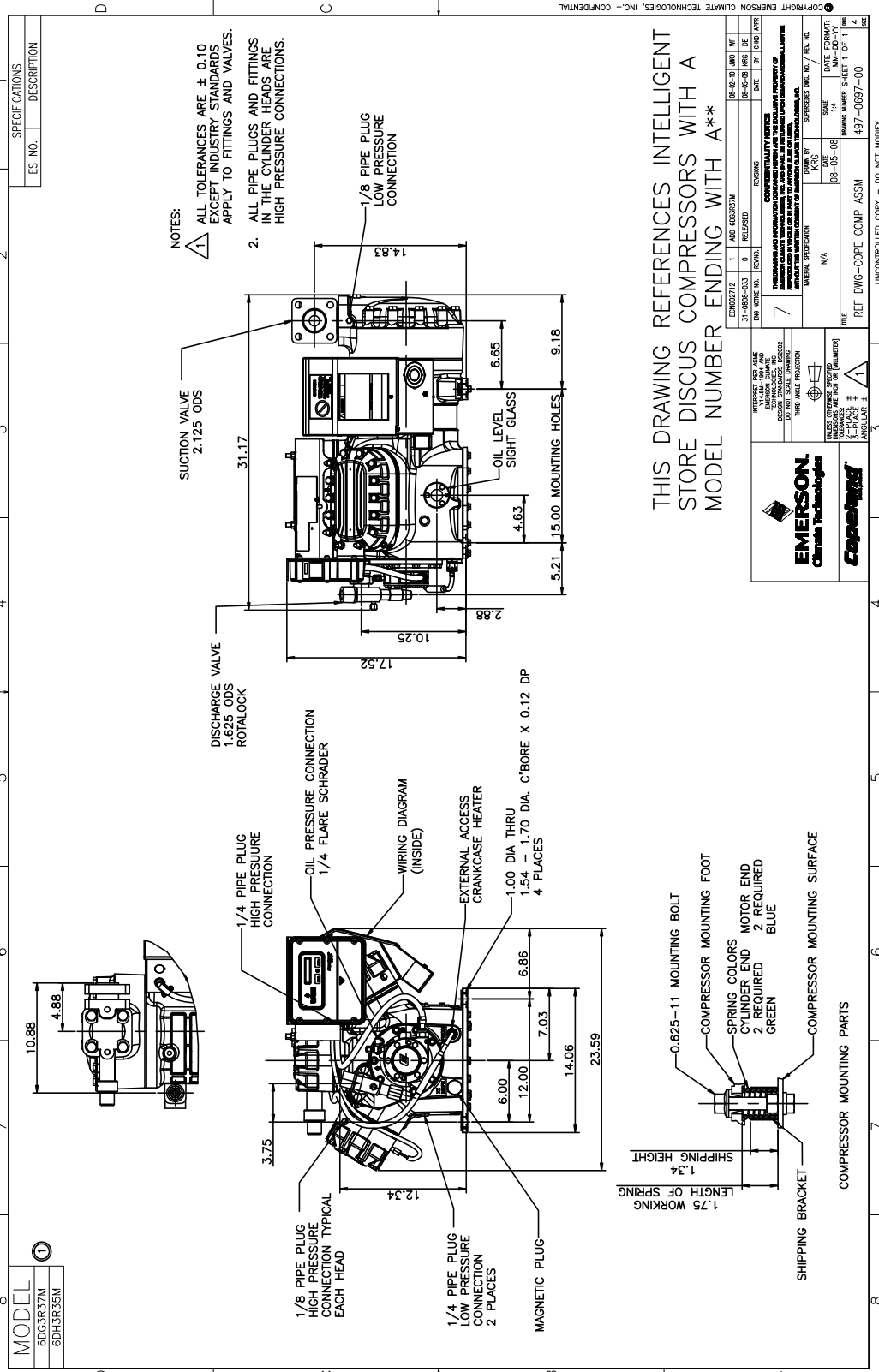

Appendix F

Technical Support

For technical support or assistance in resolving issues with the Copeland Discus compressor with CoreSense Diagnostics, contact the Emerson Retail Solutions support line. The contact number is (770)-425-2724.

Emerson Retail Solutions does not provide parts support. Contact your Emerson Climate Technologies Wholesaler for service parts.

Appendix G

CoreSense Diagnostics Service Parts List

Kit Part Number	Description	Model
980-0074-00	Module Upgrade Kit; Conversion of ISD v2.0 to CoreSense Diagnostics v2.11	All
917-0001-00	Nyogel Kit; Connector Lubricant for discharge temperature probe	All
943-0013-02	Control Module Kit	All
943-0062-02	Sensor Module Kit	All
929-0067-00	Electrical Assembly Harness Kit	4D/6D
943-0064-00	Current Sensor Kit	All
976-0003-00	Conduit-Wire Assembly Kit	2D/3D
918-0028-11	Crankcase Heater Kit (240V)	2D/3D
918-0028-17	Crankcase Heater Kit (240V)	4D/6D
923-0073-00	Unloader Coil Kit (Moduload and Blocked Suction)	3D/4D/6D
923-0084-00	Digital Unloader Coil Kit (24VAC)	3D/4D/6D
929-0071-00	Oil Pressure Harness Kit	All
985-0109-07	Temperature Probe Sensor Kit	All
985-0125-00	High Pressure Switch (Cut-out: 375 Cut-in: 265)	All
985-0125-04	High Pressure Switch (Cut-out: 550 Cut-in: 450) for R410A	All
985-0183-01	Low Pressure Switch (White Dot; Cut-out: 3 Cut-in: 12)	All
985-0125-02	Low Pressure Switch (White Dot; Cut-out: -2 Cut-in: 8) for R407A/R407C	All
998-0326-00	Moduload Valve Kit (without coil)	3D
998-0212-00	Unloader Valve Kit (without coil; NON-digital)	4D/6D
910-0111-00	Digital Unloader Valve Kit (without coil)	3D/4D/6D

Kit Part Number	Description	Model
910-0351-00	2D Demand Cooling Valve kit (valve only)	2D
910-0351-02	3D Demand Cooling Valve kit (valve only)	3D
910-0351-03	4D Demand Cooling Valve kit (valve only)	4D
910-0356-00	6D Demand Cooling Valve kit (valve only)	6D
910-0351-04	6D Demand Cooling Valve Assembly kit (valve, tube assembly and coil)	6D
910-0069-00	Demand Cooling Coil Kit (24VAC)	All

The contents of this publication are presented for informational purposes only and are not to be construed as warranties or guarantees, express or implied, regarding the products or services described herein or their use or applicability. Emerson Climate Technologies, Inc. and/or its affiliates (collectively "Emerson"), as applicable, reserve the right to modify the design or specifications of such products at any time without notice. Emerson does not assume responsibility for the selection, use or maintenance of any product. Responsibility for proper selection, use and maintenance of any Emerson product remains solely with the purchaser or end user.