



Head Pressure Control Valves

OROA-5, ORI-6-65/225H, ORI-10-65/225-H, ORD-4

INSTALLATION INSTRUCTIONS

To ensure proper performance, head pressure control valves must be selected and applied correctly. This is covered thoroughly in Bulletin 90-30. However, proper installation procedures are equally important.

VALVE LOCATION/PIPING SUGGESTIONS — The OROA, ORI and ORD valves can be installed in horizontal or vertical lines – whichever best suits the application, and permits easy accessibility of all valves. Consideration should be given to locating these valves so they do not act as an oil trap and so solder cannot run into the internal parts during brazing. Precautions should also be taken to install the valves with the flow in the proper direction.

The ORI valve CANNOT be installed in the discharge line for any reason.

Figures 1 and 2 are piping schematics only to illustrate the general location of the OROA, ORI, and ORD valves in the system. Sporlan recommends that recognized piping references be consulted for assistance in piping procedures. Sporlan is not responsible for system design, or for misapplication of its products. If these valves are applied in any manner other than described in this bulletin, the Sporlan warranty is void.

In most cases, the valves are located at the condensing unit. When the condenser is remote from the compressor, the usual location is near the compressor. In all cases, it is important that some precautions be taken in mounting the valves. It is suggested that they be adequately supported to prevent excessive stress on the connections. Discharge lines are a possible

source of vibrations and gas pulsations, which may result in fatigue in tubing, fittings, and connections. The severity of discharge gas pulses differs with each system. On some applications it may be necessary to dampen the pulses to protect the ORD-4 internal parts. **Pulsations are best handled by a good muffler placed as close to the compressor as possible.**

Vibrations from moving parts of the compressor are best isolated by flexible loops or coils (discharge lines 1/2" or smaller), or flexible metal hoses for larger lines.

For best results, the hoses should be installed as close to the compressor shut-off valves as possible, and mounted horizontal and parallel to the crankshaft or vertically upward. The hoses should **never** be mounted horizontal and 90° from the crankshaft. A rigid brace should be placed on the outlet end of the hose to prevent vibrations beyond the hose.

The inlet connections on the OROA-5, ORI-6 and ORI-10 valves should be sized the same as the outlet of the condenser where possible. The ORD-4 is available with 5/8" ODF and 7/8" ODF solder connections. On systems with discharge lines smaller than 5/8" OD, the bypass line can be the same size as the discharge line and the ORD-4 connections can be bushed down. If the system capacity is greater than any of the head pressure control valves ratings, these valves can be applied in parallel.

CAUTION: When the head pressure control valves are factory installed and capped for future hook-up in the field, any holding charge in the condensing unit and valve assembly should be bled off from **all** sides of the valves before removing the caps. This will prevent the caps from blowing off due to any trapped refrigerant.

Figure 1

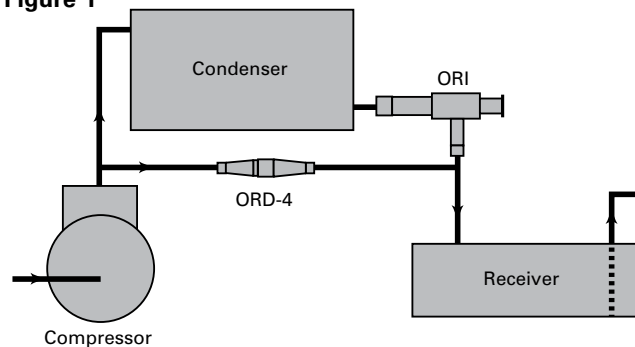
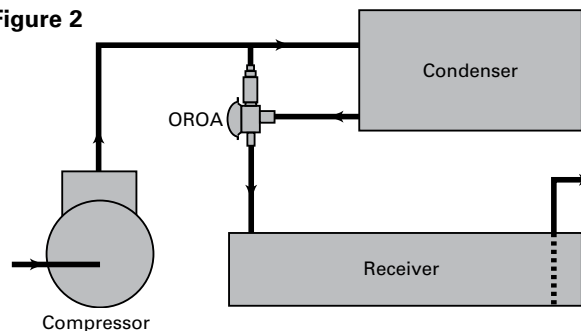

Figure 2



VALVE STRAINERS – Catch-All® filter-driers – See-All® moisture and liquid indicator — Just as with any refrigerant flow control device, the need for an inlet strainer is a function of system cleanliness and proper installation procedures. When the strainer is used with the ORI, the tubing is inserted in the valve connection until the tubing and strainer flange ring are up against the tubing stop, thus locking the strainer in place. See Figure 3. In order for the strainer to seat properly against the tubing stop of the OROA condenser connection, the strainer is inserted into the tubing. The tubing is then inserted into the valve connection, thus locking the strainer in place. See Figure 4.

Figure 3

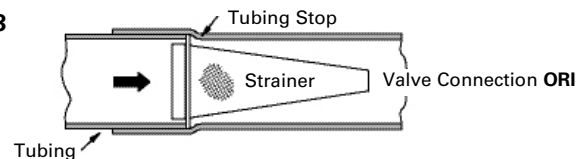
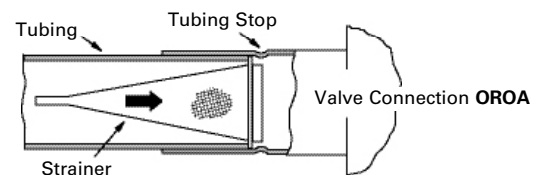

Figure 4



Moisture and particles too small for the inlet strainer are harmful to the system and must also be removed. Therefore, for complete system protection, it is recommended that a **Catch-All Filter-Drier** be installed in the liquid line according to the application recommendations given in Bulletin 40-10.

Moisture detection is easily and inexpensively provided with the installation of a **See-All moisture and liquid indicator**. Complete information is given in Bulletin 70-10. Furthermore, a **See-All moisture and liquid indicator** at the receiver is necessary to charge the system properly.

BRAZING PROCEDURES — Any of the commonly used brazing alloys for high side usage are satisfactory. However, when soldering or brazing, it is very important that the internal parts be protected by wrapping the valve with a WET cloth to keep the body temperature below 250°F for the OROA and ORI; and, 300°F for the ORD-4. Also, when using high temperature solders, the torch tip should be large enough to avoid prolonged heating of the copper connections. And, always direct the flame away from the valve body.

TEST and OPERATING PRESSURES — Excessive leak testing or operating pressures may damage these valves and reduce the life of the operating members. For leak detection, an inert dry gas, such as nitrogen or CO₂, may be added to an idle system to supplement the refrigerant pressure.

CAUTION: Inert gases must be added to the system carefully through a pressure regulator. Unregulated gas pressure can seriously damage the system and endanger human life. Never use oxygen or explosive gases.

The table below lists the maximum values each valve can withstand without damage. Precautions must be taken to keep test or operating pressures below these values.

Valve Type	Maximum Rated Pressure - psig
OROA	450
ORI-6-65/225-H	450
ORI-10-65/225-H	450
ORD-4	450

VALVE SETTINGS and ADJUSTMENT — A complete discussion on pressure settings is given in the Application Section of Bulletin 90-30. To determine the proper setting for a specific system, that section should be reviewed.

Table 1 lists the setting data for the OROA, ORI and ORD valves. Other ORI settings can be obtained by adjusting the valves a proportionate amount between those values shown.

Table 1

Valve Type	Standard Factory Setting for Refrigerants 12 & 134a		Setting For Refrigerants 22, 404A & 507		
	Pressure Setting psig	Depth of adjusting nut from top of Spring Housing	Pressure Setting psig	Depth of adjusting nut from top of Spring Housing	Turns IN from Refrigerant 12 Setting
OROA	100	-	180	-	-
ORI-6	120	1/4"	200	1/2"	3
ORI-10	120	3/8"	200	3/4"	5
ORD-4-20	20	-	20	-	-

The ORD-4-20 setting means that the ORD-4 will start to open when the pressure difference between the discharge line and the receiver is 20 psig. This setting is suitable for all systems where the combined pressure drop through the condenser, the ORI and connecting piping is **less than 14 psi**. Therefore, if the ORI is selected for 2 psi ΔP, then the maximum allowable pressure drop through the condenser is 12 psi. Normally, condenser pressure drop on refrigeration systems is less than 10 psi. However, many condensers on air-conditioning systems may have pressure drops up to 25 psi. Therefore, when in doubt, consult with the equipment manufacturer or, if possible, measure it by reading the discharge pressure at the compressor and the receiver pressure **during full load operation**. That is, this reading should be taken with a normal condensing temperature at full load. For systems where the condenser pressure drop is higher than normal, OROA and ORD valves with higher settings are available upon **special** request. See Table 4, page 4.

To adjust the ORI valve, remove the cap and turn the adjustment screw with the proper size hex wrench (1/4" for ORI-6 and 5/16" for ORI-10). A clockwise rotation increases the valve setting while a counter-clockwise rotation decreases the setting. To obtain the desired setting, a pressure gauge should be utilized at the compressor discharge service valve so the effects of any adjustment can be observed. Small adjustments are recommended to allow the system adequate time to settle out after each adjustment.

NOTE: Even though the ORI valve is selected on the basis of the full load conditions or summer operation, it should be adjusted to maintain the desired condensing pressure whenever the ambient is below 70°F.

REFRIGERANT CHARGE AND CHARGING PROCEDURES — When this method of head pressure control is utilized on a system, there must be enough refrigerant to flood the condenser at the lowest expected ambient and still have enough charge in the system for proper operation. A shortage of refrigerant will cause hot gas to enter the liquid line and the expansion valve, and refrigeration will cease.

Secondly, the receiver must have sufficient capacity to hold at least **all** of the excess liquid refrigerant in the system, since it will be returned to the receiver when high ambient conditions prevail. If the receiver is too small, liquid refrigerant will be held back in the condenser during the high ambient conditions and excessively high discharge pressures will be experienced.

CAUTION: All receivers must utilize a pressure relief device according to the applicable standards or codes (e.g. ARI Standard 495).

The charging instructions described on page 3 use average values. The exact charge required will vary with unit design and piping. These instructions are intended to provide assistance to the service technician where specific charging instructions for the condensing units involved are not available.

Charging Procedure:

1. Before starting the system, charge approximately 2-1/2 lbs. per ton of liquid refrigerant into the receiver **or** enough refrigerant to provide a liquid seal in the receiver.
2. Put refrigerant vapor into the suction side to break the vacuum.
3. Start the system and charge to a **clear See-All moisture and liquid indicator**.

CAUTION: Bubbles in the **See-All** don't necessarily indicate a shortage of charge, especially when it is located downstream of other liquid line components and/or remotely from the receiver. When satisfied with a clear **See-All** (or that any bubbles are caused by reasons other than a shortage of charge), the system is correctly charged for the charging ambient.

- The extra **winter** charge (as calculated below) is now weighed into the receiver.

To determine the extra charge required, calculate the total length of tubing in the condenser including the equivalent length for return bends. See Table 2. Then multiply the total length in feet by the number of pounds per foot for the proper refrigerant and condenser tube size from Table 2.

Table 2

Tubing Size and Thickness Inches		Equivalent Length for Each Return Bend-Feet	Refrigerant per Foot of Tubing Pounds @ -20°F		
			Refrigerant		
			12	22	502
3/8	.016	.20	.060	.055	.057
1/2	.017	.25	.110	.102	.106
5/8	.018	.30	.175	.163	.169

Example: R-12 system with 1170 equivalent feet of 1/2 inch tubing in the condenser.

$1170 \times .110 = 130 \text{ pounds}$

The amount of refrigerant calculated using Table 2 must be corrected since the condenser might be already partially flooded especially if charging is being done at low ambients. Table 3 provides information on percentage of condenser to be flooded at various ambients for high, medium and low suction condensing units. To determine the **extra charge**, determine the difference in percentage between the charging ambient and the minimum winter ambient and multiply the figure by the pounds of refrigerant calculated before.

Example: High Suction Condensing Unit, 40°F evaporating temperature

-20°F Minimum Winter Ambient	.79
50°F Charging Ambient	-<u>.40</u>
	.39

$130 \times .39 = 51 \text{ lbs. of extra charge}$

These calculations do not take into account cylinder unloading. Additional charge will be required. For more complete charging recommendations, see Sporlan Bulletin 90-30-1.

Condenser Ambient Temperature °F	Percentage of Condenser to be Flooded											
	Low Suction Condensing Units				Medium Suction Condensing Units				High Suction Condensing Units			
	Evaporating Temperature - °F											
	-35	-25	-15	-5	0	10	20	30	35	40	45	50
80	27	15	0	0	0	0	0	0	0	0	0	0
70	62	49	35	15	40	24	0	0	0	0	0	0
60	76	65	56	45	60	47	33	17	26	20	10	4
50	83	75	68	60	70	60	50	38	45	40	33	28
40	86	80	74	68	76	68	60	50	56	52	46	42
30	88	84	79	74	80	73	66	59	64	60	55	51
20	90	86	82	78	83	77	72	65	69	66	62	59
0	92	89	86	82	87	83	78	73	76	73	70	68
-20	94	91	88	86	91	87	82	77	80	79	76	73
-40	97	94	92	90	94	89	84	79	83	81	79	77

SERVICE INSTRUCTIONS

There are several possible causes for system malfunction with "refrigerant side" head pressure control and these may be difficult to isolate from each other. As with any form of system trouble-shooting, it is necessary to know the existing operating temperatures and pressures before system problems can be determined. Once the actual malfunction is estab-

lished, it is easier to pinpoint the cause and then take suitable corrective action. The following chart lists the most common malfunctions, the possible causes, and the remedies. Since the OROA, ORI and ORD are hermetic valves and cannot be disassembled for inspection and/or replacement of parts, they must be replaced if they become inoperative.

Malfunction - Low Head Pressure	
Possible Cause	Remedy
1. Insufficient Refrigerant charge to adequately flood condenser.	Add charge.
2. Low pressure setting on ORI.	Increase setting.
3. ORI fails to close due to foreign material in valve.	Turn Adjustment out so material passes through valve. If unsuccessful, replace ORI.
4. ORI fails to adjust properly.	See 3 above.

Malfunction - Low Head Pressure (Continued)	
Possible Cause	Remedy
5. Wrong setting on OROA (e.g. 100 psig on Refrigerant 22 or 404A system).	Replace OROA with valve at correct setting.
6. OROA fails to close due to: a. Foreign material in valve. b. Loss of air charge in element.	See below: a. Cause OROA to open by raising condensing/receiver pressure above valve setting by cycling condenser fan. If foreign material does not pass through valve, replace OROA. b. Replace OROA.
7. ORD fails to open due to: a. Less than 20 psi pressure drop across ORD. b. Internal parts damaged by overheating when installed.	See below: a. Check ORI causes/remedies on page: 2, 3, or 4. b. Replace ORD

Malfunction - High Head Pressure	
Possible Cause	Remedy
1. Dirty condenser coil.	Clean coil.
2. Air on condenser blocked off.	Clear area around unit.
3. Too much refrigerant charge.	Remove charge until proper head pressure is maintained.
4. Undersized receiver.	Check receiver capacity against refrigerant required to maintain desired head pressure.
5. Non-condensibles (air) in system.	Purge from system.
6. High pressure setting on ORI.	Decrease setting.
7. ORI or OROA restricted due to inlet strainer being plugged.	Open inlet connection to clean strainer.
8. ORI fails to adjust properly or to open due to foreign material in valve.	Turn adjustment out so material passes through valve. If unsuccessful, replace ORI.
9. Wrong setting on OROA (e.g., 180 psig on Refrigerant 12 system).	Replace OROA with valve at correct setting.
10. Bypassing hot gas when not required due to: a. If ORI, ORD are used and internal parts of ORD are damaged by overheating when installed. b. If OROA is used and internal parts are damaged by overheating when installed. c. If ORI uses a pressure drop across condenser, associated piping and ORI exceeds 14 psi under full load conditions. d. If OROA used and pressure drop across condenser, associated piping and OROA exceeds 14 psi under full load condition.	See below: a. Replace ORD. b. Replace OROA. c. Reduce pressure drop in piping by using larger ORI or ORI larger valves in parallel or use ORD with higher setting. d. Reduce pressure drop by using 2 - OROA in parallel or substitute OROA with higher ORD setting. See table below.

INSTALLATION PRECAUTIONS

1. See page 2 for safe working pressures.
2. Do not overcharge — see charge and charging procedures on pages 2 and 3.
3. Be sure that the piping does not allow liquid refrigerant to be trapped in sections where hydrostatic pressure can develop.
4. Be sure that the receiver is large enough to hold the entire charge during “warm” operation.
5. Do not overheat — see brazing procedures on page 2.
6. “Caution:” on page 1, right column.
7. “Caution:” on page 2, left and right column.
8. “Caution:” on page 3, left column.

Table 4

Maximum Pressure Drop Between Compressor and Receiver - psi	Head Pressure Component Selection
Below 14	OROA-5-100 or -180 ORD-4- 20 & ORI
15 - 19	*OROAB-5-100 or -180 *ORD-4- 25 & ORI
20 - 24	*OROAC-5-100 or -180 *ORD-4- 30 & ORI
25 - 29	*OROAD-5-100 or -180 *ORD-4- 35 & ORI

Bold type indicates pressure range.
*Available on special order ONLY.

WARNING: Serious injury could result from an explosion caused by the rapid expansion of trapped liquid refrigerant subjected to high temperature. ALWAYS OPEN OR VENT THE SYSTEM BEFORE APPLYING HEAT TO REMOVE SYSTEM COMPONENTS. Break the element charging cap tube on valve dome by hand or with a clean cut tool. DO NOT use side cutters, which may seal the opening.

