



Código : 915144 Motoc"DISCUS"-3DS3A100E-TFD200--B404----

3DB3A100E-TFD

HFC, R-404A ,Mid Point, 50 Hz, 3 - Phase, 380/420 V

Medium Temperature

Estado de Producción: This model is obsolete and is no longer in production for both OEM and service replacement.

Rendimiento

Evap(°C)/Cond (°C)	-6.7/48.9	-17.8/43.3
RG(°C)/Liq(°C)	18.3/48.9	18.3/43.3
Capacidad (Watts):	21100	14800
Potencia (Watts):	9250	7300
Corriente (Amps):	16.6	13.8
EER (COP):	2.29	2.02
Flujo de Masa(g/s):	192	121
Potencia del Sonido (dBA):	0 Ave 0 Max	
Vibración(mm(peak-peak)):	0 Ave 0 Max	

Mecánico

Número de Cilindros:	3	CIR (meters ³ /hr):	0.753
Medida de Calibre (mm):	60.3	CFH (meters ³ /hr):	37.895
Recorrida (mm):	50.8		
Lago Total (mm):	680.21	Largo (mm):	381
Ancho Total (mm):	382.52	Ancho (mm):	304.8
Altura Total (mm):	457.96	Altura (mm):	484.12*
Medida de Succión(in):	1 3/8	Sweat	
Medida de Descarga (in):	1 1/8	Sweat	
Carga Inicial de Aceite (liter):	3.7		
Recarga de Aceite (liter):	3.4		
Peso Neto (kg):	174.63		
HorsePower	7.5		
* Altura total del compresor sobre patas de montaje Copeland originales.			

Eléctrico

LRA-Alto*:	106.0	UL File No.:	SA-2337	Corriente Operativa Máx.(Amps):	
LRA-Bajo*:		UL File Date:	26-Jul-1985	MCC (Amps):	28.0
LRA-Medio Bobinado:		Archivo CSA No.:	LR3104C	RPM:	
RLA (=MCC/1.4; use for contactor selection):	20				
RLA (=MCC/1.56; use for breaker & wire size selection):	17.9				
*Baja y Alta, se refieren respectivamente, a los límites inferior y superior del rango de voltaje de trabajo para el cual el motor está aproba					

Aplicaciones Alternativas

Refrigerante	Frecuencia(Hz)	Fase	Voltaje	Aplicación
R-22 HCFC	60	3	460	
R-22 HCFC	60	3	460	
R-22 HCFC	60	3	460	Air Conditioning
R-22 HCFC	60	3	460	Medium Temperature
R-404A HFC	60	3	460	Medium Temperature
R-502 CFC	60	3	460	
R-507 HFC	60	3	460	Medium Temperature
R-22 HCFC	50	3	380/420	
R-22 HCFC	50	3	380/420	
R-22 HCFC	50	3	380/420	Air Conditioning
R-22 HCFC	50	3	380/420	Medium Temperature
R-502 CFC	50	3	380/420	
R-507 HFC	50	3	380/420	Medium Temperature

3DS3A100E-TFD



HFC, R-404A, Mid Point, 50 Hz, 3 - Fase, 380/420 V

Low Temperature

Estado de Producción: This model is obsolete and is no longer in production for both OEM and service replacement.

Componentes Eléctricos

Estatos

Resistencia: +-7%

Tensión entre fases: 1.178

Tensión de línea: 0.0

Protector térmico interno

N° de Parte 071-0429-09

Descripción de Uso:

Nombre del Vendedor:

T I



Condiciones operativas

18.3 C Return Gas
 0 K Subcooling
 35 C Ambient Air Over

50 Operación en Hz**LOW****TEMPERATURE**

HFCs Require Use of Polyol Ester
 Lubricant Approved by Bulletin
 AE-1248

3DS3A100E-TFD

COPELAMETIC® HFC-404A

DISCUS® COMPRESSOR

TFD 380/420-3-50

Condensing Temperature C**(Sat Dew Pt Pressure, bar)****Evaporating Temperature C (Sat Dew Pt Pressure, bar)**

	54	-40 (1.3)	-35 (1.7)	-30 (2)	-25 (2.5)	-20 (3)	-18 (3.3)
(25.2) C	5200	6950	9050	11550	14550	15900	
P	5500	6600	7700	8900	10100	10600	
A	11.2	12.7	14.3	16	17.9	18.7	
M	48.7	65.5	85.5	110.5	140	153	
E	0.94	1.05	1.17	1.3	1.44	1.49	
%	69.4	70.7	71.6	72	71.9	71.6	
50 C	5800	7750	10000	12750	16000	17400	
(23) P	5550	6600	7650	8750	9950	10400	
A	11.2	12.7	14.2	15.9	17.7	18.4	
M	50.8	68	88.5	113.5	143	157	
E	1.05	1.18	1.31	1.45	1.61	1.67	
%	69.9	71	71.7	72	71.6	71.3	
45 C	6450	8600	11100	14100	17600	19200	
(20.5) P	5500	6500	7500	8550	9650	10100	
A	11.2	12.5	14	15.5	17.2	17.8	
M	52.5	70	91	116	146	160	
E	1.18	1.32	1.48	1.65	1.83	1.9	
%	69.8	70.8	71.5	71.7	71.2	70.8	
40 C	7050	9400	12150	15400	19200	20900	
(18.2) P	5400	6350	7350	8300	9250	9650	
A	11	12.3	13.7	15.1	16.6	17.2	
M	53.7	71.5	93	118.5	149	163	
E	1.31	1.48	1.66	1.86	2.07	2.16	
%	69.2	70.4	71	71.2	70.7	70.2	
35 C	7650	10200	13200	16700	20800	22600	
(16.1) P	5300	6200	7100	7950	8850	9200	
A	10.8	12.1	13.3	14.6	15.9	16.4	
M	54.9	73.5	95.5	121	152	165	
E	1.45	1.65	1.86	2.09	2.35	2.46	
%	68.7	70	70.7	70.8	70.1	69.6	
30 C	8400	11150	14400	18100	22500	24400	
(14.2) P	5150	6050	6850	7650	8400	8700	
A	10.7	11.9	13	14.1	15.3	15.7	
M	56.8	76	98	124.5	155	169	
E	1.62	1.85	2.1	2.37	2.68	2.8	
%	68.8	70	70.6	70.5	69.7	69.1	
25 C	9300	12300	15800	19800	24400	26500	
(12.5) P	5050	5900	6650	7300	7950	8200	
A	10.7	11.8	12.8	13.8	14.8	15.1	
M	59.9	79.5	102.5	129	160	174	
E	1.84	2.09	2.38	2.7	3.07	3.22	
%	69.6	70.5	70.8	70.5	69.3	68.6	



anSal
 REFRIGERACION S.A.
 Desde 1946

3DS3A100E-TFD

HFC, R-404A, Mid Point, 50 Hz, 3 - Fase, 380/420 V

Low Temperature



Estado de Producción: This model is obsolete and is no longer in production for both OEM and service replacement.

Partes de Servicio

<u>Referencia</u>	<u>Componente</u>	<u>Cantidad</u>	<u>Descripción</u>	<u>Comentarios</u>
1	020-0730-00	1	GASKET-CYLINDER HEAD	
3	998-2661-43	1	VALVE PLATE KIT	
4	020-0749-00	1	GASKET-HOUSING COVER	
5	020-0732-00	1	GASKET-OIL PUMP	2942708
6	998-0008-33	1	OIL PUMP KIT	WITH VALVESBOLTSGASKETS& ADAPTER RING
7	020-0681-02	1	GASKET-BOTTOM PLATE	2951502
8	998-0002-02	1	SIGHT GLASS KIT	
9	020-0709-00	1	GASKET-STATOR COVER	
10	005-0650-03	1	COVER-STATOR	
13	020-0012-09	1	GASKET-SERVICE VALVE	2880908 SUCTION
14	998-0510-11	1	SERV VALVE KIT 1 3/8 SWT	2 BOLTSUCTION
15	020-0146-00	1	GASKET-TERM MTG PLATE	
17	062-0205-00	1	BOX-TERMINAL	
19	503-0804-00	1	PLATE-TERMINAL GROUP	
20	505-0281-08	1	COVER-TERMINAL ASSM	
21	998-0429-09	1	PROTECTOR & GASKET KIT	
24	510-0191-00	1	VALVE-SCHRADER TEE	INSTALLED IN OIL PUMP
25	020-0844-04	1	SEAL-SIGHT GLASS	2042028
26	998-0510-02	1	SERV VALVE KIT 1 1/8 SWT	ROOTALOCKDISCHARGE
27	998-5100-02	1	SUCT & DISCH VALVE KIT	WITH VALVESBOLTS& GASKETS
29	998-0513-03	1	OIL SCREEN KIT	
30	918-0028-00	1	HEATER-CC--100W/120V	WELD
30	918-0028-01	1	HEATER-CC--100W/240V	WELD
31	003-0770-00	1	PLATE-BOTTOM	2728153
32	998-0700-02	1	BRACKET KIT	
33	510-0142-00	1	VALVE-OIL CHECK ASSM	2852661
35	020-0028-03	1	SEAL-VALVE	TEFLON 1.500 O.D. DISCHARGE
36	020-0678-00	1	GASKET-CLOSURE PLATE	
40	998-1669-04	1	GASKET SET	
41	527-0045-00	1	SPACER-MOUNTING ASSM	
44	080-0026-00	1	BLOCK-TERMINAL	
46	998-0036-00	1	ROOTALOCK ADAPTER KIT	ADAPTER USED TO MOUNT A ROOTALOCK DISCHARGE SERVICE VALVE
52	030-0187-00	1	SLEEVE-HEATER	
61	020-0297-13	1	GASKET-SENTRONIC SENSOR	
62	998-0513-04	1	SUCTION SCREEN KIT	

<u>Referencia</u>	<u>Componente</u>	<u>Cantidad</u>	<u>Descripción</u>	<u>Comentarios</u>
64	020-0012-09	2	GASKET-SERVICE VALVE	2880908 GASKET REQUIRED ON BOTH SIDES OF MUFFL PLATE
65	003-0107-00	1	PLATE-RESTRICTOR	2474138
69	910-0352-08	1	DEMAND COOL VLV & COIL	COIL VOLTAGE 240V/50HZ
69	910-0352-02	1	DEMAND COOL VLV & COIL	COIL VOLTAGE 120V/60HZ
69	910-0352-03	1	DEMAND COOL VLV & COIL	COIL VOLTAGE 240V/60HZ
69	910-0352-10	1	DEMAND COOL VLV & COIL	COIL VOLTAGE 120V/50HZ
70	998-1000-13	1	DEMAND COOL KIT	120V 60 HZ
70	998-1001-13	1	DEMAND COOL 120V/50 HZ	
71	998-1000-23	1	DEMAND COOLING KIT	240V 60 HZ
71	998-1001-23	1	DEMAND COOL 240V/ 50 HZ	
72	920-0981-03	1	V-PLATE GASKET KIT	DELTA REED

3DS3A100E-TFD

HFC, R-404A, Mid Point, 50 Hz, 3 - Fase, 380/420 V

Low Temperature

Estado de Producción: This model is obsolete and is no longer in production for both OEM and service replacement.



Accesorios

<u>Número de Pa</u>	<u>Descripción</u>
023-0039-01	Coil, 120v, Alco - Demand cooling valve (Unloader Valve)
023-0039-02	Coil, 240v, Alco - Demand cooling valve (Unloader Valve)
023-0042-01	Solenoid Coil 120v, 50/60 Hz, Parker - Demand cooling valve
023-0042-02	Solenoid Coil 240v, 50/60 Hz, Parker - Demand cooling valve
024-0200-00	Fan Guard - Top, for Head Cooling Fan
030-0187-00	Heater Sleeve, well style - Order well separately
083-0118-00	Fan Blade - for Head Cooling Fan
085-0109-00	Temperature Probe-Standard 41" - Demand Cooling
085-0109-01	Temperature Probe-10 ft cable - Demand Cooling
085-0110-00	Control Module 120v 50/60 Hz - Demand Cooling
085-0110-01	Control Module 240v 50/60 Hz - Demand Cooling
085-0160-00	3 Phase Voltage Monitor. For use with all Copeland 3 Phase Compressors. Consult model family nomenclature for electrical definition in the model number.
510-0351-01	Demand Cooling Valve 60 Hz Alco
510-0351-02	Demand Cooling Valve 50 Hz Alco
510-0352-02	Demand Cooling Valve & Coil 120v, 60 Hz, Alco
510-0352-03	Demand Cooling Valve & Coil 240v, 60 Hz, Alco
510-0352-08	Demand Cooling Valve & Coil 240v, 50 Hz, Alco
510-0352-10	Demand Cooling Valve & Coil 120v, 50 Hz, Alco
585-1066-02	Sentronic Oil Pressure Control - Kit includes Sentronic oil pressure control, screws to mount control, oil pressure sensor, and sensor gaskets. Control mounting brackets are supplied on service replacement compressors.
918-0009-00	Crankcase Heater, 120v, 65w, bolt on. For usage on specific Copeland Copelametic & Discus Compressor except deep sump models. Includes crankcase heater, and reference drawings.
918-0009-01	Crankcase Heater, 240v, 65w, bolt on. For usage on specific Copeland Copelametic, & Discus Compressor except deep sump models. Includes crankcase heater, and reference drawings.
918-0009-02	Crankcase Heater, 480v, 65w, bolt on. For usage on specific Copeland Copelametic, & Discus Compressor except deep sump models. Includes crankcase heater, and reference drawings.
918-0009-03	Crankcase Heater, 600v, 65w, bolt on. For usage on specific Copeland Copelametic, & Discus Compressor except deep sump models. Includes crankcase heater, and reference drawings.
918-0009-04	Crankcase Heater, 12v, 65w, bolt on. For usage on specific Copeland Copelametic & Discus Compressors except deep sump models. Includes crankcase heater, and reference drawing.
998-0017-45	Kit-VP Replaces 998-0017-15 - Used on 3DK3-1200 & 120E, 3DT3-1500 & 150E, 3DT3-1000-Converts 3DF3-075x to 3DK3-075x, 3DS3-075x to 3DT3-075x, 3DF3-090x to 3DK3-090x, 3DS3-100x to 3DT3-100x, 3DF3-120x, & 3DS3-150x to 3DT3-150x
998-0017-46	Kit-Valve Plate Replaces 998-0017-16 - Used on 3DH3-0900 & 090E, 3DR3-1000 & 100E - Laser Reed Models converts 3DF3-090x to 3DG3-090x, & 3DJ3-100x to 3DR3-100x
998-0017-47	Kit-Valve Plate Replaces 998-0017-17 - Used on 3DH3-0600 & 060E, 3DJ3-0750 & 075E - LASER REED converts 3DA3-060x to 3DH3-060x, & 3DB3-075x to 3DJ3-075x
998-0017-48	Kit-Valve Plate Replaces 998-0017-18 - Used on 3DP3-1000 & 100E - LASER REED MODELS converts from 3DB3-075x to 3DP3-075x, & 3DB3-100x to 3DP3-100x
998-0017-49	Kit-Valve Plate Replaces 998-0017-19 - Used on 3DE3-0750 & 075E - LASER REED MODELS converts from 3DA3-075x to 3DEe-075x
998-0017-50	Kit-Valve Plate Replaces 998-0017-20 - Used on 3DE3-0500 - LASER REED converts 3DA3-050x to 3DE3-050x
998-0161-01	Sentronic Oil Control - Control only, supplied with 44" cable as standard
998-0162-00	Kit includes sensor, gaskets, and cable.
998-0283-02	Standard Sentronic cable is 44" long. The extension cable is 12 ft long and must be wired into the control. Kit 998-0283-02 includes instructions.

3DS3A100E-TFD

HFC, R-404A, Mid Point, 50 Hz, 3 - Fase, 380/420 V

Low Temperature

Estado de Producción: This model is obsolete and is no longer in production for both OEM and service replacement.



Accesorios

<u>Número de Pa</u>	<u>Descripción</u>
998-0326-02	Unloader Valve & Coil 120v
998-0326-03	Unloader Valve & Coil 240v
998-0550-00	Fan Motor Blade & Guard Assembly 230v, Does not include mounting bracket. Must be ordered separately
998-0550-01	Fan Motor Blade & Guard Assembly 460v, Does not include mounting bracket. Must be ordered separately
998-0550-02	Fan Motor Blade & Guard Assembly 115v, Does not include mounting bracket. Must be ordered separately
998-0550-03	Fan Motor 230v. Includes fan motor mounted to bottom guard
998-0550-04	Fan Motor 460v. Includes fan motor mounted to bottom guard
998-0550-05	Fan Motor 115v. Includes fan motor mounted to bottom guard
998-0574-08	Fan Mounting Kit. Vertical fan mount on top of compressor head 9D & 9R(2-5/8 head height - 9R**-XXX5 models & 3DA, 3DB, 3DF, 3DS)
998-0574-10	Fan Mounting Kit. Vertical fan mount on top of compressor head 3D moduload models (3DE, 3DG, 3DH, 3DJ, 3DK, 3DP, 3DR, 3DT)
998-0683-01	Shipping Plate, Gasket, and Bolt (Suction all 2) (Discharge all 3D, 4D, 4R, 6D, 6R & 9R) (Suction) (Suction 5, 6, 7 1/2, 9, & 10 12 HP)
998-0683-02	Shipping Plate, Gasket, and Bolt (Suction 6R, 10, 15 & 20 HP)
998-0700-09	Control Mounting Bracket Kit
998-1000-13	Demand Cooling Kit 120v / 60Hz
998-1000-23	Demand Cooling Kit 240v / 60Hz
998-1001-13	Demand Cooling Kit 120v / 50Hz
998-1001-23	Demand Cooling Kit 240v / 50Hz
998-2017-40	Converts 3DFxA120E to 3DKHA120E, & 3DSxA150E to 3DTHA150E
998-2017-41	Converts 3DF3A090E to 3DGHA090E, & 3DS3A100E to 3DRHA100E
998-2017-42	Converts 3DAxA060E to 3DHHA060E, & 3DBxA075E to 3DJHA075E
998-2017-43	Converts 3DB3A100E to 3DPHA100E
998-2017-44	Converts 3DAxA075E to 3DEHA075E
998-2017-45	Converts 3DF3A0750 to 3DK3A0750 and 3DF3A0900 to 3DK3A0900 and 3DF3A1200 to 3DK3A1200 and 3DS3A1000 to 3DT3A1000 and 3DS3A1500 to 3DT3A1500
998-2017-46	Converts 3DF3A0900 to 3DG3A0900 and 3DS3A1000 to 3DR3A1000
998-2017-47	Converts 3DA3A0600 to 3DH3A0600 and 3DB3A0750 to 3DJ3A0750
998-2017-48	Converts 3DB3A1000 to 3DP3A1000
998-2017-49	Converts 3DA3A0750 to 3DE3A0750 and 3DS3A07500 to 3DT3A07500
998-2017-50	Converts 3D3A0500 to 3DE3a0500
998-AB52-01	Akybenzene Oil. Approved for use with specific Copeland Semi Hermetic After Market Compressors. Consult model family nomenclatures for oil identifier in the model number.
998-E022-01	Polyol Ester Oil. Approved for use with specific Copeland Hermetic & Semi Hermetic models. Consult specific model family nomenclatures for oil identifier in the model number.

Boletín Cambio Nomenclatura Discus Cono Sur 

Actualización de Nomenclatura Discus Cono Sur 



MODEL	OLD MODEL NUMBER
3DA3R10M	3DA3A075
3DB3R12M	3DB3A100
3DF3F26K	3DF3A075
3DF3F40K	3DF3A090
3DF3R15M	3DF3A120
3DS3F30K	3DS3A075
3DS3F46K	3DS3A100
3DB3F34KE	

(23)

SPECIFICATIONS	
ES NO.	DESCRIPTION
ES81-159	CLEANLINESS
ES81-250	IDENTIFICATION
ES92-155	CONVERSION-METRIC
ES92-167	HAZARDOUS SUBSTANCES

NOTES:
 ⚠ ALL TOLERANCES ARE ± 3/32 EXCEPT INDUSTRY STANDARDS APPLY TO FITTINGS AND VALVES.

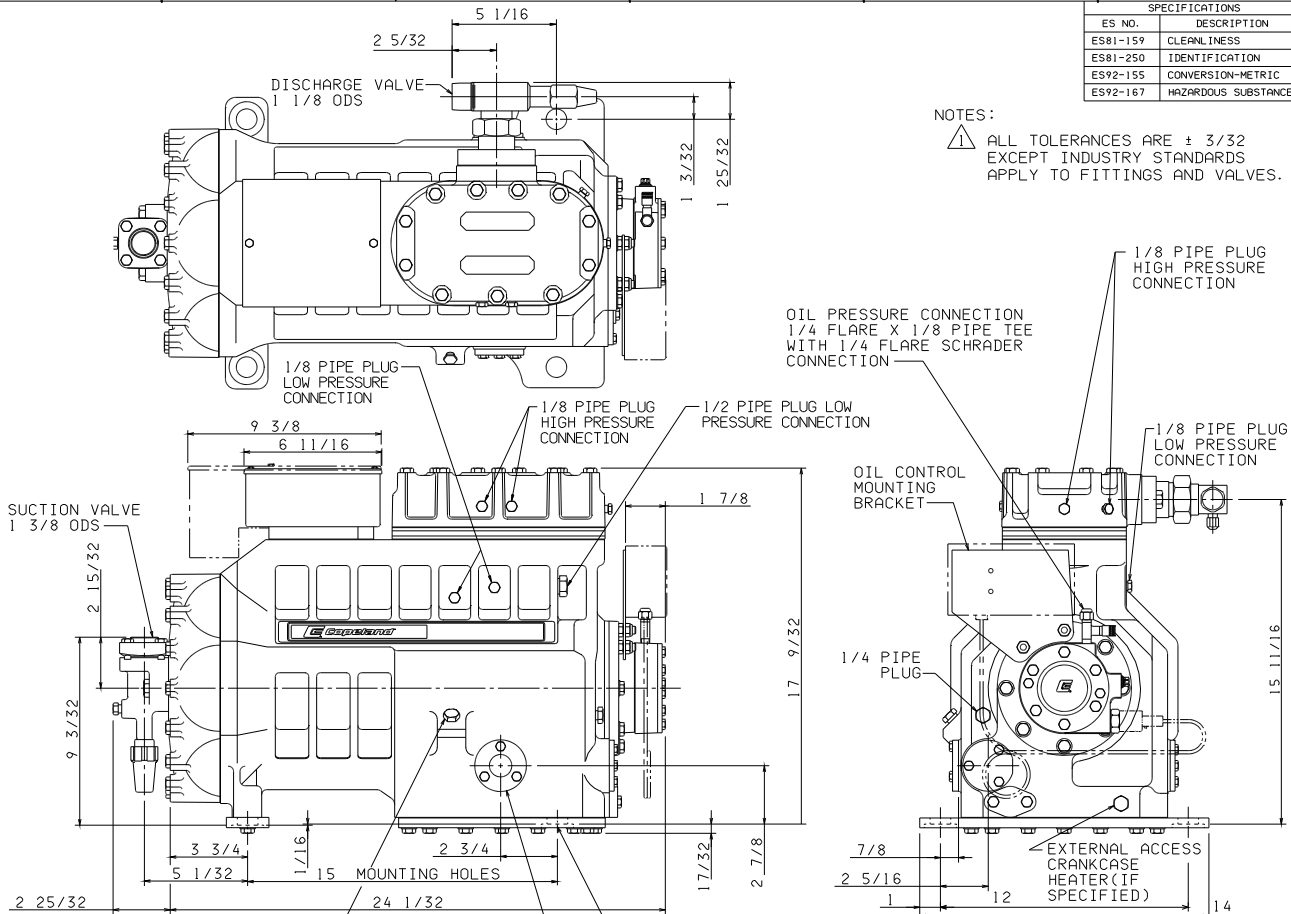
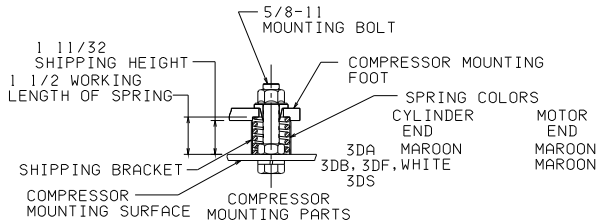
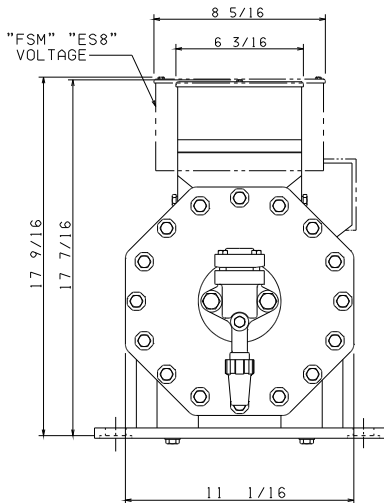

INTERPRET PER ASME Y14.5M-1994 AND COPELAND DESIGN STANDARDS DS2002. DO NOT SCALE DRAWING.

THIRD ANGLE PROJECTION

UNLESS OTHERWISE SPECIFIED DIMENSIONS ARE INCH (MILLIMETER). TOLERANCES:

2 PLACE: .015

3 PLACE: .005

ANGULAR: .1

ENG NOTICE NO.	REV NO.	REVISIONS	DATE	BY	CHKD	APPR
51-1105-037	23	ADDED MODEL 3DB3F34K	02-21-06	NVS	DE	
51-0805-121	22	REDRAWN: CHART UPDATED	09-28-05	NVS	DE	
51-1085-013		RELEASE	12-20-85	RN		

CONFIDENTIALITY NOTE	
7	THIS DRAWING AND THE INFORMATION CONTAINED HEREIN ARE THE EXCLUSIVE PROPERTY OF COPELAND. IT SHALL BE RETURNED TO COPELAND UPON DEMAND AND SHALL NOT BE REPRODUCED IN WHOLE OR IN PART, DISCLOSED TO ANYONE ELSE OR USED WITHOUT THE WRITTEN CONSENT OF COPELAND.

WATERMARK SPECIFICATION	DATE	SCALE	DATE FORMED
N/A	09-28-05	1:2	MM-DD-YY

TITLE	DRAWING NUMBER	SHEET 1 OF 1
REF DWG COPE COMP ASSY	497-0150-00	14

UNCONTROLLED - DO NOT MODIFY

COPELAND CORP. - CONFIDENTIAL