

McDaniel Metals

281-987-8400 • 281-987-9494 (fax)
1318 Buschong, Houston, TX 77039
www.mcdanielmetals.com

14CURB180240

14" KNOCKED DOWN ROOF CURB
FITS DAIKIN DCG180-240 AND
DCC180-240

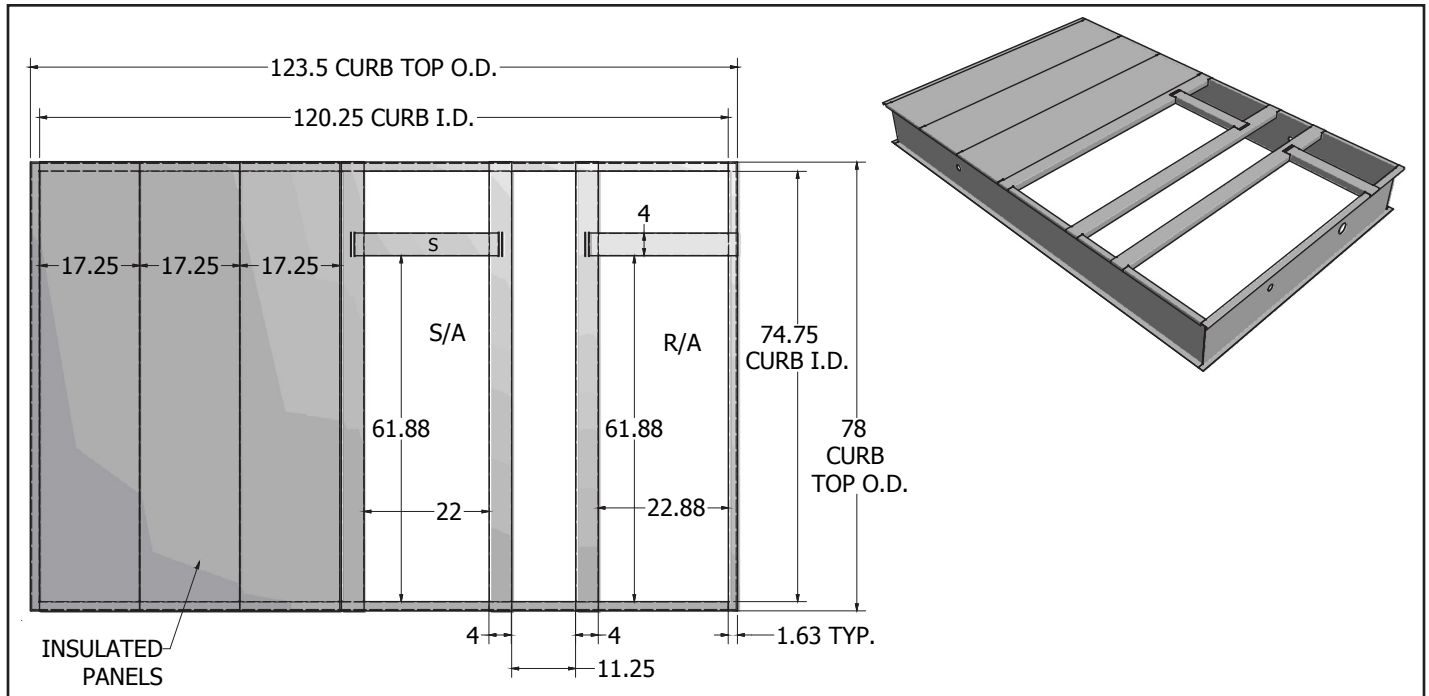

GENERAL

Roof curbs are shipped unassembled. Field assembly, squaring, leveling and mounting on the roof structure are the responsibility of the installing contractor. All curb installations must comply with local codes and should be done in accordance with the established guidelines of the National Roofing Contractors Association.

1. All required hardware necessary for the assembly of the sheet metal curb is included with the curb accessory.
2. Full perimeter type curb accessories are available. Full perimeter curbs include duct connection frames to be attached to the curb. Cantilever type curbs are not available from the factory.
3. Curbs must be supported on at least two parallel sides by roof members. Ensure that roof members do not penetrate supply and return duct opening areas.
4. Curb insulation, cant strip, flashings and general roofing material are to be furnished by the roofing contractor. Wood nailer strip and curb gasket is to be furnished with the curb accessory.
5. The unit and curb accessories are designed to allow vertical duct installation before unit placement. Duct installation after unit placement is not recommended.

TABLE 1	A	B	C
Full Perimeter Curb	123	78	145 5/8

1. Check package contents to ensure all the pieces are present.
2. Position perimeter pieces as depicted in Figure 1 and Figure 3 with wood to the outside, keeping the raw ends with the brackets holes facing one another.
3. Insert hooked tabs into slots and press down firmly.
4. Sandwich the sides of the curb between two brackets and use the nuts and bolts provided to complete the longer sides of the curb.
5. Install duct support pieces per Figure 1 and Figure 2.
6. Install insulated panels, metal side up, across the top of the condenser section of the curb.
7. Level and square the curb. Both diagonal measurements should be equal within a tolerance of 1/8" of C on Table 1. To level the curb, stretch two diagonal lines equipped with line levels. There must not be more than 1/8" spacing between the two lines at the point of intersection. Shim the curb until it is level. When the lines touch at the intersection, move the bottom line to the top and recheck.

!CAUTION!

ALL CURBS LOOK SIMILAR. TO AVOID INCORRECT CURB POSITIONING, CHECK JOB PLANS CAREFULLY AND VERIFY MARKINGS ON CURB ASSEMBLY.

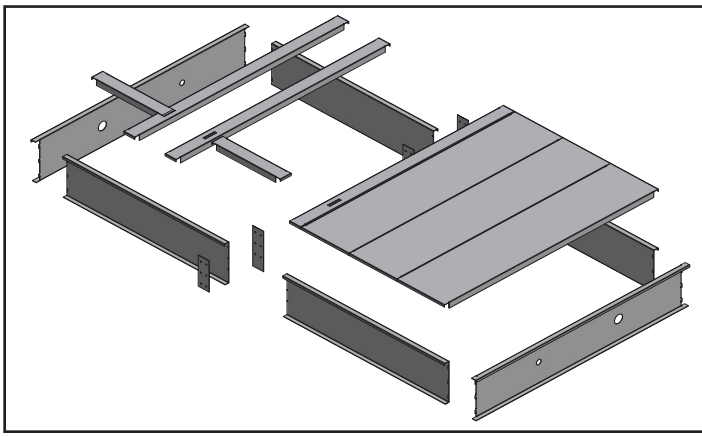

Figure 1
INSTALLATION

1. Place assembled curb in proper position over roof opening. Verify curb is square and level per instructions above.
2. Attach curb to roof surface following industry accepted practices.
3. Install insulation, cant strip, roofing materials, flashing and counterflashing in accordance with the established guidelines of the National Roofing Contractors Association. The finished roof, including counterflashing around the curb, must be installed prior to setting the unit on the curb.

VERTICAL DISCHARGE DUCT CONNECTIONS

The down flow curb accessory has been designed to encourage duct installation before unit placement. Duct installation after the unit placement is possible but not recommended. Ducts must never be fastened to the bottom of the unit causing the base pan to be penetrated. Flexible duct connectors in the ducts near the unit are recommended. Support all ducts by securing them to the building structure. Weatherproof all external ductwork, joints and roof openings with flashing and mastic in accordance with applicable codes. Ducts in an unconditioned space must be insulated and covered with a vapor barrier.

PARTS LIST

- 4) 60.8125" Sides w/ attached 1X4 wood nailer
- 2) 79 Sides w/ attached 1X4 wood nailer
- 4) 13.125" Insulated panels
- 3) 79" Duct support channel
- 1) 28.5" Duct support channel
- 1) 30" Duct support channel
- 3) Rolls T1070 1/4X1 gasket tape
- 4) 12 Gauge Brackets
- 1) Nut and Bolt Package

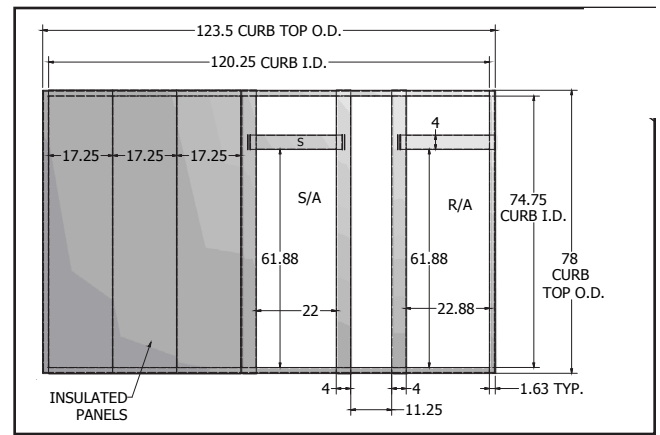

Figure 2

DOWNFLOW DUCT INSTALLATION INSTRUCTIONS

1. Install duct support system in leveled and squared curb.
2. Fabricate ductwork with 1 1/2" flange out on top opening and with an outside dimension that is 1/4" smaller than inside dimension of duct openings created by duct support system.

NOTE: Ductwork is to be furnished by the contractor and is not included with the accessory.

3. Drop duct section through duct support opening so that the 1 1/2" flange out rests on the support channel.

NOTE: It is not necessary to attach the duct to the duct supports with a mechanical fastener.

4. Install the included gasket material around the perimeter of the duct openings and around the top perimeter of the rest of the curb to insure an air tight seal.

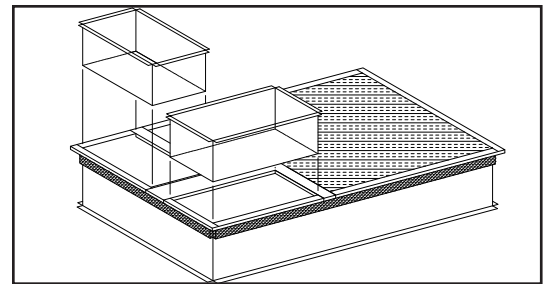

Demonstration only. Actual duct configuration may vary

DUCT INSTALLATION AFTER UNIT PLACEMENT

Duct installation after the unit has been placed is possible but is strongly discouraged. If the ductwork must be installed after the unit is placed on the curb, a duct connection frame system should still be used. Apply gasket material to the curb and duct support frame before installing the unit. Attach duct sections to the vertical surfaces of the duct support frame using mechanical fasteners. Ducts must never be fastened to the bottom of the unit causing the base pan to be penetrated.