

Gas-Fired Power Vented Unit Heaters Propeller & Blower Models



MODEL HD



MODEL HDB



MODEL PDP



MODEL BDP

Modine's power vented unit heaters are designed for the heating requirements of commercial and industrial buildings with select models available for residential garage heating as well.

For locations where negative pressure may be an issue or energy savings over older gravity vented units may be desired, Modine power vented gas fired unit heaters are your solution.

With 13 propeller and 11 blower model sizes available, the units cover a wide variety of applications with input ranges from 30,000 to 400,000 Btu/Hr in either natural or propane gas. This catalog describes the design benefits, construction features, performance data, unit selection procedure, and the optional and accessory devices available.

Table of Contents	Page
Design Features - All Models	3
Design Features - Model HD/HDB	4
Design Features - Model PDP/BDP	5
General Performance Data - Propeller Models HD/PDP	6
General Performance Data - Blower Models HDB/BDP	7
Blower Performance Data - Blower Model HDB	8
Blower Performance Data - Blower Model BDP	9-11
Gas Control Data - All Models	12
Field Installed Accessories	13
Downturn Hood Performance Data - Propeller Models HD/PDP	14
Velocity Generating Nozzle Performance Data - Blower Model BDP	15
Unit Selection	16-17
Dimensional Data - Models HD/HDB	18
Dimensional Data - Model PDP	19
Dimensional Data - Model BDP	20
Specifications - Models PDP/BDP	21-22
Model Nomenclature - All Models	23

WARNING

Do not locate ANY gas-fired unit in areas where chlorinated, halogenated or acid vapors are present in the atmosphere.

WARNING

Do not install in potentially explosive or flammable atmosphere laden with dust, sawdust, or similar airborne materials.

As Modine Manufacturing Company has a continuous product improvement program, it reserves the right to change design and specifications without notice.

Tubular Heat Exchanger Power Vented Unit Heaters, 30-125MBH

For residential, commercial or industrial applications that require a low profile unit, Modine offers the Hot Dawg®. Capable of being installed just one inch below the ceiling, the superior quality of the Hot Dawg makes it a preferred choice for a variety of applications, including garages and workshops.

Figure 2.1 - Hot Dawg Propeller Unit Heater

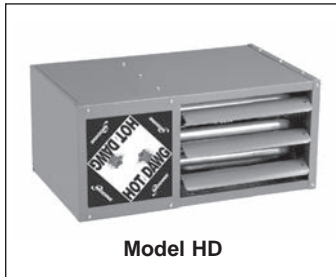
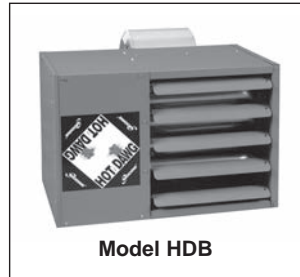

Figure 2.2 - Hot Dawg Blower Unit Heater



Power Vented Unit Heater, 150-400MBH

For commercial or industrial applications that require higher input ratings, the PDP/BDP is available in ratings that range from 150,000 to 400,000 Btu/Hr in either natural or propane gas.

Figure 2.3 - Propeller Unit Heater

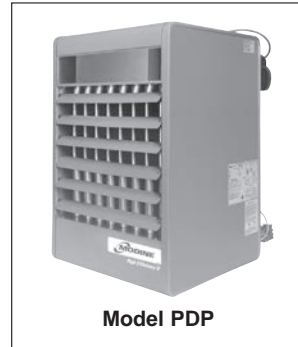

Figure 2.4 - Blower Unit Heater

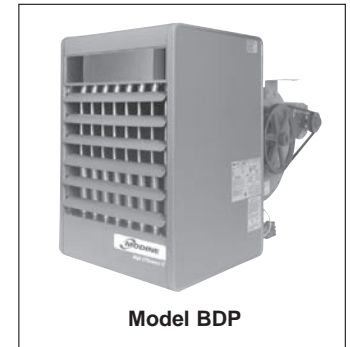
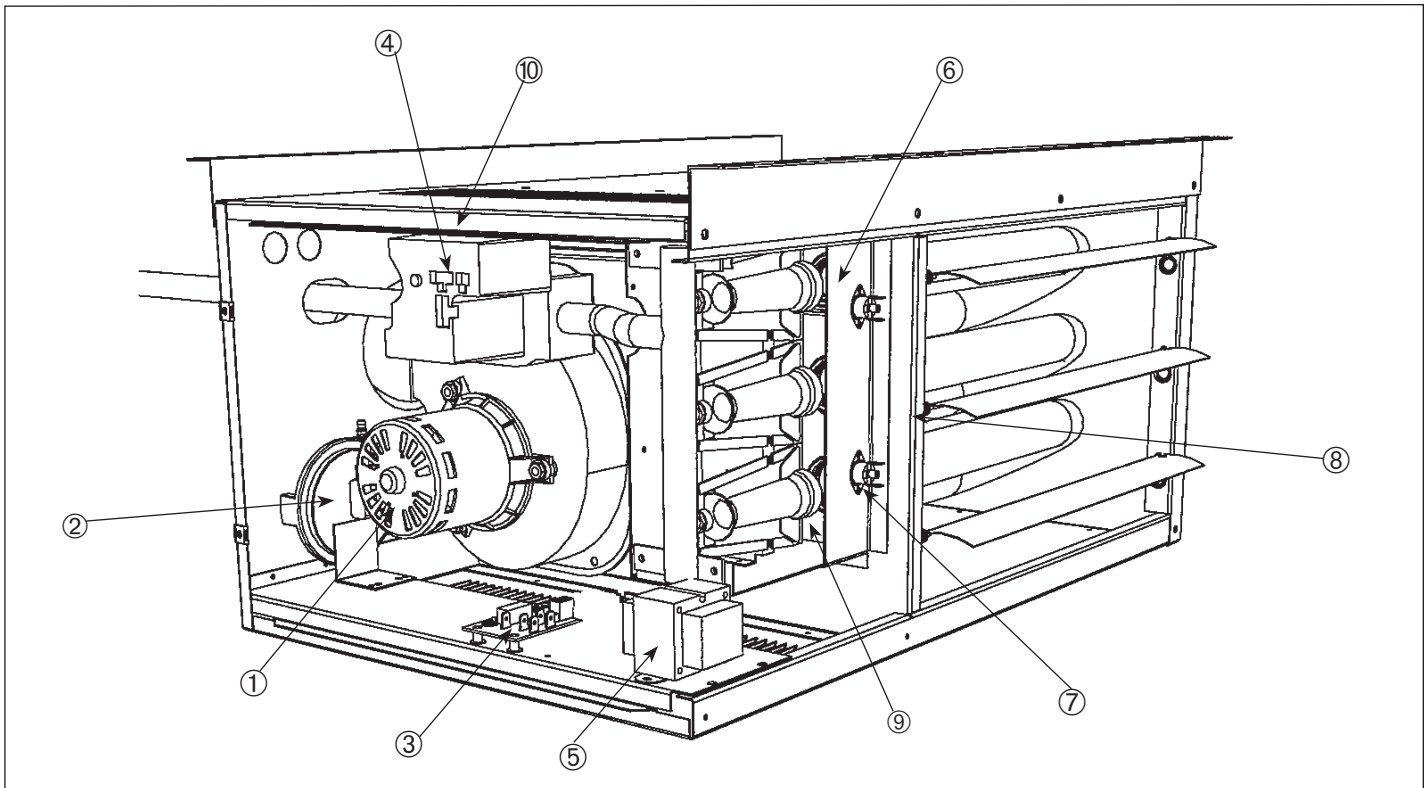

Table 3.1 - Standard Features and Factory Options ①

	Feature	Model			
		HD	HDB	PDP	BDP
Cabinet and Air Mover	Aluminized steel cabinet (gauge indicated)	22 ga.	22 ga.	20 ga.	20 ga.
	Low profile casing design	•	•		
	Baked-on polyester powder paint for durability and corrosion resistance	•	•	•	•
	Adjustable air-deflector blades	•	•	•	•
	Fans engineered for quiet operation	•	•	•	•
	Totally enclosed fan/blower motors (model sizes 100 and above)	•		•	•
	Fingerproof fan guard (optional on PDP units)	•	•	•	
	Two L-shaped mounting brackets (optional on sizes 100/125)	•	•		
	Adjustable mounting brackets for level hanging			•	•
	Hinged tool-less bottom pan entry			•	•
	Multi-tap 3-speed motors, certified to 0.8" W.C. external static pressure		•		
	Adjustable motor sheaves, certified to 0.5" W.C. external static pressure				•
Heat Exchanger and Burner	80% thermally efficient	•	•	•	•
	Aluminized steel heat exchanger (409 stainless steel optional)	•	•	•	•
	Tubular heat exchanger	•	•		
	In-shot burner on each heat exchanger tube for reliable performance, ease of serviceability and low sound level on flame ignition/extinction	•	•		
	Aluminized steel burner (409 stainless steel optional)			•	•
Controls	CSA certification for commercial and industrial use in the US and Canada	•	•	•	•
	CSA certification for residential use in the US and Canada	•	•		
	Factory-installed power exhauster	•	•	•	•
	Controls for natural gas (propane optional)	•	•	•	•
	Single stage gas controls (two stage optional)	•	•	•	•
	High limit safety control	•	•	•	•
	Differential pressure switch for proof of venting	•	•	•	•
	Flame roll-out safety switch	•	•		
	Direct spark ignition with continuous retry control system	•	•		
	Intermittent pilot ignition with continuous retry control system			•	•
	Control terminal board and low voltage terminal connections	•	•	•	•
	Gas control step down transformer with 24V gas controls	•	•	•	•
	Fan delay timer	•	•	•	•

① See page 13 for Field Installed Accessories

Figure 4.1 - Factory Mounted Standard and Optional Features (Models HD/HDB)



- ① **Power Exhauster (STD)**
All HD series (low profile) unit heaters are supplied with a round vent pipe connection.
- ② **Pressure Switch (STD)**
An automatic reset vent pressure switch is supplied on all HD series (low profile) unit heaters and is designed to prevent operation of the main burner in the event there is restricted venting of flue products. This restriction may occur due to an improper vent diameter, long vent runs, un-approved vent terminal, high winds, high negative pressure within space, etc. After the cause of the restriction has been corrected, the pressure switch will reset automatically. See the trouble shooting section of the installation and service manual for more information.
- ③ **Integrated Direct Spark Control Board (STD)**
The integrated direct spark ignition control combines all furnace control functions. The integrated board provides digital control of the air mover, inducer, ignition, gas valve and flame sense as well as monitoring the safety circuit at all times. The board includes LED diagnostics for trouble shooting and a fused power supply.
- ④ **Gas Valve - (See Table 12.2)**
 - a) **Single Stage Gas Valve - (STD)**
The main gas valve is factory installed on the unit heater gas train. The main gas valve provides regulator, main gas, and manual shutoff functions. The valve is redundant and provides 100% shut off.
 - b) **Two Stage Gas Valve - (OPT)**
The two-stage gas valve is factory installed on the unit heater gas train. The two stage gas valve provides the regulator, main gas (100% and 50% fire), and manual shutoff functions. The valve is redundant and provides 100% shut off.
- ⑤ **Control Step Down Transformer - (STD)**
The control step down transformer is located in the electrical junction box. The transformer is used to step down the supply power (115V, 208V, 230V, 460V, 575V) to 24V for the gas controls, fan delay relay, field supplied motor starter, etc. To determine the control transformer supplied as well as any accessory/field supplied transformers required, refer to Table 12.1
- ⑥ **Flame Sensor – (hidden, STD)**
Remote flame sensor verifies ignition of all burners, monitors the flame signal and communicates with the integrated circuit board.
- ⑦ **Flame Roll Out Switch - (STD)**
Flame roll out switches are mounted near the burners and will shut off the gas supply in the event of an unsafe flame roll out condition.
- ⑧ **Auto High Limit Switch - (hidden, STD)**
The limit control is mounted in the air stream and will shut off the gas supply in the event of overheating.
- ⑨ **Direct Spark Igniter - (hidden, STD)**
Provides spark for direct ignition of the burners.
- ⑩ **Manual Reset Control - (hidden, propeller 100-125 only)**

Figure 5.1 - Factory Mounted Standard and Optional Features (Models PDP/BDP)

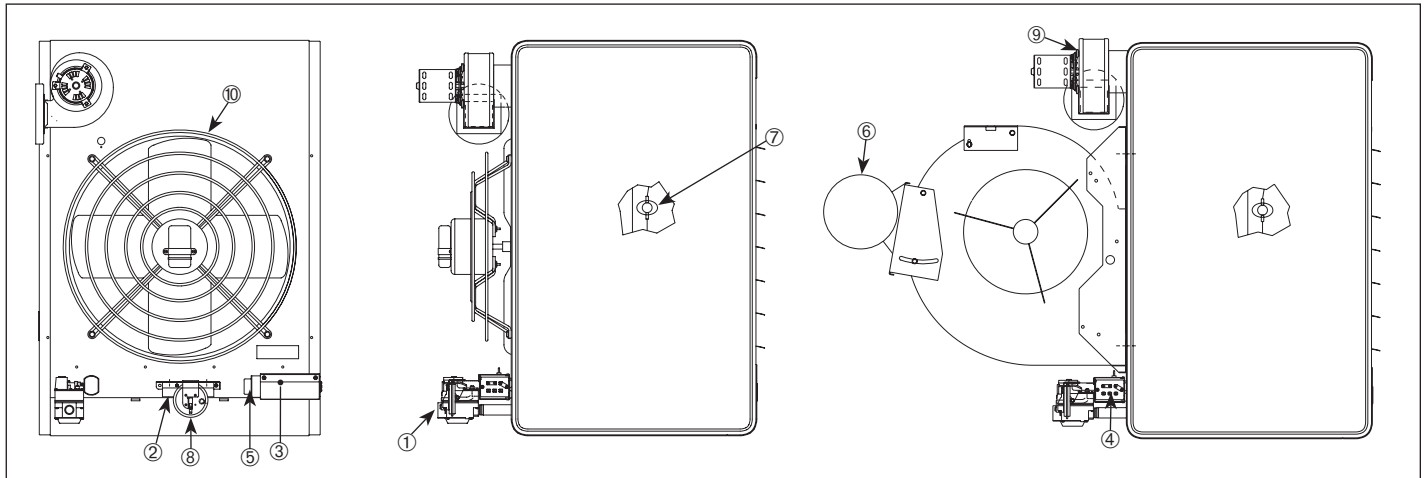

All units include the standard (STD) features, and may include the optional (OPT) features shown.

① **Gas Valve (See Table 12.2)**

a) Single Stage Gas Valve - (STD)

The main gas valve is factory installed on the unit heater gas train. The main gas valve provides the pilot, regulator, main gas, and manual shutoff functions.

b) Two Stage Gas Valve - (OPT)

The two-stage gas valve is factory installed on the unit heater gas train. The two stage gas valve provides the pilot, regulator, main gas (100% and 50% fire), and manual shutoff functions. See the supplier literature included with the unit.

② **Ignition controller - (STD)**

The ignition controller is factory installed on the back of the unit heater with the spark igniter and sensor located on the burner. For both natural and propane gas units, the ignition controller is 100% shut-off with continuous retry. On a call for heat, the system will attempt to light the pilot for 70 seconds. If the pilot is not sensed for any reason, the ignition control will wait for approximately six minutes with the combination gas control closed and no spark. After six minutes, the cycle will begin again. After three cycles, some ignition controllers lockout for approximately one hour before the cycle begins again. This will continue indefinitely until the pilot flame is sensed or power is interrupted to the system.

③ **Time Delay Relay - (STD on all but Mech. Mod.)**

The time delay relay is factory installed in electrical junction box. The time delay relay allows the gas controls to operate for approximately 30 to 90 seconds before the blower starts. This allows the heat exchanger a warm up period so that the initial delivered air is not cool. The time delay relay also keeps the motor running for approximately 30 - 90 seconds after the call for heat has been satisfied to remove the residual heat from the heat exchanger.

Note: Mechanical modulation units are used on make-up air only and do not require or include time delay relays.

④ **Low Voltage Terminal Board - (STD)**

The low voltage terminal board is located in electrical junction box. The terminal board is labeled to match the electrical wiring diagram provided with the unit.

⑤ **Control Step Down Transformer - (STD)**

The control step down transformer is located in the electrical junction box. The transformer is used to step down the supply power (115V, 208V, 230V, 460V, 575V) to 24V for the gas controls, fan delay relay, field supplied motor starter, etc. To determine the control transformer supplied as well as any accessory/field supplied transformers required, refer to Table 12.1

⑥ **Blower Motor - (OPT)**

The blower motor is factory installed on the blower housing. The blower motor can be provided in a variety of supply voltages and motor horsepower. The blower motor is supplied with an adjustable sheave that can be used to increase/decrease the blower RPM.

⑦ **High Limit Switch - (STD)**

The automatic reset high limit switch is factory installed on the side of the unit heater. If the limit temperature is exceeded, the gas controls are de-energized until the switch is cooled.

⑧ **Pressure Switch (STD)**

A automatic reset vent pressure switch is supplied on all power vented unit heaters to prevent operation of the main burner in the event there is restricted venting of flue products. This restriction may occur due to an improper vent diameter, long vent runs, un-approved vent terminal, high winds, high negative pressure within space, etc. After the cause of the restriction has been corrected, the pressure switch will reset automatically.

⑨ **Power Exhauster (STD)**

All power vented unit heaters are supplied with a round vent pipe connection. The power exhauster may be rotated 180° to allow for various venting directions.

⑩ **Finger Proof Fan Guard (OPT)**

Propeller units may be equipped with an optional finger proof fan guard for added protection. The finger proof fan guard is installed at the factory in place of the standard fan guard. Standard fan guard is shown.

Table 6.1 - Propeller Unit Model HD and PDP General Performance Data

	Model HD Sizes						Model PDP Sizes						
	30	45	60	75	100	125	150	175	200	250	300	350	400
Btu/Hr Input ①	30,000	45,000	60,000	75,000	100,000	125,000	150,000	175,000	200,000	250,000	300,000	350,000	400,000
Btu/Hr Output ①	24,000	36,000	48,000	60,000	80,000	100,000	120,000	140,000	160,000	200,000	240,000	280,000	320,000
Entering Airflow (CFM) @ 70°F	505	720	990	1160	1490	1980	2180	2550	2870	3700	4460	4870	5440
Outlet Velocity (FPM)	523	725	653	769	565	747	931	959	819	1053	1123	1068	1016
Air Temp. Rise (°F)	44	46	45	48	50	47	51	51	52	50	50	53	54
Max. Mounting Height (Ft.) ②	10	10	12	14	12	16	16	17	15	19	21	20	19
Heat Throw (Ft.) @ Max Mtg Ht ②	25	27	36	38	42	56	55	59	51	67	74	70	69
Motor Type ③	SP	SP	PSC	PSC	SP	PSC	PSC	PSC	PSC	PSC	PSC	PSC	PSC
Motor HP	1/15	1/15	1/12	1/12	1/12	1/8	1/8	1/6	1/6	1/3	1/2	3/4	3/4
Motor RPM	1550	1550	1625	1625	1050	1625	1625	1075	1075	1075	1075	1125	1125

Table 6.2 - Propeller Unit Model HD and PDP Operating Electrical Data

Supply Voltage	Power Code		Model HD Sizes						Model PDP Sizes						
			30	45	60	75	100	125	150	175	200	250	300	350	400
115V 1 Phase	01 (115V)	Motor Amps	2.4	2.4	1.2	1.2	2.7	2.2	2.3	2.7	2.7	5.4	7.5	8.8	8.8
		Total Amps	3.7	3.7	2.5	2.5	4.7	4.2	4.0	5.1	5.1	7.7	9.8	11.1	11.1
		Transformer kVA	n/a	n/a	n/a	n/a	n/a	n/a	n/a	n/a	n/a	n/a	n/a	n/a	n/a
208V 1 Phase	01 (115V) with Transformer	Transformer kVA	0.5	0.5	0.5	0.5	1.0	1.0	0.5	1.0	1.0	1.0	1.5	1.5	1.5
		208V Total Amps	2.05	2.05	1.38	1.38	2.60	2.32	2.21	2.82	2.82	4.26	5.42	6.14	6.14
	03 (208V)	Motor Amps	n/a	n/a	n/a	n/a	n/a	n/a	1.0	1.5	1.5	n/a	n/a	n/a	n/a
		Total Amps	n/a	n/a	n/a	n/a	n/a	n/a	1.9	2.8	2.8	n/a	n/a	n/a	n/a
230V 1 Phase	01 (115V) with Transformer	Transformer kVA	0.5	0.5	0.5	0.5	0.75	0.75	0.5	0.75	0.75	1.0	1.5	1.5	1.5
		230V Total Amps	1.85	1.85	1.25	1.25	2.35	2.10	2.00	2.55	2.55	3.85	4.90	5.55	5.55
	02 (230V)	Motor Amps	n/a	n/a	n/a	n/a	n/a	n/a	1.0	1.5	1.5	2.5	3.5	4.4	4.4
		Total Amps	n/a	n/a	n/a	n/a	n/a	n/a	1.9	2.8	2.8	3.7	4.7	5.5	5.5
208V 3 Phase	01 (115V) with Transformer	Transformer kVA	0.5	0.5	0.5	0.5	1.0	1.0	0.5	1.0	1.0	1.0	1.5	1.5	1.5
		208V Total Amps	2.05	2.05	1.38	1.38	2.60	2.32	2.21	2.82	2.82	4.26	5.42	6.14	6.14
230V 3 Phase	01 (115V) with Transformer	Transformer kVA	0.5	0.5	0.5	0.5	0.75	0.75	0.5	0.75	0.75	1.0	1.5	1.5	1.5
		230V Total Amps	1.85	1.85	1.25	1.25	2.35	2.10	2.00	2.55	2.55	3.85	4.90	5.55	5.55
460V 3 Phase	01 (115V) with Transformer	Transformer kVA	0.5	0.5	0.5	0.5	0.75	0.75	0.5	0.75	0.75	1.0	1.5	1.5	1.5
		460V Total Amps	0.93	0.93	0.63	0.63	1.18	1.05	1.00	1.28	1.28	1.93	2.45	2.78	2.78
575V 3 Phase	01 (115V) with Transformer	Transformer kVA	0.5	0.5	0.5	0.5	0.75	0.75	0.5	0.75	0.75	1.0	1.5	1.5	1.5
		575V Total Amps	0.74	0.74	0.50	0.50	0.94	0.84	0.80	1.02	1.02	1.54	1.96	2.22	2.22

① Ratings shown are for elevations up to 2,000 ft. For elevations above 2,000 feet, ratings should be reduced at the rate of 4% for each 1,000 feet above sea level. (In Canada see rating plate.) Reduction of ratings requires use of a high altitude kit.
 ② Data taken at 55°F air temperature rise. At 65°F ambient and unit fired at full-rated input. Mounting height as measured from bottom of unit, and without deflector hoods.
 ③ All motors used are produced, rated and tested by reputable manufacturers in accordance with NEMA standards and carry the standard warranty of both the motor manufacturer and Modine. Motors on model sizes 100 and above are totally enclosed (model size 75 and below are open drip proof) and all single phase motors have built in thermal overload protection.

Table 7.1 - Blower Unit Model HDB and BDP General Performance Data

	Model HDB Sizes				Model BDP Sizes						
	60	75	100	125	150	175	200	250	300	350	400
Btu/Hr Input ①	60,000	75,000	100,000	125,000	150,000	175,000	200,000	250,000	300,000	350,000	400,000
Btu/Hr Output ①	48,000	60,000	80,000	100,000	120,000	140,000	160,000	200,000	240,000	280,000	320,000
Entering Airflow Range (CFM)	635-1111	794-1389	1140-2116	1235-2058	1587-2778	1852-3241	2116-3704	2646-4630	3175-5556	3704-6481	4233-6584
Outlet Velocity (FPM)	437-726	546-908	443-781	488-773	869	892	773	966	1026	1037	1008
Air Temp. Rise (°F)	40-70	40-70	35-65	45-75	40-70	40-70	40-70	40-70	40-70	40-70	40-70
Max. Mounting Height (Ft.) ②	7-13	7-16	8-19	8-17	14	15	13	16	18	19	19
Heat Throw (Ft.) @ Max Mtg Ht ②	20-45	24-57	27-68	27-59	49	52	47	58	64	67	68
Motor Type ③	P.S.C.	P.S.C.	P.S.C.	P.S.C.	T.E	T.E	T.E	T.E	T.E	T.E	T.E
Motor HP	1/4	1/3	1/2	1/2	See Table 9.1						
Motor RPM	Max 1100	Max 1100	Max 1100	Max 1100	1725	1725	1725	1725	1725	1725	1725

Table 7.2 - Blower Unit Model HDB Operating Electrical Data

Supply Voltage	Power Code		Model HDB Sizes				Model BDP Sizes					
			60	75	100	125	150	175	200	250	300	350
115V 1 Phase	01 (115V)	Motor Amps	5.4	7.1	9.5	9.5	See Table 7.3					
		Total Amps	6.4	8.1	11.5	11.5						
		Transformer kVA	n/a	n/a	n/a	n/a						
208V 1 Phase	01 (115V) with Transformer	Transformer kVA	1.0	1.0	1.5	1.5						
		208V Total Amps	3.54	4.48	6.36	6.36						
230V 1 Phase	01 (115V) with Transformer	Transformer kVA	1.0	1.0	1.5	1.5						
		230V Total Amps	3.20	4.05	5.75	5.75						
208V 3 Phase	01 (115V) with Transformer	Transformer kVA	1.0	1.0	1.5	1.5						
		208V Total Amps	3.54	4.48	6.36	6.36						
230V 3 Phase	01 (115V) with Transformer	Transformer kVA	1.0	1.0	1.5	1.5						
		230V Total Amps	3.20	4.05	5.75	5.75						
460V 3 Phase	01 (115V) with Transformer	Transformer kVA	1.0	1.0	1.5	1.5						
		460V Total Amps	1.60	2.03	2.88	2.88						
575V 3 Phase	01 (115V) with Transformer	Transformer kVA	1.0	1.0	1.5	1.5						
		575V Total Amps	1.28	1.62	2.30	2.30						

Table 7.3 - Blower Unit Model BDP Operating Electrical Data

Voltage		115/60/1			230/60/1			208/60/3			230/60/3			460/60/3			575/60/3		
HP	Motor Rpm	Motor Amps	Total Amps	Total Watts	Motor Amps	Total Amps	Total Watts	Motor Amps	Total Amps	Total Watts	Motor Amps	Total Amps	Total Watts	Motor Amps	Total Amps	Total Watts	Motor Amps	Total Amps	Total Watts
1/4	1725	3.7	6.0	696	2.7	4.0	914	1.3	2.6	539	1.2	2.5	569	0.7	1.9	592	0.5	1.8	569
1/3	1725	5.0	7.3	845	2.5	3.8	868	1.2	2.5	518	1.2	2.5	569	0.6	1.9	569	0.8	2.1	753
1/2	1725	8.0	10.3	1190	4.0	5.3	1213	2.2	3.5	726	2.1	3.4	776	1.1	2.4	799	0.9	2.2	811
3/4	1725	11.0	13.3	1535	5.4	6.7	1535	2.8	4.1	851	2.7	4.0	914	1.4	2.6	937	1.1	2.3	926
1	1725	13.4	15.7	1811	6.7	8.0	1834	3.6	4.9	1018	3.5	4.8	1098	1.8	3.0	1121	1.5	2.6	1127
1-1/2	1725	15.2	17.5	2018	7.6	8.9	2041	4.8	6.1	1267	4.8	6.1	1397	2.4	3.6	1397	1.9	3.1	1386
2	1725	---	---	---	---	---	---	6.8	8.1	1683	6.0	7.3	1673	3.0	4.3	1673	2.3	3.5	1616
3	1725	---	---	---	---	---	---	9.9	11.2	2328	8.2	9.5	2179	4.1	5.4	2179	3.4	4.6	2248
5	1725	---	---	---	---	---	---	15.2	16.5	3430	13.0	14.3	3283	6.5	7.8	3283	5.3	6.5	3341

① Ratings shown are for elevations up to 2,000 ft. For elevations above 2,000 feet, ratings should be reduced at the rate of 4% for each 1,000 feet above sea level. (In Canada see rating plate.)
Reduction of ratings requires use of a high altitude kit.
② Data taken at 55°F air temperature rise. At 65°F ambient and unit fired at full-rated input. Mounting height as measured from bottom of unit, and without deflector hoods.
③ All motors used are produced, rated and tested by reputable manufacturers in accordance with NEMA standards and carry the standard warranty of both the motor manufacturer and Modine. Model HDB motors are open drip proof, while model BDP motors are totally enclosed and all single phase motors have built-in thermal overload protection.

Table 8.1 - Power Code Description - HDB Models

Power Code	Unit Voltage	HDB60	HDB75	HDB100	HDB125
01	115/60/1	1/4 HP	1/3 HP	1/2 HP	1/2 HP

Blower Speed Curves Models (HDB 60-125)

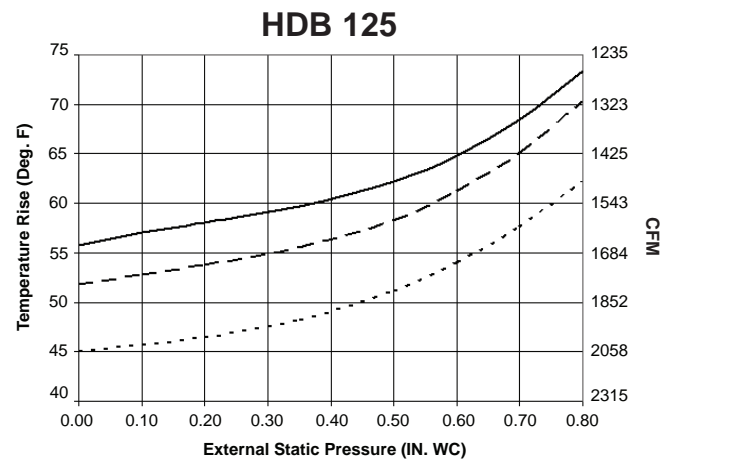
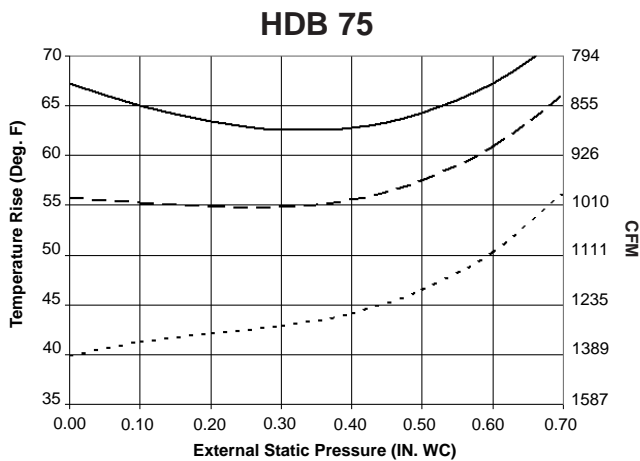
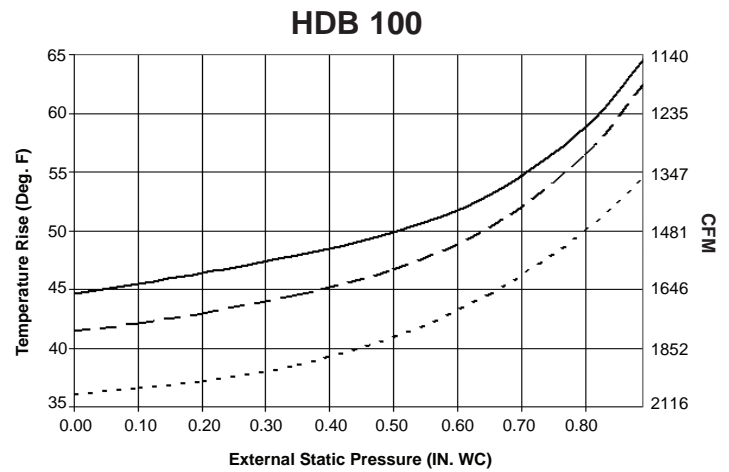
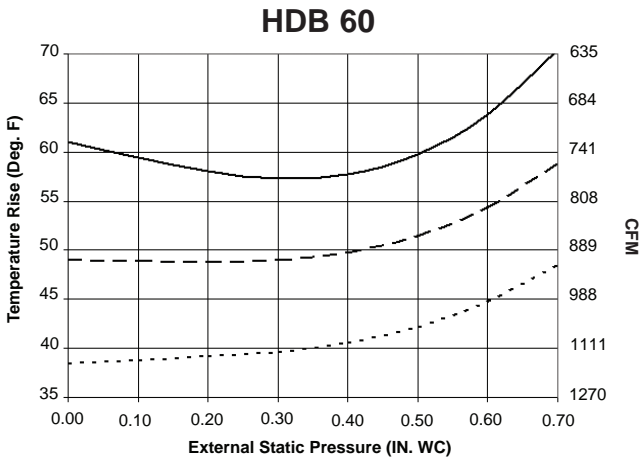
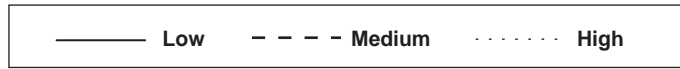

BLOWER PERFORMANCE DATA - MODEL BDP



Table 9.1 - Power Code Description — Blower Model BDP ①

Power Code	Voltage	Phase	150		175		200		250		300		350		400	
			HP	Drive	HP	Drive	HP	Drive	HP	Drive	HP	Drive	HP	Drive	HP	Drive
01	115	1	1/4	191	-	-	1/4	212	-	-	-	-	-	-	-	-
02	230	1	1/4	191	-	-	1/4	212	-	-	-	-	-	-	-	-
04	208	3	1/4	191	-	-	1/4	212	-	-	-	-	-	-	-	-
05	230/460	3	1/4	191	-	-	1/4	212	-	-	-	-	-	-	-	-
07	575	3	1/4	197	-	-	1/4	213	-	-	-	-	-	-	-	-
09	115	1	1/3	191	1/3	95	1/3	212	1/3	203	3/4	205	1	107	1-1/2	105
10	230	1	1/3	191	1/3	95	1/3	212	1/3	203	3/4	205	1	107	1-1/2	105
12	208	3	1/3	191	1/3	95	1/3	212	1/3	203	3/4	205	1	107	1-1/2	105
13	230/460	3	1/3	191	1/3	95	1/3	212	1/3	203	3/4	205	1	255	1-1/2	180
15	575	3	1/3	197	1/3	96	1/3	213	1/3	204	3/4	205	1	107	1-1/2	180
17	115	1	1/3	95	1/2	96	1/3	102	1/2	204	1	205	1-1/2	105	-	-
18	230	1	1/3	95	1/2	96	1/3	102	1/2	204	1	205	1-1/2	105	-	-
20	208	3	1/3	95	1/2	96	1/3	102	1/2	204	1	205	1-1/2	105	2	210
21	230/460	3	1/3	95	1/2	96	1/3	102	1/2	204	1	157	1-1/2	180	2	210
23	575	3	1/3	96	1/2	96	1/3	101	1/2	204	1	205	1-1/2	180	2	210
25	115	1	1/2	96	3/4	192	1/2	101	3/4	205	1-1/2	106	1-1/2	100	-	-
26	230	1	1/2	96	3/4	192	1/2	101	3/4	205	1-1/2	106	1-1/2	100	-	-
28	208	3	1/2	96	3/4	192	1/2	101	3/4	205	1-1/2	106	1-1/2	100	3	111
29	230/460	3	1/2	96	3/4	192	1/2	101	3/4	205	1-1/2	108	1-1/2	33	3	111
31	575	3	1/2	96	3/4	192	1/2	101	3/4	205	1-1/2	108	1-1/2	210	3	111
33	115	1	3/4	38	1	192	3/4	16	1	205	-	-	-	-	-	-
34	230	1	3/4	38	1	192	3/4	16	1	205	-	-	-	-	-	-
36	208	3	3/4	38	1	192	3/4	16	1	205	2	108	2	210	5	207
37	230/460	3	3/4	38	1	256	3/4	16	1	157	2	108	2	210	5	207
39	575	3	3/4	38	1	192	3/4	16	1	205	2	108	2	210	5	207
41	115	1	1	38	1-1/2	193	1	16	1-1/2	105	-	-	-	-	-	-
42	230	1	1	38	1-1/2	193	1	16	1-1/2	105	-	-	-	-	-	-
44	208	3	1	38	1-1/2	193	1	16	1-1/2	105	3	111	3	111	2	80
45	230/460	3	1	254	1-1/2	198	1	178	1-1/2	180	3	111	3	111	2	80
47	575	3	1	38	1-1/2	198	1	16	1-1/2	180	3	111	3	111	2	80
49	115	1	1/4	13	-	-	1-1/2	105	-	-	1-1/2	105	-	-	-	-
50	230	1	1/4	13	-	-	1-1/2	105	-	-	1-1/2	105	-	-	-	-
52	208	3	1/4	13	2	80	1-1/2	105	2	108	1-1/2	105	5	207	3	112
53	230/460	3	1/4	13	2	80	1-1/2	180	2	108	1-1/2	180	5	207	3	112
55	575	3	1/4	14	2	80	1-1/2	180	2	108	1-1/2	180	5	207	3	112
57	115	1	3/4	96	3/4	96	1/4	24	3/4	204	-	-	-	-	-	-
58	230	1	3/4	96	3/4	96	1/4	24	3/4	204	-	-	-	-	-	-
60	208	3	3/4	96	3/4	96	1/4	24	3/4	204	-	-	2	80	5	111
61	230/460	3	3/4	96	3/4	96	1/4	24	3/4	204	-	-	2	80	5	111
63	575	3	3/4	96	3/4	96	1/4	25	3/4	204	-	-	2	80	5	111
65	115	1	-	-	1-1/2	79	1/3	24	1-1/2	23	-	-	-	-	-	-
66	230	1	-	-	1-1/2	79	1/3	24	1-1/2	23	-	-	-	-	-	-
68	208	3	-	-	1-1/2	79	1/3	24	1-1/2	23	-	-	5	81	-	-
69	230/460	3	-	-	1-1/2	80	1/3	24	1-1/2	177	-	-	5	81	-	-
71	575	3	-	-	1-1/2	80	1/3	25	1-1/2	177	-	-	5	81	-	-
73	115	1	-	-	-	-	1/2	25	-	-	-	-	-	-	-	-
74	230	1	-	-	-	-	1/2	25	-	-	-	-	-	-	-	-
76	208	3	-	-	-	-	1/2	25	-	-	-	-	-	-	-	-
77	230/460	3	-	-	-	-	1/2	25	-	-	-	-	-	-	-	-
79	575	3	-	-	-	-	1/2	25	-	-	-	-	-	-	-	-
81	115	1	-	-	-	-	3/4	101	-	-	-	-	-	-	-	-
82	230	1	-	-	-	-	3/4	101	-	-	-	-	-	-	-	-
84	208	3	-	-	-	-	3/4	101	-	-	-	-	-	-	-	-
85	230/460	3	-	-	-	-	3/4	101	-	-	-	-	-	-	-	-
87	575	3	-	-	-	-	3/4	101	-	-	-	-	-	-	-	-
89	115	1	-	-	-	-	1-1/2	23	-	-	-	-	-	-	-	-
90	230	1	-	-	-	-	1-1/2	23	-	-	-	-	-	-	-	-
92	208	3	-	-	-	-	1-1/2	23	-	-	-	-	-	-	-	-
93	230/460	3	-	-	-	-	1-1/2	177	-	-	-	-	-	-	-	-
95	575	3	-	-	-	-	1-1/2	177	-	-	-	-	-	-	-	-

① For selection of correct Power Code, refer to the Tables on pages 10-11.

BLOWER PERFORMANCE DATA - MODEL BDP



Blower Model BDP

Models With or Without Blower Enclosure

Model Size	ATR	CFM	0.0" Static Press.				0.1" Static Press.				0.2" Static Press.				0.3" Static Press.				0.4" Static Press.					
			RPM	HP	Drive	Turns	RPM	HP	Drive	Turns	RPM	HP	Drive	Turns	RPM	HP	Drive	Turns	RPM	HP	Drive	Turns		
150	40	2778	515	1/2	96	4.0	565	3/4	38	4.5	615	3/4	38	4.0	665	3/4	38	3.0	705	1	38	2.0		
	45	2469	455	1/3	191	0.0	515	1/2	96	4.0	570	1/2	96	3.0	620			3.5	670	3/4		96	3.0	
	50	2222	410	1/4		1.5	475	1/3	95	5.0	535			3.5	590			2.5	640				3.0	615
	55	2020	375		2.5	445	1/4	191	0.5	505	1/3	95	4.0	565	3.0	615	2.0							
	60	1852	345		3.5	420			1.0	485			4.5	545	3.5	600	1/2	96	3.5	600	1/2	96	2.5	
	65	1709	315		4.0	400			2.0	470			5.0	530	1/3	95	4.0	575	1/3	95	4.0	575	1/3	95
	70	1587	295		5.0	380			2.5	455	1/4	191	0.0	520	3.0	630	1/2	96	2.0	680	1/2	96	1.0	
175	40	3241	805	1-1/2	193	3.5			840	1-1/2	193	2.5	875	1-1/2	193	2.0	910	1-1/2	193	1.0	940	1-1/2	193	0.0
	45	2881	715	1	192	4.0	755	1	192	3.5	795	1	192	3.0	830	3.0	865			1-1/2	193	2.0		
	50	2593	645	3/4		5.0	690	3/4		96	4.5	730		3/4	192	4.0	770	1	192	3.5	810	1	192	3.0
	55	2357	585	1/2	96	2.5	635	1/2	96	1.5	680	1/2	96			4.5	720	3/4		192	4.0	765		3/4
	60	2160	540	1/3	95	3.5	590			2.5	640			1/3	95	2.5	640	1.5	685	1/2	96	4.5	730	4.5
	65	1994	495			4.5	550	3.5	605	2.5	655	1.5	700			1/2	96	1.5	700			1/2	96	0.5
	70	1852	460			5.0	520	4.0	575	1/3	95	3.0	630			2.0	680	2.0	680			1/2	96	2.0
200	40	3704	420	3/4	16	5.0	465	3/4	16	4.0	505	1	16	3.0	540	1	16	2.0	580	1	16	1.0		
	45	3292	375	1/2	101	4.0	420	1/2	101	3.5	465	3/4		16	3.5	510		3/4	16	2.5		550	1	16
	50	2963	335	1/3	212	1.0	390			1/3	102	4.5	440	1/2	101	3.0	485	1/2	101	3.5	525	3/4	101	
	55	2694	305	2.0		365	1/3	102	5.0	415	3.5	465	2.5			510	2.5			510	3.0	500		1/2
	60	2469	280	3.0		345	1/4	212	0.5	400	1/3	102	4.0	450	1/2	101	3.0	490	3.0	490	1/2	101	2.0	
	65	2279	260	4.0		325			1.5	385			4.5	440	4.5	440	4.0	450	3.0	490	1/2	101	1.5	
	70	2116	240	5.0		310			2.0	375			5.0	430	1/3	102	3.5	485	2.0	680	1/2	96	2.0	
250	40	4630	605	1-1/2	105	4.5	635	1-1/2	105	3.5	665	1-1/2	105	3.0	690	2	105	4.0	720	2	105	3.0		
	45	4115	535	1	205	3.5	570	1	205	3.0	605			4.5	635	1-1/2		105	3.5	665		1-1/2	105	2.5
	50	3704	485	3/4		4.5	520	3/4		205	4.0	555	1	205	3.0	590	1	205	2.5	625	1-1/2	105	4.0	
	55	3367	440	2.0	480	5.0	520		4.0		555	3/4	205		4.5	530	3/4		205	3.0	595	1	205	2.5
	60	3086	405	3.0	450	1.5	490	4.5	530	4.0	555	1.0	510	3/4	205	4.0	570	3/4	205	3.0				
	65	2849	370	4.0	420	2.5	465	1.0	510	1.0	510	1/2	204	1.5	490	1/2	204	0.5	535	3/4	205	3.5		
	70	2646	345	4.5	395	1/3	203	3.0	445	1/2	204	1.5	490	1/2	204	0.5	535	3/4	205	3.5				
300	40	5556	825	3	111	3.0	850	3	111	2.5	875	3	111	2.0	900	3	111	1.0	-	-	-	-		
	45	4938	735	2	108	760	2	108	2.0	790	2	108	1.5	815	3.0	840	3	111	3.0	840	3	111	2.5	
	50	4444	660	1-1/2	106	5.0	690	1-1/2	106	4.0	720	1-1/2	106	3.0	750	2	108	2.5	780	2	108	1.5		
	55	4040	600	1	2.5	635	5.0			665	4.5			700	4.0	730		4.0	730	1-1/2		106	5.0	690
	60	3704	550	3.5	590	1	2.5	625	1	2.5	625	1	2.5	655	1-1/2	106	2.0	655	1-1/2	106	4.0			
	65	3419	510	4.0	550	3.5	585	3.5	585	2.5	620	1	205	2.5	620	1	205	2.0	655	1	205	1.0		
	70	3175	470	5.0	515	3/4	205	4.0	555	3/4	205	3.5	595	3/4	205	2.5	630	1	205	2.5	630	1	205	2.0
350	40	6481	960	5	207	2.5	880	3	111	1.5	905	3	111	1.0	930	5	207	3.0	955	5	207	0.5		
	45	5761	850	3	111	880	3	111	1.5	905	3	111	1.0	930	3.0	955	3.0	955	3.0	955	3.0	955	2.5	
	50	5185	765	2	210	4.5	795	3	111	3.5	825	3	111	3.0	850	3	111	2.5	880	3	111	1.5		
	55	4714	695	2.0	730	2	210	5.0	760	2	210	4.5	790	2	210	3.5	820	2	210	3.5	820	3.0		
	60	4321	640	3.5	675	1-1/2	105	2.5	710	1-1/2	105	1.5	740	1-1/2	105	0.5	770	1-1/2	105	0.5	770	4.0		
	65	3989	590	4.5	630	3.5	665	3.5	665	1-1/2	105	3.0	695	1-1/2	105	2.0	730	1-1/2	105	2.0	730	1.0		
	70	3704	550	5.0	590	1	107	4.5	625	1	107	3.5	660	1	107	3.0	695	1-1/2	105	3.0	695	2.0		
400	40	-	-	-	-	-	-	-	-	-	-	-	-	-	-	-	-	-	-	-	-	-		
	45	6584	885	5	207	4.0	915	5	207	3.5	940	5	207	3.0	965	5	207	2.5	985	5	207	2.0		
	50	5926	800	3	111	3.5	825	3	111	3.0	855	3	111	2.0	880	4.0	910	4.0	910	4.0	910	3.5		
	55	5387	725	2	210	5.0	760	4.5	790	4.5	790	4.0	815	3	111	3.0	845	3	111	3.0	845	2.5		
	60	4938	665	2.5	700	2	210	6.0	735	2	210	5.0	765	2	210	4.5	795	2	210	4.5	795	3.5		
	65	4558	615	4.0	650	3.0	685	3.0	685	1-1/2	105	2.0	720	1-1/2	105	5.0	750	1-1/2	105	5.0	750	4.5		
	70	4233	570	4.5	610	1-1/2	105	4.5	650	1-1/2	105	3.5	680	1-1/2	105	3.5	680	1-1/2	105	2.5	715	1-1/2	105	1.5

For 230/460V or 575V selections and footnotes, please see page 11.

BLOWER PERFORMANCE DATA - MODEL BDP



Blower Model BDP

Models With or Without Blower Enclosure ① ②

Model Size	ATR	CFM	Data for use with filters only														
			0.5" Static Press.				0.6" Static Press.				0.7" Static Press.						
			RPM	HP	Drive	Turns	RPM	HP	Drive	Turns	RPM	HP	Drive	Turns			
150	40	2778	750	1	38	1.5	-	-	-	-	-	-	-	-	-	-	
	45	2469	715			2.0	755	1	-	1.5	-	-	-	-	-	-	-
	50	2222	685			2.5	730	3/4	38	2.0	-	-	-	-	-	-	-
	55	2020	665	3.0	715	2.5	-			-	-	-	-	-	-		
	60	1852	650	1/2	96	1.5	700	3/4	38	2.0	-	-	-	-	-	-	
	65	1709	640			1.5	690			2.5	-	-	-	-	-	-	
	70	1587	630	2.0	680	1/2	96	1.0	-	-	-	-	-	-			
175	40	3241	970	2	80	2.5	1005	2	80	1.5	1035	2	80	1.0	-	-	
	45	2881	900	1-1/2	193	1.0	935	1-1/2	193	0.5	970			2.5	-	-	-
	50	2593	845	1	192	2.5	885	3/4	192	1.5	920	1-1/2	193	0.5	-	-	
	55	2357	805			3.0	845			1	880	1.5	-	-	-	-	
	60	2160	770			3.5	815	3/4	192	2.5	855	3/4	192	2.0	-	-	-
	65	1994	745	0.0	770	3.0	830			2.5	-			-	-	-	
	70	1852	725	1/2	96	0.0	770	3.5	815	3.0	815	2.5	-	-	-		
200	40	3704	615	1-1/2	105	4.0	650	1-1/2	105	3.0	-	-	-	-	-		
	45	3292	590	1	16	1.0	625			4.0	-	-	-	-	-		
	50	2963	570	3/4	16	1.5	610	3/4	16	0.5	-	-	-	-	-		
	55	2694	555			1.5	595			1	590	0.5	-	-	-	-	
	60	2469	545			2.0	585	3/4	16	1.0	-	-	-	-			
	65	2279	540	0.5	580	3.0	615	1.0	-	-	-	-	-				
	70	2116	535	1/2	101	0.5	580	3.0	615	1.0	-	-	-	-			
250	40	4630	750	2	108	2.5	775	2	108	2.0	-	-	-	-	-		
	45	4115	695	2.0	725	2.0	725			3.0	755	2	108	2.5	-	-	
	50	3704	660	1-1/2	105	3.0	690	1-1/2	105	2.0	720	1-1/2	105	1.0	-		
	55	3367	630	1	205	2.0	665	3/4	205	3.0	695	1	205	2.0	-	-	
	60	3086	605			2.0	645			1	680			0.5	680	1	205
	65	2849	590			2.5	630	2.0	665	2.0	665	1	205	1.0	-		
	70	2646	575	3.0	615	3/4	205	3.0	615	3/4	205	3.0	615	3/4	205	3.0	
300	40	5556	-	-	-	-	-	-	-	-	-	-	-	-	-		
	45	4938	865	3	111	2.0	890	3	111	1.5	915	3	111	1.0	-		
	50	4444	805	2	108	1.0	830	2	108	0.5	860			2.0	-		
	55	4040	760	1/2	106	2.5	785	1-1/2	106	1.5	815	2	108	1.0	-		
	60	3704	720			3.5	750			2.5	780	2.5	780	1-1/2	106	1.5	-
	65	3419	690			4.0	720	3.5	750	3.5	750	1-1/2	106	2.5	-		
	70	3175	660	1	205	1.0	695	1	205	0.5	725	1-1/2	106	3.0	-		
350	40	6481	1070	5	207	0.5	1095	3	111	0.0	-	-	-	-	-		
	45	5761	975			2.0	1000			1.5	1025	5	207	1.5	1025	5	207
	50	5185	905	3	111	1.0	930	3	111	0.5	955	3	111	0.0	-		
	55	4714	845			2.5	870			2.0	900			2.0	900	3	111
	60	4321	800	2	210	3.5	825	2	210	3.0	855	2	210	2.5	-		
	65	3989	760	0.0	790	1-1/2	105	1-1/2	105	4.0	815			3.0	-		
	70	3704	725	1.0	755	1-1/2	105	1-1/2	105	0.0	785	1-1/2	100	4.0	-		
400	40	-	-	-	-	-	-	-	-	-	-	-	-	-	-		
	45	6584	1010	5	207	1.5	1035	3	111	1.0	1055	5	207	0.5	-		
	50	5926	935			3.0	955			2.5	980			2.5	980	5	207
	55	5387	870	3	111	2.0	895	3	111	1.0	920	3	111	0.5	-		
	60	4938	820			3.0	850			2.5	875			2.5	875	3	111
	65	4558	780	2	210	4.0	805	2	210	3.5	835	2	210	2.5	-		
	70	4233	745	1-1/2	105	0.5	775	1-1/2	105	4.0	800			2	210	3.5	-

Filters

For blower units with enclosure and filter, add the following static pressures to the static pressure determined by the system designer for total external static pressure.

150	0.1" W.C.
175	0.2" W.C.
200	0.1" W.C.
250	0.2" W.C.
300	0.2" W.C.
350	0.2" W.C.
400	0.2" W.C.

Alternate Drives for 230/460V ③

Model	HP & Drive Listed	HP & Drive Needed ④
150	1 - 38	= 1 - 254
	1 - 192	= 1 - 256
175	1-1/2 - 193	= 1-1/2 - 198
	1-1/2 - 79	= 1-1/2 - 80
200	1 - 16	= 1 - 178
	1-1/2 - 105	= 1-1/2 - 180
250	1-1/2 - 23	= 1-1/2 - 177
	1 - 205	= 1 - 157
300	1-1/2 - 105	= 1-1/2 - 180
	1-1/2 - 23	= 1-1/2 - 177
350	1 - 205	= 1 - 157
	1-1/2 - 106	= 1-1/2 - 108
400	1-1/2 - 105	= 1-1/2 - 180

Alternate Drives for 575V ③

Model	Drive for Under 575V	Drive for 575V ④
150	1/4 - 191	= 1/4 - 197
	1/3 - 191	= 1/3 - 197
	1/3 - 95	= 1/3 - 96
175	1/3 - 95	= 1/3 - 96
	1-1/2 - 193	= 1-1/2 - 198
200	1/4 - 212	= 1/4 - 213
	1/3 - 212	= 1/3 - 213
	1/3 - 102	= 1/3 - 101
	1-1/2 - 105	= 1-1/2 - 180
250	1/3 - 203	= 1/3 - 204
	1-1/2 - 105	= 1-1/2 - 180
300	1-1/2 - 106	= 1-1/2 - 108
	1-1/2 - 105	= 1-1/2 - 180
350	1-1/2 - 105	= 1-1/2 - 180
	1-1/2 - 100	= 1-1/2 - 210
400	1-1/2 - 105	= 1-1/2 - 180

- ① Outputs shown are for elevations up to 2000'. For elevations over 2000', output needs to be reduced 4% for each 1000' above sea level. (Does not apply in Canada - see rating plate).
- ② Sheave turns open are approximate. For proper operation, check blower rpm.
- ③ Models not shown use same HP and drive numbers as cataloged.
- ④ Performance is the same; motor sheave accommodates larger shaft. When ordering 230/460V 1 & 1-1/2 HP or 575V, specify the listed drive from this table.

Table 12.1- Electrical/Control Code Selection Details - All Models

Model	Supply Voltage	Phase	Unit Voltage (Control & Mtr)	Accessory Transformer Required (Order Separate)	Control Codes Available	Factory Installed Transformer	Motor Starter Coil Voltage
HD/HDB	115	1 or 3	115V/1ph	none	11,12,21,22	115V to 24V	none
	208			208V to 115V			
	230			230V to 115V			
	460			460V to 115V			
	575			575V to 115V			
PDP/BDP	115	1 or 3	115V/1ph	none	30,59,63,85,87	115V to 24V	none
PDP	208			208V to 115V ②			
	230			230V to 115V ②			
	460			460V to 115V ②			
	575			575V to 115V ②			
PDP/BDP	208	1	208V/1ph	none	31,64,86,88	208V to 24V	none
	230		230V/1ph			230V to 24V	
BDP	208	3	208V/3ph	none	64,88	208V to 24V	208V
	230		230V/3ph			230V to 24V	230V
BDP	460	3	230V/3ph	460V to 230V ① ③	64,88	230V to 24V	230V
	575			575V to 230V ① ③			
BDP	460	3	460V/3ph	none	32,93	460V to 24V	24V
	575		575V/3ph			575V to 24V	

- ① Unit power code must match supply voltage, control voltage must match unit power.
- ② Certain 208V and 230V electrical distribution systems have connections available for supplying 115V service. This may eliminate the need for the additional field installed transformer. Please check with the job site electrician to determine applicability.
- ③ For CSA Canada certification, step down transformer may be required to be factory installed.

Table 12.2 - Gas Controls – All Models ①

Model	Model Size	Control System Description	Service Voltage	Gas Type	Control Code	Control Voltage			
HD/HDB	30-125	Single-Stage, Direct Spark Ignition Utilizes a single-stage combination gas control and an ignition control. Gas is automatically lit with the direct spark igniter on call for heat.	115V	Natural	11	24V			
				Propane	21				
	75-125	Two-Stage, Direct Spark Ignition Utilizes a two-stage combination gas control (fires at 50% or 100% of full rated input) and an ignition control. Gas is automatically lit with the direct spark igniter on call for heat.		Natural	12				
				Propane	22				
PDP/BDP	150-400	Single-Stage, Intermittent Pilot Ignition Utilizes a single-stage combination gas control and an ignition control. Pilot is automatically lit on call for heat.	115V	Natural	30	24V			
			208/230V		31				
			460V		32 ②				
			575V		33 ②				
			115V		85				
			208/230V		86				
		75-125	Two-Stage, Intermittent Pilot Ignition Utilizes a two-stage combination gas control (fires at 50% or 100% of full rated input) and an ignition control. Pilot is automatically lit only on call for heat.	115V	Propane		93 ②		
							575V	94 ②	
							115V	Natural	63
							208/230V	Natural	64
							115V	Propane	87
							208/230V	Propane	88

- ① All ignition controls are 100% Shut-Off with Continuous Retry.
- ② Available on BDP models only.

Table 13.1 - Field Installed Accessories

	Feature	Model			
		HD	HDB	PDP	BDP
Cabinet and Air Mover	Vertical Deflector Blades - Allows directional discharge air control in the left and right directions.	•	•	•	•
	Downward Air Deflector Hoods - Available in 30°, 60°, and 90° configurations these deflector hoods enable the unit to be mounted higher while still providing heat to the building occupants. Refer to page 14 for further details.	•	•	•	•
	Vibration Isolation Kit - Minimizes unit vibration transmission to the building structure.	•	•		
	Pipe Hanger Adapter Kits - Allows the unit to be suspended by 3/4" pipe from the standard 3/8" holes found in the top of the unit.			•	•
	Discharge Transition for Polytube - Allows for the connection of polytube (not included) to the discharge of the unit.		•		•
	Blower Enclosure with or without Filter Rack - Totally encases the motor and blower assembly. Optional filters provide filtering of the air prior to entering the heater.		•		•
	Discharge Velocity Generating Nozzle - Four varieties of velocity generating nozzles allow for increased application flexibility. These nozzles increase mounting height while also directing the airflow to the desired locations. Refer to page 15 for further details.				•
	Belt Guard - Provides protection for building occupants as well as service people from the drive belt and sheaves.				•
Controls	Natural Gas to Propane Gas Conversion Kit - Provides all required parts as well as instructions to convert a natural gas unit to propane gas.	•	•	•	•
	Single or Two-Stage Room Thermostats - See Table 13.2 for details.	•	•	•	•
	Room Thermostat Guard - Clear plastic for room thermostats. Guard is locking type and comes with two keys.	•	•	•	•
	Summer/Winter Switch - Allows a choice of unit fan operation. In the summer position, the fan runs continuously for ventilation while allowing the gas controls to fire on a call for heat from the thermostat. In the winter position, the fan runs intermittently on a call for heat from the thermostat.	•	•	•	•
	Stepdown Transformers - Used to operate propeller units on 208/230/460/575V/3Ph supply voltage. Also may be required for control circuits for blower units. Refer to Table 12.1 for further selection details.	•	•	•	•
	Control Relays - This single pole single throw relay consists of a 24V coil with a maximum contact rating of 18 amps at 115V.	•	•	•	•
	Gas Pressure Regulator - Fisher Type S-100, 3/4 inch pressure regulator for 5 to 50 psi inlet pressure capacity, 30 MBH to 400 MBH.	•	•	•	•
	Energy Saver Kit - Used to lower total energy costs by reducing stratified air in high mounting height applications. This kit consists of a controller with a SPDT (16A @ 120V) switch and a temperature range of 30° - 100°F.	•	•	•	•

Table 13.2 - Field Installed Thermostats

	Type	Description
Single-Stage Thermostats	Room Thermostat	White Rodgers 1C20-101: 50° - 90°F, 1.0A @ 24VAC
		White Rodgers 1C26-101: 50° - 90°F, 1.0A @ 24VAC, Heat/Off & Fan On/Auto Switches
Two-Stage Thermostats	Room - Digital	Honeywell TH5220D1003: 40° - 90°F, 1.0A @ 24VAC, System Heat/Cool/Auto/Off, Fan On/Auto
	Duct	Johnson Controls A350 Electronic Temp Control with Sensor and S350 Stage Adder (Blower units only)
		Honeywell T678A1015: 0° - 100°F, 20' capillary tube (Blower units only)

Table 14.1 - Downtown Hood General Performance Data for HD/PDP (feet)

Hood Type		Model HD Sizes				Model PDP Sizes						
		60	75	100	125	150	175	200	250	300	350	400
30°	Maximum Mtg Height	9	11	11	12	18	18	18	22	24	24	24
	X	4	5	5	6	6	9	6	8	8	8	8
	Y	11	14	14	16	20	26	18	24	26	24	24
	Z	16	21	20	23	29	37	26	35	38	36	35
60°	Maximum Mtg Height	9	11	11	12	18	18	18	22	24	24	24
	X	0	0	0	0	0	0	0	0	0	0	0
	Y	8	12	12	14	13	23	12	16	19	16	16
	Z	12	17	17	19	19	32	17	23	28	24	23
90°	Maximum Mtg Height	9	11	11	12	22	22	22	28	30	30	30
	S	10	14	13	15	23	25	22	29	32	20	29

Figure 14.1 - 30°, 60°, and 90° Downward Deflector Hoods

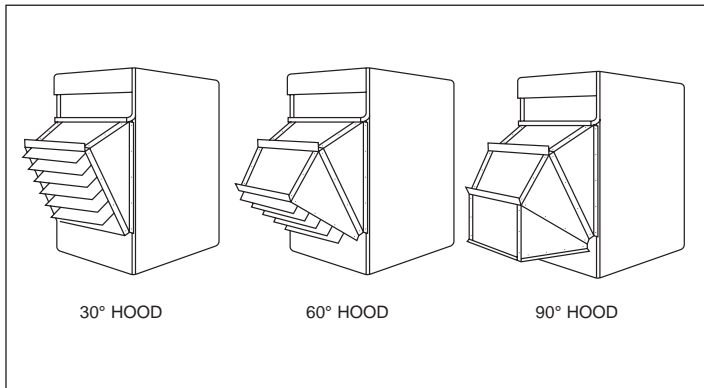

Figure 14.2 - 30° and 60° Throw/Floor Coverage

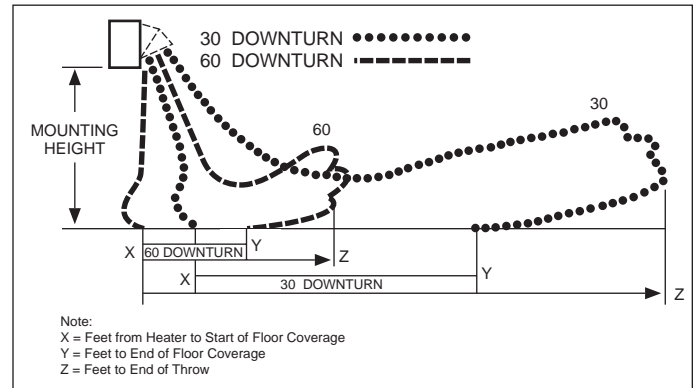

Figure 14.3 - 90° Hood Throw/Floor Coverage

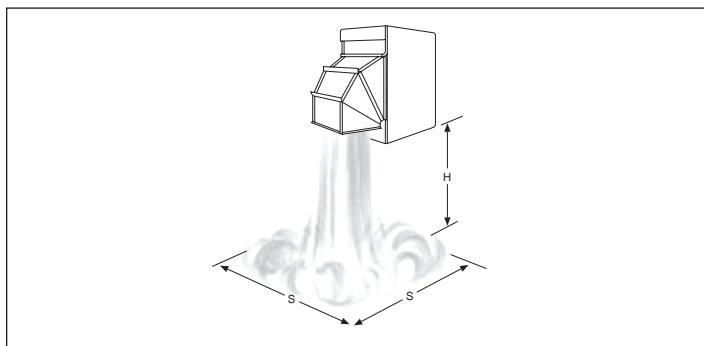
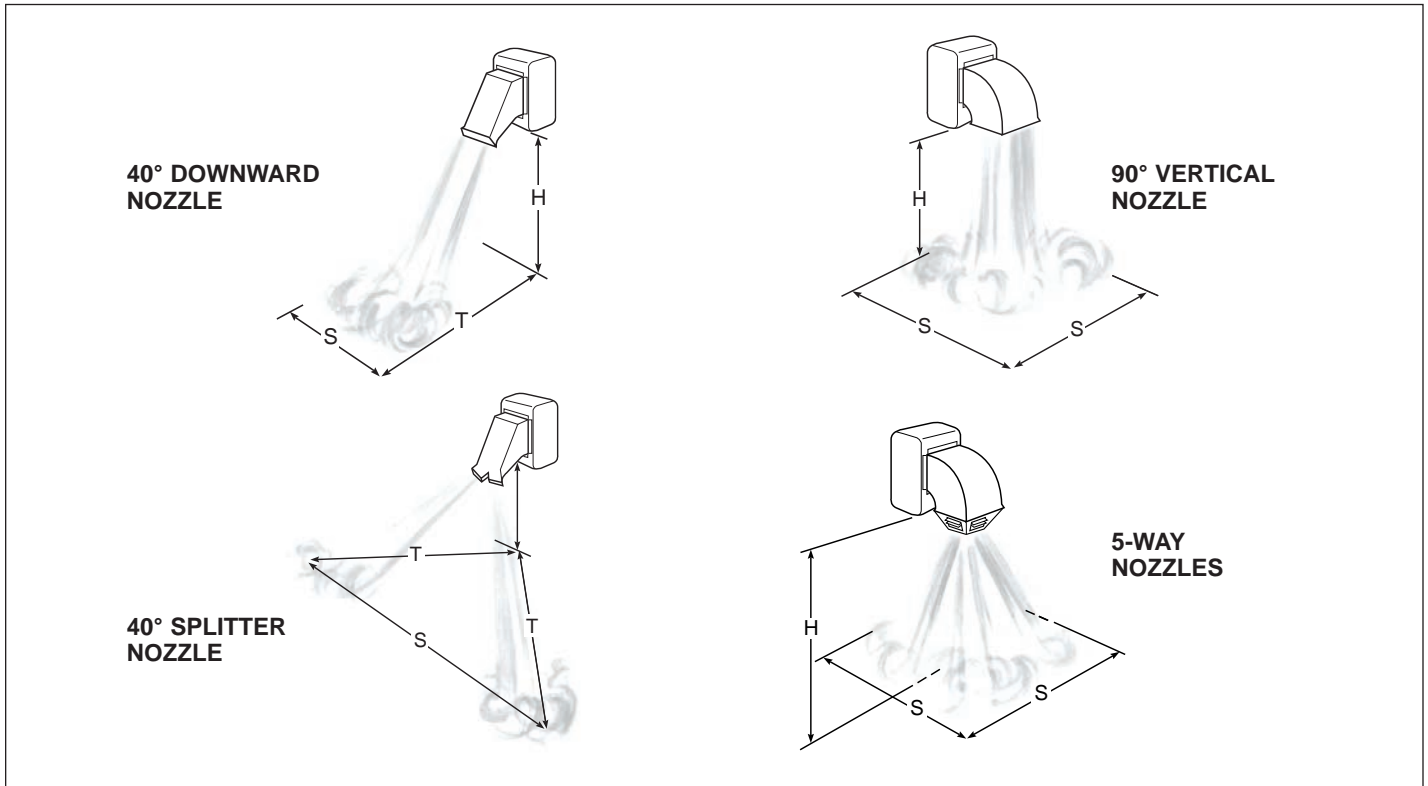

Figure 15.1 - Velocity Generating Nozzles ①



① Velocity generating nozzles available for Blower Model BDP only.

Table 15.1 - Blower Unit Model BDP Velocity Generating Nozzle Performance Data (feet) ②

Nozzle Type		BDP Blower Model Size						
		150	175	200	250	300	350	400
40° Downward Nozzle	Max. Mounting Ht. (ft.) H	26	25	27	29	31	32	32
	Heat Throw (ft.) T	79	76	81	86	94	96	96
	Heat Spread (ft.) S	26	25	27	29	31	32	32
90° Vertical Nozzle	Max. Mounting Ht. (ft.) H	26	26	24	29	31	32	32
	Heat Spread (ft.) S	26	26	24	29	31	32	32
40° Splitter Nozzle	Max. Mounting Ht. (ft.) H	24	24	23	25	28	30	32
	Heat Throw (ft.) T	60	59	59	62	70	75	80
	Heat Spread (ft.) S	120	118	117	124	140	151	160
5-Way Nozzle	Max. Mounting Ht. (ft.) H	22	21	20	25	26	23	26
	Heat Spread (ft.) S	31	29	28	35	36	32	36

② The above table is based on an inlet air temperature of 70°F and an air temperature rise of 55°F. Air deflectors on, 40° and 90° discharge nozzles set perpendicular to the face of the air discharge opening. On 5-way nozzles all air deflectors set perpendicular to floor. Static pressure measured at 0.1" W.C. for 90° nozzle, 0.2" W.C. for 40° downward and 5-way nozzle, and 0.3" W.C. for 40° splitter nozzle. Outlet velocities are approximately 1750 FPM for the 40° nozzles, 1000 FPM for the 90° nozzle and 1300 FPM for 5-way. For motor size, drive and blower rpm refer to pages 10 and 11. Mounting height measured from bottom of unit.

Selection Procedure

In order to properly select a unit heater it is necessary to have the following basic information.

1. Heating output capacity

Model size output is to be matched against the heat loss to be replaced.

2. External static pressure (blower units only)

The external static pressure (E.S.P.) is determined using the ASHRAE Guide for duct losses or provided by the design engineer.

3. Accessory internal static pressure (Nozzles, transitions, filters, etc.) (blower units only)

The critical accessories are those that add internal static pressure (I.S.P.) to the unit. Once these items are determined, the total pressure drop can be determined (if applicable).

4. Heat exchanger material

The heat exchanger type is determined by the application. The standard heat exchanger material is aluminized steel. A 409 stainless steel heat exchanger and burner is recommended when the combined entering/return air to the unit is below 40°F or in high humidity applications.

5. Type of fuel

Either natural or propane gas determined by the design engineer.

6. Gas controls

Either single stage, two stage, or mechanical modulation as determined by the design engineer.

7. Main power supply voltage to unit

8. Altitude at which unit is to be installed

With this information a basic unit can be selected as shown in the following example.

Selection Example Conditions (Propeller Unit)

In the following example, select a unit heater to meet the following conditions:

1. Heating output capacity = 156,000 Btu/Hr per design engineer
2. External Static Pressure = 0.0
3. Internal Static Pressure = 0.0. No static producing accessories are required
4. Heat exchanger and burner = 409 Stainless Steel
5. Gas Type = Natural
6. Gas Controls = Single Stage Intermittent Pilot Ignition (IPI)
7. Supply Voltage: 460V/60Hz/3Ph
8. Altitude: 1,000 feet

Selection Example Solution (Propeller Unit)

With the information listed above, the basic model, using the information in this catalog and the Model Nomenclature shown on page 23, can be selected as shown in the following example:

1. Determine the Model and Input Rating (MBH):

Using the Heating output capacity, the Furnace Input Rating is determined from Table 6.1. The closest model to 156,000 Btu/Hr output has an Btu/Hr Input rating of 200,000 Btu/Hr so the Furnace Input Rating = 200. The corresponding model for a 200 size, propeller, power vented unit heater is PDP. The model and size are a PDP200.

2. Determination of Heat Exchanger/Burner/Drip Pan Material:

From item #4 in the example, the Heat Exchanger and Burner required are 409 Stainless Steel. Thus, the Heat Exchanger Material = S from the Model Nomenclature on page 23. The burner is an option placed on the order.

3. Determine the development sequence:

From item #6 in the example, the IPI results in the Development Sequence = E from the Model Nomenclature on page 23.

4. Determine Power Code Required:

Referring to Table 6.2, it can be seen that the supply voltage from the example conditions is not available (460V). A transformer kit selected later in this example must be used. In this instance, from Table 6.2 select the 115V/60Hz/1Ph power code (PC) = 01 unit.

5. Determine the control type:

From items #5 and #6 in the example conditions, the gas type is Natural Gas and controls are single stage IPI. Given the supply voltage listed from the example conditions (460V) and by looking up the supply voltage of 460V/60Hz/3Ph in Table 12.2 for propeller units, it directs us use to a unit voltage of 115V. We then refer to Tables 12.1 and 12.2, locate the single-stage options and select the appropriate Control Code (CC) of 30. Remember a step-down transformer will be selected later in this example.

At this point we have a full model number of: PDP200SE0130

6. Determination of transformer:

To operate a 115V/60Hz/1Ph unit on 460V/60Hz/3Ph supply power a unit step down transformer must be selected. By referring to Table 12.1 we see that a 460V to 115V step down transformer is required.

7. Altitude:

Since deration of gas fired unit heaters is only required for units to be installed at 2,000 ft or greater, no high altitude kit is required.

Selection Example Conditions (Blower Unit)

In the following example, select a unit heater to meet the following conditions:

1. Heating output capacity = 156,000 Btu/Hr per design engineer
2. External Static Pressure = 0.2.
3. Internal Static Pressure = 0.0. No static producing accessories are required
4. Heat exchanger and burner = Aluminized Steel
5. Gas Type = Propane
6. Gas Controls = Two stage Intermittent Pilot
7. Supply Voltage: 230V/60Hz/3Ph
8. Altitude: 1,000 feet
9. CFM = 2,400

Selection Example Solution (Blower Unit)

With the information listed above, the basic model, using the information in this catalog and the Model Nomenclature shown on page 23, can be selected as shown in the following example:

1. Determine the Model and Input Rating (MBH):

Using the Heating output capacity, the Furnace Input Rating is determined from Table 7.1. The closest model to 156,000 Btu/Hr output has an Btu/Hr Input rating of 200,000 Btu/Hr so the Furnace Input Rating = 200. The corresponding model for a 200 size, blower, power vented unit heater is BDP. The model and size are a BDP200.

2. Determination of Heat Exchanger/Burner/Drip Pan Material:

From item #4 in the example, the Heat Exchanger and Burner required are aluminized steel. Thus, the Heat Exchanger Material = A from the Model Nomenclature on page 23.

3. Determine the development sequence:

From item #6 in the example, the IPI results in the Development Sequence = E from the Model Nomenclature on page 23.

4. Determine Power Code Required:

From page 10 we see that a unit requiring a static of 0.2 and a cfm of 2400 requires a 1/3 horsepower motor with a -102 drive that is turned open 4.0 turns. Referring to Table 9.1 it can be determined that for a BDP200 with a 1/3 HP motor and a -102 drive operating on 230V/60Hz/3Ph that it will have a power code = 21.

5. Determine the control type:

From item #5 in the example, the gas type is Propane Gas and controls are Two Stage. Given the supply voltage listed in #7, we can refer to Tables 12.1 and 12.2 to determine what controls are needed. This results in a Control Code (CC) = 88.

At this point we have a full model number of: BDP200AE2188

6. Altitude:

Since deration of gas fired unit heaters is only required for units to be installed at 2,000 ft or greater, no high altitude kit is required.

Propeller Units - Model HD

Figure 18.1 - Dimensional Drawings - Model HD

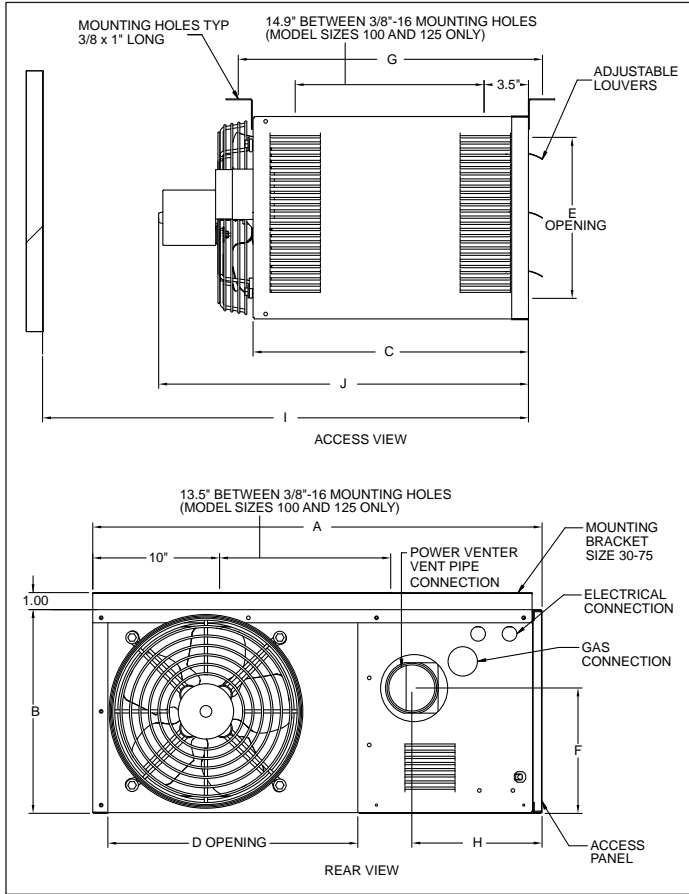

Blower Units - Model HDB

Figure 18.2 - Dimensional Drawings - Model HDB

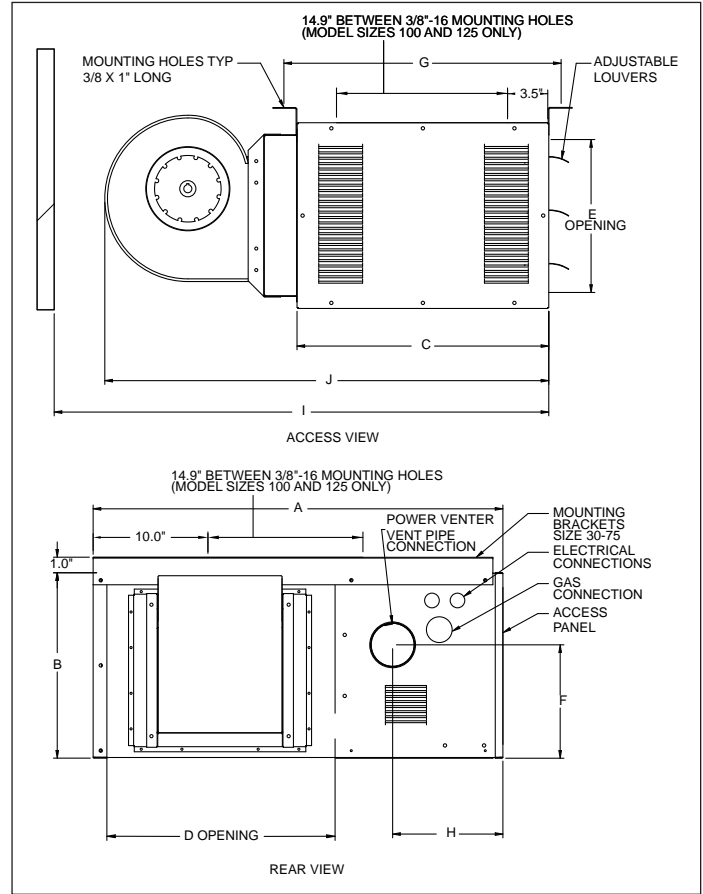

Table 18.1 - Dimensions (inches) - HD

Models	HD30	HD45	HD60	HD75	HD100/125
A	26.8	26.8	26.8	26.8	35.5
B	12.2	12.2	18.0	18.0	20.5
C	16.5	16.5	16.5	16.5	22.0
D	14.9	14.9	14.9	14.9	22.5
E	10.1	10.1	15.9	15.9	18.4
F	7.5	7.5	10.7	10.7	14.0
G	18.5	18.5	18.5	18.5	-
H	7.6	7.6	7.8	7.8	8.4
Gas Connection	1/2	1/2	1/2	1/2	1/2
I	34.5	34.5	34.5	34.5	43.0
J	22	22	25	25	31.0
Fan Diameter	10	10	14	14	18.0
Approx. Shipping Weight (lbs.)	55	60	80	85	125
Vent Pipe Connector Diameter (in)	3	3	3	3	4

Table 18.2 - Dimensions (inches) - HDB

Models	HDB 60	HDB 75	HDB100/125
A	26.8	26.8	35.5
B	18.0	18.0	20.5
C	16.5	16.5	22.0
D	14.9	14.9	22.5
E	15.9	15.9	18.4
F	10.7	10.7	14.0
G	18.5	18.5	-
H	7.8	7.8	8.4
Gas Connection	1/2	1/2	1/2
I	34.5	34.5	44.5
J	25.0	25.0	41.5
Blower	9 - 7	9 - 7	10 - 10
Approx. Shipping Weight (lbs.)	92	97	151
Vent Pipe Connector Diameter (in)	3	3	4

Table 18.3 - Clearance to Combustibles, Model HD/HDB

Unit Side	Clearance To Combustible Materials	Recommended Service Clearance
Top and Bottom	1"	1"
Access Side	1"	18"
Non-Access Side	1"	1"
Rear	18"	18"
Vent Connector	4"	4"

Propeller Units - Model PDP

Figure 19.1 - Dimensional Drawings

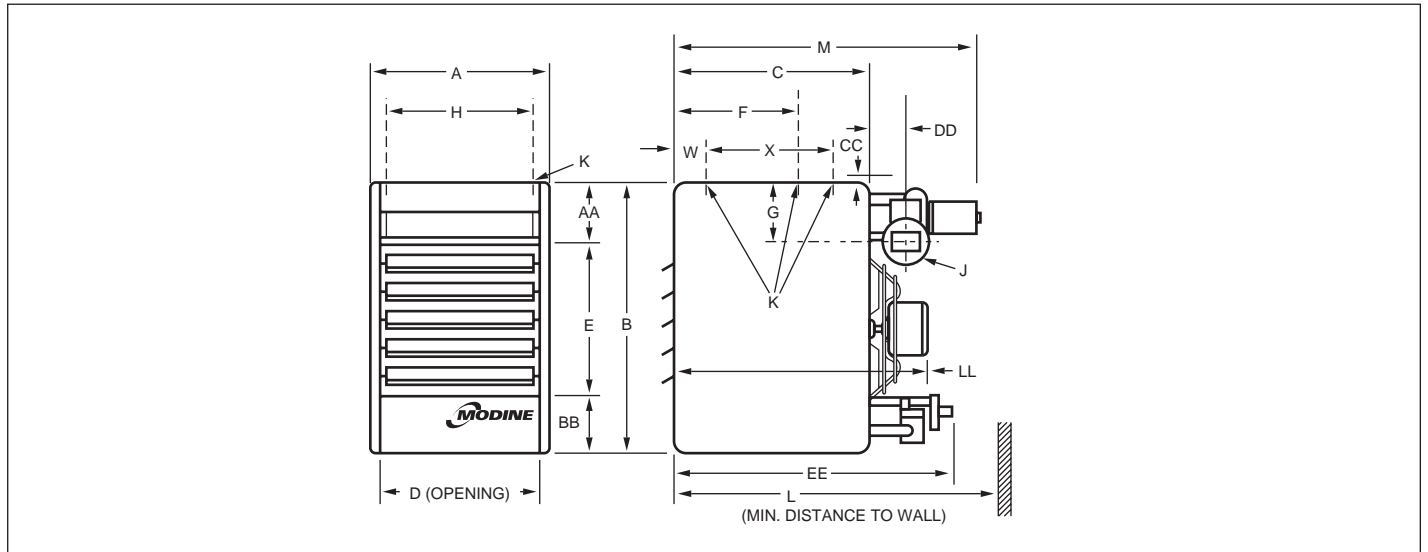

Table 19.1 - Dimensions (inches) - PDP ①

Dimension Symbol	Model Number						
	PDP 150	PDP 175	PDP 200	PDP 250	PDP 300	PDP 350	PDP 400
A	21	23-1/2	25-5/8	25-5/8	28-5/8	33-5/8	40
B	35-1/4	35-1/4	40-1/4	40-1/4	40-1/4	40-1/4	40-1/4
C	22	22	25	25	25	25	25
D	18-9/16	21-1/16	23-3/16	23-3/16	26-3/16	31-3/16	37-1/2
E	20	20	24	24	24	24	24
F	12	12	13-1/2	13-1/2	14	—	—
G	6-9/16	6-9/16	7-1/2	7-1/2	7-1/2	7-1/2	7-1/2
H	17-3/8	19-7/8	22	22	25	30	36-3/8
J ②	5	5	5	6	6	6	6
K (Mounting Holes) ③	3/8-16	3/8-16	3/8-16	3/8-16	3/8-16	3/8-16	3/8-16
L ④	35-13/16	35-9/16	40-3/4	40-3/4	40-3/4	40-3/4	44-3/16
M	29-13/16	29-9/16	34-3/4	34-3/4	34-3/4	34-11/16	38-3/16
W	—	—	—	—	—	5	5
X	—	—	—	—	—	16	16
AA	8	8	9	9	9	9	9
BB	7-1/4	7-1/4	7-1/4	7-1/4	7-1/4	7-1/4	7-1/4
CC	—	—	—	—	—	—	—
DD	2-3/4	2-3/4	3-3/8	3-3/8	3-3/8	3-3/8	6-13/16
EE	30-1/2	30-1/2	32-7/8	32-7/8	32-7/8	32-7/8	32-7/8
LL	31-1/8	31-1/8	34-7/8	34-7/8	36-1/4	35-1/2	40-1/2
Gas Connections ⑤	1/2	1/2	1/2	1/2	1/2	3/4	3/4
Fan Diameter	16	18	20	20	22	22	24
Approx. Weight	168	175	239	239	269	338	418

Figure 19.2 - Combustible Material and Service Clearances

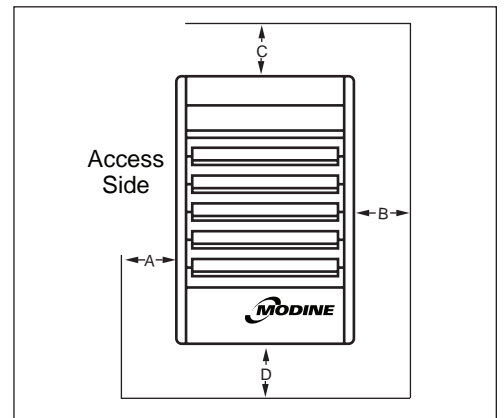

Table 19.2 - Combustible Material Clearances ①

Model Size	Access Side (A)	Non-Access Side (B)	Top (C)	Bottom (D)	Top of Power Exhauster (Not shown)
150-175	1	1	4	12	2
200-400	1	1	5	12	3

① Provide sufficient room around the heater to allow for proper combustion and operation of fan. Free area around the heater must not be less than 1-1/2 times the discharge area of the unit.

- ① Do not use propeller units with duct work.
- ② For some models, this is the dimension of the vent transition outlet supplied.
- ③ PDP 150 through PDP 300 — 2 holes (and the level hanging adjustment feature). PDP 350 through PDP 400 — 4 holes. (Listed is the hole diameter and threads per inch to accept threaded rod).
- ④ Dimension equals overall plus 6".
- ⑤ For natural gas; may vary depending on control availability.

Blower Units - Model BDP

Figure 20.1 - Dimensional Drawings

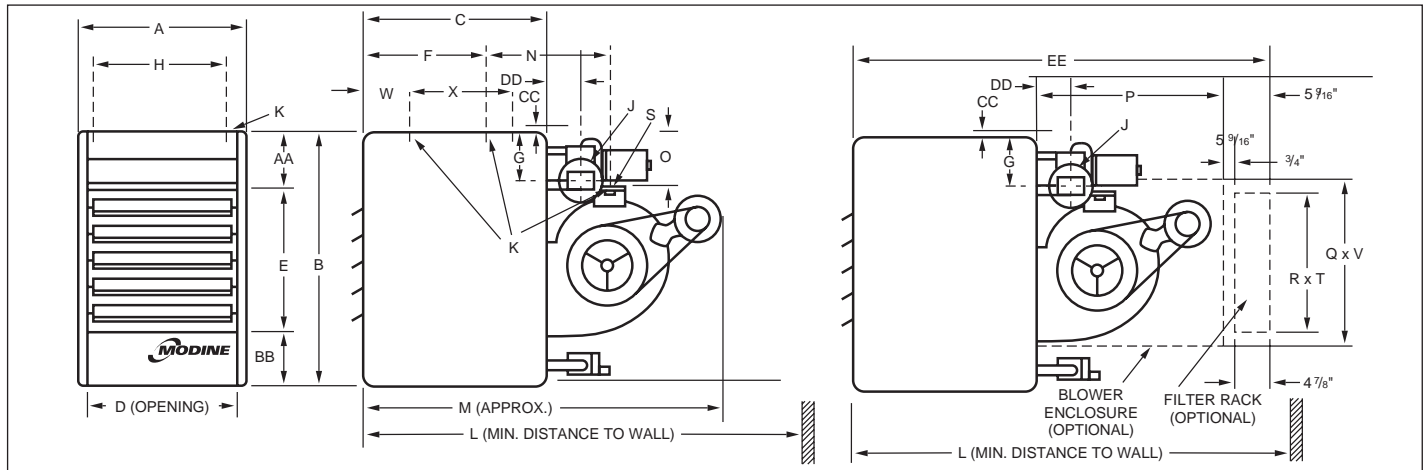

Table 20.1 - Dimensions (inches) — BDP

Dimension Symbol	Model Number						
	BDP 150	BDP 175	BDP 200	BDP 250	BDP 300	BDP 350	BDP 400
A	21	23-1/2	25-5/8	25-5/8	28-5/8	33-5/8	40
B	35-1/4	35-1/4	40-1/4	40-1/4	40-1/4	40-1/4	40-1/4
C	22	22	25	25	25	25	25
D	18-9/16	21-1/16	23-3/16	23-3/16	26-3/16	31-3/16	37-1/2
E	20	20	24	24	24	24	24
F	12	12	13-1/2	13-1/2	14	—	—
G	6-9/16	6-9/16	7-1/2	7-1/2	7-1/2	7-1/2	7-1/2
H	17-3/8	19-7/8	22	22	25	30	36-3/8
J ^①	5	5	5	6	6	6	6
K Mounting Holes ^②	3/8-16	3/8-16	3/8-16	3/8-16	3/8-16	3/8-16	3/8-16
L w/ Blwr Encl & Filt Rk	62-5/8	62-5/8	69-5/8	69-5/8	69-5/8	69-5/8	69-5/8
L w/o Blwr Encl & Filt Rk	53-1/8	53-1/8	61	61	61	61	65
M ^③	47-1/8	47-1/8	55	55	55	55	59
N ^④	21-1/2	21-1/2	25-7/16	25-7/16	24-15/16	17-15/16	22
O	7-1/4	7-1/4	8-1/2	8-1/2	8-1/2	8-1/2	8-1/2
P	30	30	34	34	34	34	34
Q Blower Encl Ht	21-3/8	21-3/8	25-1/8	25-1/8	25-1/8	25-1/8	25-1/8
R Inlet Duct Height	20	20	23-3/4	23-3/4	23-3/4	23-3/4	23-3/4
S Center to Center Blower Mtg. Holes	17-5/16	17-3/8	20-3/8	20-3/8	20-3/8	20-3/8	20-3/8
T Inlet Duct Width	27-1/2	27-1/2	32-3/4	32-3/4	32-3/4	42-7/8	42-7/8
V Blower Encl Width	29	29	34-1/4	34-1/4	34-1/4	44-3/8	44-3/8
W	—	—	—	—	—	5	5
X	—	—	—	—	—	16	16
AA	8	8	9	9	9	9	9
BB	7-1/4	7-1/4	7-1/4	7-1/4	7-1/4	7-1/4	7-1/4
CC	—	—	—	—	—	—	—
DD	2-3/4	2-3/4	2-3/4	3-3/8	3-3/8	3-3/8	6-13/16
EE	56-5/8	56-5/8	63-5/8	63-5/8	63-5/8	63-5/8	63-5/8
Gas Connections ^⑤	1/2	1/2	1/2	1/2	1/2	3/4	3/4
Std. Mtr. Sheave Dia.	3	3	3	3	3	3	4-1/2
Std. Blower Sheave Dia.	11	7	14	10	7	6	10
Blower Wheel Diameter	13	13	15	15	15	15	15
Approx. Weight	152	152	315	315	339	428	498

Figure 20.2 - Combustible Material and Service Clearances

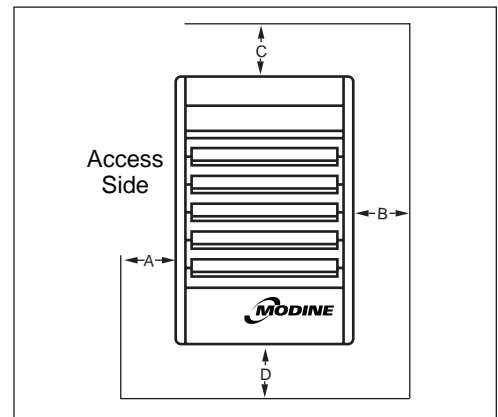

Table 20.2 - Combustible Material Clearances^①

Model Size	Access Side (A)	Non-Access Side (B)	Top (C)	Bottom (D)	Top of Power Exhauster (Not shown)
150-175	1	1	4	12	2
200-400	1	1	5	12	3

^① Provide sufficient room around the heater to allow for proper combustion and operation of fan. Free area around the heater must not be less than 1-1/2 times the discharge area of the unit.

- ^① For some models, this is the dimension of the vent transition outlet supplied.
- ^② BDP 150 thru BDP 300 — 4 holes (2 on blower and 2 on unit). BDP 350 and BDP 400 — 6 holes (2 on blower and 4 on unit). (Listed is the hole diameter and threads per inch to accept threaded rod).
- ^③ This is an approximate dimension for standard motors, allow 3" for sheave and optional motors.
- ^④ Distance between mounting hole in unit casing and mounting hole on blower. On the BDP 350 and BDP 400, the distance is from rear mounting hole in casing to the mounting hole on blower.
- ^⑤ For natural gas; may vary depending on control availability.

General

A. Standards

All unit(s) shall include:

- A.1. C.S.A. (Canadian Standards Association) design certification for use in both the US and Canada to the ANSI Z83.8 - latest revision, standard for "Gas Unit Heater and Gas-Fired Duct Furnaces" for safe operation, construction, and performance.

B. Mechanical Configuration

- B.1. Furnace(s) section with 80% minimum efficiency provided by an indirect-fired heat exchanger with dimpled tube pattern for efficient heat transfer. (PDP/BDP models)
- B.2. Furnace(s) section with 80% minimum efficiency provided by an indirect-fired tubular heat exchanger with individually fired tubes for maximum heat transfer with minimal noise of flame ignition/extinction. (HD/HDB models)

C. Venting Arrangement

- C.2. The venting shall be a power exhausted arrangement. The unit shall be tested to insure proper ignition when the unit is subjected to 40 mile per hour wind velocities. The unit shall also include a factory mounted differential pressure switch designed to prevent main burner ignition until positive venting has been proven.

D. Unit Casing

- D.1. The unit heater(s) casing shall be constructed of not less than 20 gauge aluminized steel with minimization of exposed fasteners. (PDP/BDP models)
- D.1.a. The unit heater(s) casing shall be constructed of not less than 22 gauge aluminized steel with minimization of exposed fasteners. (HD/HDB models)
- D.2. All exterior casing parts shall be cleaned of all oils and a phosphate coating applied prior to painting. The exterior casing parts shall then be painted with an electrostatically applied baked-on gray-green polyester powder paint (7-mil thickness) for corrosion resistance.
- D.3. The unit shall be furnished with horizontal air deflectors. The deflectors are adjustable to provide for horizontal directional airflow control (up or down).

E. Furnace Section

- E.1. The heat exchanger(s) shall be made of 20 gauge aluminized steel tubes and headers (opt 409 stainless steel). (PDP/BDP models)
The thermal efficiency of the unit(s) shall be a minimum of 80% efficient for all air flow ranges.
Each heat exchanger tube shall be individually and directly flame-fired. The heat exchanger tube shall be contoured and dimpled to provide efficient heat transfer and crimped to allow for thermal expansion and contraction. The flue collector box shall be made of 20 gauge aluminized steel.
- E.1.a. The heat exchanger(s) shall be made of 18 gauge aluminized steel (opt 409 stainless steel). (HD/HDB models)
The thermal efficiency of the unit(s) shall be a minimum of 80% for all air flow ranges.
Each heat exchanger tube shall be individually and directly flame-fired. Each heat exchanger tube shall be individually and directly flame-fired. The heat exchanger tube shall be contoured and dimpled to provide efficient heat transfer and crimped to allow for thermal expansion and contraction. The flue collector box shall be made of 20 gauge aluminized steel.
- E.2. The heat exchanger(s) seams and duct connections shall be certified to withstand 0.9" W.C. external static pressure without burner flame disturbance. (HD/HDB models)

- E.2.a. The heat exchanger(s) seams and duct connections shall be certified to withstand 0.5" W.C. external static pressure without burner flame disturbance. (PDP/BDP models)
- E.3. The burner(s) shall be made of the same material as the heat exchanger with a thickness of not less than 28 gauge. Burner(s) shall have non-clogging, slotted ports with a stainless steel separator strip designed for good lighting characteristics without noise of extinction for both natural and propane gas. (PDP/BDP models)
- E.3.a. The burner(s) shall be in-shot type, directly firing each heat exchanger individually and is (are) designed for good lighting characteristics without noise of extinction for both natural and propane gas. (HD/HDB models)
- E.4. The orifices shall be provided on propane gas with adjustable air shutters for controlling the primary air mixture. (PDP/BDP models)
- E.5. The ignition controller(s) shall be 100% shut-off with continuous retry.
- E.6. The gas pressure shall be between 6-7" W.C for natural gas. (opt) The gas pressure shall be 11-14" W.C. for propane gas.
- E.7. The solid state ignition system shall intermittently light the pilot each time the system is energized. Once the pilot is proven, the main gas valve shall open and allow gas flow to the main burner. (PDP/BDP models)
- E.7.a. The solid state ignition system shall directly light the gas by means of a direct spark igniter each time the system is energized.
- E.8. The unit gas controls shall be provided with the following:
- E.8.d. (opt) Single-stage gas controls with a single-stage combination gas control, an ignition control, and a single-stage low voltage thermostat. The unit fires at 100% full fire based on a call for heat from a room thermostat.
- E.8.e. (opt) Two-stage gas controls with a two-stage combination gas control, an ignition control, and a two-stage low voltage thermostat. The unit fires at 50% fire on low stage or 100% fire on high stage of the unit based on the call for heat from either a room or duct thermostat.
- E.9. An automatic reset high limit switch mounted in the air stream to shut off the gas supply in the event of overheating.
- E.10. A time delay relay that delays the start of the air mover to allow the heat exchanger a warm-up period after a call for heat. The time delay relay shall also continue the air mover operation after the thermostat has been satisfied to remove any residual heat in the heat exchanger. (Note: Mechanical modulation units not supplied with a time delay relay)
- E.11. The unit shall be orificed for up to 2000' elevation above sea level. (opt) The unit shall be orificed for _____ elevation above sea level.

F. Electrical

- F.1. All electrical components shall carry UL, ETL, or CSA listing.
- F.2. A low voltage terminal board shall be provided for direct wiring connection to an external thermostat.
- F.3. A single step down transformer shall be provided for all unit controls.

G. Air Mover

- G.1. The motor horsepower shall be ____.
- G.2. The motor wiring shall be in flexible metal BX conduit.
- G.3. (opt) The motor shall be controlled by a time delay relay (opt) and motor starter.
- G.4. Propeller models shall meet the following requirements.
 - G.4.a. The motor type shall be Single-speed, Totally Enclosed (TE) (Open Drip Proof (ODP) on HD units 75MBH and smaller)
 - G.4.b. The motor shall be rated for:
 - (a) 115V/60Hz/1Ph
 - (b) 208V/60Hz/1Ph (PDP model)
 - (c) 230V/60Hz/1Ph (PDP model)
- G.5. Blower models shall meet the following requirements.
 - G.5.a. The motor type shall be Single-speed, totally enclosed (TE) (Open Drip Proof (ODP) on all HDB units)
 - G.5.b. The motor shall be rated for:
 - (a) 115V/60Hz/1Ph
 - (b) 208V/60Hz/1Ph (BDP model)
 - (c) 230V/60Hz/1Ph (BDP model)
 - (d) 208V/60Hz/3Ph (BDP model)
 - (e) 230V/60Hz/3Ph (BDP model)
 - (f) 460V/60Hz/3Ph (BDP model)
 - (g) 575V/60Hz/3Ph (BDP model)
 - G.5.c. The motor shall be provided with an adjustable motor sheave to allow for minor adjustment of the blower rpm at the job site. (BDP model)
 - G.5.d. The blower shall be a double width, double inlet (DWDI), forward curved, belt driven, assembly with spider ball bearings.
 - G.5.e. The motor shall be provided with three speed taps to allow for adjustment of the blower rpm at the job site. (HDB model)
 - G.5.f. The blower shall be a double width, double inlet (DWDI), forward curved, direct motor drive assembly with spider ball bearings. (HDB model)

H. Mounting

- H.1. The unit shall be equipped with tapped holes to accept 3/8-16 threaded rod for suspension. (HD/HDB size 100/125 and PDP/BDP models)
- H.1.a. The unit shall be equipped with mounting brackets to allow for threaded rod suspension or to be bolted directly to the ceiling support structure allowing 1" of top clearance. (HD/HDB models - opt on sizes 100/125)
- H.2. Propeller Unit (Sizes 150 – 300) to have two point adjustable suspension points to allow for level hanging with a variety of accessories.
- H.3. Propeller unit (Sizes 30-75 and 350-400) and blower units (Sizes 60-300) to have 4 suspension points.
- H.4. Blower unit (Sizes 350, 400) to have 6 suspension points.

J. Accessories

The following field installed accessory control devices shall be provided with the unit:

- J.1. A 5-50 psi gas pressure regulator to reduce the inlet gas pressure for the operating controls.
- J.2. A clear plastic thermostat guard with two keys for room thermostats.
- J.3. A SPST summer winter switch for continuous fan in the summer position and intermittent fan and burner in the winter position.
- J.4. Pipe Hanger Adapter Kit to facilitate threaded pipe suspension. (HD/HDB size 100/125 and PDP/BDP models)

- J.5. An Energy Saver Kit used to reduce stratified air in high mounting height applications. (PDP/BDP models)
- J.7. Vertical Deflector Kit to enable side distribution of airflow.
- J.8. A blower enclosure fully encloses blower to enable the attachment of filter racks and/or duct.
- J.9. A combination filter rack/duct connector containing a 1" thick, cleanable filter.
- J.11. A belt guard enclosing the belts and sheaves (pulleys) on a blower type unit heater. (BDP model)
- J.12. Propane conversion kit for converting natural gas units to propane gas.
- J.13. 40° downward double deflection velocity generating discharge nozzle. (BDP model)
- J.14. 40° splitter double deflection velocity generating discharge nozzle. (BDP model)
- J.15. 90° vertical double deflection velocity generating discharge nozzle. (BDP model)
- J.16. 5-way downward velocity generating discharge nozzle. (BDP model)
- J.17. Discharge Transition from unit to polytube. (HDB/BDP models)
- J.18. 30° non-velocity generating downward air deflector hood constructed of 20 ga. cold rolled steel with baked-on gray-green polyester powder paint.
- J.19. 60° non-velocity generating downward air deflector hood constructed of 20 ga. cold rolled steel with baked-on gray-green polyester powder paint.
- J.20. 90° non-velocity generating downward air deflector hood constructed of 20 ga. cold rolled steel with baked-on gray-green polyester powder paint.
- J.21. (opt) A 208V to 115V step down shall be provided for operation of the propeller unit.
- J.22. (opt) A 230V to 115V step down shall be provided for operation of the propeller unit.
- J.23. (opt) A 460V to 115V step down shall be provided for operation of the propeller unit.
- J.24. (opt) A 575V to 115V step down shall be provided for operation of the propeller unit.

K. Thermostats

The unit shall be provided with the following thermostat:

- K.2. A single stage room thermostat with a 50°-90°F range.
- K.3. A single stage room thermostat with a 50°-90°F temperature set point range. The stat shall also include switching for Heat/Off and Fan On/Auto control.
- K.4. Honeywell TH5220D1029 digital non-programmable configurable room thermostat with switching.
- K.5. A field installed two-stage duct thermostat with a 0°-100°F range and 20-foot capillary.
- K.6. A two-stage electronic duct thermostat with field installed temperature sensor, temperature selector and one stage adder.

Figure 23.1 - Model Number Designations

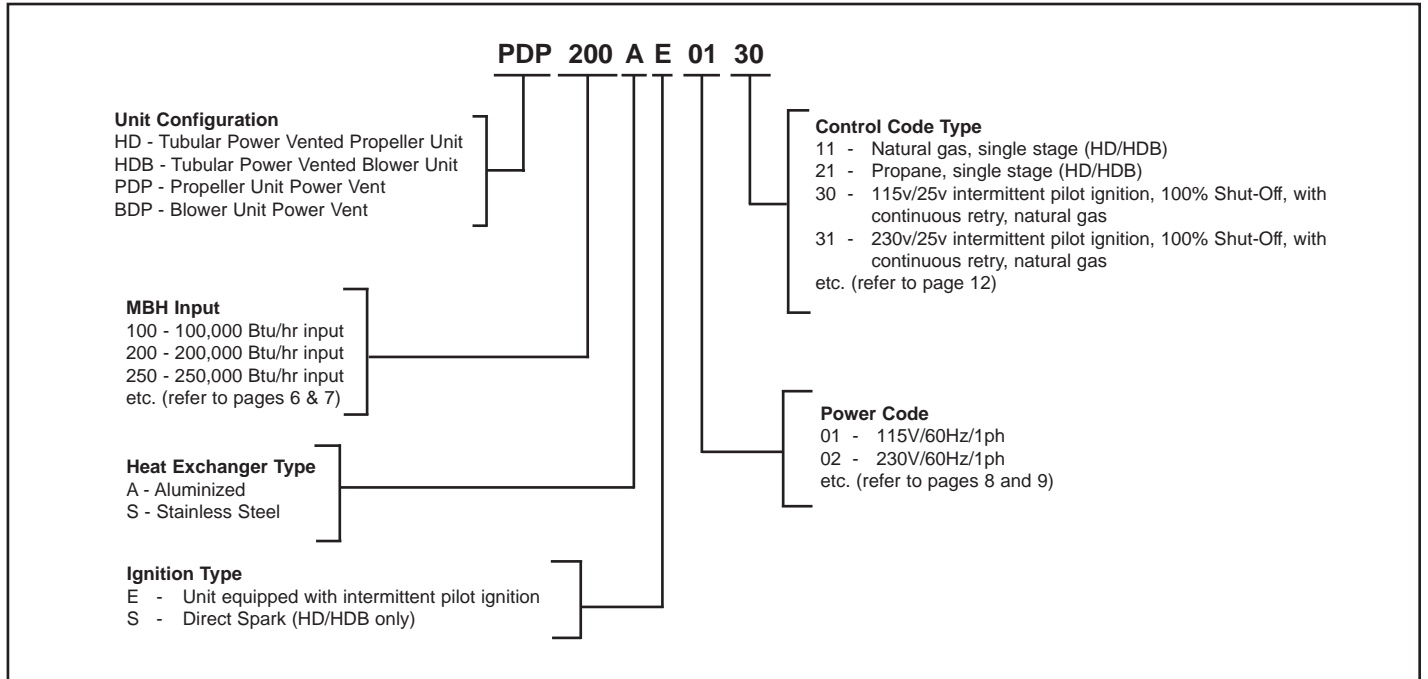

INDOOR AIR SOLUTIONS

The Modine brand has been the industry standard since Arthur B. Modine invented and patented the first lightweight, suspended hydronic unit heater in 1923.

No other manufacturer can provide the combined application flexibility, technical expertise and fast delivery found at Modine.

Consult your local Modine distributor for help in solving your indoor air problems.

Products from Modine are designed to provide indoor air-comfort solutions for commercial, institutional and industrial applications. Whatever your heating, ventilating and cooling requirements, Modine has the product to satisfy your needs, including:

- Gas-fired unit heaters
- Gas-fired duct furnaces
- Gas-fired high-intensity infrared heaters
- Gas-fired low-intensity infrared heaters
- Steam/hot water unit heaters
- Steam/hot water cabinet unit heaters
- Steam/hot water commercial fin tube radiation
- Oil-fired unit heaters
- Electric unit heaters
- Indoor gravity and power vented single and multiple duct furnace make-up air units
- Indoor separated combustion single and multiple duct furnace make-up air units
- Outdoor single and multiple duct furnace make-up air units
- Direct-fired make-up air units
- R410 DX split system air conditioning and heat pump ceiling cassettes
- Chilled water ceiling cassettes

With burner capacities up to 7,862,000 Btu/hr and air-handling capacities as high as 60,000 CFM, Modine products are compatible with every fuel type, including:

- **Natural or Propane Gas** • **Steam/Hot Water** • **Oil** • **Electric**

Specific catalogs and computer-generated heat-loss calculations are available for each product. Catalogs 75-136 and 75-137 provide details on all Modine HVAC equipment.

Distributed By:



Commercial Products Group
Modine Manufacturing Company

1500 DeKoven Avenue
Racine, Wisconsin 53403-2552

Phone: 1.800.828.4328 (HEAT)

Fax: 1.800.204.6011

www.modinehvac.com

© Modine Manufacturing Company 2011
Litho in USA