



INSTRUCTION SHEET

Bulletin No. 1531039

O12/O22 Dual PRESSURE CONTROL

DESCRIPTION/APPLICATION

Ranco dual pressure controls are used for either operating or protecting commercial refrigeration and air conditioning systems. Within one NEMA 1 enclosure, they are a combination of both high and low pressure controls interconnected to operate a common switch.

Ranco dual pressure controls are suitable for R12, R22, and R502 refrigerants and are available with either male flare or capillary with flare nut pressure connections.

The O12, with a single pole, single throw switch (SPST), will directly control a single phase compressor; the O12 may also be used with a contactor for pilot control of single and three-phase compressors. The O22, with a double pole, single throw switch (DPST), will directly control single or three-phase compressors. The electrical ratings inside the control cover must not be exceeded.

The low pressure closes (cuts-in) the switch on rise of compressor suction pressure and opens (cuts-out) the switch on pressure drop. The high pressure function overrides to open the switch as the compressor discharge pressure rises. See page 3 for Control Adjustments.

Three versions of switch operation are available: automatic on both low and high pressure; manual reset on both low and high pressure; and convertible (manual or automatic) on high pressure with automatic on low pressure. The convertible reset feature allows the high pressure side to be changed from manual to automatic reset by merely turning the selector screw.

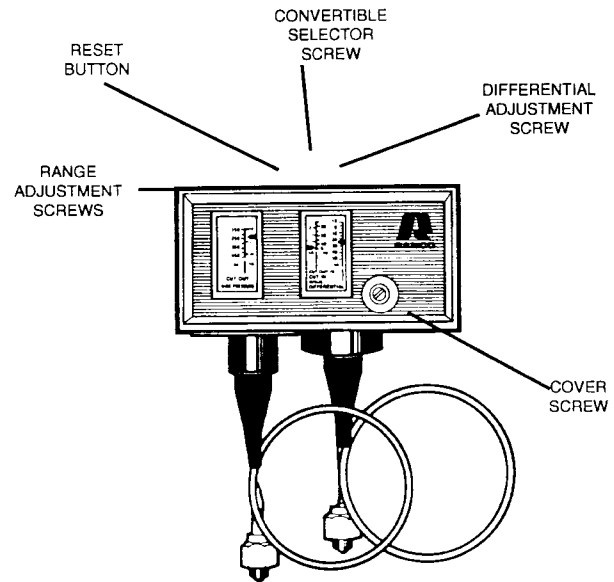

INSTALLATION

CAUTION

To prevent possible electrical shock or equipment damage, disconnect electrical power to unit before and during installation. **DO NOT** restore electrical power to unit until the control is properly installed and grounded. **DO NOT** locate the control in an explosive atmosphere as a safety hazard can result due to possible spark generation in the control.

Controls are not to be located in areas of extreme moisture, dirt or dust, or in a corrosive or explosive atmosphere. These environments can shorten control life.

IMPORTANT NOTICE

MANUAL OPERATION (tripping switch)

The switch can be manually closed by lifting the bellows tab on the low pressure side, provided that the system high pressure is below the high pressure cut-in. Cycling the control at any other point **WILL CAUSE CONTROL DAMAGE AND VOIDS WARRANTY.**

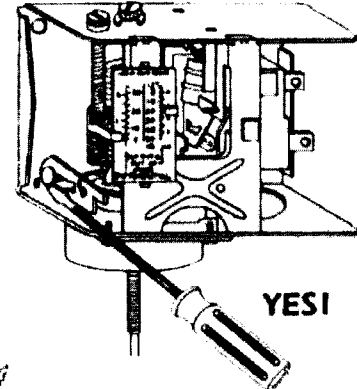
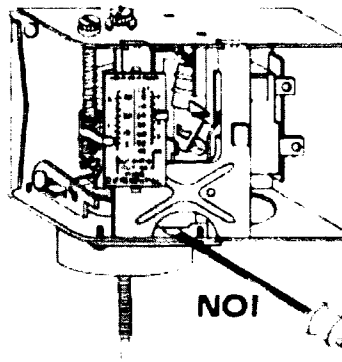
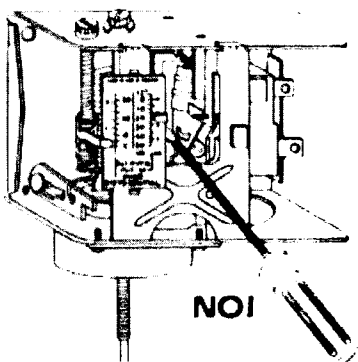

CONTROL BODY MOUNTING

It is important not to twist or strain the control body as shifting of the calibration may result.

RANCO dual pressure controls can be mounted in any position, either vertically or horizontally, without affecting performance.

The control can be mounted on an existing bracket, on the angle bracket provided, or can be flush-mounted without a bracket. No other holes are to be cut or drilled in the control frame.

1. Secure the control to either an existing bracket or the angle bracket provided by using at least two of the tapped holes in the back of the control with the 10-32x3/16 screws..

If other mounting screws are used, they must not protrude into the control more than 1/8" to avoid damage.

2. When using the angle bracket, the control can be mounted to the compressor or any flat surface by using two or more of the four slotted holes in the base of the angle bracket.

NOTE: The control also can be flush mounted without the bracket by using the .20 inch holes in the back of the control frame. Access can be gained by removing the front cover and securing the control body to a wall or any flat surface. Mounting to an uneven surface may cause improper control operation.

CAPILLARY CARE AND MOUNTING

Compressors vibrate. Copper work-hardens and fractures when flexed beyond its physical limits. Combine these two factors and broken capillaries can result. Breakage can be prevented by proper installation practices.

1. Minimize the number of times the capillary is bent. Each time it is rebent, it work-hardens making it more susceptible to breakage.
2. Avoid sharp bends, kinks, strains or pinch marks in the capillary. Never allow the capillary to rest against sharp edges or rub against metal surfaces where it can be damaged by friction.
3. The capillary should be straight within 4 inches of the pressure connection so the pulsations do not work-harden the capillary.
4. Purge all tubing and lines before connecting pressure controls.
5. Route the capillary so that it will be self-draining to minimize oil logging.

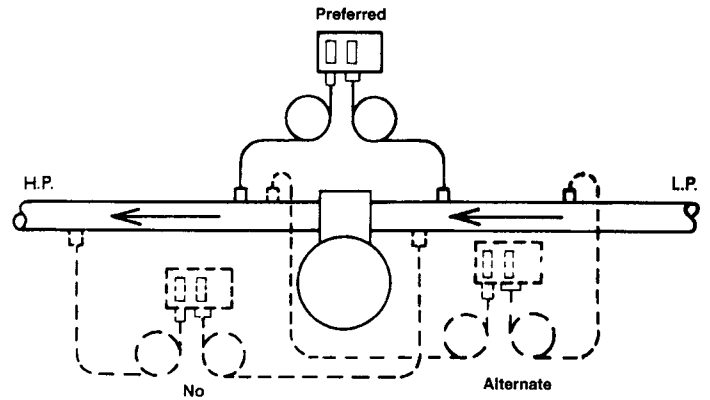

6. When the control is mounted directly on the compressor, the capillary must be secured to the compressor so that everything moves together. If the capillary or control is shaking or vibrating against the compressor vibration, work-hardening of the capillary may occur, leading to eventual failure.

COMPRESSOR MOUNTING

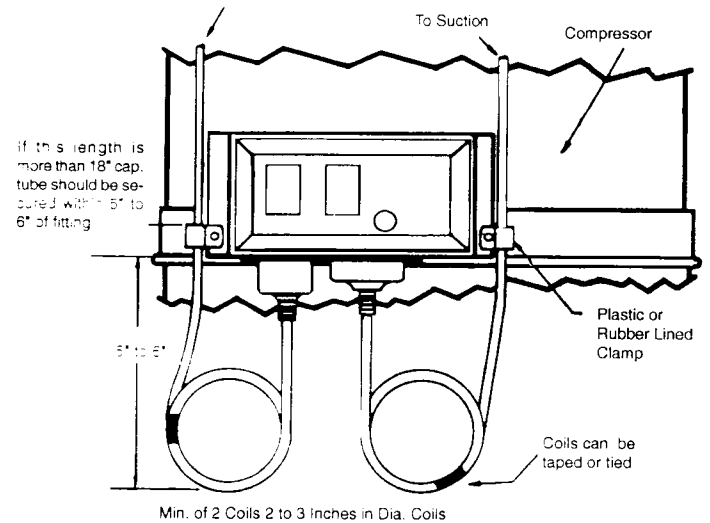

7. When the control body is mounted remote from the compressor and the pressure connections are on the compressor, a vibration coil must be used between the compressor and the mounted control.

The capillary between the pressure connection and the vibration coil should be secured to the compressor.

REMOTE MOUNTING

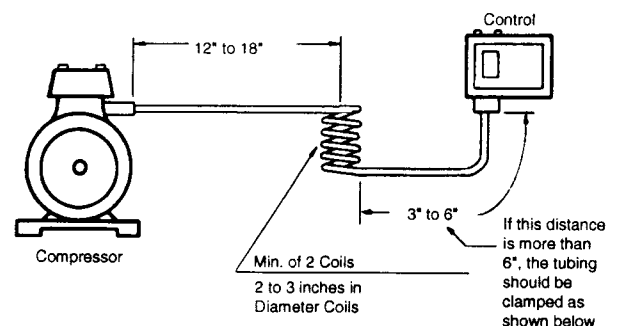

The capillary between the vibration coil and the control body should be secured to a stationary member when that distance exceeds 6 inches.

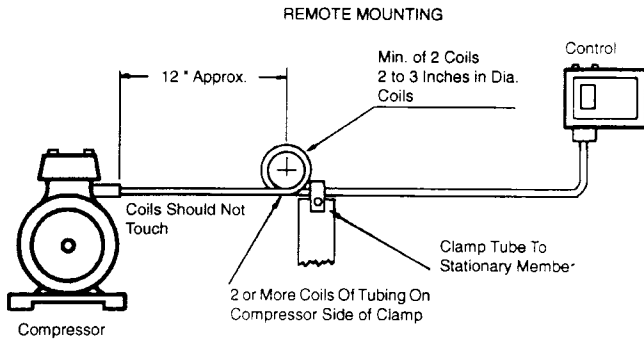

CONTROL ADJUSTMENTS

Control settings are to be as specified by the equipment manufacturer and as required for the application. DO NOT adjust the pointers beyond the highest or lowest marks on the scaleplate. The scaleplate is only for reference and the final control settings should be verified with a gauge set.

As a final check, the system should be run through several cycles to assure proper settings and installation.

LOW PRESSURE SIDE (cut-in on rise)

The cut-out setting should never be lower than 18 to 20 inches of vacuum on R12 and single stage R22 and R502 systems should never be set lower than 0 PSIG to 3 inches of vacuum. Excessively low settings can cause compressor damage.

NOTE: A control with manual reset on the low side has a scaleplate that directly indicates the cut-out and has a fixed differential of approximately 10 PSI. A control with automatic reset on the low side, has a scaleplate that directly indicates the **cut-in** and **differential** (difference between cut-in and cut-out). The cut-out is calculated as follows:

1. Adjust the low pressure range screw until the scale pointer indicates the desired **cut-in**. Turning the range screw clockwise lowers both the **cut-in** and the cut-out; counterclockwise raises both.
2. Adjust the differential screw until the scale pointer indicates the desired **differential**. Turning the differential screw clockwise increases the differential; counterclockwise decreases.

The cut-out is calculated by subtracting the differential from the cut-in setting. 20" of vacuum is the lowest attainable cut-out.

CONTROL WIRING

1. Disconnect electrical power to the unit.
2. All electrical wiring should conform to the National Electrical Code and local regulations.
3. The electrical ratings inside the control cover must not be exceeded.
4. When mounting a conduit connector to the control frame, care is to be taken so that the control mechanism or the hinge pin is not damaged during installation.
5. Attach electrical leads to the switch terminals using the screws provided. The terminals must not be bent, cut off, drilled or retapped. Electrical leads must not be taut; slack must be allowed for temperature change and vibration. The terminal configurations are shown below.

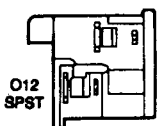

LOW SIDE

CLOSES HIGH
OPENS LOW



HIGH SIDE

OPENS HIGH
CLOSES LOW

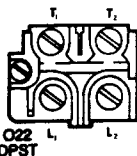

CLOSES HIGH
OPENS LOW



OPENS HIGH
CLOSES LOW



EXAMPLE:

$$\begin{array}{rcccl} \text{Cut-In} & \text{Differential} & \text{Cut-Out} & & \\ 36 & - & 20 & = & 16 \end{array}$$

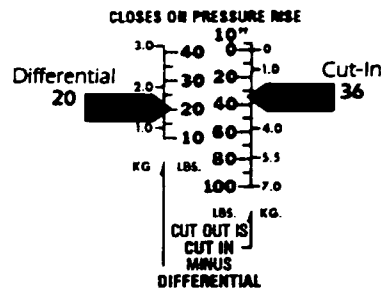

LOW PRESSURE CUT-OUT CHECK

The low pressure side can be precalibrated by using a container of refrigerant and a gauge set. Use a continuity meter to indicate the closing and opening of the switch. Adjust the control to the desired settings; pressurize the control while adjusting the settings.

Low pressure settings can be rechecked when the unit is running by connecting a gauge to the suction line service valve. Close the liquid line valve and allow the system to pump down, observing the cut-out point. Then open the liquid line valve and allow the pressure to increase, observing the cut-in point. Adjust the settings as necessary.

HIGH PRESSURE SIDE (cut-out on rise)

The high pressure function has a fixed differential of 50 or 60 psi depending upon the control model. This means that in order for the control to reset, the pressure must drop 50-60 psi below the cut-out.

NOTE: Some controls are equipped with high pressure limit stops. Although the high pressure range can be adjusted, the factory set limit stop prevents adjustment higher than the limit stop setting. DO NOT attempt to force the adjustment beyond the limit stop setting.

Adjust the high pressure range screw until the scale pointer indicates the desired cut-out setting. Turning the screw clockwise lowers the cut-out; counterclockwise raises.

HIGH PRESSURE CUT-OUT CHECK

The high pressure cut-out can be checked by disconnecting the fan or by blocking the air flow on air cooled condensers. On water cooled condensers, reduce or shut off the water flow while observing the cut-out and adjust as required. CAUTION: These checks must be for a brief time only.

MANUAL RESET

Before resetting the control, the cause of the abnormal pressure should be determined and corrected. Controls equipped with a manual reset feature can be reset by depressing the reset bar or reset button. However, before the control can be reset, the high pressure must drop 50-60 psi below the control cut-out. If the control is a manual reset on the low side, the pressure must rise approximately 10 psi above the control cut-out.

CONVERTIBLE (Manual/Automatic) RESET

Many dual function controls are equipped with a manual/automatic reset capability for high pressure. The reset function is selected by positioning the selector screw atop the control in an up position for manual reset, or down for automatic reset. After the screw is positioned, the nut must be relocked.

SPECIFICATIONS									
Low Pressure		High Pressure		Reset		O12		O22	
Range P.S.I.G.	Differential P.S.I.	Range P.S.I.G.	Differential P.S.I.	Low Pressure	High Pressure	Male Flare	36" Capillary with Flare Nut	48" Capillary with Flare Nut	36" Capillary with Flare Nut
12" to 50	5 to 35	100 to 250	50 Fixed	Automatic	Automatic	O12-1505	O12-1506	O12-1554	-
				Automatic	Auto/Man** (Convertible)	-	-	-	O22-7702
		150 to 450	60 Fixed	Automatic	Automatic	-	O12-1502	-	-
				Automatic	Auto/Man** (Convertible)	-	-	O12-4833	-
10" to 100	10 to 40	150 to 450	60 Fixed	Automatic	Automatic	O12-1550	O12-1549	-	-
				Automatic	Auto/Man** (Convertible)	-	-	O12-4834	O22-7706
				Manual*	Manual**	-	O12-1594	-	-

* Locks open pressure decrease **Locks open on pressure increase.



RANCO CONTROLS

Wholesale & Replacement
Parts Division
555 London Road
Delaware, Ohio 43015
(614) 876-8022

Copyright 1985, Ranco Incorporated
All Rights Reserved
Form #1531039