

SC228 HANGER ROD STIFFENER

- For $\frac{3}{8}$ " thru $\frac{5}{8}$ " ATR
- Strut ordered separately
- Standard finish: ZN
- Wt./C 21 Lbs. (9.5 kg)

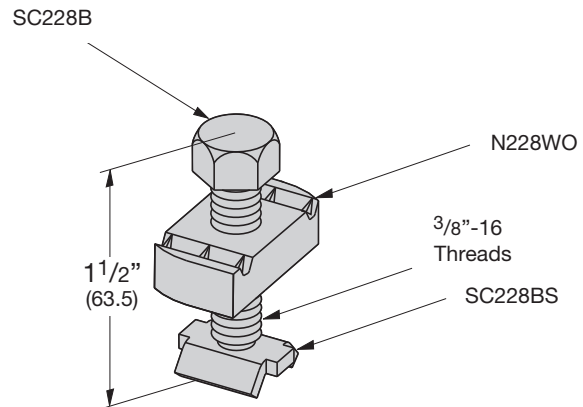
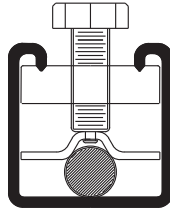

Fig. 98 ROD STIFFENER

- For $\frac{3}{8}$ " thru $\frac{7}{8}$ " ATR
- Use with 12 ga. strut only, ordered separately
- Secures channel to hanger rod for vertical seismic bracing
- Standard finish: ZN
- Wt./C 11 Lbs. (5.0 kg)

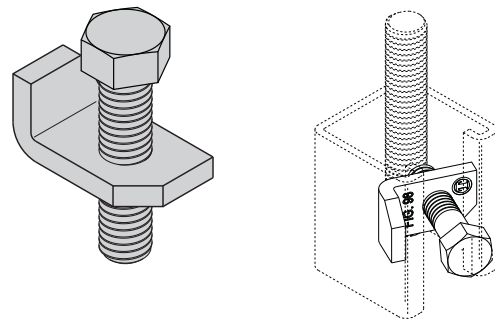
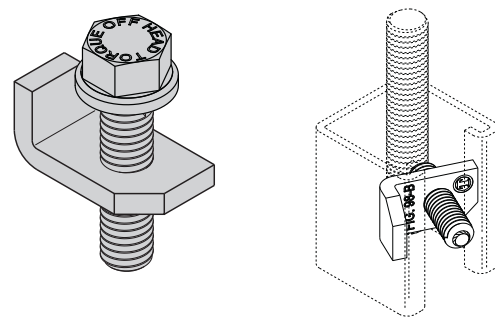

Fig. 98B ROD STIFFENER w/BREAK-OFF BOLT HEAD

- For $\frac{3}{8}$ " thru $\frac{7}{8}$ " ATR
- Use with 12 ga. strut only, ordered separately
- Secures channel to hanger rod for vertical seismic bracing
- Uses a snap-off bolt head
- Standard finish: ZN
- Wt./C 13 Lbs. (5.9 kg)



SC-UB HANGER ROD STIFFENER

- For $\frac{3}{4}$ " thru $\frac{7}{8}$ " ATR
- Strut ordered separately
- Includes: (1) B3188-1 $\frac{1}{2}$ WO U-Bolt
- (2) $\frac{3}{8}$ "-16 Hex Nuts
- (1) 2-Hole Plate
- Standard finish: ZN
- Wt./C 50 Lbs. (22.7 kg)

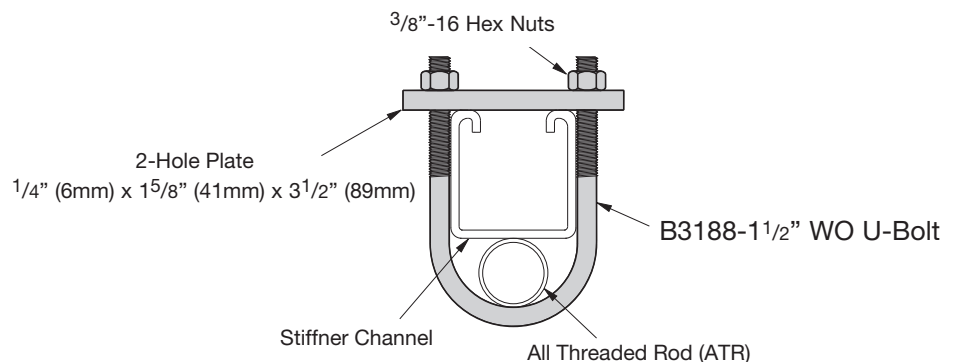

Reference page 44 for general fitting and standard finish specifications.

Hardware

ATR

ALL THREADED ROD

- Available in 36" (91.4 cm), 72" (182.9 cm), 120" (304.8 cm), 144" (365.7 cm) lengths
- Safety Factor of 5 on recommended load
- Standard finish: Zinc-Plated, Stainless Steel Type 304

Part No. & Size	Threads Per Inch	Recommended Load		Wt./C Ft. (3048.0 cm)	
		Lbs.	kN	Lbs.	kg
ATR 1/4"	20	240	(1.07)	12	(5.44)
ATR 5/16"	18	400	(1.78)	19	(8.62)
ATR 3/8"	16	730	(3.24)	29	(13.15)
ATR 1/2"	13	1350	(6.00)	53	(24.04)
ATR 5/8"	11	2160	(9.60)	89	(40.37)
ATR 3/4"	10	3230	(14.37)	123	(55.79)
ATR 7/8"	9	4480	(19.93)	170	(77.11)
ATR 1"	8	5900	(26.24)	225	(102.06)

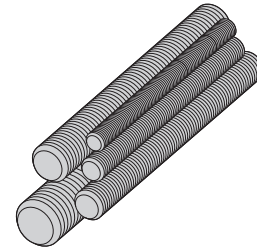

B655 ROD COUPLING B656 REDUCER ROD COUPLING

- Load rating for each coupler meets All Threaded Rod value
- Standard finish: Zinc-Plated, Stainless Steel Type 304

Part No.	Size	Recommended Load		Length	Wt./C	
		Lbs.	kN		Lbs.	kg
B655-1/4	1/4"-20	240	(1.07)	7/8" (22.2)	1.9	(.86)
B655-5/16	5/16"-18	380	(1.69)	7/8" (22.2)	1.8	(.81)
B655-3/8	3/8"-16	730	(3.24)	1 1/8" (28.6)	3.6	(1.63)
B655-1/2	1/2"-13	1350	(6.00)	1 3/4" (44.4)	11.3	(5.12)
B655-5/8	5/8"-11	1810	(8.05)	2 1/8" (54.0)	17.6	(7.98)
B655-3/4	3/4"-10	2710	(12.05)	2 1/4" (57.1)	28.1	(12.74)
B655-7/8	7/8"-9	3770	(16.77)	2 1/2" (63.5)	57.2	(25.94)
B655-1	1"-8	4960	(22.06)	2 3/4" (69.8)	73.7	(33.43)

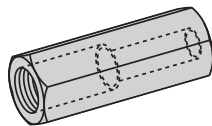
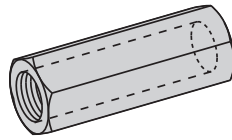

Part No.	Size	Recommended Load		Length	Wt./C	
		Lbs.	kN		Lbs.	kg
B656-3/8 x 1/4	3/8"-16 & 1/4"-20	240	(1.07)	1" (25.4)	3.7	(1.68)
B656-1/2 x 3/8	1/2"-13 & 3/8"-16	730	(3.24)	1 1/4" (31.7)	6.6	(2.99)
B656-5/8 x 1/2	5/8"-11 & 1/2"-13	1350	(6.00)	1 1/4" (31.7)	11.6	(5.26)
B656-3/4 x 5/8	3/4"-10 & 5/8"-11	1810	(8.05)	1 1/2" (38.1)	20.6	(9.34)
B656-7/8 x 3/4	7/8"-9 & 3/4"-10	2710	(12.05)	1 3/4" (44.4)	39.4	(17.87)

BHR SERIES HOT RODS FOR TRAPEZE HANGERS

- 12" length of threaded rod completely assembled with rod coupling, locking hex nuts, square washer, and channel nut.
- Standard finish: Zinc-Plated

Part No.	Rod Size	Recommended Load		Wt./C	
		Lbs.	kN	Lbs.	kg
BHR1225ZN	1/4"-20	240	(1.07)	41	(18.6)
BHR1238ZN	3/8"-16	730	(3.24)	63	(28.6)
BHR1250ZN	1/2"-13	1350	(6.00)	98	(44.4)
BHR1262ZN	5/8"-11	1500	(6.67)	148	(67.1)

Note: Based on use with 12 ga. channel.

(BHR1225, BHR1238, and BHR1250 use combo nut washers instead of square washers and channel nuts)

Reference page 44 for general fitting and standard finish specifications.

