

TOOLS AND INSTRUMENTS

TEMPERATURE GUNS

RAYNGER IP SERIES

The Raynger IP models are hand-held, battery powered, noncontact thermometers that plug directly into thermocouple meters with type J or type K inputs.

PART NO.	DESCRIPTION
IP-J	-18° to 260° C (0° to 500° F) D:S = 4:1. Type "J" T/C output
IP-K	-18° to 260° C (0° to 500° F) D:S = 4:1. Type "K" T/C output

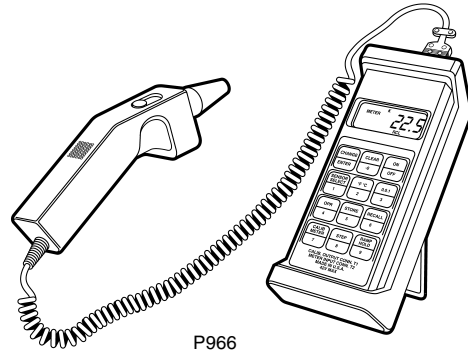

P966

RAYNGER ST SERIES

Four models to choose from:

ST20 Pro

ST30 Pro

ST60 ProPlus

ST80 ProPlus

- **ST20 Pro:** Standard model with single laser sighting, and temperature range of -32 to 400° C (-25 to 750° F)
- **ST30 Pro:** Standard model with 8 point circular laser sighting, which helps define the target being measured. It also has a larger temperature range of -32 to 545° C (-25 to 950° F)
- **ST60 ProPlus:** Enhanced model with 8 point circular laser, high/low alarm, MAX, MIN, DIF, and AVG temperature settings, and a temperature range of -32 to 600° C (-25 to 1100° F). It also has adjustable emissivity, and a D : S ratio of 30 : 1.
- **ST80 ProPlus:** This model has all the features of the ST60 ProPlus, but with an expanded temperature range of -32 to 760° C (-25 to 1400° F) and optics that allows the user to measure smaller objects from farther away. This is great news for HVAC or facilities maintenance professionals who need to measure ceiling and duct temperatures from a distance

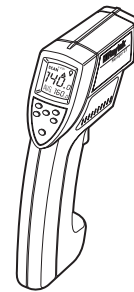

P2063

Features include:

- 8 point Circular laser sightings (ST20 has single laser)
- 12 point data logging (ST60/80)
- RTD contact probe (ST60/80)
- Adjustable emissivity (ST60/80)
- Comfortable, ergonomic design
- Rubber overmold for durability and comfort
- Hard case

Features	ST20	ST30	ST60	ST80
Temperature Range:	-32 to 400° C (-25 to 750° F)	-32 to 545° C (-25 to 950° F)	-32 to 600° C (-25 to 1100° F)	-32 to 760° C (-25 to 1400° F)
D:S (Distance to Spot size):	12:1	12:1	30:1	50:1
Laser Sighting:	Single Spot	8 point	8 point	8 point
Emissivity:	pre-set to 0.95	pre-set to 0.95	adjustable	adjustable
Accuracy:	±1%	±1%	±1%	±1%
Response Time:	500 mSec	500 mSec	500 mSec	500 mSec
MAX, MIN, DIF, and AVG Temperatures:	MAX only	MAX only	All	All
Recall Last Reading:	No	No	Yes	Yes
HI/LO Alarm:	No	No	Yes	Yes
Protective Hard Case:	Yes	Yes	Yes	Yes

TOOLS AND INSTRUMENTS

TEMPERATURE GUNS (cont)

RAYNGER MX SERIES

Raynger MX models are handheld, battery powered, noncontact thermometers that are lightweight, accurate, and easy to use. All MX thermometers include Raytek's NEW innovative laser sighting — a 16 point holographic image that outlines your target area, graphic displays on screen, adjustable emissivity (0.1 to 1.50), 1/10° resolution, and a distance to spot of 60:1. (At 60 feet from your target - you will measure the average temperatures of a 1 foot spot). All units include a hard plastic carry case.

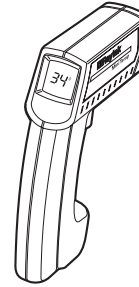

P2064

PART NO.	DESCRIPTION
MX2	Standard model, visible and audible HI alarm, 1% accuracy graphics displays, multiple displays at one time of maximum, minimum, and current temperatures, -30 to 900°C (-25 to 1600°F) Other models available. Contact your distributor.

Innovative Features.

- On-board emissivity table
- Measures contact & IR temperature, simultaneously
- Customizable log location
- Bar graph charts last 10 temperature points

Additional Features of MX Series

Temperature Range	-30 to 900° C (-25 to 1600° F)
D:S (Distance to Spot Size)	60:1
Laser Sighting	16-point, class 2
Emissivity	Adjustable
Accuracy	±1%
Response Time	250mSec
°C or °F	Selectable
Protective Hard Case	Included
Data output	RS-232 or 1 mV per degree

TOOLS AND INSTRUMENTS

RAYTEK MINITEMP SERIES

The Raytek MiniTemp is a hand-held, battery operated, non-contact thermometer that fits in your pocket.

PART NO.	RAYMT2U	RAYMT4U
Temperature Range:	-18 to 260° C (0 to 500° F)	-18 to 260° C (0 to 500° F)
D:S (Distance to Spot Size):	6:1	6:1
Laser Sighting:	No	Yes
Emissivity:	Pre-set to 0.95	Pre-set to 0.95
Accuracy:	2%	2%
Response Time:	500 m Sec	500 m Sec

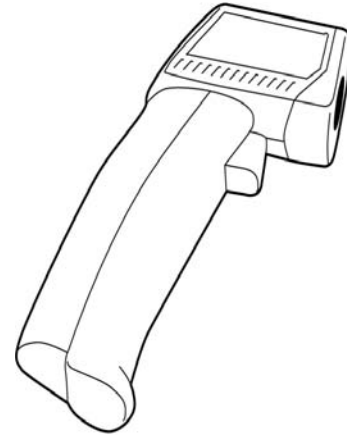

P1553

- Powered by 9V alkaline or NiCd battery
- LCD Backlight
- Can display temperature in °C or °F
- Holds display for 7 seconds

SWIRLJET® OUTFITS

For faster soldering and brazing

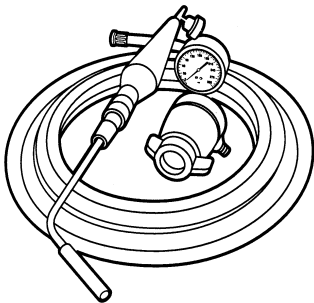

pg642b

- Superhot flame from SWIRLJET tips will silver or alloy-braze pipe faster than a conventional flame
- More effective - flame concentrates heat on work where needed - less waste
- Shorter wrap-around flame allows soldering of joints within an inch of walls or woodwork without damaging or discoloring
- Efficient - for use under all weather conditions; wind will not deflect high velocity flame
- Adjustable pressure with contents

gauge and delivery pressure indicators on pressure adjustment knob

- Two outfits available - one for acetylene; one for FG-2, MAPP, or propane in refillable tanks

APPLICATION	PART NO.
For Acetylene B Tank	POL-998623
For Refillable FG-2, MAPP, or Propane Tank	POL-999147

TOOLS AND INSTRUMENTS

SWIRL AIR ACETYLENE KITS

X-3B Kit (0386-0335)

Flexible kit brazes light/medium gauge steel.

Components:

- AR-B (CGA 520) Regulator
- G-4 Handle
- AH-12 Hose
- A-3 Tip
- A-11 Tip
- Soft solders to 3" (75mm)
- Silver brazes to 1-5/8" (40mm)
- "B" Tank Connection
- Instruction Manual

X-4B Kit (0386-0336)

Higher capacity kit brazes medium/heavy gauge steel.

Components:

- AR-B (CGA 520) Regulator
- G-4 Handle
- AH-12 Hose
- A-5 Tip
- A-14 Tip
- Soft solders to 3-1/2" (90mm)
- Silver brazes to 2" (50mm)
- "B" Tank Connection
- Instruction Manual

X-5B Kit (0386-0338)

Flexible lighter-duty kit.

Components:

- AR-B (CGA 520) Regulator
- G-4 Handle
- AH-12 Hose
- A-5 Tip
- Soft solders to 1-1/2" (40mm)
- Silver brazes to 3/4" (20mm)
- "B" Tank Connection
- Instruction Manual

X-5MC Kit (0386-0384)

Flexible lighter-duty kit.

Components:

- AR-MC (CGA 200) Regulator
- G-4 Handle
- AH-12 Hose
- A-5 Tip
- Soft solders to 1-1/2" (40mm)
- Silver brazes to 3/4" (20mm)
- "MC" Tank Connection
- Instruction Manual

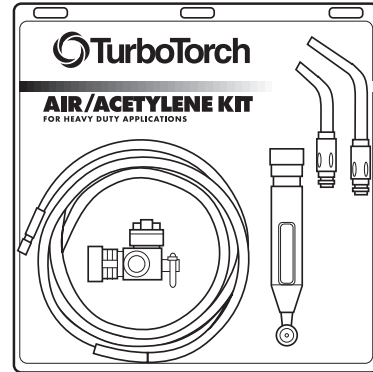

X-6MC Kit (0386-0339)

All-purpose kit for work using "MC" tank.

Components:

- AR-MC (CGA 200) Regulator
- G-4 Handle
- AH-12 Hose
- A-3 Tip
- A-8 Tip
- Soft solders to 2" (50mm)
- Silver brazes to 1" (30mm)
- "MC" Tank Connection
- Instruction Manual

MSKA-1 Kit (0386-0366)

Features quieter operation.

Components:

- AR-B (CGA 520) Regulator
- G-4 Handle
- AH-12 Hose
- MSA-8 Tip
- Soft solders to 3" (75mm)
- Silver brazes to 3/4" (20mm)
- "B" Tank Connection
- Instruction Manual

TOOLS & SUPPLIES

SWIRL AIR ACETYLENE KITS (cont)

PL-5ADLX-MC Kit (0386-0832)

Components:

- AR-MC (CGA-200) Regulator
- G4 Handle
- AH-12 Hose
- PL-5A Tip
- Soft Solders to 1-1/2" (40mm)
- Silver Brazes to 3/4" (20mm)
- "MC" Tank Connections
- Instruction Manual

PL-5ADLX-B Kit (0386-0833)

(Not Shown) "B" Tank Connection

PL-8ADLX-MC Kit (0386-0834)

Components:

- AR-MC (CGA-200) Regulator
- G4 Handle
- AH-12 Hose
- PL-8A Tip
- Soft Solders to 2" (50mm)
- Silver Brazes to 1" (30mm)
- "MC" Tank Connections
- Instruction Manual

PL-8ADLX-B Kit (0386-0835)

(Not Shown) "B" Tank Connection

PL-12ADLX-B (0386-0836)

Components:

- AR-B (CGA-520) Regulator
- G4 Handle
- AH-12 Hose
- PL-12A Tip
- Soft Solders to 3-1/2" (90mm)
- Silver Brazes to 2" (50mm)
- "B" Tank Connections
- Instruction Manual

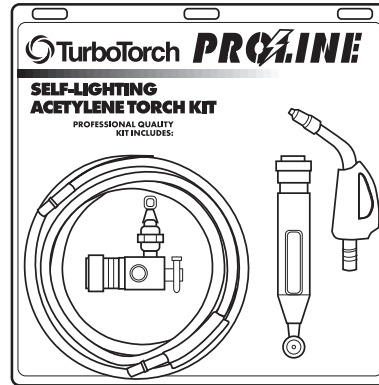

PRO-LINE™ with valve forward handle.

Components: Except for valve forward handle, kits use same components as PL rear valve kits shown above.

Description: Part No.

PLF-5A-DLX-MC 0386-0864 (Not Shown)

PLF-5A-DLX-B0386-0865

Description: Part No.

PLF-8A-DLX-MC 0386-0866

PLF-8A-DLX-B0386-0867 (Not Shown)

Description: Part No.

PLF-8A-DLX-MC 0386-0866

PLF-8A-DLX-B 0386-0867 (Not Shown)

SWIRL AIR ACETYLENE TIPS

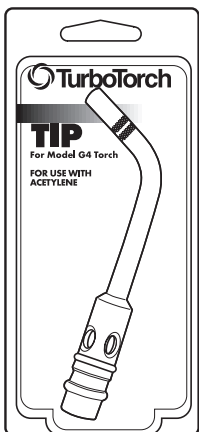

A-5
(0386-0102)

TIP NO.	TIP SIZE		GAS FLOW		COPPER TUBING SIZE CAPACITY				REPLACEMENT ORIFICE MODEL
	in.	mm	@ 14 psi ft ³ /hr	(0.9 bar) m ³ /hr	Soft Solder		Silver Braze		
					in.	mm	in.	mm	
A-2	1/8	4.8	2.0	.17	1/8-1/2	3-15	1/8 - 1/4	3-10	OR-A2
A-3	3/16	6.4	3.6	.31	1/4-1	10-25	1/8 - 1/2	3-12	OR-A3
A-5	1/4	7.9	5.7	.48	3/4 - 1-1/2	20-40	1/4 - 3/4	10-20	OR-A5
A-8	5/16	9.5	8.3	.71	1-2	25-50	1/2-1	15-25	OR-A8
A-11	7/16	11.1	11.0	.94	1-1/2 - 3	40-75	7/8 - 1-5/8	20-40	OR-A11
A-14	1/2	12.7	14.5	1.23	2 - 3-1/2	50-90	1-2	30-50	OR-A14
A-32*	3/4	19.0	33.2	2.82	4-6	100-150	1-1/2 - 4	40-100	OR-A32
MSA-8	3/8	9.5	5.8	.50	3/4 - 3	20-75	1/4 - 3/4	10-20	OR-A5

*Use with large tank only. NOTE: For air conditioning, add 1/8" for type "L" tubing.

TOOLS & SUPPLIES

SWIRL AIR ACETYLENE TIPS (cont)

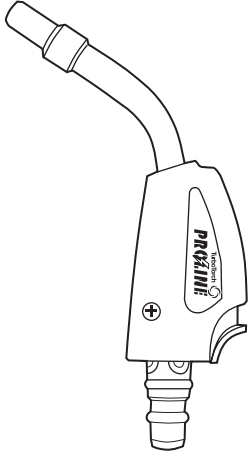

PL-3A
(0386-0874)

TIP NO.	TIP SIZE		GAS FLOW		COPPER TUBING SIZE CAPACITY				REPLACEMENT ORIFICE MODEL	REPLACEMENT TIP ENDS
	in.	mm	@ 14 psi ft ³ /hr	(0.9 bar) m ³ /hr	Soft Solder		Silver Braze			
					in.	mm	in.	mm		
PL-3A	1/4	5.0	3.6	.31	1/4-1	10-25	1/8 - 1/2	3-12	OR-A3	3A-TE
PL-5A	3/16	6.4	5	.42	3/4 - 1-1/2	20-40	1/4 - 3/4	10-20	OR-A8	5A-TE
PL-8A	5/16	7.9	7	.59	1-2	25-50	1/2 - 1	15-30	ORPL-8A	8A-TE
PL-12A	3/8	9.5	9	.76	2-4	50-90	1 - 2	25-50	OR-T-6	12A-TE

NOTE: For air conditioning, add 1/8" for type "L" tubing.

TOOLS & SUPPLIES

SWIRL AIR ACETYLENE COMPONENTS

SA Snappy Adapter (0386-0500)

Screws into Sof-Flame or other threaded handles adapting it to the TurboTorch Quick Disconnect tips. Provides the advantages of TurboTorch at lowest cost.

Acetylene Hose

AH-12 (0386-1090)

AH-24 (0386-1091)

3/16" I.D. with 3/8" 24-thread LH nuts. Fits G4 and PLF-A Handle, AR-B (CGA-520) & AR-MC (CGA-200) regulators. AH-12, 12 ft. (3.6m) hose.

PLF-A5 Pro-Line Handle (0386-0872)

Ergonomically designed handle with valve and quick disconnect. Fits all Proline and TurboTorch tips. "A" size 3/8"-24 Hose Connection.

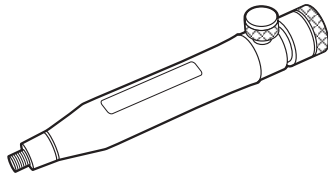

TT-MC (1421-0035)

Heavy duty steel construction fits "MC" tank or MT-1 MAPP® tank. Easy storage of tips, handle, hose and striker.

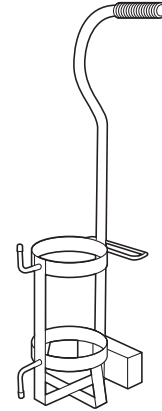

G-4 TurboTorch Handle (0386-0308)

Ergonomically designed handle with valve and quick disconnect. Fits all Proline and TurboTorch tips. "A" size 3/8"-24 Hose Connection.

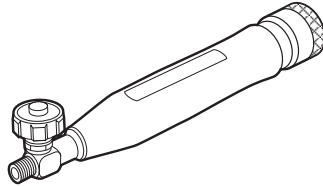

TT-150 (1421-0016)

Durable composite construction fits "B" tank. A heavy nylon belt can keep your outfit secure on scaffolds or in the truck.

- Large Handle
- Hose Rack
- Accessory Holder

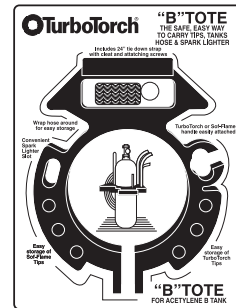

Acetylene Regulators

AR-B (0386-0725)

AR-MC (0386-0726)

Brass construction, adjustable with contents gauge. AR-B (CGA-520), fits "B" tank & 3/8" 24-thread LH hose nut. AR-MC (CGA-200) fits "MC" tank & 3/8" 24-thread LH hose nut.



TOOLS & SUPPLIES

SOF-FLAME™ ACETYLENE KITS & TIPS

Kits now include gauge guard and cylinder wrench

WSF-3 Kit (0386-0089)

Components:

- AR-MC (CGA 200) Regulator
- WA-400 Handle
- AH-12 Hose
- S-4 Tip
- Soft Solders to 1" (25mm)
- "MC" Tank Connection
- Instruction Manual

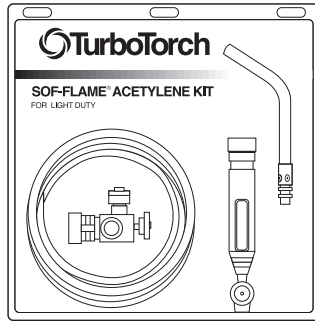

WA-400 Handle (0386-0410)

- "A" Size 3/8" 24 LH Hose Threads, Interchangeable with brands of equipment
- Requires no tools for tip change
- Tips can be locked in any position
- Stainless steel ball valve for added durability
- Replaceable O-ring seal for safety
- Accepts Snappy Adapter

WSF-4 Kit (0386-0090)

Components:

- AR-B (CGA 520) Regulator
- WA-400 Handle
- AH-12 Hose
- S-4 Tip
- Soft Solders to 1" (25mm)
- "B" Tank Connection
- Instruction Manual

Sof-Flame™ Tips Improved design for excellent flame characteristics!

- Replaces old style "W" series.
- Solid Brass construction • Fits WA-400 torch handle

S-1 (0386-1153)

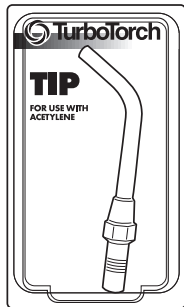

MODEL	SOFT SOLDERS		OPERATING PRESSURE RANGE		ACETYLENE CONSUMPTION RANGE		REPLACEMENT ORIFICE NO.
	in.	mm	PSI	BAR	SCFH	m ³ /hr	
S-1	1/16-1/8	2-3	5-15	.35-1.0	.53-.89	.04-.07	OR-SI
S-2	1/8-3/8	3-9	5-15	.35-1.0	1.0-1.7	.08-.14	OR-A2
S-3	3/8-1/2	9-13	5-15	.35-1.0	1.9-3.2	.15-.26	OR-T3
S-4	1/2-1	13-25	5-15	.35-1.0	3.5-5.9	.29-.49	OR-A5
S-5	3/4 - 1-1/2	19-40	5-15	.35-1.0	6.6-11.0	.55-.92	OR-A11
S-6	1-4	25-100	5-15	.35-1.0	8.8-14.8	.73-1.24	OR-A14

TOOLS & SUPPLIES

SWIRL PROPANE & MAPP® KITS

Kits now include gauge guard and cylinder wrench

LP-1 Kit (0386-0247)

Components:

- R-LP Adjustable Regulator, CGA-510
- H-4 Handle
- H-12 Hose
- T-4 Tip
- T-6 Tip
- Soft solders to 6" (150mm)
- Silver brazes to 4" (100mm)
- Instruction Manual

LP-3 Kit (0386-0006)

Components:

- R-LP Adjustable Regulator, CGA-510
- H-4 Handle
- H-12 Hose
- T-4 Tip
- Soft solders to 2-1/2" (60mm)
- Silver brazes to 1-1/4" (30mm)
- Instruction Manual

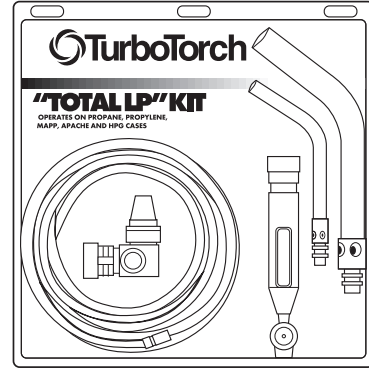

LP-2 Kit (0386-0007)

Components:

- R-LP Adjustable Regulator, CGA-510
- H-4 Handle
- H-12 Hose
- T-3 Tip
- T-5 Tip
- Soft solders to 4" (100mm)
- Silver brazes to 2" (50mm)
- Instruction Manual

NOTE: TurboTorch "LP" torches and Pro-Line® torches operate on Propane, Propylene, MAPP®, Apachi® and HPG. TurboTorch/Pro-line® torches use the hotter high energy gases for maximum heat, and propane for economy where high heat is not necessary.

SWIRL PROPANE & MAPP® TIPS/COMPONENTS

Turbo-Torch Tips

Count on total performance from TurboTorch MAPP® & Propane tips.

Varying size tips help you get the job done - quick and easy!

T-2 (0386-0150)

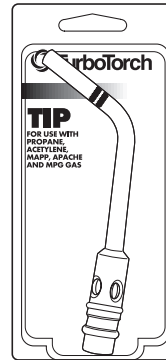

With
Color Coded
O-Rings
BLUE for LP

TIP NO.	TIP SIZE		GAS FLOW		COPPER TUBING SIZE CAPACITY PROPANE GAS				COPPER TUBING SIZE CAPACITY MAPP® GAS				REPLACEMENT ORIFICE MODEL
	in.	mm	@24 psi lb/hr	@36 psi lb/hr	Soft Solder		Silver Braze		Soft Solder		Silver Braze		
					in.	mm	in.	mm	in.	mm	in.	mm	
T-2	5/16	8.0	.14	.17	1/8-1/4	3-10	1/16-1/4	1-6	1/8-1/2	3-12	1/8-1/4	3-10	OR-A2
T-3	7/16	11.1	.20	.25	1/4-1	6-25	1/8-1/2	3-10	1/4-1-1/2	10-40	1/4-1/2	6-15	OR-T3
T-4	1/2	12.7	.39	.48	1/4-1-1/2	10-40	1/4-3/4	6-15	1/4-2-1/2	10-60	1/4-1-1/4	6-35	OR-A3
T-5	3/4	19.0	1.10	1.3	1-1/2-2-1/2	25-60	1/2-1-1/4	15-35	1-4	25-100	1/2-2	15-50	OR-A8
T-6	1	25.4	2.10	2.5	1-1/2-4	40-100	3/4-2	20-50	1-1/2-6	25-150	3/4-4	20-100	OR-T6

TT-B (1421-0034)

Heavy duty steel construction fits "B" tank. Storage for tips, hose, handle and striker.

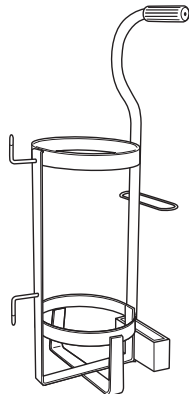

TOOLS & SUPPLIES

SWIRL PROPANE & MAPP® KITS — PRO-LINE™ WITH REAR VALVE HANDLE

PL-3TDLX Kit (0386-0837)

Components:

- RL-P Regulator, CGA-510
- H-4 Handle
- H-12 Hose
- PL-3T Tip
- Soft Solders 1" (25mm)
- Silver Brazes 1/2" (12mm)
- Instruction Manual

PL-5TDLX Kit (0386-0839)

Components:

- RL-P Regulator, CGA-510
- H-4 Handle
- H-12 Hose
- PL-5T Tip
- Soft Solders 2-1/2" (63mm)
- Silver Brazes 1-1/4" (31mm)
- Instruction Manual

PL-4T STD Kit (0386-0830)

Components:

- H-4 Handle
- PL-4T Tip

PRO-LINE™ Standard Kit.

PL-4TDLX Kit (0386-0838)

Components:

- RL-P Regulator, CGA-510
- H-4 Handle
- H-12 Hose
- PL-4T Tip
- Soft Solders 1-1/2" (40mm)
- Silver Brazes 3/4" (20mm)
- Instruction Manual

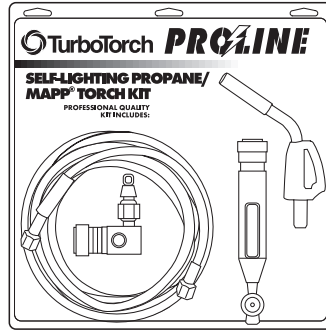

SWIRL PROPANE & MAPP® TIPS/COMPONENTS — PRO-LINE™

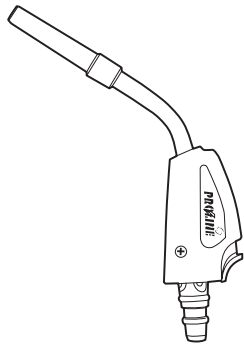

PL-3T (0386-0821)

Soldering & Brazing sizes based on Propane. Capacity larger on MAPP® gas.

With
Color Coded
O-Rings

BLUE for LP

PRO-LINE Tips

TIP NO.	TIP SIZE		AIR PROPANE		AIR MAPP®		COPPER TUBING SIZE CAPACITY PROPANE GAS				COPPER TUBING SIZE CAPACITY MAPP® GAS				REPLACEMENT	
	in.	mm	@24 psi lb/hr	@42 psi lb/hr	Soft Solder		Silver Braze		Soft Solder		Silver Braze		Orifice Model	Tip Ends		
					in.	mm	in.	mm	in.	mm	in.	mm				
PL-3T	3/8	9.5	.33	.46	1/4-1	6-25	1/8-1/2	3-10	1/4 - 1-1/2	10-40	1/4-1/2	6-15	OR-T-3	3T-TE		
PL-4T	7/16	11.1	.52	.69	1/4-1-1/2	10-40	1/4-3/4	6-15	1/4 - 2-1/2	10-60	1/4 - 1-1/4	6-35	OR-PL4T	4T-TE		
PL-5T	5/8	15.9	.71	1.41	1-1/2 - 2-1/2	40-60	1/2 - 1-1/4	15-35	1-4	25-100	1/2-2	15-50	OR-PL5T	5T-TE		

“Total LP” Hose

H-12 (1412-0080)

H-24 (0386-1087)

3/16" I.D. T Grade hose with 9/16" 18 LH Thread. Fits H-4 handle, T-8 torch, R-LP adjustable LP regulator. H-12, 12 ft. (3.6m) hose H-24, 24 ft (7.3m) hose

R-LP Regulator

(0386-0705)

Brass regulator for use with MAPP®, Propane and other LPG fuel gas. Adjustable to 60 psi. Fits standard POL valve & 9/16" 18 LH hose nut. Not for use with Acetylene.

R-LP-993 Regulator for British 993 Markets, Part No. 0386-0328

H-4 Handle

(0386-0300)

Ergonomically designed handle with valve rear and quick disconnect. Fits all Proline and TurboTorch tips. “B” size 9/16"-18 hose connection

TOOLS & SUPPLIES

HAND TORCHES & COMPONENTS

PROPANE AND MAPP® GASES

- Torches are built with TurboTorch swirl combustion
- All models have 360° swivel tips
- Easy-to-clean orifice, replaceable tips
- Designed to operate with a tank of either MAPP® or Propane gas
- Hand Torch line lets you choose the gas for silver brazing copper tubing, bronze brazing steel pipe, or soldering with water in the line.

STK-99 Kit (0386-0851)

Components:

- STK-R Pressure Regulator CGA-600
- ST-33 Tip
- Easy to Change Orifice
- Swivels 360°
- Instruction Manual

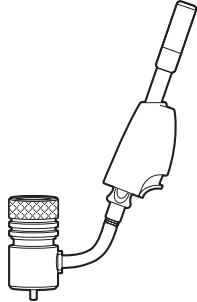

STK-8B Kit (0386-0404)

Components:

- STK-R Pressure Regulator CGA-600
- ST-3 Tip
- L-1 Striker
- Packed in Handy, Rugged Plastic Box
- Instruction Manual

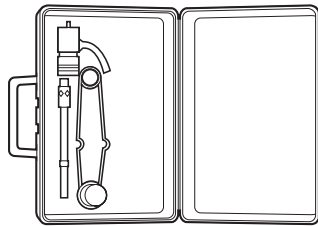

STK-9 Kit (0386-0403)

Components:

- STK-R Pressure Regulator CGA-600
- ST-3 Tip
- Easy to Change Orifice
- Swivels 360°
- Instruction Manual

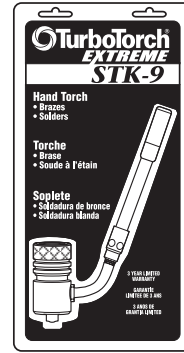

STK-1 Kit (0386-0408)

Components:

- STK-R Pressure Regulator CGA-600
- ST-1 Tip
- Easy to Change Orifice
- Swivels 360°
- Instruction Manual



TOOLS & SUPPLIES

PROPANE & MAPP® HAND TORCHES

PROPANE AND MAPP® GASES

ST-33 Self-Igniting Tip Assembly Only (0386-0850)

- Fits existing STK-9 and STK-99 torches



44TL-TE Self-Lighting Tip End (0386-1263)

- Fits ST-33, STK-99 & TL-44

STK-R Regulator (0386-0687)

Adjustable pressure regulator CGA 600. Use with MAPP® or Propane tanks. Fits ST tips and TS-12 hose.

Hand Torch Tips

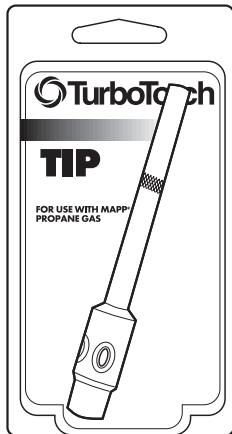

ST-1 (0386-0170)

TIP NO.	COPPER TUBING SIZE CAPACITY WITH MAPP® GAS				REPLACEMENT ORIFICE NO.
	Soft Solder		Silver Braze		
	in.	mm	in.	mm	
ST-1	1/8-1/2	3-12	1/2-3/8	10-12	STOR-1
ST-3	3/8 - 2-1/2	10-60	1/4 - 1-3/8	6-35	STOR-3
ST-4	1-3/8 - 2-1/2	35-60	1/4 - 1-3/8	6-35	STOR-3
ST-5	1/8-1/2	3-12	1/2-3/8	10-12	STOR-1

TOOLS & SUPPLIES

SELF-LIGHTING TORCHES & KITS

PROPANE AND MAPP® GASES

TL-44 TurboLite® Self-Lighting Torch (0386-1273 TurboTorch swirl combustion technology)

- Gives you the best burn in a self-lighting package.
- Flame tube swivels 180° for easy positioning.
- MAPP® or Propane gas without changing the Orifice.
- Workplace-designed without exposed wires.
- Trigger Lock
- Performance equivalent to T-3 LP tip.

Features:

- Replaceable tip-end
- Easy to clean orifice
- Heavy-duty piezo ignitor
- Machined rotor
- Wide lighting range

Use with

- CGA 600, 1 lb. MAPP® or Propane Tanks. Tank not included

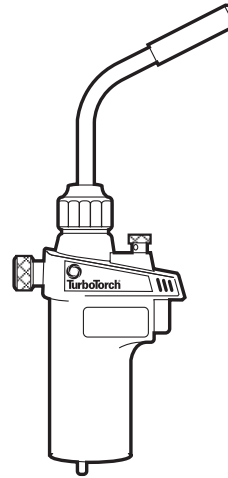

TLK-41 (0386-1270)

Allows remote operation with a 1lb. refillable cylinder

- TL-44 Torch
- 163-01T Adapter
- TS-12 Hose
- STK-R Regulator CGA-600

Use of TSR tank rack is recommended

TLK-44 TurboLite® Self-Lighting Torch Kit (0386-1272)

Components:

- TL-44 TORCH
- Plastic Carrying Case

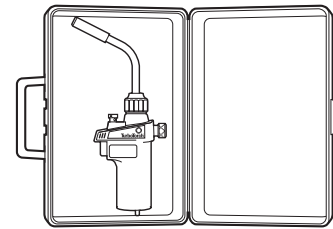

PRO-LINE® Self-Lighting Snake Kit) (Does not include gas)

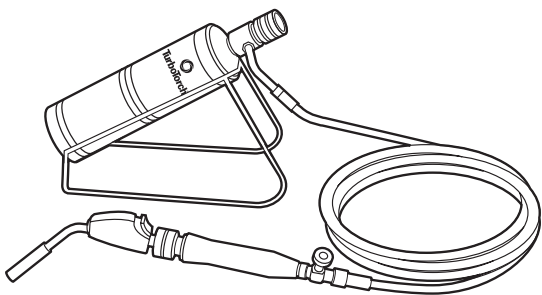

The swirl combustion tip gives you the best burn and cuts brazing time by 30%. Flame tube swivels 360° for work at any angle. Push trigger ignition. Rugged brass regulator. Offered with either #3 or #4 size tip with replaceable tip. Runs cool, quietly and efficiently.

Components:

- Self-Lighting Propane & MAPP® Tip
- TSR Tank Rack with Retainer
- Ergonomically designed handle
- STK-R Regulator CGA-600
- 12 ft. of Hose

• Model No. PS-3T Pro-Snake Kit Size 3 (0386-0840)

• Model No. PS-4T Pro-Snake Kit Size 4 (0386-0841)

TOOLS & SUPPLIES

SELF-LIGHTING TORCHES & KITS (cont)

PROPANE AND MAPP® GASES

TS-1B Kit (0386-0230) (Does not include gas)

Makes easy work of soldering in hard-to-reach places. Soft solders up to 2-1/2" (60mm) and silver brazes up to 1-3/8" (35mm). Can be used with MAPP® or Propane

Components:

- ST-4 Tip
- TSH Handle
- TS-12, 12 ft. (3.7m) Hose Assembly
- STK-R Regulator, CGA-600
- MT-1 MAPP® Tank
- TSR Tank Rack with Retainer
- Instruction Manual

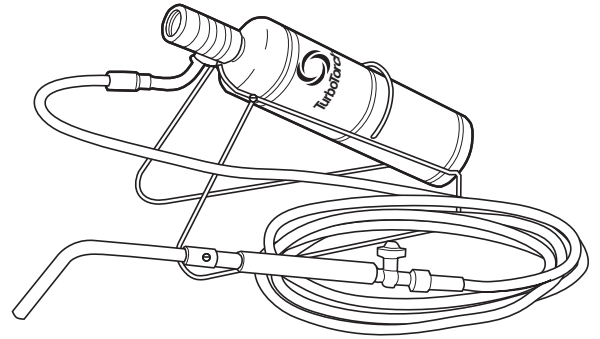

TP-10 Pencil Flame Propane Torch (0386-0860)

- Solid brass construction for lasting durability
- Flame control valve for precise heat adjustments
- May be used with any 14.1 oz. propane tank
- Great for light application jobs:
 - Soldering
 - Thawing frozen pipes
 - Loosening rusty nuts & bolts
 - Heating
 - Light maintenance

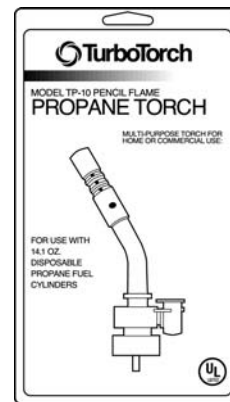

TOOLS & SUPPLIES

CUTTING & BRAZING EQUIPMENT — CWK SERIES KITS “A” CONNECTIONS

CWK-4 Kit (0386-0051)

Components:

- 221-05FP Oxygen Regulator CGA-540
- 201-05FP Acetylene Regulator CGA-200
- 103-01FP Handle
- 152-01FP Cutting Attachment
- 2-W-J Nozzle with Mixer
- 0-3-101 Cutting Tip
- Reverse Flow Check Valves
- 252-03P 3/16" x 12 1/2 ft. Twin Hose
- 251-01P Goggle
- 141-01 Carrying Case & Instruction Booklet

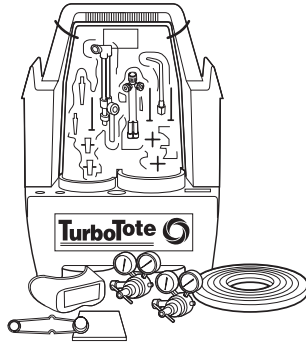

Listed
Components

CWK-5 Kit (0386-0055)

Components:

- 221-05FP Oxygen Regulator CGA-540
- 201-05FP Acetylene Regulator CGA-200
- 103-01FP Handle
- 2-W-J & 4-W-J Nozzle with Mixer
- Reverse Flow Check Valves
- 252-03P 3/16" x 12 1/2 ft. Twin Hose
- 251-01P Goggle
- 141-01 Carrying Case & Instruction Booklet

CWK-2T Kit (0386-0045)

Components:

- 221-05FP Oxygen Regulator CGA-540
- 201-05FP Acetylene Regulator CGA-200
- 103-01FP Handle
- 152-01FP Cutting Attachment
- 0-3-101 Cutting Tip
- 0-W-J, 2-W-J and 4-W-J Nozzle with Mixer
- Reverse Flow Check Valves
- 252-03P 3/16" x 12 1/2 ft. Twin Hose

CWK-4T Kit (0386-0054)

Components:

- Same as CWK-4 Kit plus
- AC-MC & OX-20 Tanks

CWK-5T Kit (0386-0058) (not shown)

- Same as CWK-5 Kit plus
- AC-MC & OX-20 Tanks

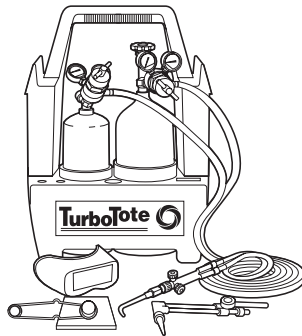

Replacement Nozzles & Mixers for CWK Series

MODEL NO.	PART NO.	TIP SIZE	BRAZING CAPACITY FOR COPPER TUBING	USED WITH THESE HANDLES	CONFIGURATION
000-W-J-CS	0387-0038	000	1/8 - 1/2" (3-12mm)	103-01FP	Complete w/Nozzle Mixer
00-W-J-CS	0387-0039	00	1/8 - 3/4" (3-19mm)	103-01FP	Complete w/Nozzle Mixer
0-W-J-CS	0387-0040	0	1/4 - 1" (6-25mm)	103-01FP	Complete w/Nozzle Mixer
1-W-J-CS	0387-0041	1	1/4 - 1-1/4" (6-31mm)	103-01FP	Complete w/Nozzle Mixer
2-W-J-CS	0387-0042	2	1/2 - 1-1/2" (12-38mm)	103-01FP	Complete w/Nozzle Mixer

Replacement Cutting Tips for CWK Series

MODEL NO.	PART NO.	TIP SIZE	CUTTING CAPACITY	GAS SERVICE	USED WITH THESE CUTTING ATTACHMENTS
00-3-101-CS	0387-0144	00	to 1/4" (6mm) material	Acetylene	151-01FP and 152-01FP
0-3-101-CS	0387-0145	0	to 1/2" (12mm) material	Acetylene	
1-3-101-CS	0387-0146	1	to 3/4" (19mm) material	Acetylene	
2-3-101-CS	0387-0147	2	to 1" (25mm) material	Acetylene	
160-02P	0386-1231		Adapter Air/Acetylene Only, used on 103-01FP Handle		

*CS indicates clamshell package.

TOOLS & SUPPLIES

CUTTING & BRAZING EQUIPMENT — 100 SERIES KITS “B” CONNECTIONS

110-01FP Kit (0386-0038)

Components:

- 221-05FP Oxygen Regulator CGA-540
- 201-05FP Acetylene Regulator CGA-200
- 101-01FP Handle with Flash Arrestors
- 151-01FP Cutting Attachment
- 163-01P “B” to “A” Adapter
- 000-W-1, 0-W-1 & 2-W-1 Nozzles
- 0-3-101 Cutting Tip
- 252-03P 3/16” A Size x 12 1/2 ft. Twin Hose
- 251-01P Goggles, L-1 Striker & Instruction Booklet
- 141-01 Carrying Case

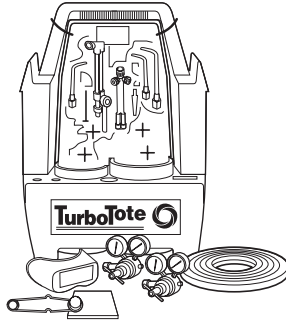

111-01FP Kit (0386-0039)

Components:

- 221-05FP Oxygen Regulator CGA-540
- 201-05FP Acetylene Regulator CGA-200
- 101-01FP Handle with Flash Arrestors
- 151-01FP Cutting Attachment
- 163-01P “B” to “A” Adapter
- 000-W-1, 0-W-1 & 2-W-1 Nozzles
- 0-3-101 Cutting Tip
- 252-03P 3/16” A Size x 12 1/2 ft. Twin Hose
- 251-01P Goggles, L-1 Striker & Instruction Booklet
- 160-01 Air/Gas Adapter
- A-5 Acetylene Tip
- 141-01 Carrying Case

110-01FPT Kit (0386-0479)

Components:

- 221-05FP Oxygen Regulator CGA-540
- 201-05FP Acetylene Regulator CGA-200
- 101-01FP Handle with Flash Arrestors
- 151-01FP Cutting Attachment
- 163-01P “B” to “A” Adapter
- 000-W-1, 0-W-1 & 2-W-1 Nozzles
- 0-3-101 Cutting Tip
- 252-03P 3/16” x 12 1/2 ft. Twin Hose
- 251-01P Goggles, L-1 Striker & Instruction Booklet
- 141-01 Carrying Case
- AC-MC & OX-20 Tanks Included

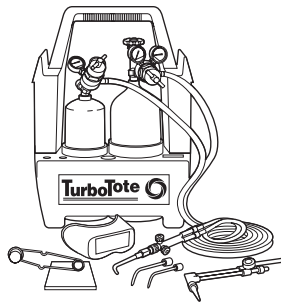

Replacement Cutting Tips for 100 Series

MODEL NO.	PART NO.	TIP SIZE	CUTTING CAPACITY	GAS SERVICE	USED WITH THESE CUTTING ATTACHMENTS
00-3-101-CS	0387-0144	00	to 1/4” (6mm) material	Acetylene	151-01FP and 152-01FP
0-3-101-CS	0387-0145	0	to 1/2” (12mm) material	Acetylene	
1-3-101-CS	0387-0146	1	to 3/4” (19mm) material	Acetylene	
2-3-101-CS	0387-0147	2	to 1” (25mm) material	Acetylene	
160-02P	0386-1231		Adapter Air/Acetylene Only, used on 103-01FP Handle		

*CS indicates clamshell package.

Replacement Nozzles & Mixers for 100 Series

MODEL NO.	PART NO.	TIP SIZE	BRAZING CAPACITY FOR COPPER TUBING	USED WITH THESE HANDLES	CONFIGURATION
000-W-J-CS	0387-0038	000	1/8 - 1/2” (3-12mm)	103-01FP	Complete w/Nozzle Mixer
00-W-J-CS	0387-0039	00	1/8 - 3/4” (3-19mm)	103-01FP	Complete w/Nozzle Mixer
0-W-J-CS	0387-0040	0	1/4 - 1” (6-25mm)	103-01FP	Complete w/Nozzle Mixer
1-W-J-CS	0387-0041	1	1/4 - 1-1/4” (6-31mm)	103-01FP	Complete w/Nozzle Mixer
2-W-J-CS	0387-0042	2	1/2 - 1-1/2” (12-38mm)	103-01FP	Complete w/Nozzle Mixer

NOTE: Oxygen consumption (SCFH) is 1.1 times acetylene for a neutral flame.

TOOLS & SUPPLIES

OXYGEN-ACETYLENE CUTTING & BRAZING EQUIPMENT

REPLACEMENT HANDLES & CUTTING ATTACHMENTS FOR CWK SERIES

103-01FP Handle (0386-0311)



- Forward valves ribbed barrel for sure grip.
- "A" Hose Fittings, 3/8"-24
- Threaded joints provide easier service
- Control valves use stainless steel ball stems and teflon packing for smooth gas-tight operation

152-01FP Cutting Attachment (0386-0380)



- Use with 103-01FP Handle
- Internal spiral mixer mixes oxygen and fuel for optimum performance
- Smooth action of cutting oxygen valve allows precise control
- Stainless steel lever for durability
- Double O-ring seal
- Stainless steel tubes for superior strength

REPLACEMENT HANDLES & CUTTING ATTACHMENTS FOR 100 SERIES

101-01FP Handle (0386-0310)



- Built in flashback arrestors and reverse flow check valves for added safety
- Threaded joints provide easier service
- Control valves use stainless steel ball stems and teflon packing for smooth gas tight operation
- Rear valves
- Ribbed barrel stock for sure grip
- "B" 9/16"-18 hose fittings

151-01FP Cutting Attachment (0386-0380)



- Use with 101-01FP Handle
- Internal spiral mixer mixes oxygen and fuel for optimum performance
- Smooth action of cutting oxygen valve allows precise control
- Stainless steel lever for durability
- Double O-ring seal

REPLACEMENT ACETYLENE & OXYGEN REGULATORS



201-05FP



221-05FP

MODEL NO.	PART NO.	HIGH PRESSURE GAUGE		LOW PRESSURE GAUGE		DELIVERY RANGE	
		P.S.I.G.	KPA	P.S.I.G.	KPA	P.S.I.G.	KPA
201-05FP Acetylene CGA-200	0386-0784	400	2800	30	210	2-15	14-105
221-05FP Oxygen CGA-540	0386-0786	4000	28,000	100	700	4-80	28-570

REPLACEMENT GAUGES

PART NO.	DESCRIPTION
1424=0147	1 1/2" x 30 lbs. gauge
1424=0148	1 1/2" x 100 lbs. gauge
1424=0149	1 1/2" x 400 lbs. gauge
1424=0150	1 1/2" x 4000 lbs. gauge

TOOLS & SUPPLIES

OXY/ACETYLENE SPECIALTY TIPS & ACCESSORIES

“Tough jobs made easy” with our new line of small brazing tips.

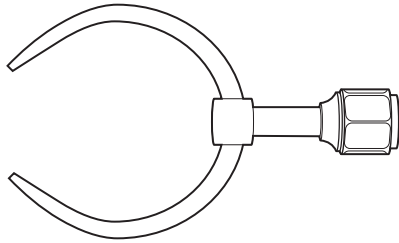

D-1

Dual Flame Twin Tips

For flexibility and control.

Model D-1 Part No. 0386-0545
Braze capacity: 1/4"-7/8"

Model D-2 Part No. 0386-0546
Braze capacity: 1/2"-1 1/8"

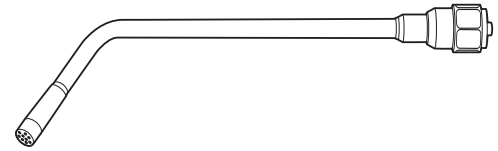

Multi-Flame Heating Nozzles

For heating, straightening, bending, brazing. Spiral Mixer provides optimum flame characteristics.

Model VMA-J-15 Part No. 0325-0109

For use with CWK Series handle.

Braze capacity: 1/8"-2 5/8"

Model VMA-1-15 Part No. 0324-0114

For use with 100 Series handle.

Braze capacity: 1/8"-2 5/8"

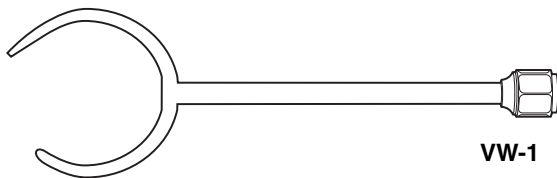

VW-1

Wrapper Tips

For complete distribution.

Model VW-1 Part No. 0386-0547
Braze capacity: 1/2"-1"

Model VW-2 Part No. 0386-0548
Braze capacity: 5/8" - 1 1/8"

Model VW-3 Part No. 0386-0549
Braze capacity: 7/8" - 1 5/8"

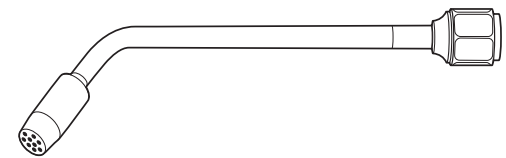

Multi-Flame Heating Tip

For maximum heating in a confined area.

Model VMA Part No. 0386-0544

Braze capacity: 1/4"-1 3/4"

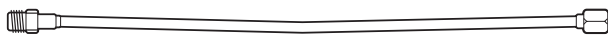

E-6

Tip Extensions

Target those hard to reach places.

Model E-6 Part No. 0386-0556
6" Flexible extension

Model E-10 Part No. 0386-0557
10" Flexible extension

Mixer-Adapters

For TurboTorch oxy-acetylene handles.

Model VM-J Part No. 0386-0554
Fits CWK kit handle
#103-01FP (Forward valve)

Model VM-I Part No. 0386-0555
BraFits 110 kit handle
#101-0FP (Rear valve)

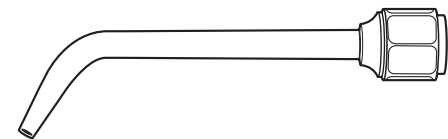
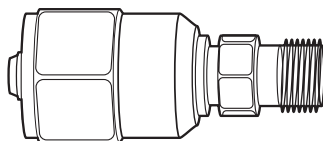

V-1

Single Flame Tips

Pin-point precise heat.

Model V-1 Part No. 0386-0551 Size 1
Braze capacity: 1/4"-7/8"

Model V-2 Part No. 0386-0552 Size 2
Braze capacity: 1/2" - 1"

Model V-3 Part No. 0386-0553 Size 3
Braze capacity: 5/8" - 1 1/8"

TOOLS & SUPPLIES

NITROGEN PURGING EQUIPMENT & ACCESSORIES



Purging Regulator (245-03P)



TurboTorch offers a nitrogen regulator with easy to read 2" (51 mm) gauges. Constructed of forged brass, designed for testing and purging brazed joints. This regulator is recommended by many air conditioning code organizations for joint testing at commercial job sites.

MODEL NO.	PART NO.	H.P. GAUGE		L. P. GAUGE		DELIVERY RANGE	
		P.S.I.G.	KPA	P.S.I.G.	KPA	P.S.I.G.	KPA
245-02P Nitrogen CGA-580	0386-0813	4000	28,000	400	2800	0-250	0-1750
245-03P Nitrogen CGA-580	0386-0814	4000	28,000	600	4200	0-500	0-3500

*Gauges scale = PSIG/KPA

Replacement Gauges

PART NO.	DESCRIPTION
1424=0019	2" x 4000 lbs. gauge
1424=0017	2" x 400 lbs. gauge
1424=0381	2" x 600 lbs. gauge

TT-LP TurboTest Refrigerant Leak Detector (0386-0443)

The TurboTest "Total LP" Leak Detector fits standard TurboTorch MAPP® (MT-1) or Propane (PT-1) tanks. The TurboTest "Total LP" is compact, easy to use and capable of detecting leaks of 8 oz. per year. It's made of brass construction with a stainless steel shield. Sniffer tube swivels 360° for easy handling. Heavy copper reactor plate (TT-R-LP) gives extra long life, yet is easily replaceable. Rugged stainless steel shroud will not rust. Easy-to-clean orifice is easily removed, reversed and blown clean. Steady, uniform swirl combustion flame. Complete operating instructions are included.



NITROGEN PURGE & BLOW GUN KITS

NPK-20 (0386-1234)

- 6 ft/1.8m hose
- OSHA rated blow gun
- Regulator 245-03P
- Carrying Case
- Multiple Uses: purges, blows, leak tests

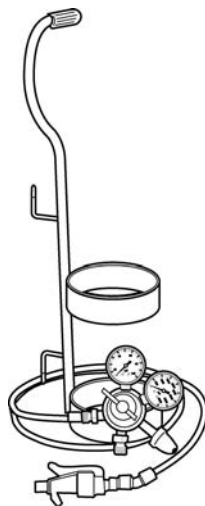

NPK-40 (0386-1236)

- 6 ft/1.8m hose
- OSHA rated blow gun
- Regulator 245-03P
- Carrying Case
- Multiple Uses: purges, blows, leak tests

Blow Gun Accessories

MODEL NO.	PART NO.	DESCRIPTION
TT-20	1421-0058	20 cu. ft. Carrying Case
TT-40	1421-0059	40 cu. ft. Carrying Case
NT-40	0916-0028	40 cu. ft. Nitrogen Cyl.
BG	0660-0105	Blow Gun
BGH	1412-0145	Blow Gun Hose

TOOLS & SUPPLIES

BRAZING AND SOLDERING ALLOYS

Aluminum Brazing Alloy

AK-1 (0386-0423)

Aluminum brazing alloy rod and flux for aluminum products, even anodized aluminum. Ideal for refrigerant coil and tubing repair. Kit includes rod and self-cleaning flux.

Brazing Alloys for Maintenance on Steel Products

BF-1 Bronzeflow (0386-0422) (for steel materials other than stainless steel - available in 1 lb. or 25 lb. package) Brazing range 1595-1620°F (868-882°C) for low fuming bronze. Ideal for maintenance repairs on plumbing and heating. Tensile strength - 63,000 psi. Meets AWS A5.8, ASTM B-259, Federal QQR571B, MIL-R-19631B specifications.

NS-1 NicSil-Flow (0386-0431) (for stainless steel and chrome-plated products) Nickel content brazing rod. Low fuming type nickel-bronze alloy. Brazing range 1665-1680°F. Tensile strength - 70,000 psi. Meets AWS A5.8, ASTM B-259, Federal QQR571B, MIL-R-19631B specifications.

SILVER/COPPER/PHOSPHORUS BRAZING ALLOYS

These alloys are regularly used in the HVAC industry, especially for joining copper tubing. No flux is required when joining copper-to-copper. Higher silver content offers better flow control and several compositions are available to match your price/performance range. Available in a 1 lb./.45 kg.

MODEL NO.	SILVER CONTENT	CHEMICAL COMPOSITION	SPECIFICATIONS	LIQUIDUS	SOLIDUS	TYPICAL APPLICATIONS
SF-1 1 lb.	0%	0% Silver 7.1% Phosphorus Balance Copper	AWS A5.8 BCuP-2 QQB-650B	1500°F 816°C	1350°F 732°C	Moving joints Non-moving joints T-joints, swage joints, sleeves Coupling on return bends and condenser fittings
SF-2 1 lb.	2%	2% Silver 7% Phosphorus Balance Copper 0.15% All Other	AWS/A5.8 Class BCuP-6 QQB-650C Class BCuP-6	1450°F 788°C	1190°F 643°C	Extending copper tubing and pipes
SF-5 1 lb.	5%	5% Silver 6% Phosphorus Balance Copper 0.15% All Other	AWS/A5.8 Class BCuP-3 ASMESFA5.8 Class BCuP-3 QQB-650B Class BCuP-3	1500°F 816°C	1190°F 643°C	Flexible pipe connectors Refrigeration control valves (copper and brass) Joining copper wires to rotor bars
SF-6 1 lb.	6%	6% Silver 6.5% Phosphorus Balance Copper 0.15% All Other	—	1425°F 774°C	1190°F 643°C	Building up control valves Electrical Connectors Radiant heating systems Air conditioning units Hot and cold water lines
SS-15 1 lb.	15%	15% Silver 5% Phosphorus Balance copper	AWS A5.8 QQB-650A MIL-E-15395A	1465°F 796°C	1190°F 643°C	Steam systems Heat exchanges Copper Joints

Note: .45 kg per pound, 11.34 kg equals 25 lbs.

TOOLS & SUPPLIES

TANK CARRIERS & TOTES

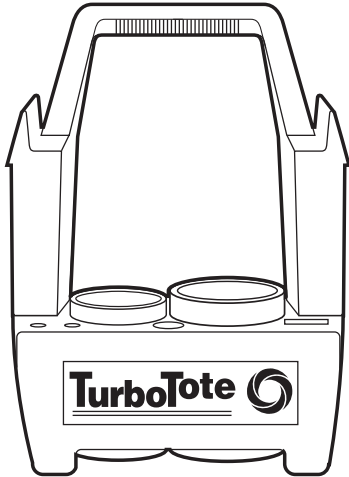

141-01 (0386-1201)

- Fits 10 cu. ft. acetylene "AC-MC" and 20 cu. ft. "OX-20" oxygen cylinders.

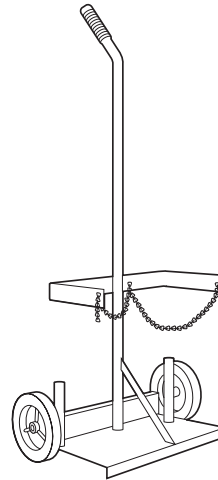

143-01 (1421-0039)

- Wheeled cylinder truck. Accommodates 40 or 10 cu. ft. acetylene and 40 or 20 cu. ft. oxygen cylinders

TSR Tank Rack (0386-0528)

- A durable wire frame and spring combination holds 1 lb. tanks securely at a 45° angle from the floor.

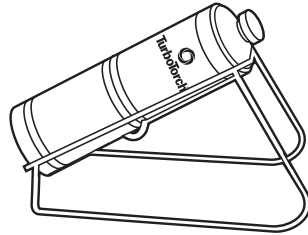

TT-150 (1421-0016)

Durable composite construction fits "B" tank. Features include a hose rack for storage while not in use and helps protect the regulator from accidental damage. A large handle keeps your tank portable. Your spark lighter is close at hand in its own holder accessory. "B" tote can be changed from one tank to another without special tools. A heavy nylon belt can keep your outfit secure on scaffolds or in the truck

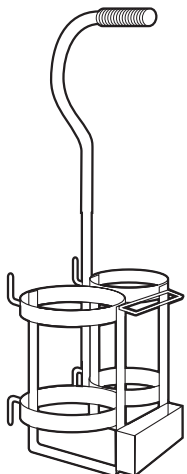

TT-MCR (1421-0036)

Heavy duty steel construction fits "MC" and "OX-20" (R) tank. Storage for tips, hose, handle and cutting attachments. Use Adapter for use with MT-1 (not included).

TT-MC (1421-0035)

Heavy duty steel construction fits "MC" tank or MT-1 MAPP® tank. Easy storage of tips, handle, hose and striker.

TT-B (1421-0034)

Heavy duty steel construction fits "B" tank. Storage for tips, hose, handle and striker.

TOOLS & SUPPLIES

CYLINDERS AND TANKS

PT-1 (0916-0004)

- Propane replacement tank for use with all TurboTorch hand torches. Also for use with TurboTorch #TT-LP Leak Detector.
- Contains 14.1 oz. propane.
- CGA 600 Connection
- Non-Refillable

MT-1 (0916-0009)

- MAPP® Gas replacement tank for use with TurboTorch dual fuel hand torches. Also use with TurboTorch #TT-LP Leak Detector.
- Contains 16 oz. of MAPP® Gas.
- CGA 600

OX-20 (0916-0003)

- Type “R” Oxygen Cylinder, 20 cu. ft. capacity.
- CGA 540 Connection
- Fits TurboTote 141-01 Case

OX-40 (0916-0019)

- Type 40 Oxygen Cylinder, 40 cu. ft. capacity.
- CGA 540 Connection

AC-B (0916-0005)

- Type “B” Acetylene Cylinder, 40 cu. ft. capacity.
- CGA 520 Connection

AC-MC (0916-0002)

- Type “MC” Acetylene Cylinder, 10 cu. ft. capacity.
- CGA 200 Connection
- Fits TURBOTOTES 141-01 CASE

T-10PS-MT (0916-0029)

- Tank with 10 lb. capacity. Refillable with Propane.
- CGA 510 POL Connection
- 17-1/2” (44cm) high
- 8” (20cm) O.D.

NT-40 (0916-0028)

- 40 cu. ft. Nitrogen Cylinder
- CGA 580 Connection

TOOLS & SUPPLIES

ACCESSORIES

Oxy/Acetylene Twin Hose

MODEL NO.	PART NO.	DESCRIPTION
252-03P	0386-1094	12-1/2 ft. Twin Hose "A" Fitting

Acetylene Hose

MODEL NO.	PART NO.	DESCRIPTION
AH-12	0386-1090	12 ft. Hose "A" Fitting
AH-24	0386-1091	24 ft. Hose "A" Fitting

"Total LP" Hose

MODEL NO.	PART NO.	DESCRIPTION
H-12	1412-0080	12 ft. Hose "B" Fitting
H-24	0386-1087	24 ft. Hose "B" Fitting

TORCH SHIELD

- **Durable Fabric**
(8" X 12") Roll it up and stuff it in **your pocket**.
- **Re-Useable**
Can be used 20, 50, 100 + Times. Will not burn or melt.
- **Center-Cut Design**
Unique design makes it easier to use.
- **Multi-Use**
Ideal for Brazing, Soldering or Welding.
- **Safe to Use**
No toxic smoke, made of non-asbestos, non-ceramic materials.

Model PL-812

Part No. (0386-0561)

L-1 Single Flint Striker (1423-0023)

Cup type, round file

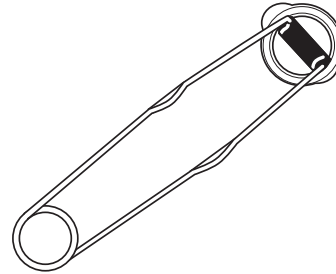

Triple Flint Striker (0386-0297)

Triple Flint Striker Refills (0386-0298)

TK Tank Key (0386-1226)

Wrench for "B" & MC" Tanks

GOGGLES 251-01P (0386-1212)

2" x 4" Goggles Shade Number 5
Coverall Style to wear over prescription or safety glasses.

TOOLS & SUPPLIES

TPC-18 AND TPC-25



TPC-18 1/8" Cutting System (1445-0900)

Specifications

- Output:** 12 amps fixed
- Input:** 120 Volts (+/-10%)
1 Phase, 60 Hz, 20 Amps
- Cut Capacity:** 1/8" (3.2mm)
- Duty Cycle:** 30%
- Panel Controls:** On/Off Lighted
- Dimensions:** Height: 10" (254mm)
Width: 9" (229mm)
Length: 16" (406mm)
- Weight:** 63 lb (25Kg)
- Gas:** Air from built in air compressor
- Pilot:** Electrode to Tip
- Control:** Torch mounted switch
- Lead Length:** 20 ft (6.1m)



TPC-25 1/8" Cutting System (1445-0901)

Specifications

- Output:** 20 amps fixed
- Input Power:** 120 V (+/- 10%) 1 Phase,
60 Hz, 20 amp
- Cut Capacity:** 1/4" (6.4 mm)
- Duty Cycle:** 40%
- Panel Controls:** On/Off Pressure regulator
- Dimensions:** Height: 3.25" (337 mm)
Width: 6.75" (172 mm)
Length: 17.5" (445 mm)
- Weight:** 40 lb. (18.2 kg)
- Gas:** Air/N2
- Gas Pressure:** 50 PSI (3.5 BAR)
- Gas Flow:** 135 SCFH (64 lpm)
- Pilot:** Electrode to tip
- Control:** Torch mounted switch
- Lead Length:** 25.0 ft. (7.6 m)

TORCH CONSUMABLES Ordering Information

Part No.	Model No.	Description
#1 1445-0903	TSC-25	Shield Cup for TPC-18 & TPC-25 (1pk)
#2 1445-0909	T-Tip-18	Cutting tip for TPC-18 Only (5pk)
#2 1445-0902	TCT-25	Cutting tip for TPC-25 Only (5pk)
#3 1445-0905	TGD-25	Gas Distributor for TPC-18 & TPC-25 (1pk)
#4 1445-0904	TE-25	Electrode for TPC-18 & TPC-25 (5pk)

Cutting Guide Kit (1445-0907)

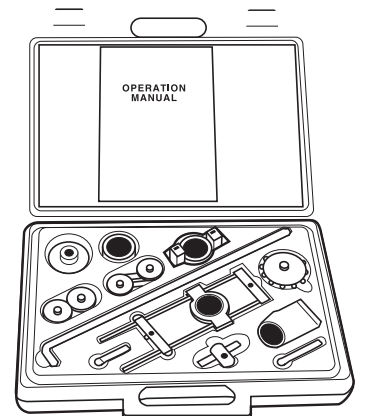

TOOLS & SUPPLIES

PRESTO-LITE® WELDING AND CUTTING OUTFITS

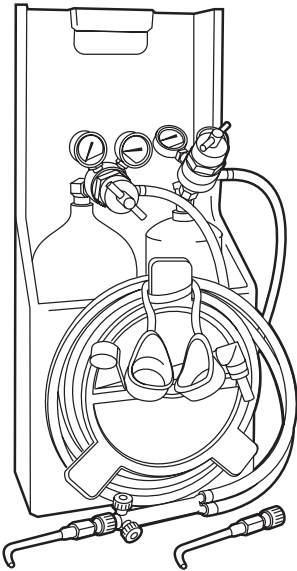

P2004

Prest-O-Lite® Outfits feature the W-200 torch handle with piston type connection for hand tightening, welding and soldering heads. Patented explosion protection is built into each regulator. The Outfit can be ordered as a Prest-O-Pak with tote or tote and tanks.

Prest-O-Lite® Maintenance Outfit

Prest-O-Pak DLX Maintenance Outfit "MC" w/Tote	600499
Prest-O-Pak DLX Maint. Outfit "MC" Tote w/Tanks	22526

Outfits Contain

W-200 Torch	999805
CW-200 Cutting Attachment	05L20
Cutting Tip 4202, 1/2 in.	16K09
Air-Gas Adaptor	639040
Air-Gas Soldering Tip #3	10X23
Brazing Tip #6	06L49
Oxygen Regulator R-22-75-540A	18564
Acetylene Regulator R-22-15-200 "MC"	05X02
Striker	790F34
Goggles	17862
Hose 12-1/2 ft. x 3/16 in. A-A "T" Grade	591F72
Tote	791F80
Optional	
Oxygen Tank "R", 20 Cu. Ft.	22457
Acetylene Tank "MC", 10 Cu. Ft.	22456

Prest-O-Lite® Brazing Outfit

Prest-O-Pak DLX Brazing Outfit "MX" w/Tote	600498
Prest-O-Pak DLX Brazing Outfit "MC" Tote w/Tanks	22527

Outfits Contain

W-200 Torch	999805
Welding Head #4	06L48
Welding Head #9	06L50
Oxygen Regulator R-22-75-540A	18564
Acetylene Regulator R-22-15-200 "MC"	05X02
Striker	790F34
Goggles	17862
Hose 12-1/2 ft. x 3/16 in. A-A "T" Grade	591F72
Tote	791F80
Optional	
Oxygen Tank "R", 20 Cu. Ft.	22457
Acetylene Tank "MC", 10 Cu. Ft.	22456

Welding, Cutting and Heating Ranges

	Outfit as furnished	Outfit with optional heads and nozzles
Welding Range	Up to 1/16 in. (1.5 mm)	Up to 3/8 in. (10 mm)
Cutting Range	Up to 1/2 in. (13 mm)	Up to 2 in. (50 mm)
Heating Range	Up to 6 cfh acet. (8,850 Btu/hr.)	Up to 40 cfh acet. (58,667 Btu/hr.)

Welding and Heating Ranges

	Outfit as furnished	Outfit with optional heads and nozzles
Welding Range	Up to 1/8 in. (3 mm)	Up to 3/8 in. (10 mm)
Heating Range	Up to 9 cfh acet. (13,300 Btu/hr.)	Up to 40 cfh acet. (58,667 Btu/hr.)

TOOLS & SUPPLIES

PRESTO-LITE® PZ503 TORCH KIT

FG-2 is the economical, high-energy fuel gas. Excellent for soldering, brazing and heating. Uses PZ-503 high output self-igniting torch with adjustable flame. Pull the trigger, it's on, release the trigger, it's off.

- High output swirl action with instant on-off
- Interchangeable burn tip converts to: general purpose flame, or pencil flame
- Heavy duty piezo igniter
- Cast aluminum body
- 100% fire tested
- Built-in pressure regulator makes it perfect for brazing or soldering in any position, even upside down!
- Has adjustable flame control for even greater versatility

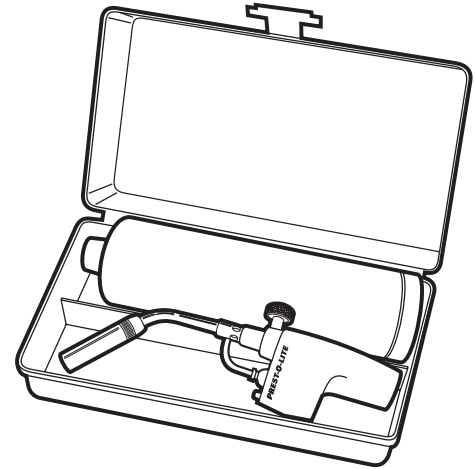

P2065

PZ503 Kit	22536
-----------	-------

	FG-2	MAPP	PROPANE
Flame Temperature in Air	3400° F	3400° F	3300° F
Cubic Feet of Gas/Pound, 70° F	9.03	8.85	8.50
Air to Gas Ratio	12:1	12:1	20:1
Cold Weather Performance	Excellent	Poor	Poor
Pressure, at 32° F, Full Cylinder	87 psig	68 psig	63 psig
Pressure, at 0° F, Full Cylinder	43 psig	30 psig	25 psig

TOOLS & SUPPLIES

AIR-ACETYLENE SWIRLJET[®] KITS

X-3B POL Kit

Flexible kit bronze brazes light/medium gauge steel

- Soft solders to 4 in. (100 mm)
- Silver brazes to 2 in. (50 mm)
- “B” tank connection

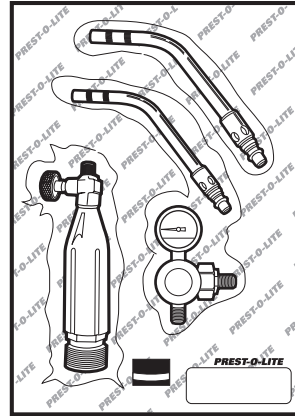

P2066

X-4B POL Kit

High capacity kit bronze brazes medium/heavy gauge steel

- Soft solders to 6 in. (150 mm)
- Silver brazes to 4 in. (100 mm)
- “B” tank connection

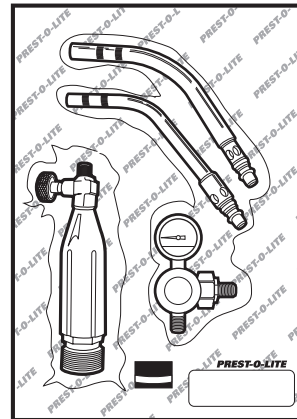

P2067

X-5B POL Kit

Flexible lighter duty kit

- Soft solders to 2 in. (50 mm)
- Silver brazes to 1 in. (25 mm)
- “B” tank connection

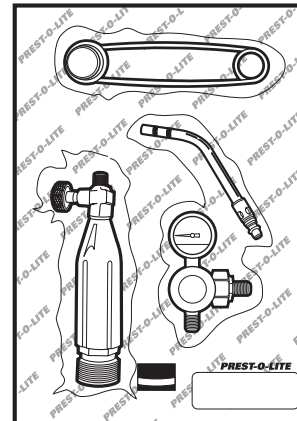

P2068

Kit Components and Ordering Information

Description	Part No.
X-3B POL Kit	21954
X-4B POL Kit	21955
Kit Contains	Part No.
R-511 “B” (CGA520) Regulator	21807
POL QD#1 Torch	21702
QD-SJ-3A Tip (X-3B only)	21703
QD-SJ-4A Tip	21704
QD-SJ-5A Tip (X-4B only)	21705
Hose 12-1/2 ft. x 3/16 in. A-A	501F12

Description	Part No.
X-5B POL Kit	21956
Kit Contains	Part No.
R-511 “B” (CGA 520) Regulator or	21807
R-511 “MC” (CGA 200) Regulator	21806
POL QD #1 Torch	21702
QD-SJ-3A Tip	21703
Hose 12-1/2 ft. x 3/16 in. A-A	501F12
Friction Lighter (X-5B only)	790F34

TOOLS & SUPPLIES

SWIRLJET® TIPS AND TORCH HANDLE

Interchangeable with Turbo Torch® and Goss® Handles and Tips

These Swirljet tips are designed to be used with the PREST-O-LITE® #1 Quick Disconnect torch handle. They run quieter and cooler and give better heat transfer than other comparable tips.

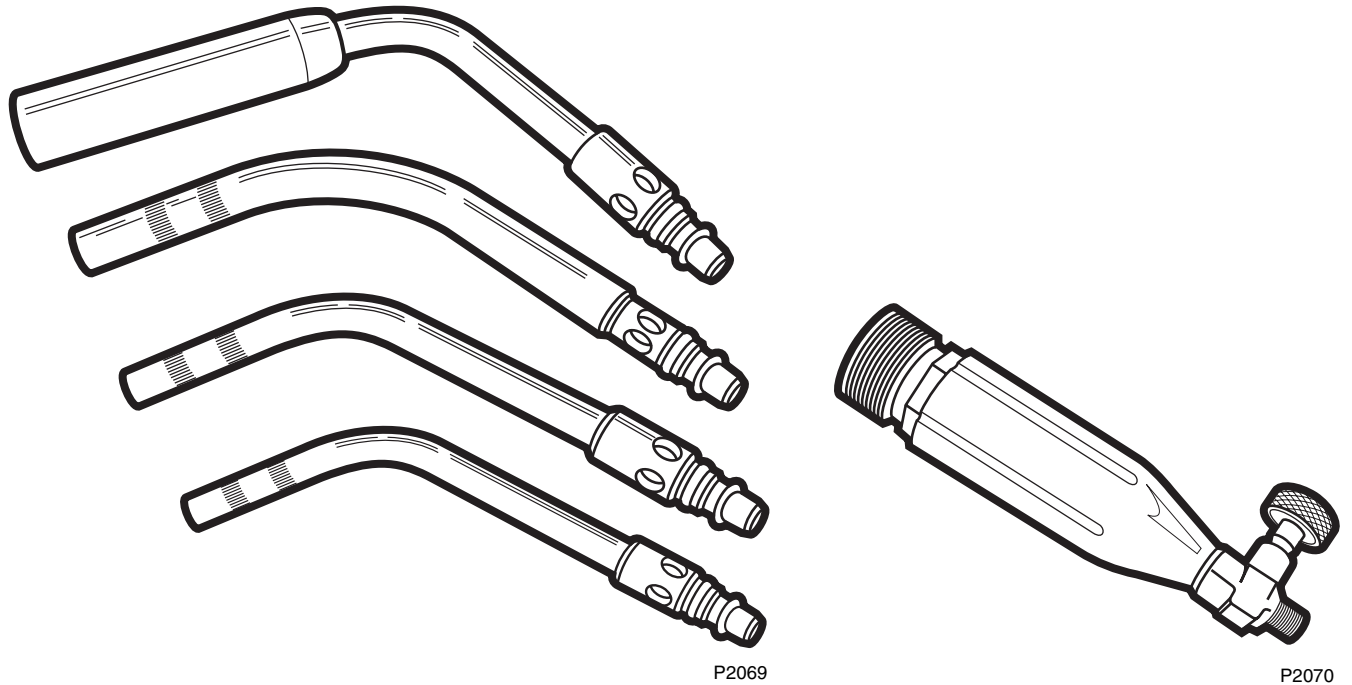

Specifications and Ordering Information

Part No.	Description	Replaces Turbo Torch Model	Fuel	Pressure PSIG	Gas Flow CFH	Copper Tubing Size & Capacity	
						Soft Solder (in.)	Silver Braze (in.)
21702	POL #1 Quick Disconnect Torch Handle	G-4					
21703	QD-SJ-3A	A-8	Acetylene	13	7.2	up to 2	1/2 - 1
21704	QD-SJ-4A	A-14	Acetylene	13	12.8	2 - 4	1 - 2
21705	QD-SJ-5A	A-32	Acetylene	13	33.8	4 - 6	1 - 4
21706	QD-SJ-3LPG	T-3	FG-2*	32	1.5	1/4 - 1-1/2	1/4 - 1/2
21707	QD-SJ-4LPG	T-4	FG-2*	32	3.1	1/4 - 2-1/2	1/4 - 1-1/4
21708	QD-SJ-5LPG	T-5	FG-2*	32	8.0	1 - 4	1/2 - 2
21709	QD-SJ-6LPG	T-6	FG-2*	32	16.2	1 - 6	3/4 - 4

*These tips can also be used with Propane and MAPP Gas (refer to instruction literature for appropriate pressures and flows for these gases). TurboTorch® is a registered trade name of Thermadyne.

TOOLS & SUPPLIES

Tanks and Carriers

- “R” Oxygen Tank holds 20 cu. ft. – new, empty
- “MC” Acetylene Tank holds 10 cu. ft. – new, empty
- Kangaroo Kart is a strong, lightweight polypropylene carrier for an MC acetylene tank and an R oxygen tank. Includes handy accessory compartment.

Ordering Information

“R” Oxygen Tank	22457
“MC” Acetylene Tank	22456
Kangaroo Kart	791F80
Nitrogen Cylinder Stand	88F82

Single Flint Lighter

- Specially hardened file surface – over one square inch
- Fat spark – flint strikes file at angle
- Quick ignition – protection cup forms gas-collection pocket
- File turns automatically – equalizes wear
- Easily replaceable flints
- Individually blister-packed

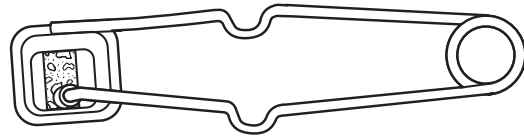

P4345

Ordering Information

Description	Part No.
Single Flint Lighter Heavy-Duty Model (Box of 10)	790F34

TOOLS & SUPPLIES

PREST-O-LITE® WELDING AND CUTTING OUTFITS

The New Sabre “V” Series Light Duty Welding and Cutting Outfits Interchangeable with Uniweld® and TurboTorch®.

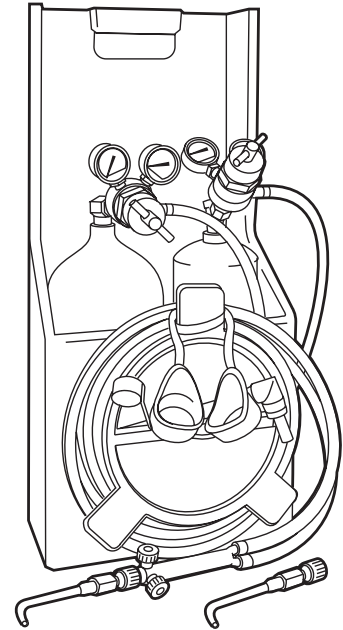

Welding Kit

Welding Kit	22552
QJ28 Welding Handle	
QWJ-2 Light Duty #2 Welding Nozzle	
QWJ-4 Light Duty #4 Welding Nozzle	
Oxygen Regulator R-22-75-540A	22254
Acetylene Regulator R-22-15-200A “MC”	22255
Twin Hose A-A 12-1/2 ft. A-A	591F72
Tote	791F80
Striker	790F34
Goggles	17862

Welding Kit With Tanks

Welding Kit with Tanks	22553
Oxygen Tank “R”, 20 Cu. Ft.	22457
Acetylene Tank “MC”, 10 Cu. Ft.	22456

TOOLS & SUPPLIES

NITROGEN PURGE & BLOW GUN KITS

NPK-40TS (22545)

- 40 cu. ft. tank, refillable, empty
- 6 ft / 1/8m hose
- OSHA rated blow gun
- Regulator, R-36-500-580
- Carrying stand
- Multiple uses: purges, blows, leak tests

NPK-40S (22546)

- 6 ft / 1/8m hose
- OSHA rated blow gun
- Regulator, R-36-500-580
- Carrying stand
- Multiple uses: purges, blows, leak tests

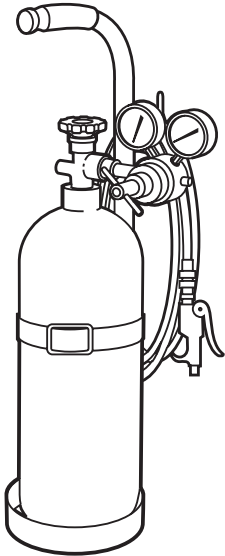

P2005

Nitrogen Purge Kit

Model No.	Part No.	Description
NPA-S	88F82	40 cu. ft. Carrying Stand
NPA-T	22544	40 cu. ft. Nitrogen Cylinder
NPA-G	22542	Blow Gun
NPA-H	22543	Charging Hose 6 ft
NPA-GH	22548	Blow Gun and Hose Assembly
NPA-GHR	22547	Blow Gun, Hose Assy. & Regulator

TOOLS & SUPPLIES

AIR FUEL OUTFITS

4-in-1 Outfit with Soft Flame Tips

For all purpose soldering, heating and brazing

- Meets most industrial demands
- B tank and MC tank models available
- Interchangeable tips – for proper flame size and heat
- Change tips in seconds – no tools necessary; tips lock in any working position
- Common torch handle – provides equivalent of five outfits
- Adjustable pressure regulator for steady gas delivery and stable flames

Description	Part No.
Prest-O-Lite 4-in-1 Outfit "B"	30X63
Prest-O-Lite 4-in-1 Outfit "MC"	30X64
Outfits Contain	Part No.
403 Torch Handle	02X93
#1A Soft Flame Brazing Tip	638948
#3 Soft Flame Brazing Tip	10X23
#4 Soft Flame Brazing Tip	10X24
#5 Soft Flame Brazing Tip	10X25
R-411 "B" Regulator or	04X36
R-411 "MC" Regulator	04X37
Hose 12-1/2 ft. x 3/16 in. A-A	501F12

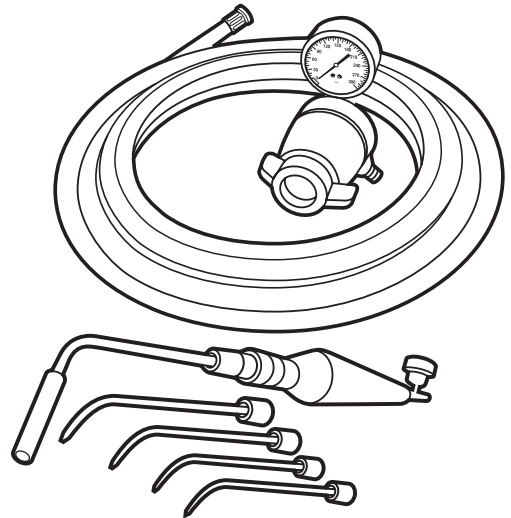

General Purpose Air-Acetylene Outfits with Soft Flame Tip

For sweat-type fittings, heating and brazing

- Ideal for copper, brass, steel and wrought iron pipe with solder-type fittings
- Precision flame control – for joints near a wall, against each other and in hard-to-reach places
- Instant heat – 4000° F, without pumping or priming
- Convenient – small, light, easy to handle and always ready to use
- Efficient – ample range for run-of-shop work; unaffected by drafts, wind and rain
- B tank and MC tank models available
- Adjustable pressure regulator with contents gauge and delivery pressure indicators on pressure adjustment knob

Description	Part No.
Prest-O-Lite General Purpose Outfit "B"	30X37
Prest-O-Lite General Purpose Outfit "MC"	30X38
General Purpose Outfits contain	Part No.
403 Torch Handle	02X93
#4 Soft Flame Brazing Tip	10X24
R-411 "B" Regulator or	04X36
R-411 "MC" Regulator	04X37
Hose 12-1/2 ft. x 3/16 in. A-A	501F12

P2071