

The M847B is a two position, 24 volt spring return damper operator designed to operate directly driven zone dampers, used to control air flow in ducts. The motor can be driven open using any 24 volt rated two position switch - eg. a wall switch or a thermostat subbase switch.

Specifications

Electrical Rating: 24 Vac 60 Hz 0.32 Amp.

Electrical Connection: 1 metre cable attached.

Nominal Angular Rotation: 90°

Torque: Min. 340 mNm (milli newton meter) [48 in.oz.] output torque available when motor is energized and device is at the spring returned position.

Nominal Motor Timing: (@25°C ambient)

Energized at rated load, 24 Vac power source - 30 seconds.

De-energized (spring return) - 20 seconds.

Ambient Temperature Rating: 5 to 60°C (+40 to 140°F)

Finish: zinc plated steel.

Direction of Shaft Rotation: clockwise, when energized and viewed from the base or shaft end.

Mounting Means: direct connection to damper shaft.

Mounting Position: Multi-prise.

Dimensions: See Figure 1.

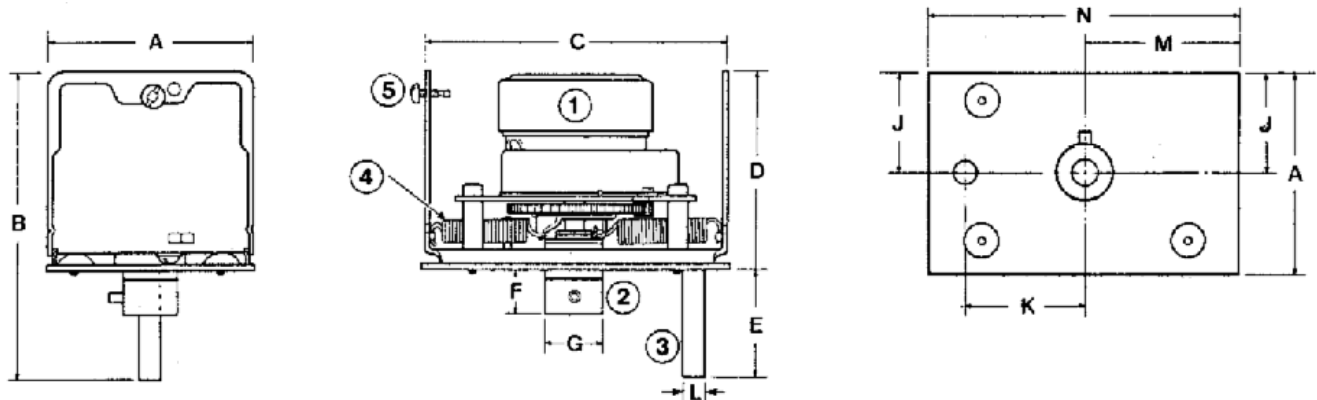
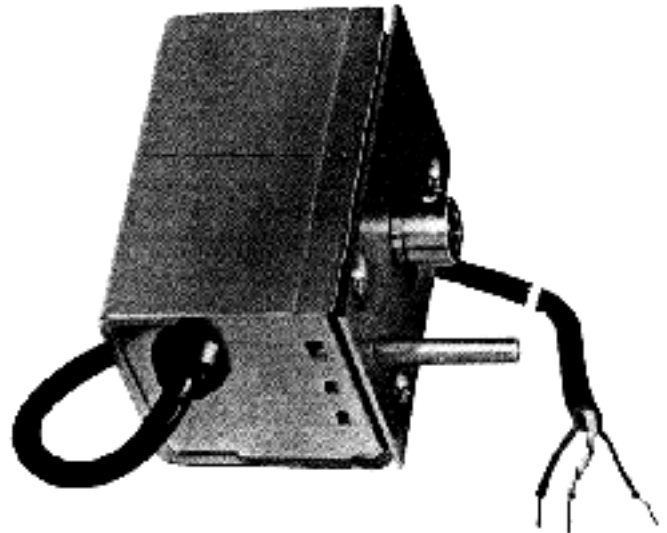

LEGEND

- | | |
|-------------------------|-------------------|
| 1 - Driving Motor | 4 - Return Spring |
| 2 - Connection Coupling | 5 - Device Case |
| 3 - Anti-rotation Shaft | |

Nominal Device Dimensions

	A	B	C	D	E	F	G	H	J	K	L	M	N
mm	60	88	85	56	31.5	13	16	6.4	28	33.5	8.2	45	89
in	2-3/8	3-1/2	3-3/8	2-7/32	1-1/4	1/2	5/8	1/4	1-1/8	1-5/16	21/64	1-49/64	3-1/2

Fig. 1 - Dimensional Details

Installation and Checkout

WARNING

- DO NOT attempt to simulate operation of the operator by rotating the connection coupling, or the damper shaft when it is connected to the operator.
- Abuse of this nature can result in stripping the gears in the drive train of the operator.

MOUNTING

The M847B can be mounted directly to the protruding damper shaft using the sleeve attached to the operator output shaft. Drill the prescribed hole directly below the damper shaft opening to accept the anti-rotation shaft protruding from the base of the motor. The length of the damper shaft to which

M847B

Installation and Checkout

MOUNTING (continue)

the connection coupling is attached is such as firmly hold the operator in a position to adequately engage the anti-rotation pin in the warm air duct. See Figure 1. for the critical dimensions.

WIRING

See Figure 2. for typical wiring hookups for the M847B.

CAUTION

1. Disconnect power supply before beginning installation and wiring the control to prevent electrical shock and equipment damage.
2. Installer must be a trained, experienced service technician.
3. All wiring must comply with local electrical codes, ordinances, and regulations.

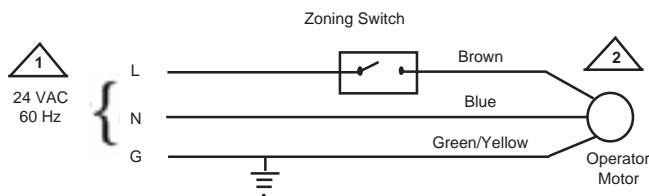

 1 PROVIDE DISCONNECT MEANS AND OVERLOAD PROTECTION AS REQUIRED.

 2 NOMINAL CURRENT 0.32 AMP

Fig. 2 - Typical M847B Hookup

CHECKOUT

When energized verify that the operator connection coupling rotates in a clockwise direction (as viewed from the operator base end) and that the damper shaft turns with the coupling. If a saw cut is put in the opposite end of the damper shaft, aligned with the position of the damper on the shaft, the actual rotation of the operator - and the damper - can be readily checked.

When de-energized the motor should rotate damper in reverse direction by means of the integral return springs. In the satisfied or de-energized position, the damper blade should be fully closed or in the vertical position when the operator is mounted on the side of a horizontal duct.

If the motor does not operate smoothly and without hesitation throughout the entire opening and closing stroke, examine the damper and the shaft, for free rotation within the duct. There should be at least a 1/4" clearance between all sides of the damper and the duct into which it is installed.