

3 terminal panel

Fig. 1

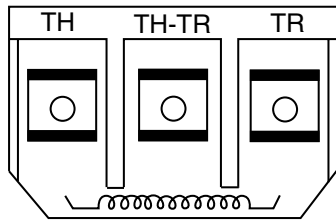

Some models have screw terminals instead of spade terminals shown

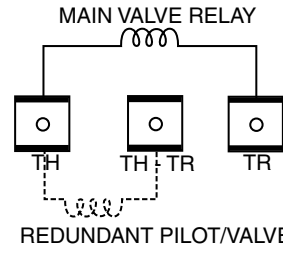

Some models may not have redundant valve

Milivolt 3 Terminal Panel

Fig. 2

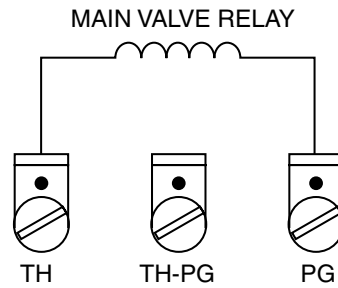
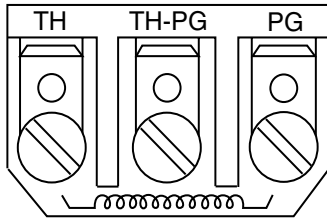

Fig.3

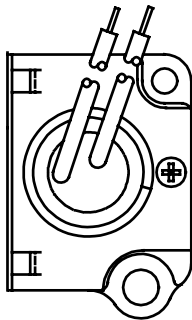
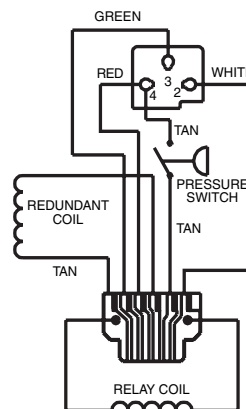
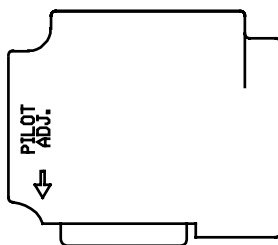

Fig. 4



TECHNICAL HELP

4 terminal panel

Fig. 5

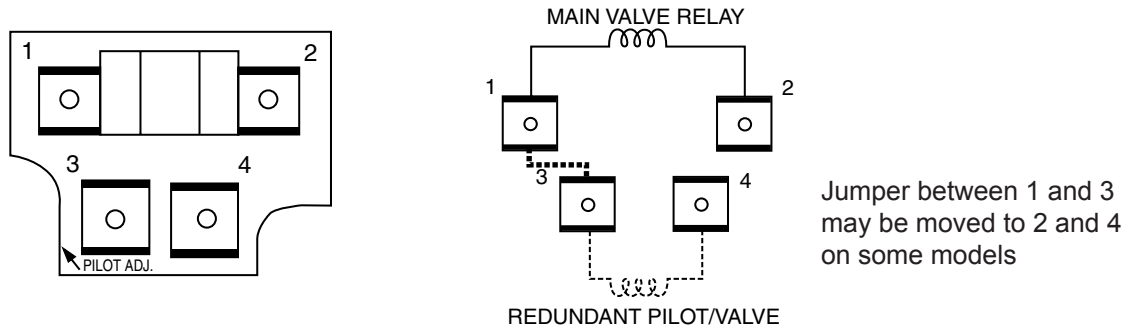

Bi-metal two stage

Fig. 6A

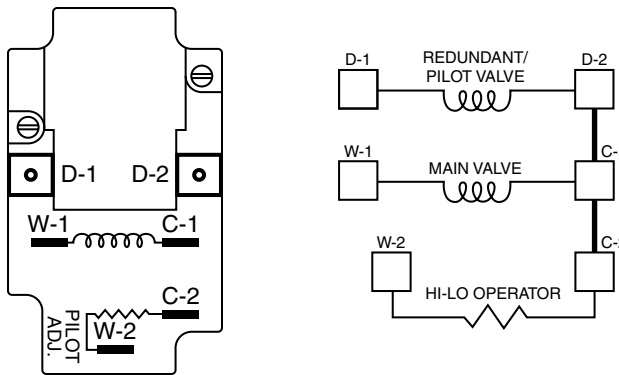

Bi-metal two stage

Fig. 6B

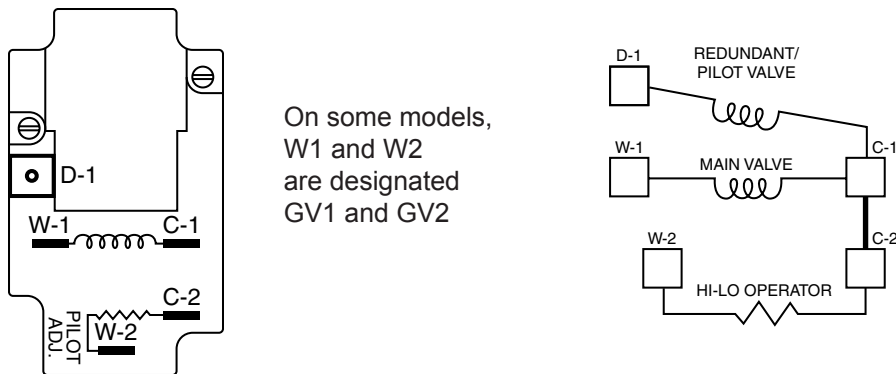

Cycle pilot Plug-in

Fig. 7

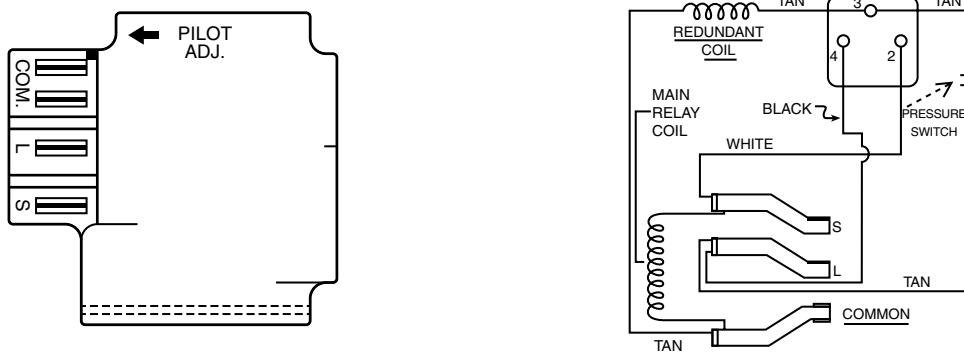

Cycle pilot with 4 terminal panel

Fig. 8

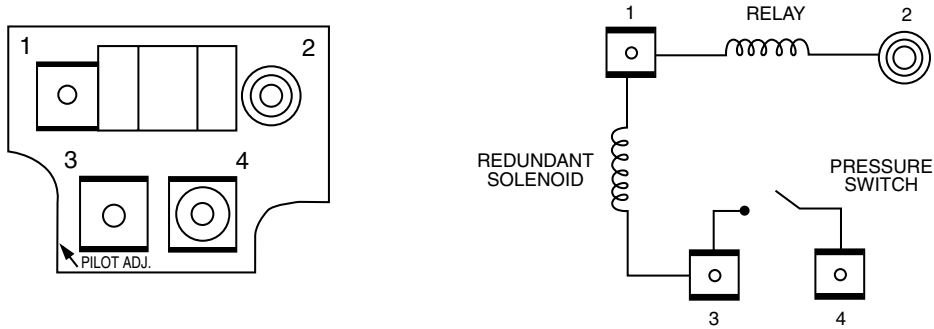

Relay two stage

Fig. 9

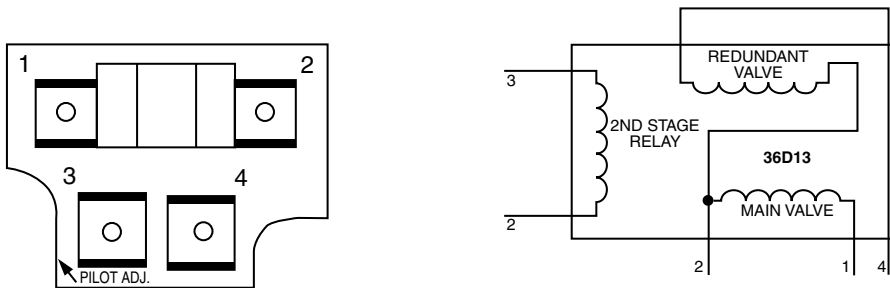

2 terminal panel

Fig.10

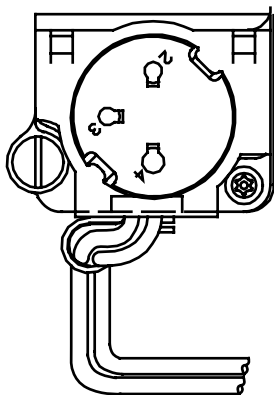
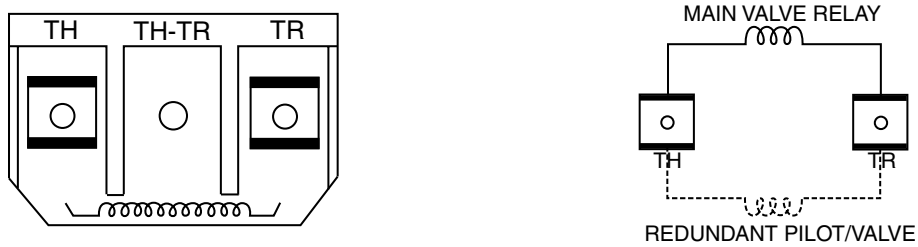
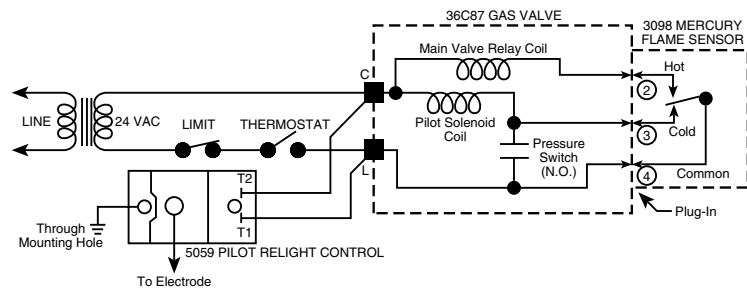

Fig.11



TECHNICAL HELP

Fig 12

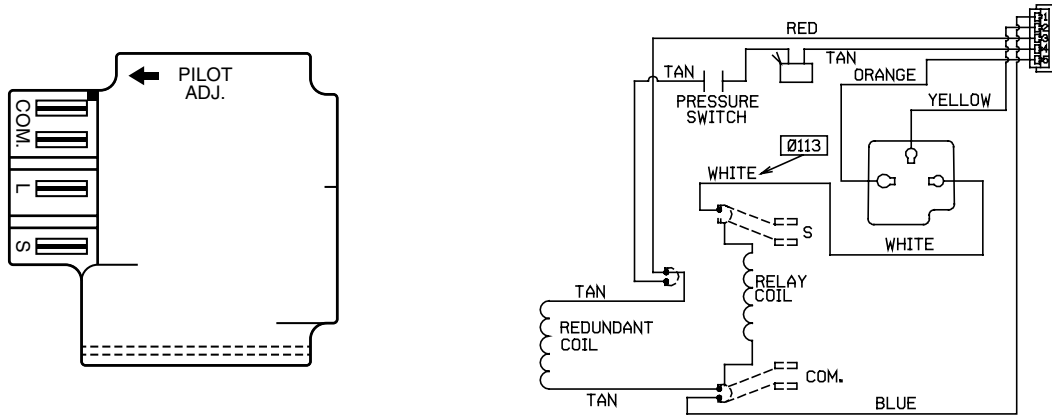

Fig 13

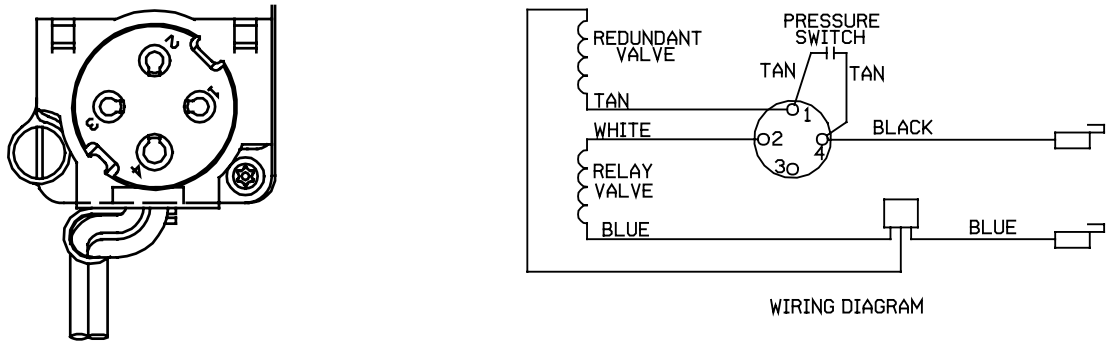

Fig 14

