

Introduction

Our strut support system is designed with many time-saving features. They are fully adjustable and reusable, with a complete line of channels, fittings and accessories for multi-purpose applications.

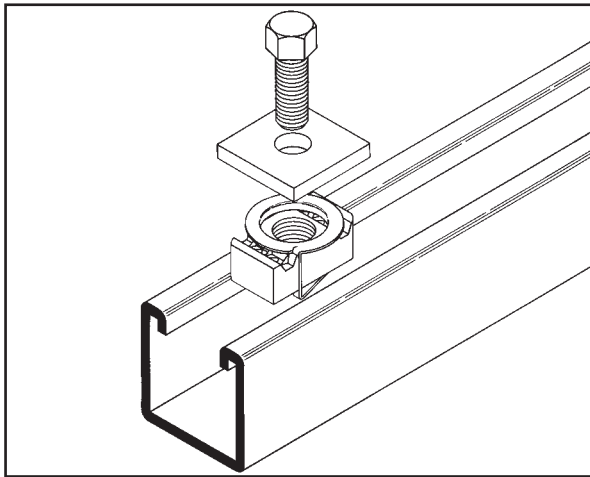

- No Welding
- No Drilling
- Use Your Imagination

The strut system installs quickly, with no need for special tools. All you need is a wrench and hacksaw.

Channels and parts can be taken apart for reuse as quickly as they were assembled, yet help provide the strength of welded construction. This eliminates welding and drilling which can have substantial savings in time and labor.

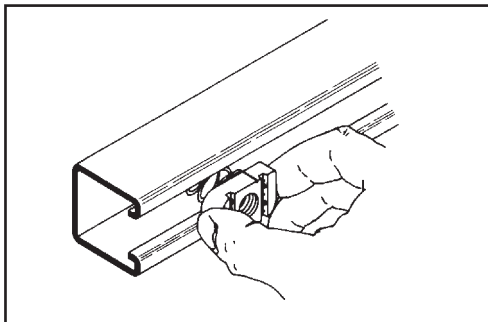

1. Channel nut may be inserted anywhere along continuous slot. Designed for easy insertion and self-alignment.

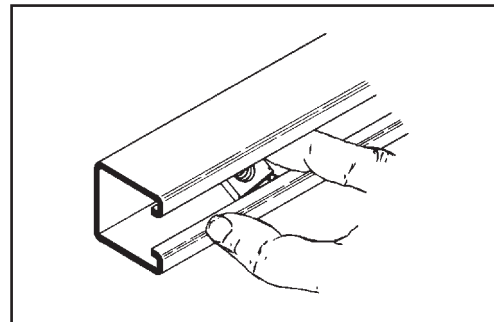

2. A 90° turn aligns channel nut grooves with inturned lips of the channel.

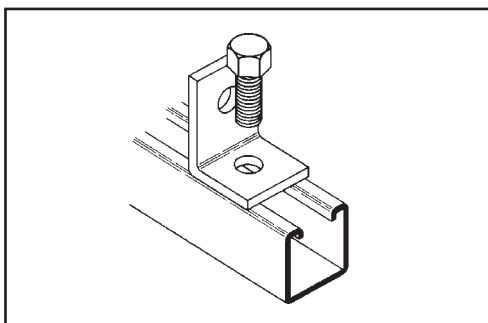

3. Position fitting over channel nut and insert bolt to start any connection.

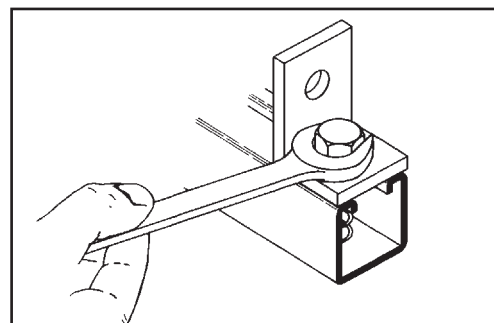

4. With the twist of a wrench, channel nut locks its teeth firmly against inturned lips.

Our strut system provides an economical solution for electrical, mechanical and industrial supports with an unlimited variety of applications in the construction industry.

Electrical Applications

- Lighting Fixture Supports
- Raceway Systems
- Trapeze Hangers
- Pipe & Conduit Supports
- Cable Tray Supports
- Beam Adjustments

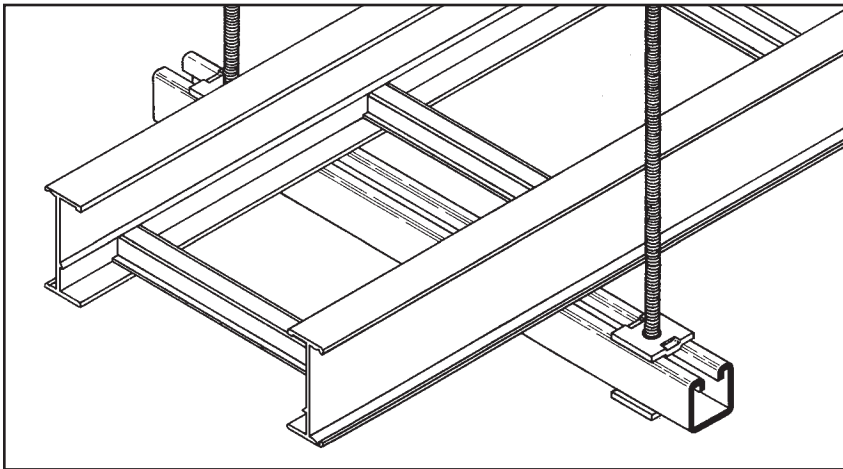
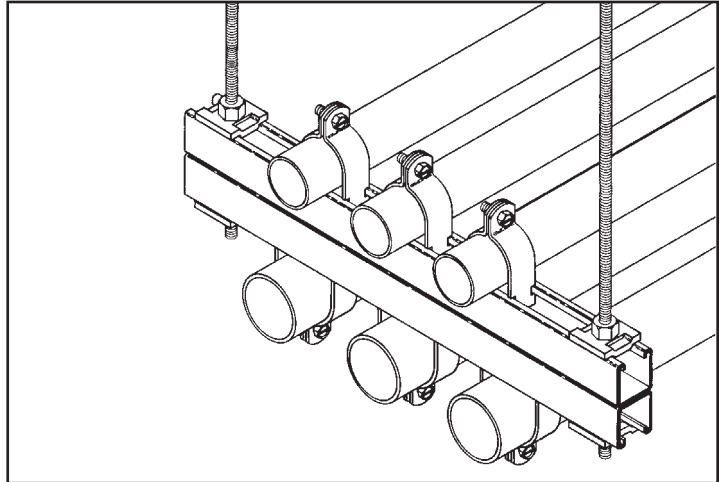

Mechanical Applications

- Piping Racks
- Tunnel Pipe Stanchions
- Concrete Inserts
- Beam Attachments
- Pipe Risers

Industrial Applications

- Racks and Shelving
- Partitions
- Production Line Supports
- Trolley Systems
- Wall Framing

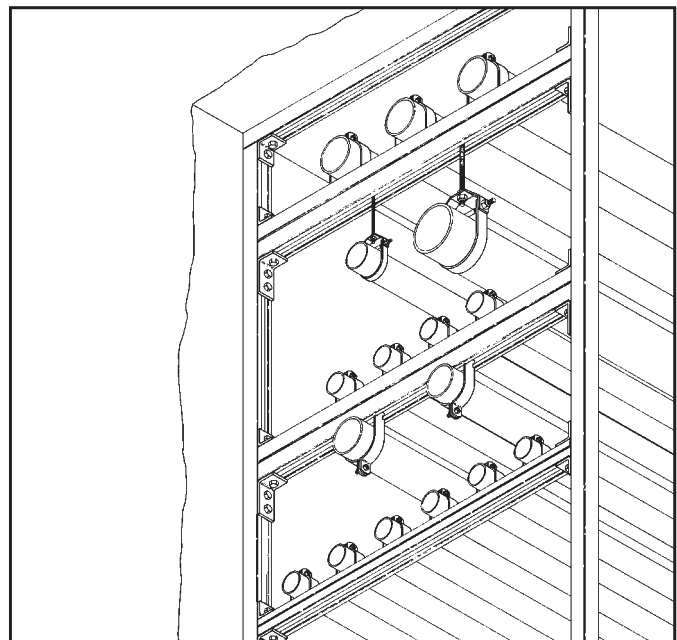

Technical Data

MATERIALS

Carbon Steel

Channels made from high-quality carbon steel are continuously roll formed to precise dimensions. By cold working the steel mechanical properties are increased, allowing lightweight structures to carry the required load. Corrosion resistance of carbon steel varies widely with coating and alloy. See "Finishes" for more detailed information.

Stainless Steel

Stainless steel channel is available in AISI Type 304 or 316 material. Both are non-magnetic and belong to the austenitic stainless steels group, based on alloy content and crystallographic structure. Like carbon steel, stainless steel exhibits increased strength when cold worked by roll-forming.

Several conditions make the use of stainless steel ideal. These include reducing long term maintenance costs, high ambient temperatures, appearance, and stable structural properties such as yield strength, and high creep strength.

Type 304 resists most organic chemicals, dyestuffs and a wide variety of inorganic chemicals at elevated or cryogenic temperatures. Type 316 contains slightly more nickel and adds molybdenum to give it better corrosion resistance in chloride and sulfuric acid environments. For more information concerning the differences between types 304 and 316, visit www.cooperblinc.com/contactus.

Aluminum

Standard aluminum channel is extruded from aluminum alloy 6063-T6. Strut fittings are made from aluminum alloy 5052-H32.

The high strength to weight ratio of channel made of aluminum helps greatly reduce the overall cost of installation through ease of handling and field cutting.

Aluminum owes its excellent corrosion resistance to its ability to form an aluminum oxide film that immediately reforms when scratched or cut. In most outdoor applications, aluminum has excellent resistance to "weathering". The resistance to chemicals, indoor or outdoor, can best be determined by tests conducted by the user with exposure to the specific conditions for which it is intended. The corrosion resistance of aluminum to some commonly known chemicals is shown in the Corrosion Chart. For further information, contact us or the Aluminum Association.

Fiberglass

We offer two fire retardant (FR) resins for strut systems, polyester and vinyl ester. Both resins are ideal for corrosive environments or nonconductive applications with moderate strength requirements. Some common types of environments where Vinyl Ester Resins are recommended, that Poly Esters are not, are paper mills, most any metal plating operation and any condition with

concentrated levels of Chlorine, [Cl⁻]. Please consult our fiberglass corrosion resistance charts on pg. 183 for specific chemical recommendation data.

Unlike other base materials depicted in this catalog, fiberglass exhibits unique physical property changes when operating in elevated temperature conditions that are a fraction of increase compared to steel or aluminum. Thus, it is advised against using fiberglass in temperatures greater than 200° F.

Please refer to the "Corrosion Resistance Guide" below for specific applications.

The fiberglass strut systems are manufactured from glass fiber-reinforced plastic shapes that meet ASTM E-84, Class 1 Flame Rating and self-extinguishing requirements of ASTM D-635. A surface veil is applied during pultrusion to insure a resin-rich surface and ultraviolet resistance.

While polyester is sufficient for most uses, vinyl ester is suitable for a broader range of environments.

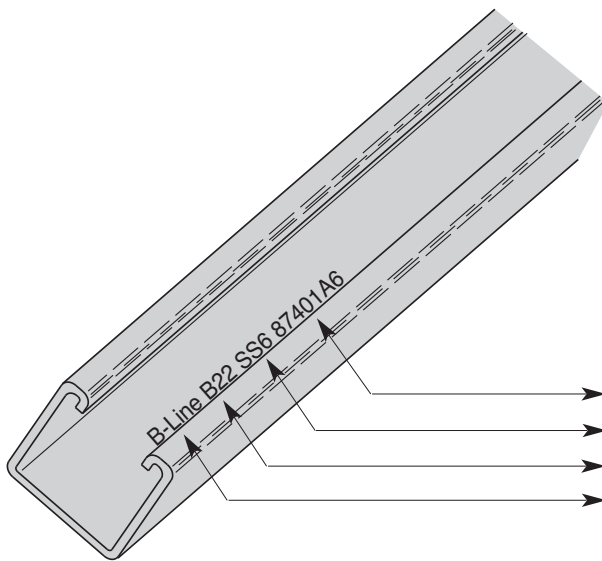

B-Line Steel Strut is stamped with:

- Traceable to the steel's origin
- Material/Finish
- B-Line part number designation
- Company Name

FINISHES

Zinc Coatings

Zinc protects steel in two ways. First it protects the steel as a coating and second as a sacrificial anode to repair bare areas such as cut edges, scratches, and gouges. The corrosion protection of zinc is directly related to its thickness and the environment. This means a .2 mil coating will last twice as long as a .1 mil coating in the same environment.

Galvanizing also protects cut and drilled edges.

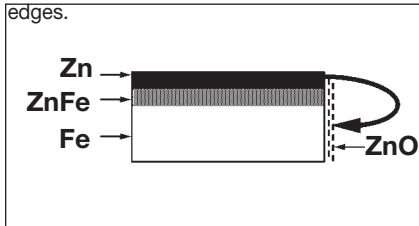

Electrogalvanized Zinc

Electrogalvanized Zinc (also known as zinc plated or electroplated) is the process by which a coating of zinc is deposited on the steel by electrolysis from a bath of zinc salts.

A rating of SC3, our standard, provides a minimum zinc coating thickness of .5 mils (excluding hardware, which is SC1 = .2 mils).

When exposed to air and moisture, zinc forms a tough, adherent, protective film consisting of a mixture of zinc oxides, hydroxides, and carbonates. This film is in itself a barrier coating which slows subsequent corrosive attack on the zinc. This coating is usually recommended for indoor use in relatively dry areas, as it provides ninety-six hours protection in salt spray testing per ASTM B117.

Chromium/ Zinc

Chromium/ Zinc is a corrosion resistant composition, which was developed to protect fasteners and small bulk items for automotive use. The coating applications have since been extended to larger parts and other markets.

Chromium/Zinc composition is an aqueous coating dispersion containing chromium, proprietary organics, and zinc flake.

This finish provides 500 hours protection in salt spray testing per ASTM B117.

Pre-Galvanized Zinc

(Mill galvanized, hot dip mill galvanized or continuous hot dip galvanized) Pre-galvanized steel is produced by coating coils of sheet steel with zinc by continuously rolling the material through molten zinc at the mills. This is also known as mill galvanized or hot dip mill galvanized. These coils are then slit to size and fabricated by roll forming, shearing, punching, or forming to produce our pre-galvanized strut products.

The G90 specification calls for a coating of .90 ounces of zinc per square foot of steel. This results in a coating of .45 ounces per square foot on each side of the sheet. This is important when comparing this finish to hot dip galvanized after fabrication.

During fabrication, cut edges and welded areas are not normally zinc coated; however, the zinc near the uncoated metal becomes a sacrificial anode to protect the bare areas after a short period of time.

Hot Dip Galvanized After Fabrication (Hot dip galvanized or batch hot dip galvanized)

Hot dip galvanized strut products are fabricated from steel and then completely immersed in a bath of molten zinc. A metallic bond occurs resulting in a zinc coating that completely coats all surfaces, including edges and welds.

Another advantage of this method is coating thickness. Strut products that are hot dip galvanized after fabrication have a minimum thickness of 1.50 ounces per square foot on each side, or a total 3.0 ounces per square foot of steel, according to ASTM A123.

The zinc thickness is controlled by the amount of time each part is immersed in the molten zinc bath as well as the speed at which it is removed. The term "double dipping" refers to parts too large to fit into the galvanizing kettle and, therefore, must be dipped one end at a time. It does not refer to extra coating thickness.

The layer of zinc which bonds to steel provides a dual protection against corrosion. It protects first as an overall barrier coating. If this coating happens to be scratched or gouged, zinc's secondary defense is called upon to protect the steel by galvanic action.

Hot-Dip Galvanized After Fabrication is recommended for prolonged outdoor exposure and will usually protect steel for 20 years or more in most atmospheric environments and in many industrial environments. For best results, a zinc rich paint (available from B-Line) should be applied to field cuts. The zinc rich paint will provide immediate protection for these areas and eliminate the short time period for galvanic action to "heal" the damaged coating.

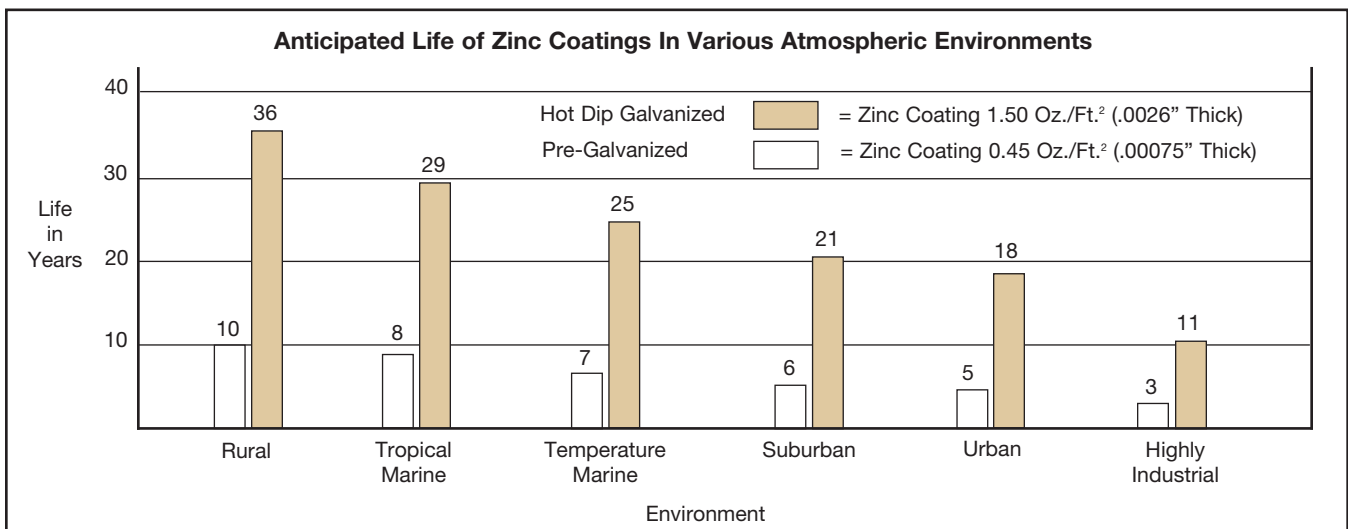

Technical Data

Technical Data

DURA-GREEN™ and DURA-COPPER™ Epoxy Coatings

DURA-GREEN and DURA-COPPER epoxy coatings are water borne epoxy coatings applied to B-Line products by a precisely controlled cathodic electro-deposition process. This process is accomplished using a conveyor to transport channel and fittings through several cleaning, phosphating and application stages prior to being baked (See diagram below).

This custom-designed paint system is used for painting all channels, channel combinations, slotted angle, and fittings.

Samples are selected on a routine basis for Salt Spray (fog) testing to verify the quality of the finish. These tests are performed in accordance with ASTM B117 and evaluated and related according to ASTM D1654 (Tables 1 & 2).

The DURA-GREEN and DURA-COPPER Epoxy coatings have been tested and listed by Underwriters Laboratories in accordance with "Standard for Surface Metal Raceway and Fittings, UL5" and

"Standard for Pipe Hanger Equipment for Fire Protection Service, UL203".

Due to DURA-GREEN's organically based composition, it seats itself into porous surfaces more completely and efficiently than zinc coatings. As these porous caverns are filled along the material profile, the outer finished surface demonstrates an increased smooth uniform plane which produces considerably less off-gasing when tested.

DURA-GREEN channel meets or exceeds 100 level clean room standards. This was confirmed by testing the channel in accordance with Boeing (PCL) Standards, which are more stringent and complete than ASTM E595-93. DURA-GREEN was found to be a superior finish, due in part to its proven application process.

PVC Coating

Another of the corrosion resistant coatings offered by B-Line is PVC (polyvinyl chloride), applied over steel or aluminum channel and fittings. The PVC coating process begins by cleaning the product

thoroughly. A bonding coat is applied to the part and then preheated to a temperature above the melting point of the coating powder. The product is then passed through a fluidized bed of vinyl plastic powder where the powder particles melt, adhere and flow out to form a smooth continuous coating. The thickness is controlled by the base metal temperature and the immersion time in the bed. It is then post-heated to complete the fusion of the outer surfaces.

The standard coating thickness of B-Line's PVC coated products is 15 mils (.380 mm), plus or minus 5 mils (.125 mm). Since the chemistry, not the thickness of vinyl plastic PVC determines longevity, a coating of 10 to 20 mils (.250 to .500 mm) is more than adequate. If the corrosive conditions are such that the plasticizers are leached out, a thicker coating will do little to extend the life of a coated product.

For certain environments, a plastisol dipped PVC coating is available on request.

PVC coating depends totally on the concept of encapsulation attached to the base metal by a bonding agent. If any hole or discontinuity occurs, the corrosive action can undercut the base metal to a point where all that remains is the PVC.

In the event of field cuts or any other damage to the coating, a liquid PVC patch, available from B-Line, must be applied to maintain the integrity of the coating. After the installation is complete, a thorough inspection should be performed to assure the absence of voids, pinholes, or cuts.

SALT SPRAY TEST RESULTS

Type of Finish	Unscribed 5% Failure (1)	Scribed 1/8" (3.2) Creepage from Scribe (1)
B-Line DURA-GREEN Epoxy	1000 Hours	312 Hours
Mill Galv. (Pre-Galv.) G90	192 Hours	288 Hours
Perma-Green	438 Hours	231 Hours
Zinc Chromate	36 Hours	96 Hours
Industry Green (Range)	10 to 36 Hours	4 to 30 Hours

(1) All salt spray (fog) tests conducted in accordance with ASTM B117 and evaluated and rated according to ASTM D1654 Tables 1 & 2. Tests are performed and certified by an independent testing laboratory.

DURA-GREEN™/DURA-COPPER™ EPOXY COATING PROCESS

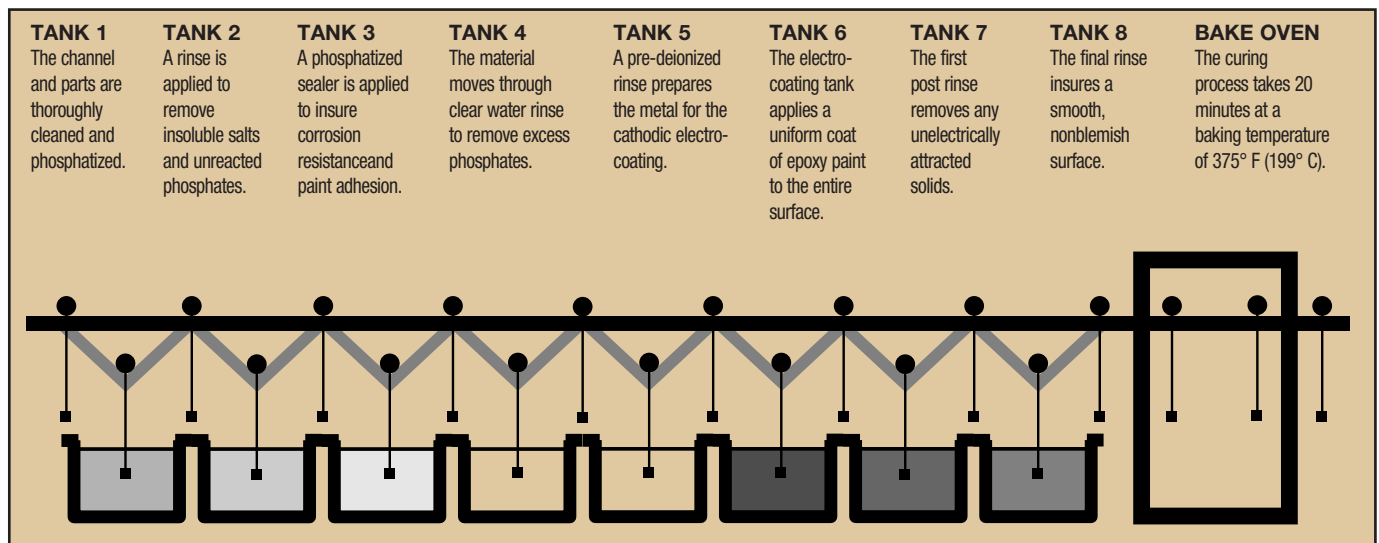

WELDING

The welding procedures used in the fabrication of our steel products are in accordance with American Welding Society Standards. To achieve the highest quality in our manufacturing processes, our welders follow standards set by AWS Code.

Spot Welding

Spot welded back-to-back channel is manufactured using a modern DC powered resistance welder controlled by a microprocessor. This produces a series of spot welds with speed and consistency. Consistency is one of the most important advantages in specifying back-to-back channel. Variables such as

weld sequence, speed and duration are carefully controlled and monitored by a sophisticated electronic control system. A statistical quality control program, combining destructive and non-destructive testing, is used to ensure high quality welds.

MIG Welding

MIG welded, more properly called gas metal arc welded (GMAW) combination channels and fittings, are produced when physical dimensions or certain combinations require a weld process other than automatic spot welding. The same quality control requirements are imposed on MIG welded and spot-welded products.

Quality Assurance

Our Quality Assurance Program has been developed and implemented for compliance with ISO9001:2008. We also complies with various industry standards and specifications. We have extensive experience in supplying metal framing components for the nuclear power generating industry, and upon request can provide products in compliance with 10CFR50 Appendix B, NQA-1 and 10CFR21. For more information on our quality capability please visit www.cooperblineline.com/nuclear.

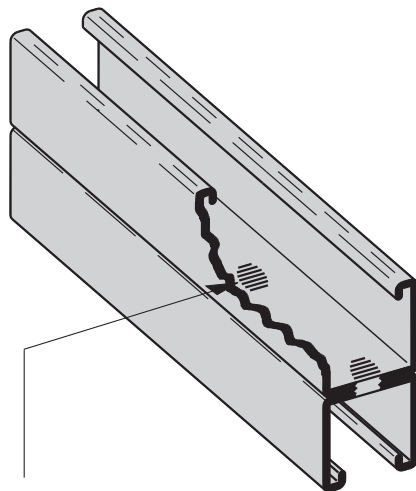

Spot Weld

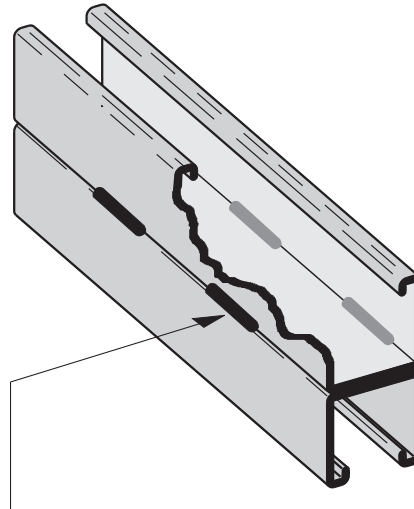

MIG Weld

CORROSION

All metal surfaces are affected by corrosion. Depending on the physical properties of the metal and the environment to which it is exposed, chemical or electromechanical corrosion may occur.

Atmospheric Corrosion

Atmospheric corrosion occurs when metal is exposed to airborne liquids, solids or gases. Some sources of atmospheric corrosion are moisture, salt, dirt and sulphuric acid. This form of corrosion is typically more severe outdoors, especially near marine environments.

Chemical Corrosion

Chemical corrosion takes place when metal comes in direct contact with a corrosive solution. Some factors which affect the severity of chemical corrosion include: chemical concentration level, duration of contact, frequency of washing, and operating temperature.

Storage Corrosion

Wet storage stain (white rust) is caused by the entrapment of moisture between surfaces of closely packed and poorly ventilated material for an extended period. Wet storage stain is usually superficial, having no affect on the properties of the metal.

Light staining normally disappears with weathering. Medium to heavy buildup should be removed in order to allow the formation of normal protective film. Proper handling and storage will help to assure stain-free material. If product arrives wet, it should be unpacked and dried before storage. Dry material should be stored in a well ventilated "low moisture" environment to avoid condensation formation. Outdoor storage is undesirable, and should be avoided whenever possible.

Galvanic Corrosion

Galvanic corrosion occurs when two or more dissimilar metals are in contact in the presence of an electrolyte (ie. moisture). An electrolytic cell is created and the metals form an anode or a cathode depending on their relative position on the Galvanic Series Table. The anodic material will be the one to corrode. Anodic or cathodic characteristics of two dissimilar metals will depend on the type of each material. For example: If zinc and steel are in contact, the zinc acts as the anode and will corrode; the steel acts as the

GALVANIC SERIES IN SEA WATER

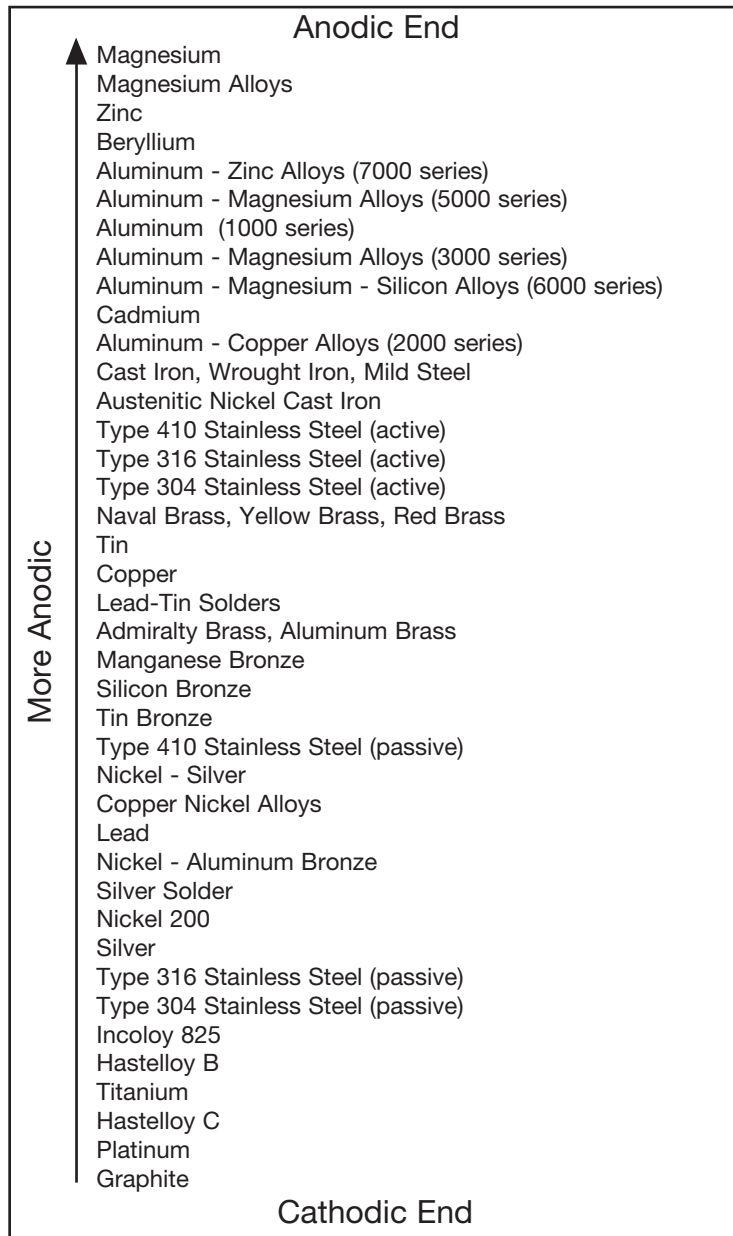

Metals in descending order of activity in the presence of an electrolyte.

cathode, and will be protected. If steel and copper are in contact, the steel is now the anode and will corrode. The rate at which galvanic corrosion occurs depends on several factors:

1. The relative position on the Galvanic Series Table - the further apart materials are in the Galvanic Series Table, the greater the potential for corrosion of the anodic material.

2. The amount and concentration of electrolyte present - an indoor, dry environment will have little or no galvanic corrosion compared to a wet atmosphere.

3. The relative size of the materials - a small amount of anodic material in contact with a large cathodic material will result in greater corrosion. Likewise, a large anode in contact with a small cathode will decrease the rate of attack.

Chemical	Aluminum	Dura-Green	PVC	Type 304 Stainless	Type 316 Stainless	Zinc Coated Steel
Acetic Acid 10%	R	NR	R	R	R	NR
Acetic Acid 2%	R	F	R	R	R	NR
Acetone	R	R	NR	R	R	R
Ammonium Hydroxide-Conc.	R	R	R	R	R	-
Ammonium Hydroxide 10%	F	R	R	R	R	-
Ammonium Hydroxide 2%	R	R	R	R	R	-
Benzene	R	R	NR	R	R	-
Bromine Water	NR	R	R	NR	NR	-
Butanol (Butyl Alcohol)	R	R	R	R	R	R
Carbon Disulfide	R	R	NR	R	R	-
Carbon Tetrachloride	F	R	F	R	R	-
Chlorine Water	R	R	R	NR	F	R
Cutting Oil	-	R	-	-	-	-
Diethanolamine	R	R	NR	-	-	NR
Ethanol	R	R	R	R	R	R
Ethyl Acetate	R	R	NR	-	-	R
Ethylene Dichloride	F	R	NR	-	-	R
Formaldehyde 20%	R	R	R	R	R	R
Gasoline	R	R	R	R	R	R
Glycerine	R	R	R	R	R	R
Household Detergent 10%	F	R	R	R	R	-
Hydrochloric Acid 40%	NR	NR	R	NR	NR	NR
Hydrochloric Acid 10%	NR	F	-	NR	NR	NR
Hydrochloric Acid 2%	NR	F	-	NR	NR	NR
Hydrogen Peroxide 30%	R	NR	R	R	R	-
Hydrogen Peroxide 3%	R	R	-	R	R	-
Hydrogen Sulfide (Gas)	R	R	R	F	R	-
JP-4 Jet Fuel	R	R	R	R	R	-
Lactic Acid 85%	F	R	R	NR	-	-
Latex	R	R	-	R	R	NR
Linseed Oil Fatty Acid	R	F	R	R	R	-
Methanol	R	R	R	R	R	R
Methyl Ethyl Ketone	R	R	NR	-	-	R
Methyl Isobutyl Ketone	R	R	NR	-	-	R
Mineral Spirits	R	R	-	-	-	-
Motor Oil-10W	R	R	R	R	R	R
Naphtha, VM&P	R	R	R	R	R	R
Nitric Acid 2%	F	NR	R	R	R	-
Perchloroethylene	R	R	-	-	-	NR
Petroleum Ether	-	R	-	R	R	R
Phenol 10%	R	R	NR	R	R	R
Phosphoric Acid 2%	F	NR	R	R	R	NR
Potassium Hydroxide 50%	NR	R	R	R	R	-
Potassium Hydroxide 10%	NR	R	R	R	R	-
Potassium Hydroxide 2%	NR	R	R	R	R	-
Sodium Chloride 25%	F	R	R	R	R	F
Sodium Hydroxide 50%	NR	R	R	R	R	NR
Sodium Hydroxide 10%	NR	R	R	R	R	F
Sodium Hydroxide 2%	NR	R	R	-	-	-
Sodium Hypochlorite-C1. 10%	F	R	R	-	-	-
Sodium Hypochlorite-C1. 6%	F	R	R	NR	R	-
Sulfuric Acid 2%	F	NR	R	NR	R	NR
Tall Oil Fatty Acid (Syfate 94)	R	R	R	-	-	-
Tannic Acid 50%	F	R	R	R	R	-
Water-Deionized	R	R	R	R	R	F
Water-Sea	F	F	R	R	R	F
Water-Tap	R	R	R	F	F	R
Xyol	R	R	NR	-	-	-

Technical Data

Fiberglass corrosion chart on page 183.

The corrosion data given in this table is for general comparison only.

The presence of contaminants and the effect of temperature in chemical environments can greatly affect the corrosion of any material.

B-Line strongly suggests that field service tests or simulated laboratory tests using actual environmental conditions be conducted in order to determine the proper materials and finishes to be selected.

R=Recommended

F=May be used under some conditions

NR=Not Recommended

-Information not available

Fittings

This section offers a full selection of fittings and accessories to complete our strut system. Fittings are made from hot rolled, pickled and oiled plate or strip steel in accordance with ASTM A1018 33,000 PSI min. yield, unless noted.

Dimensions

The following dimensions apply to all fittings except as noted:

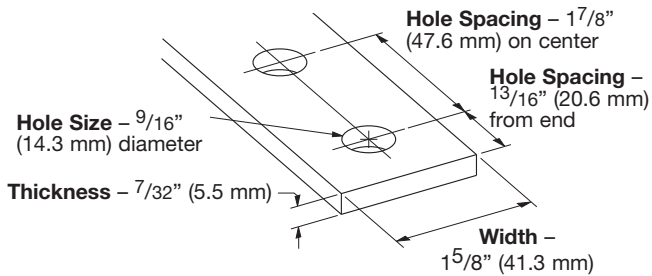

Materials & Finishes (Unless otherwise noted)

Finish Code	Finish	Specification
PLN	Plain	ASTM A1018 33,000 PSI min. yield
ZN	Electro-Plated Zinc	ASTM B633 SC3 Type III or ASTM A653
GRN	DURA-GREEN™	
HDG	Hot-Dipped Galvanized	ASTM A123
SS4	Stainless Steel Type 304	ASTM A240
SS6	Stainless Steel Type 316	ASTM A240
AL	Aluminum	ASTM B209

Note: A minimum order may apply on special material and finishes.

Load Data

The load data published includes safety factor of 2.5 when used with 12 ga. (2.6) channel (safety factor = ratio of ultimate load to the design load).

Use $\frac{1}{2}$ "-13 x $\frac{7}{8}$ " hex head cap screws and $\frac{1}{2}$ "-13 (N225 or TN225) channel nuts for the rated results.

Recommended Bolt Torque

Bolt Size	$\frac{1}{4}$ "-20	$\frac{5}{16}$ "-18	$\frac{3}{8}$ "-16	$\frac{1}{2}$ "-13
Foot/Lbs.	6	11	19	50
Nm	8	15	26	68

See chart on page 112 for setscrew torque.

Hardware

Nuts and bolts are not included with the fittings and must be ordered separately, unless noted.

Pre-Assembled Fittings

Some fittings are available with hex head cap screws and channel nuts pre-assembled. These fittings and finishes will be flagged using the following symbol.



Metric

Metric dimensions are shown in parentheses. Unless noted, all metric dimensions are in millimeters.



90° Angle Fittings

B420-378 ONE HOLE CORNER ANGLE

- Standard finishes: ZN, GRN
- Wt./C 60 Lbs. (27.2 kg)

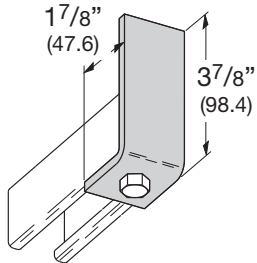

B420-578 ONE HOLE CORNER ANGLE

- Standard finishes: ZN, GRN
- Wt./C 85 Lbs. (38.5 kg)

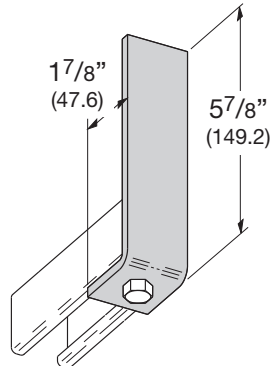

B420-778 ONE HOLE CORNER ANGLE

- Standard finishes: ZN, GRN
- Wt./C 107 Lbs. (48.5 kg)

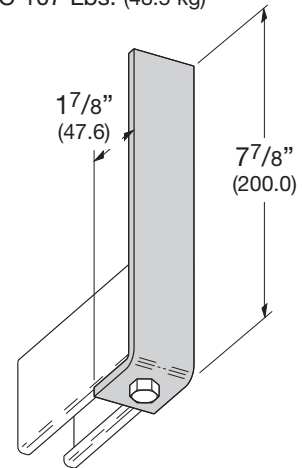

B420-978 ONE HOLE CORNER ANGLE

- Standard finishes: ZN, GRN
- Wt./C 129 Lbs. (58.5 kg)

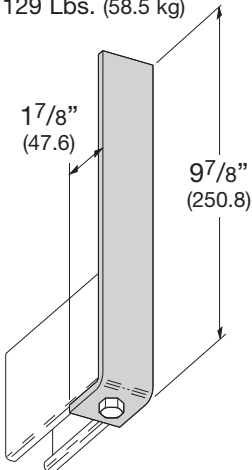

B101 TWO HOLE CORNER ANGLE

- Standard finishes: ZN, GRN, HDG, SS4, AL
- Wt./C 37 Lbs. (16.8 kg)

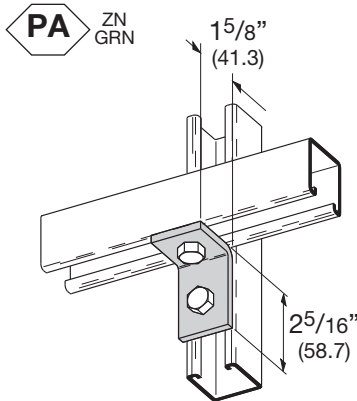

B230 TWO HOLE CORNER ANGLE

- Standard finishes: ZN, GRN, HDG, SS4, AL
- Wt./C 37 Lbs. (16.8 kg)

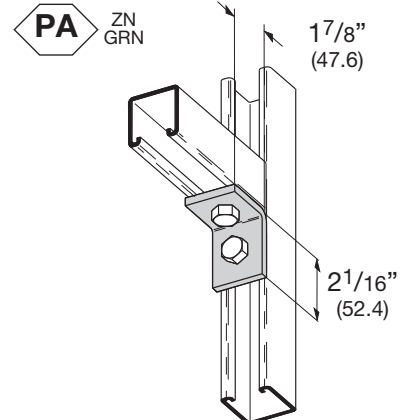

B231 TWO HOLE "NO-TWIST" CORNER ANGLE

- Standard finishes: ZN, GRN, HDG
- Wt./C 41 Lbs. (18.6 kg)

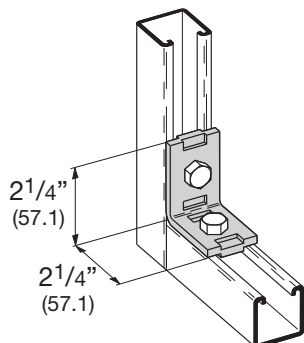

B359 TWO HOLE CORNER ANGLE

- Standard finishes: ZN, GRN
- Wt./C 48 Lbs. (21.8 kg)

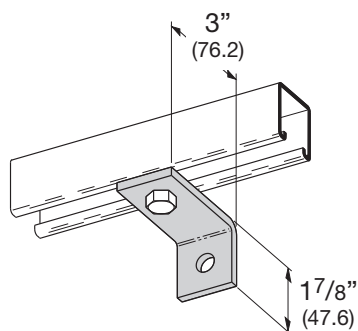

B360 TWO HOLE CORNER ANGLE

- Standard finishes: ZN, GRN
- Wt./C 53 Lbs. (24.0 kg)

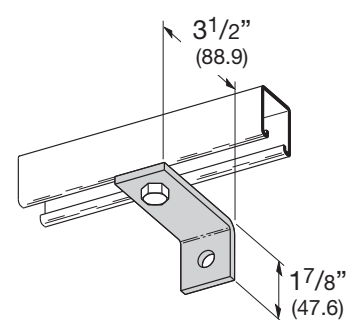

Strut Fittings

PA Preassembled fitting.

Reference page 72 for general fitting and standard finish specifications.