

# INSTALLATION AND SERVICE MANUAL

## power vented gas-fired unit heaters

### models PDP and BDP



All models approved for use in California by the CEC and in Massachusetts. Unit heater is certified for non-residential applications.

## FOR YOUR SAFETY

The use and storage of gasoline or other flammable vapors and liquids in open containers in the vicinity of this appliance is hazardous.

## WARNING

1. Improper installation, adjustment, alteration, service, or maintenance can cause property damage, injury, or death, and could cause exposure to substances which have been determined by various state agencies to cause cancer, birth defects, or other reproductive harm. Read the installation, operating, and maintenance instructions thoroughly before installing or servicing this equipment.
2. Do not locate ANY gas-fired units in areas where chlorinated, halogenated, or acidic vapors are present in the atmosphere. These substances can cause premature heat exchanger failure due to corrosion, which can cause property damage, serious injury, or death.

## IMPORTANT

The use of this manual is specifically intended for a qualified installation and service agency. All installation and service of these units must be performed by a qualified installation and service agency.

### Inspection on Arrival

1. Inspect unit upon arrival. In case of damage, report it immediately to transportation company and your local Modine sales representative.
2. Check rating plate on unit to verify that power supply meets available electric power at the point of installation.
3. Inspect unit upon arrival for conformance with description of product ordered (including specifications where applicable).

### Table of Contents

Inspection on Arrival	1
Special Precautions	2
SI (Metric) Conversion Factors	3
Before You Begin	3
Unit Location	4
Combustible Material and Service Clearances	4
Unit Mounting	5
Installation	6
Venting	6
Gas Connections	10
High-Altitude Accessory Kit	11
Electrical	13
Start-Up Procedure/Operation	15
Unit Components	18
Performance Data - General	19
Performance Data - Downturn Hoods	22
Dimensions	24
Service/Troubleshooting	26
Serial/Model Number Designations	29
Commercial Warranty	Back Cover

## FOR YOUR SAFETY

### WHAT TO DO IF YOU SMELL GAS:

1. Open windows.
2. Do not try to light any appliance.
3. Do not touch any electrical switch; do not use any phone in your building.
4. Extinguish any open flame.
5. Immediately call your gas supplier from a neighbor's phone. Follow the gas supplier's instructions. If you can not reach your gas supplier, call your fire department.

# SPECIAL PRECAUTIONS

## SPECIAL PRECAUTIONS

**THE INSTALLATION AND MAINTENANCE INSTRUCTIONS IN THIS MANUAL MUST BE FOLLOWED TO PROVIDE SAFE, EFFICIENT AND TROUBLE-FREE OPERATION. IN ADDITION, PARTICULAR CARE MUST BE EXERCISED REGARDING THE SPECIAL PRECAUTIONS LISTED BELOW. FAILURE TO PROPERLY ADDRESS THESE CRITICAL AREAS COULD RESULT IN PROPERTY DAMAGE OR LOSS, PERSONAL INJURY, OR DEATH. THESE INSTRUCTIONS ARE SUBJECT TO ANY MORE RESTRICTIVE LOCAL OR NATIONAL CODES.**

### HAZARD INTENSITY LEVELS

1. **DANGER:** Indicates an imminently hazardous situation which, if not avoided, WILL result in death or serious injury.
2. **WARNING:** Indicates a potentially hazardous situation which, if not avoided, COULD result in death or serious injury.
3. **CAUTION:** Indicates a potentially hazardous situation which, if not avoided, MAY result in minor or moderate injury.
4. **IMPORTANT:** Indicates a situation which, if not avoided, MAY result in a potential safety concern.

## DANGER

Appliances must not be installed where they may be exposed to a potentially explosive or flammable atmosphere.

## WARNING

1. Gas fired heating equipment must be vented - do not operate unvented.
2. A built-in power exhaust fan is provided - additional external power exhausters are not required or permitted.
3. If an existing heater is being replaced, it may be necessary to resize the venting systems. Improperly sized venting systems can result in vent gas leakage or the formation of condensate. Refer to the National Fuel Gas Code ANSI Z223.1 (NFPA 54) or CSA B149.1 – latest edition. Failure to follow these instructions can result in injury or death.
4. Under no circumstances should two sections of double wall vent pipe be joined together within one horizontal vent system due to the inability to verify complete seal of inner pipes.
5. All field gas piping must be pressure/leak tested prior to operation. Never use an open flame. Use a soap solution or equivalent for testing.
6. Gas pressure to appliance controls must never exceed 14" W.C. (1/2 psi).
7. To reduce the opportunity for condensation, the minimum sea level input to the appliance, as indicated on the serial plate, must not be less than 5% below the rated input, or 5% below the minimum rated input of dual rated units.
8. Disconnect power supply before making wiring connections to prevent electrical shock and equipment damage.
9. All appliances must be wired strictly in accordance with wiring diagram furnished with the appliance. Any wiring different from the wiring diagram could result in a hazard to persons and property.
10. Any original factory wiring that requires replacement must be replaced with wiring material having a temperature rating of at least 105°C.
11. Ensure that the supply voltage to the appliance, as indicated on the serial plate, is not 5% greater than the rated voltage.

## WARNING

12. When servicing or repairing this equipment, use only factory-approved service replacement parts. A complete replacements parts list may be obtained by contacting the factory. Refer to the rating plate on the appliance for complete appliance model number, serial number, and company address. Any substitution of parts or controls not approved by the factory will be at the owner's risk.

## CAUTION

1. All literature shipped with this unit should be kept for future use for servicing or service diagnostics. Do not discard any literature shipped with this unit.
2. Consult piping, electrical, and venting instructions in this manual before final installation.
3. Do not attach ductwork, air filters, or polytubes to any propeller unit heater.
4. Clearances to combustible materials are critical. Be sure to follow all listed requirements.
5. Heaters are designed for use in heating applications with ambient startup temperatures between -40°F and 90°F and ambient operating temperatures between 40°F and 90°F.
6. Do not install unit outdoors.
7. In garages or other sections of aircraft hangars such as offices and shops that communicate with areas used for servicing or storage, keep the bottom of the unit at least 7' above the floor unless the unit is properly guarded to provide user protection from moving parts. In parking garages, the unit must be installed in accordance with the standard for parking structures ANSI/NFPA 88A - latest edition, and in repair garages the standard for repair garages NFPA 30A - latest edition (formerly NFPA 88B). In Canada, installation of heaters in airplane hangars must be in accordance with the requirements of the enforcing authority, and in public garages in accordance with the current CSA-B149 codes.
8. In aircraft hangars, keep the bottom of the unit at least 10' from the highest surface of the wings or engine enclosure of the highest aircraft housed in the hangars and in accordance with the requirements of the enforcing authority and/or NFPA 409 - latest edition.
9. Installation of units in high humidity or salt water atmospheres will cause accelerated corrosion, resulting in a reduction of the normal life of the units.
10. Do not install units below 7' measured from the bottom of the unit to the floor in commercial applications (unless unit is properly guarded to provide user protection from moving parts).
11. Be sure no obstructions block air intake and discharge of unit heaters.
12. The minimum distance from combustible material is based on the combustible material surface not exceeding 160°F. Clearance from the top of the unit may be required to be greater than the minimum specified if heat damage, other than fire, may occur to materials above the unit heater at the temperature described.
13. Allow 18" of clearance at rear (or 12" beyond end of motor at rear of unit, whichever is greater) and access side to provide ample air for proper operation of fan.
14. Installation must conform with local building codes or in the absence of local codes, with the National Fuel Gas Code, ANSI Z223.1 (NFPA 54) - latest edition. In Canada installation must be in accordance with CSA-B149.1.

## SPECIAL PRECAUTIONS / SI (METRIC) CONVERSION FACTORS

### ⚠ CAUTION

15. Purging of air from gas supply line should be performed as described in the National Fuel Gas Code, ANSI Z223.1 (NFPA 54) - latest edition. In Canada, installation must be in accordance with CSA-B149.1.
16. When leak testing the gas supply piping system, the appliance and its combination gas control must be isolated during any pressure testing in excess of 14" W.C. (1/2 psi).
17. The unit should be isolated from the gas supply piping system by closing its field installed manual shut-off valve. This manual shut-off valve should be located within 6' of the heater.
18. Turn off all gas before installing appliance.
19. Ensure that the supply voltage to the appliance, as indicated on the serial plate, is less than 5% below the rated voltage.
20. Check the gas inlet pressure at the unit upstream of the combination gas control. The inlet pressure should be 6-7" W.C. on natural gas or 12-14" W.C. on propane. If inlet pressure is too high, install an additional pressure regulator upstream of the combination gas control.
21. Service or repair of this equipment must be performed by a qualified service agency.
22. Do not attempt to reuse any mechanical or electronic ignition controller which has been wet. Replace defective controller.

### IMPORTANT

1. To prevent premature heat exchanger failure, do not locate ANY gas-fired appliances in areas where corrosive vapors (i.e. chlorinated, halogenated, or acidic) are present in the atmosphere.
2. To prevent premature heat exchanger failure, the input to the appliance as indicated on the serial plate, must not exceed the rated input by more than 5%.
3. Start-up and adjustment procedures must be performed by a qualified service agency.

### BEFORE YOU BEGIN

### ⚠ CAUTION

1. All literature shipped with this unit should be kept for future use for servicing or service diagnostics. Leave manual with the owner. Do not discard any literature shipped with this unit.
2. Consult piping, electrical, and venting instructions in this manual before final installation.
3. Do not attach ductwork, air filters, or polytubes to any propeller unit heater.

In the U.S., the installation of these units must comply with the National Fuel Gas Code, ANSI Z223.1 (NFPA 54) - latest edition and other applicable local building codes. In Canada, the installation of these units must comply with local plumbing or waste water codes and other applicable codes and with the current code CSA-B149.1.

1. All installation and service of these units must be performed by a qualified installation and service agency only as defined in ANSI Z223.1 (NFPA 54) - latest edition or in Canada by a licensed gas fitter.
2. This unit is certified with the controls furnished. For replacements parts, please order according to the replacement parts list on serial plate. Always know your model and serial numbers. Modine reserves the right to substitute other authorized controls as replacements.
3. Unit is balanced for correct performance. Do not alter fan or operate motors at speeds below what is shown in this manual.
4. Information on controls is supplied separately.
5. The same burner is used for natural and propane gas.

### SI (Metric) Conversion Factors

To Convert	Multiply By	To Obtain
"W.C.	0.249	kPa
°F	(°F-32) x 5/9	°C
BTU	1.06	kJ
Btu/ft <sup>3</sup>	37.3	kJ/m <sup>3</sup>
Btu/hr	0.000293	kW
CFH (ft <sup>3</sup> /hr)	0.000472	m <sup>3</sup> /min
CFH (ft <sup>3</sup> /hr)	0.00000787	m <sup>3</sup> /s
CFM (ft <sup>3</sup> /min)	0.0283	m <sup>3</sup> /min
CFM (ft <sup>3</sup> /min)	0.000472	m <sup>3</sup> /s
feet	0.305	m
Gal/Hr.	0.00379	m <sup>3</sup> /hr
Gal/Hr.	3.79	l/hr
gallons	3.79	l
Horsepower	746	W
inches	25.4	mm
pound	0.454	kg
psig	6.89	kPa
psig	27.7	"W.C.

# SI (METRIC) CONVERSION FACTORS / UNIT LOCATION

## UNIT LOCATION



### DANGER

Appliances must not be installed where they may be exposed to a potentially explosive or flammable atmosphere.



### CAUTION

- Clearances to combustible materials are critical. Be sure to follow all listed requirements.
- Heaters are designed for use in heating applications with ambient startup temperatures between -40°F and 90°F and ambient operating temperatures between 40°F and 90°F.
- Do not install unit outdoors.
- In garages or other sections of aircraft hangars such as offices and shops that communicate with areas used for servicing and storage, keep the bottom of the unit at least 7' above the floor unless the unit is properly guarded. In parking garages, the unit must be installed in accordance with the standard for parking structures ANSI/NFPA 88A - latest edition, and in repair garages the standard for repair garages NFPA 30A - latest edition (formerly NFPA 88B). In Canada, installation of heaters in airplane hangars must be in accordance with the requirements of the enforcing authority, and in public garages in accordance with the current CSA-B149 codes.
- In aircraft hangars, keep the bottom of the unit at least 10' from the highest surface of the wings or engine enclosure of the highest aircraft housed in the hangars and in accordance with the requirements of the enforcing authority and/or NFPA 409 – latest edition.
- Installation of units in high humidity or salt water atmospheres will cause accelerated corrosion resulting in a reduction of the normal life of the units.

### IMPORTANT

To prevent premature heat exchanger failure, do not locate ANY gas-fired appliances in areas where corrosive vapors (i.e. chlorinated, halogenated or acidic) are present in the atmosphere.

### Location Recommendations

- When locating the heater, consider general space and heating requirements, availability of gas and electrical supply, and proximity to vent locations.
- Avoid installing units in extremely drafty locations. Drafts can cause burner flames to impinge on heat exchangers which shortens life. Maintain separation between units so discharge from one unit will not be directed into the inlet of another.
- Be sure the structural support at the unit location site is adequate to support the unit's weight. For proper operation the unit must be installed in a level horizontal position.
- Do not install units in locations where the flue products can be drawn into the adjacent building openings such as windows, fresh air intakes, etc.
- Be sure that the minimum clearances to combustible materials and recommended service clearances are maintained. Units are designed for installation on non-combustible surfaces with the minimum clearances shown in Figure 4.1 and Tables 4.1 and 4.2.
- Units exposed to inlet air temperatures of 40°F or less, may experience condensation, therefore, provisions should be made for disposal of condensate.
- When locating units, it is important to consider that the exhaust vent piping must be connected to the outside atmosphere.
- Maximum equivalent vent lengths are listed in "Section A - General Instruction - All Units" of the Venting Instructions.

- Do not install units in locations where gas ignition system is exposed to water spray, rain, or dripping water.
- Do not install units below 7', measured from the bottom of the unit to the floor, unless properly guarded to provide protection from moving parts.

Figure 4.1 - Combustible Material and Service Clearances

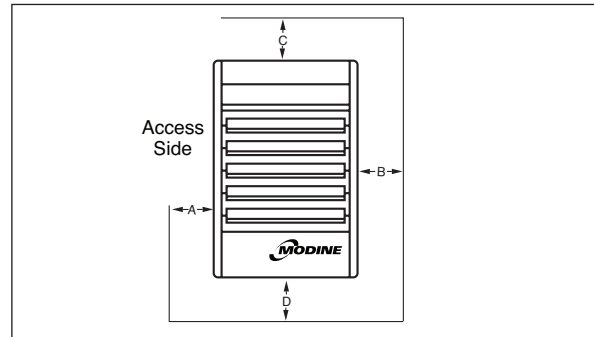

Table 4.1 - Combustible Material Clearances ①

Model Size	Access Side (A)	Non-Access Side (B)	Top (C)	Bottom (D)	Top of Power Exhauster (Not shown)
150-175	1"	1"	4"	12"	2"
200-400	1"	1"	5"	12"	3"

① Provide sufficient room around the heater to allow for proper combustion and operation of fan. Free area around the heater must not be less than 1-1/2 times the discharge area of the unit.

Table 4.2 - Recommended Service Clearances

Model Size	Access Side (A)	Non-Access Side (B)	Top (C)	Bottom (D)	Top of Power Exhauster (Not shown)
150-175	18"	18"	6"	22"	2"
200-400	18"	18"	6"	25"	3"

### Combustion Air Requirements

The National Fuel Gas Code defines an "unconfined space" as a space whose volume is greater than 50 cubic feet per 1,000 Btu/Hr input of the installed appliance(s). A confined space is 50 cubic feet or less per 1,000 Btu/Hr input of the installed appliance(s).

Units installed in tightly sealed buildings or confined spaces must be provided with two permanent openings, one near the top of the confined space and one near the bottom. Each opening should have a free area of not less than one square inch per 1,000 BTU per hour of the total input rating off all units in the enclosure, freely communicating with interior areas having, in turn adequate infiltration from the outside.

For further details on supplying combustion air to a confined (tightly sealed) space or unconfined space, see the National Fuel Gas Code ANSI Z223.1 (NFPA 54) or CSA-B149.1 Installation Code - latest edition.

### Sound and Vibration Levels

All standard mechanical equipment generates some sound and vibration that may require attenuation. Libraries, private offices and hospital facilities will require more attenuation, and in such cases, an acoustical consultant may be retained to assist in the application. Locating the equipment away from the critical area is desirable within ducting limitations. Generally, a unit should be located within 15' of a primary support beam. Smaller deflections typically result in reduced vibration and noise transmission.

# INSTALLATION

## UNIT MOUNTING

1. Be sure the means of suspension is adequate to support the weight of the unit (see pages 24 and 25 for unit weights).
2. For proper operation and to assure that flames are directed into the center of the heat exchanger tubes, the unit must be installed in a level horizontal position. Use a spirit level to ensure that the unit is suspended correctly.
3. Clearances to combustibles as specified in Figure 4.1 and Tables 4.1 and 4.2 must be strictly maintained.
4. All standard units are shipped fully boxed. Larger units are also supplied with skid supports on the bottom of the box. The larger units may be lifted from the bottom by means of a fork lift or other lifting device only if the shipping support skids are left in place and the forks support the whole depth of the unit. If the unit must be lifted from the bottom for final installation without the carton in place, be sure to properly support the unit over its entire length and width to prevent damage. When lifting units, make sure the load is balanced.
5. Propeller models up to size 350 have 2 mounting holes, size 350 and above have 4 mounting holes and blower models up to size 350 have 4 mounting holes, size 350 and above have 6 mounting holes. Units with two point suspension incorporate a level hanging feature. Depending on what options and accessories are being used, the heater may not hang level as received from the factory. Do not hang heaters with deflector hoods until referring to the "Installation Manual for Deflector Hoods" and making the recommended preliminary adjustments on the heater, while the heater is resting on the floor. The units can be mounted with 3/8"-16 threaded rod as follows:

- On each piece of threaded rod used, screw a nut a distance of about 1" onto the end of the threaded rods that will be screwed into the unit heater.
- Place a washer over the end of the threaded rod and screw the threaded rod into the unit heater weld nuts on the top of the heater at least 5 turns, and no more than 10 turns. Tighten the nut first installed onto the threaded rod to prevent the rod from turning.
- Drill holes into a steel channel or angle iron at the same center-line dimensions as the heater that is being installed. The steel channels or angle iron pieces need to span and be fastened to appropriate structural members.
- Cut the threaded rods to the preferred length, place them through the holes in the steel channel or angle iron and secure with washers and lock nuts or lock washers and nuts. A double nut arrangement can be used here instead of at the unit heater (a double nut can be used both places but is not necessary).
- Do not install standard unit heaters above the maximum mounting height shown in Table 19.1.

**NOTE:** A pipe hanger adapter kit, shown in Figure 5.2 is available as an accessory. One kit consists of two drilled 3/4" IPS pipe caps and two 3/8" - 16 x 1-3/4" capscrews to facilitate threaded pipe suspension. Two kits would be required for PDP unit sizes 350 and 400 and all BDP units except size 350 and 400, and 3 kits for BDP unit sizes 350 and 400.

Figure 5.1 - Adjustable Mounting Brackets - To Adjust:

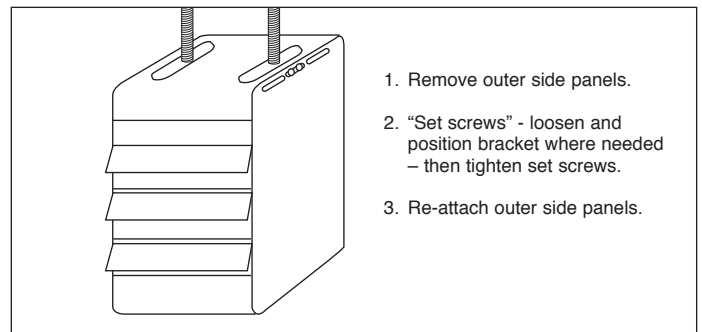
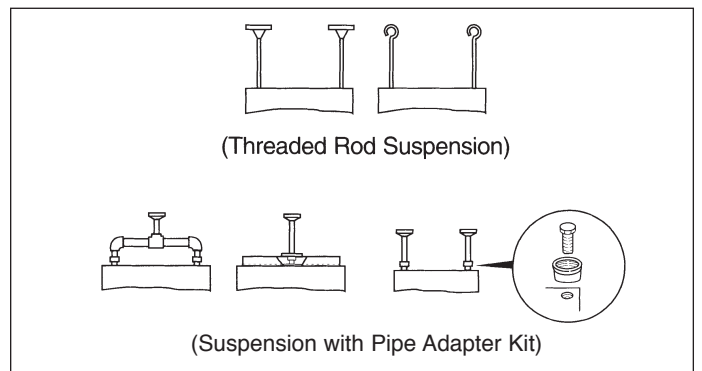

Figure 5.2 - Suspension Methods



# INSTALLATION - VENTING

## ⚠ WARNING

1. Gas fired heating equipment must be vented - do not operate unvented.
2. A built-in power exhauster is provided - additional external power exhausters are not required or permitted.
3. If an existing heater is being replaced, it may be necessary to resize the venting systems. Improperly sized venting systems can result in vent gas leakage or the formation of condensate. Refer to the National Fuel Gas Code ANSI Z223.1 (NFPA 54) or CSA B149.1 - latest edition. Failure to follow these instructions can result in serious injury or death.
4. Under no circumstances should two sections of double wall vent pipe be joined together within one horizontal vent system due to the inability to verify complete seal of inner pipes.

## ⚠ CAUTION

Installation must conform with local building codes or in the absence of local codes, with the National Fuel Gas Code, ANSI Z223.1 (NFPA 54) - latest edition. In Canada installation must be in accordance with CSA B149.1.

Model PDP and BDP unit heaters must be vented with the proper passageway as described in these instructions to convey flue gases from the unit or the vent connector to the outside atmosphere.

The venting instructions are organized in sections, based on installation type. The sections are identified as follows:

Instructions	Applicable Installation Instructions by Vent System Type
A	General Instructions for <b>ALL</b> Installations
B	<b>VERTICAL CATEGORY I</b> vent systems ①
C	<b>HORIZONTAL CATEGORY III</b> vent systems ①

① The differences between vertical and horizontal vent systems will be identified in "Section A - General Instructions - All Units".

### Section A - General Instructions - All Units

- A1. If the unit heater being installed is replacing existing equipment and using the existing vent system from that equipment, inspect the venting system for proper size and horizontal pitch, as required in the National Fuel Gas Code, ANSI Z223.1 (NFPA 54) or CSA B149.1 Installation Code - latest edition and these instructions. Determine that there is no blockage or restriction, leakage, corrosion and other deficiencies, which could cause an unsafe condition.
- A2. The vent pipe should be galvanized steel or other suitable corrosion resistant material. Follow the National Fuel Gas Code for minimum thickness of vent material. The minimum thickness for connectors varies depending on the pipe diameter. Do not vent unit with PVC or other forms of plastic venting material.
- A3. All heaters come with a vent adapter for attaching the vent pipe to the heater (see Table 6.1). Attach the vent pipe to the adapter with 3 corrosion resistant screws. (Drill pilot holes through the vent pipe and adapter prior to screwing in place). Vent pipe must not be smaller than the connector size.
- A4. Limit the total equivalent vent pipe length to fall between the minimum and maximum equivalent vent lengths given

in Table 6.1, making the vent system as straight as possible. The equivalent length of a 5" elbow is 6' and for a 6" elbow is 7'.

- A5. A minimum of 12" straight pipe is recommended from the flue outlet before turns in the vent pipe.
- A6. Horizontal sections of vent pipe are to be installed with a minimum downward slope from the appliance of 1/4" per foot and suspended securely from overhead structures at points not greater than 3' apart.
- A7. Fasten individual lengths of vent together with at least 3 corrosion resistant sheet metal screws.
- A8. Keep single wall vent pipe at least 6" from combustible materials. For double wall vent pipe, follow the vent pipe manufacturer's clearances to combustibles. The minimum distance from combustible materials is based on the combustible material surface not exceeding 160°F. Clearance from the vent pipe (or the top of the unit) may be required to be greater than 6" if heat damage other than fire could result (such as material distortion or discoloration).
- A9. Avoid venting through unheated space when possible. When venting does pass through an unheated space or if the unit is installed in an environment that promotes condensation, insulate runs greater than 5' to minimize condensation. Inspect for leakage prior to insulating and use insulation that is noncombustible with a rating of not less than 400°F. Install a tee fitting at the low point of the vent system and provide a drip leg with a clean out cap as shown in Figure 8.1.

**Table 6.1 - Vent Pipe Diameters, Transitions, and Total Equivalent Vent Pipe Lengths for Horizontal Vent Systems**

Model Size	Vent Transition Included	Vent Pipe Diameter	Minimum Eqv Length	Maximum Eqv Length
150, 175	4" to 5"	5"	2'	60'
200	6" to 5"	5"	2'	60'
250-400	Not required	6"	2'	70'

**Figure 6.1 - Venting Through Combustible Roof or Wall**

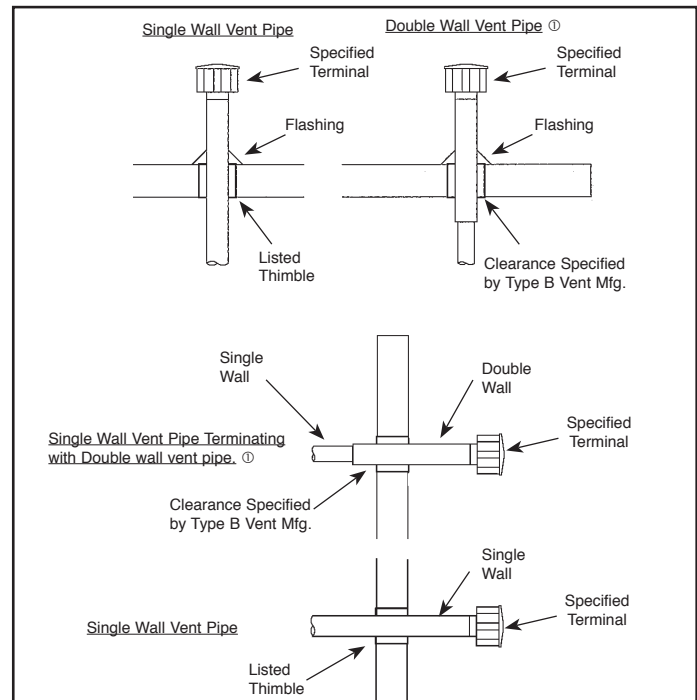

① See Instruction A12 for attaching single wall pipe to double wall pipe.

# INSTALLATION - VENTING

- A10. When the vent passes through a combustible INTERIOR wall or floor, a metal thimble 4" greater than the vent diameter is necessary. If there is 6' or more of vent pipe in the open space between the appliance and where the vent pipe passes through the wall or floor, the thimble need only be 2" greater than the diameter of the vent pipe. If a thimble is not used, all combustible material must be cut away to provide 6" of clearance. Where authorities have jurisdiction, Type B vent may be used for the last section of vent pipe to maintain clearance to combustibles while passing through wall or floor. See Figure 6.1. Any material used to close the opening must be noncombustible.
- A11. All seams and joints of the single wall pipe must be sealed with metallic tape or silastic suitable for temperatures up to 400°F. Wrap the tape 2 full turns around the vent pipe. One continuous section of double wall vent pipe may be used within the vent system to pass through the wall to the listed vent cap. Refer to instruction A12 in "Section A – General Instructions – All Units" for attaching double wall pipe to single wall pipe.
- A12. The following are general instructions for double wall (Type B) terminal pipe installation:

### How to attach a single wall vent terminal to double wall (Type B) vent pipe:

1. Look for the "flow" arrow on the vent pipe.
2. Slide the vent terminal inside the exhaust end of the double wall vent pipe.
3. Drill 3 holes through the pipe and the vent terminal. Using 3/4" long sheet metal screws, attach the cap to the pipe. Do not over tighten.

### How to connect a single wall vent system to a double wall (Type B) vent pipe:

1. Slide the single wall pipe inside the inner wall of the double wall pipe.
2. Drill 3 holes through both walls of the single and double wall vent pipes. Using 3/4" sheet metal screws, attach the 2 pieces of pipe. Do not over tighten.
3. The gap between the single and double wall pipe must be sealed but it is not necessary to fill the full volume of the annular area. To seal, run a large bead of 400°F silastic around the gap.

A13. Vent termination clearances must be maintained:

**Table 7.1 - Vent Termination Clearances**

Structure	Minimum Clearances for Vent Terminal Location
Forced air inlet within 10'	3' above
Combustion air inlet of another appliance	6' all directions
Door, window, gravity air inlet, or any building opening	4' horizontal and below 1' above
Electric meter, gas meter, gas regulator, and relief equipment ①	4' horizontal (U.S.) 6' horizontal (Canada)
Gas regulator ①	3' horizontal (U.S.) 6' horizontal (Canada)
Adjoining building or parapet wall	6' all directions
Adjacent public walkways	7' all directions
Grade (ground level)	3' above

① Do not terminate the vent directly above a gas meter or regulator.

- A14. Do NOT vent this appliance into a masonry chimney.
- A15. Do NOT use dampers or other devices in the vent or combustion air pipes.

- A16. The venting system must be exclusive to a single appliance and no other appliance is allowed to be vented into it.
- A17. Precautions must be taken to prevent degradation of building materials by flue products.
- A18. Single wall vent pipe must not pass through any unoccupied attic, inside wall, concealed space, or floor.
- A19. Uninsulated single wall vent pipe must not be used outdoors for venting appliances in regions where the 99% winter design temperature is below 32°F.
- A20. The vent terminal must be:

**Table 7.2 - Vent Terminals**

Model Size	Modine PN	Other Listed Terminals
150-200	5H0722850001	Gary Steel 1092, Tjernlund VH1, Starkap, Selkirk, or Constant Air-Flo 2433 style
250-400	5H0722850002	

- A21. If left hand (facing front of heater with air blowing in face) power exhauster discharge is desired, the power exhauster may be rotated 180°. To do this, remove the screws in the vent collar, rotate the power exhauster, then replace the screws.
- A22. In addition to following these general instructions, specific instructions for Vertical Category I or Horizontal Category III vent systems must also be followed. The following outlines the differences:

**Table 7.3 - ANSI Unit Heater Venting Requirements**

Category	Description	Venting Requirements
I	Negative vent pressure Non-condensing	Follow standard venting requirements.
II	Negative vent pressure Condensing	Condensate must be drained.
III	Positive vent pressure Non-condensing	Vent must be gas tight.
IV	Positive vent pressure Condensing	Vent must be liquid and gas tight. Condensate must be drained.

**Note:** Vent connectors serving Category I appliances shall not be connected into any portion of mechanical draft systems operating under positive pressure.

### Vertical Category I Vent

- Vertical vent systems terminate vertically (up) (an example is shown in Figure 8.1).
- The horizontal portion of the vent run cannot exceed 75% of the vertical rise (Example: If the vent height is 10', the horizontal portion of the vent system cannot exceed 7.5').
- The vent terminates a minimum of 5' above the vent connector on the unit.
- If the vent system to be installed meets ALL these criteria (an example is shown in Figure 8.1), proceed to "Section B - Vertical Vent System Installation". For all other cases, proceed to the next section for Horizontal Category III Vent System Determination:

### Horizontal Category III Vent

- Horizontal vent systems terminate horizontally (sideways) (an example is shown in Figure 9.2).
- A vent system that terminates vertically but has a horizontal run that exceeds 75% of the vertical rise is considered horizontal.
- Horizontal vent configurations are Category III. Additional requirements are covered in "Section C - Horizontal Category III Vent System Installation".

# INSTALLATION - VENTING

## Section B – Vertical Vent System Installation

- B1. This section applies to vertically vented Category I vent systems and is in addition to “Section A – General Instructions – All Units”.
- B2. Vertical vent systems terminate vertically and must be sized in accordance with the National Fuel Gas Code, ANSI Z223.1 (NFPA 54) - latest edition.
- B3. The horizontal portion of the vent run cannot exceed 75% of the vertical rise (Example: If the vent height is 10', the horizontal portion of the vent system cannot exceed 7.5').
- B4. It is recommended to install a tee with drip leg and clean out cap as shown in Figure 8.1.
- B5. The vent terminates a minimum of 5' above the vent connector on the unit.
- B6. All vertically vented heaters that are Category I must be connected to a vent complying with a recognized standard, with a material acceptable to the authority having jurisdiction. Venting into a masonry chimney is not permitted. Refer to the National Fuel Gas Code, ANSI Z223.1 (NFPA 54) - latest edition for instructions on common venting.
- B7. Use a listed vent terminal to reduce down drafts and moisture in the vent.
- B8. Double wall vent pipe is recommended, although single wall can be used if the requirements of the National Fuel Gas Code are followed.
- B9. Vertical vents must terminate a minimum horizontal and vertical distance from roof lines and adjacent walls or obstructions. These minimum distances are outlined as follows (based on National Fuel Gas Code requirements for vents with diameters less than 12"):
- For **double wall** vent pipe and **8' or greater** horizontal distance to any vertical wall or similar obstruction, the vent must terminate above the roof in accordance with Figure 8.1 and Table 8.1.
  - For **double wall** vent pipe and **less than 8'** horizontal distance to any vertical wall or similar obstruction, the vent must terminate at least 2' above the highest point where it passes through a roof of a building and at least 2' higher than any portion of a building within a horizontal distance of 10' (see Figure 8.1).

Figure 8.1 - Vertical Category I Vent System

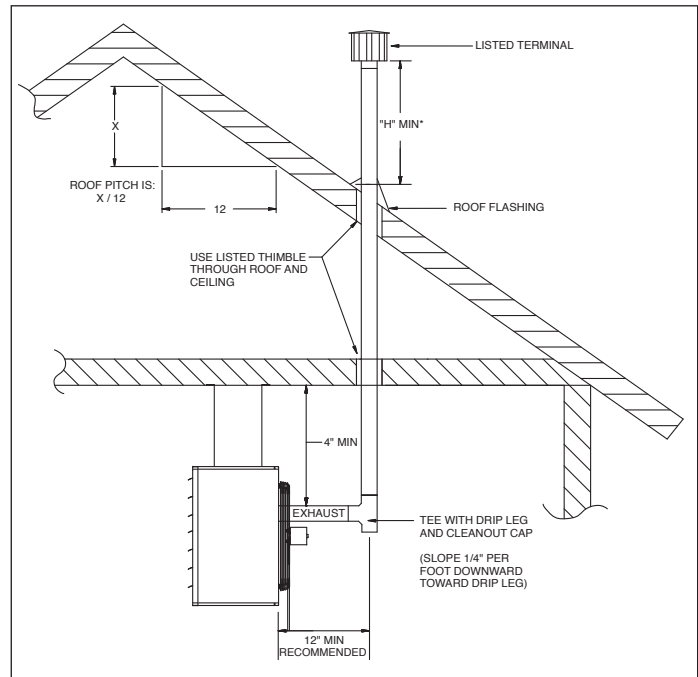

Table 8.1 - Minimum Height from Roof to Lowest Discharge Opening

Rise X (in)	Roof Pitch	Min Height H (ft) ①
0-6	Flat to 6/12	1.00
6-7	6/12 to 7/12	1.25
7-8	7/12 to 8/12	1.50
8-9	8/12 to 9/12	2.00
9-10	9/12 to 10/12	2.50
10-11	10/12 to 11/12	3.25
11-12	11/12 to 12/12	4.00
12-14	12/12 to 14/12	5.00
14-16	14/12 to 16/12	6.00
16-18	16/12 to 18/12	7.00
18-20	18/12 to 20/12	7.50
20-21	20/12 to 21/12	8.00

① Size according to expected snow depth.

- For **single wall** vent pipe and 10' or greater horizontal distance to any portion of a building, the vent must terminate at least 2' above the highest point where it passes through a roof of a building and at least 2' higher than any portion of a building within a horizontal distance of 10'.
- For **single wall** vent pipe and less than 10' horizontal distance to any portion of a building, the vent must terminate at least 2' higher than any portion of that building.



# INSTALLATION - VENTING

## Section C – Horizontal, Category III Vent System Installation

- C1. This section applies to horizontally vented Category III vent systems and is in addition to “Section A – General Instructions – All Units”.
- C2. Horizontal vent systems terminate horizontally (sideways).
- C3. All seams and joints must be sealed with metallic tape or silastic suitable for temperatures up to 400°F. Wrap the tape 2 full turns around the vent pipe. For single wall vent systems, 1 continuous section of double wall vent pipe may be used within the vent system to pass through the wall to the listed vent cap. Under no circumstances should 2 sections of double wall vent pipe be joined together within 1 vent system due to the inability to verify complete seal of inner pipes. Refer to instruction A10 in “Section A – General Instructions – All Units” for attaching double wall pipe to single wall pipe.
- C4. Refer to Table 9.1 for total minimum and maximum vent lengths, making the system as straight as possible. The equivalent length of a 90° elbow is 6' for 5" diameter and 7' for 6" diameter.
- C5. All horizontal Category III vents must be terminated with a listed vent cap. The cap must terminate a minimum distance beyond the exterior wall surface as shown in Figure 9.2 and Table 9.1. The vent must be supported as shown in Figure 9.1. Precautions must be taken to prevent degradation of building materials by flue products.

**Table 9.1 - Dimension Between Vent Cap and Exterior Wall**

Vent Terminal	“A” Min.
Selkirk, Starkap, or Constant Air-Flo 2433	12"
Gary Metals 1092 or Modine 5H072285	6"
Tjernlund VH1	0"

**Figure 9.1 - Exhaust Vent Construction Through Combustible Walls and Support Bracket**

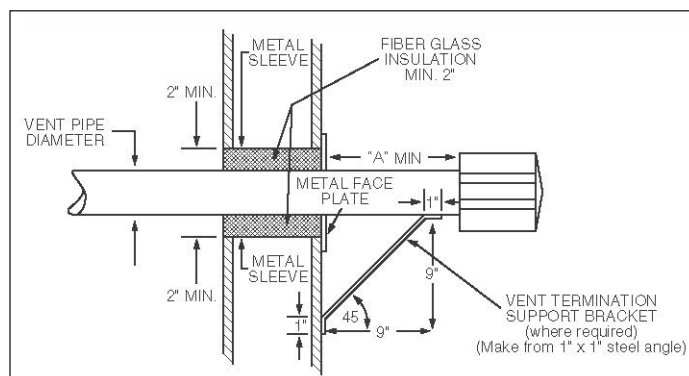

- C6. When condensation may be a problem, the vent system shall not terminate over public walkways or over an area where condensate or vapor could create a nuisance or hazard or could be detrimental to the operation of regulators, relief openings, or other equipment.
- C7. The venting system must be exclusive to a single unit, and no other unit is allowed to be vented into it.
- C8. When vented horizontally, maintain a 1/4" per foot rise away from the heater and place a drip leg with clean out near the unit as shown in Figure 9.2.

**Figure 9.2 - Horizontal Venting**

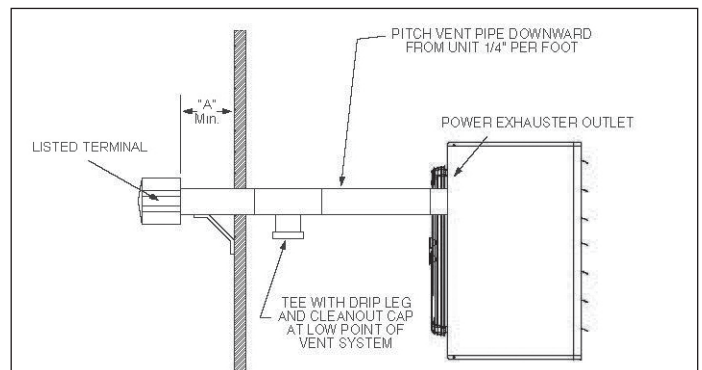

- C9. For a vent termination located under an eave, the distance of the overhang must not exceed 24". The clearance to combustibles above the exterior vent must be maintained at a minimum of 12". Consult the National Fuel Gas Code for additional requirements for eaves that have ventilation openings.
- C10. Once venting is complete, proceed to the section titled “Installation – Gas Connections”.

# INSTALLATION

## GAS CONNECTIONS

### ⚠ WARNING

1. All field gas piping must be pressure/leak tested prior to operation. Never use an open flame. Use a soap solution or equivalent for testing.
2. Gas pressure to appliance controls must never exceed 14" W.C. (1/2 psi).
3. To reduce the opportunity for condensation, the minimum sea level input to the appliance, as indicated on the serial plate, must not be less than 5% below the rated input, or 5% below the minimum rated input of dual rated units.

### ⚠ CAUTION

1. Purging of air from gas lines should be performed as described in the National Fuel Gas Code, ANSI Z223.1 (NFPA 54) - latest edition or in Canada CSA-B149 codes.
2. When leak testing the gas supply piping system, the appliance and its combination gas control must be isolated during any pressure testing in excess of 14" W.C. (1/2 psi).
3. The unit should be isolated from the gas supply piping system by closing its field installed manual shut-off valve. This manual shut-off valve should be located within 6' of the heater.
4. Turn off all gas before installing appliance.

### IMPORTANT

To prevent premature heat exchanger failure, the input to the appliance, as indicated on the serial plate, must not exceed the rated input by more than 5%.

1. Installation of piping must conform with local building codes, or in the absence of local codes, with the National Fuel Gas Code, ANSI Z223.1 (NFPA 54) - Latest Edition. In Canada, installation must be in accordance with CSA-B149.1.
2. Piping to units should conform with local and national requirements for type and volume of gas handled, and pressure drop allowed in the line. Refer to Table 10.1 to determine the cubic feet per hour (cfh) for the type of gas and size of unit to be installed. Using this cfh value and the length of pipe necessary, determine the pipe diameter from Table 10.2. Where several units are served by the same main, the total capacity, cfh and length of main must be considered. Avoid pipe sizes smaller than 1/2". Table 10.1 allows for a 0.3" W.C. pressure drop in the supply pressure from the building main to the unit. The inlet pressure to the unit must be 6-7" W.C. for natural gas and 11-14" W.C. for propane gas. When sizing the inlet gas pipe diameter, make sure that the unit supply pressure can be met after the 0.3" W.C. has been subtracted. If the 0.3" W.C. pressure drop is too high, refer to the Gas Engineer's Handbook for other gas pipe capacities.
3. Install a ground joint union with brass seat and a manual shut-off valve adjacent to the unit for emergency shut-off and easy servicing of controls, including a 1/8" NPT plugged tapping accessible for test gauge connection (see Figure 10.1).
4. Use 2 wrenches when connecting field piping to units.
5. Provide a sediment trap before each unit and in the line where low spots cannot be avoided (see Figure 10.1).
6. When pressure/leak testing, pressures above 14" W.C. (1/2 psi), close the field installed shut-off valve, disconnect the appliance and its combination gas control from the gas supply line, and plug the supply line before testing. When testing pressures 14" W.C. (1/2 psi) or below, close the manual shut-off valve on the appliance before testing.

**Figure 10.1 - Recommended Sediment Trap/Manual Shut-off Valve Installation for Gas Connection**

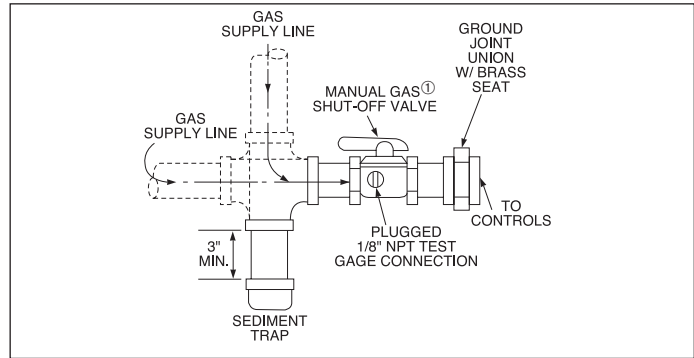

① Manual shut-off valve is in the "OFF" position when handle is perpendicular to pipe.

**Table 10.1 - Sea Level Manifold Pressure & Gas Consumption ①**

Model Size	Manifold Pressure ("W.C.)	Natural	Propane	# of Orifices
		3.5	10	
150	CFH	138.1	58.0	2
	Gal/Hr. Propane	-	1.64	
	Orifice Drill Size	21	39	
175	CFH	166.7	70.0	3
	Gal/Hr. Propane	-	1.86	
	Orifice Drill Size	28	43	
200	CFH	190.5	80.0	3
	Gal/Hr. Propane	-	2.19	
	Orifice Drill Size	25	42	
250	CFH	238.1	100.0	3
	Gal/Hr. Propane	-	2.74	
	Orifice Drill Size	18	36	
300	CFH	285.7	120.0	4
	Gal/Hr. Propane	-	3.29	
	Orifice Drill Size	21	39	
350	CFH	333.3	140.0	5
	Gal/Hr. Propane	-	3.84	
	Orifice Drill Size	23	41	
400	CFH	381.0	160.0	6
	Gal/Hr. Propane	-	4.38	
	Orifice Drill Size	25	42	

**Table 10.2 - Gas Pipe Capacities - Natural Gas ① ②**

Pipe Length (ft)	Natural Gas					
	1/2"	3/4"	1"	1-1/4"	1-1/2"	2"
10	132	278	520	1050	1600	3050
20	92	190	350	730	1100	2100
30	73	152	285	590	890	1650
40	63	130	245	500	760	1450
50	56	115	215	440	670	1270
60	50	105	195	400	610	1150
70	46	96	180	370	560	1050
80	43	90	170	350	530	930
100	38	79	150	305	460	870
125	34	72	130	275	410	780
150	31	64	120	250	380	710

① Capacities in cubic feet per hour through Schedule 40 pipe with maximum 0.3" W.C. pressure drop with up to 14" W.C. gas pressure. Specific gravity is 0.60 for natural gas and 1.50 for propane gas.

② For pipe capacity with propane gas, divide natural gas capacity by 1.6. Example: What is the propane gas pipe capacity for 60' of 1-1/4" pipe? The natural gas capacity is 400 CFH. Divide by 1.6 to get 250 CFH for propane gas.

# INSTALLATION - HIGH ALTITUDE ACCESSORY KIT

## HIGH ALTITUDE ACCESSORY KIT

Modine's gas-fired equipment standard input ratings are certified by ETL. For elevations above 2,000', ANSI Z223.1 requires ratings be reduced 4 percent for each 1000' above sea level. For units in Canada, CSA requires that ratings be reduced 10 percent at elevations above 2,000'. The high altitude adjustment instructions and pressure switch kits listed in this manual are for use with units that will be installed over 2,000'. These methods and kits comply with both ANSI Z223.1 and CSA requirements.

If a unit is to be installed at higher elevations AND converted from natural gas to propane gas operation, a propane conversion kit must be used in conjunction with the pressure adjustment methods and pressure switch kits listed herein. For the Selection and Installation Instructions for propane conversion kits, please see the latest revision of Modine Manual 75-511.

### Selection of the Proper Pressure and Kit

To determine the proper manifold pressure at altitude and if required, the proper combustion air pressure switch kit, the full model number of the heater, the fuel to be used, and the altitude the unit will be installed at must be known. Refer to the unit serial plate or carton label to obtain the necessary information about the unit.

After obtaining this information, refer to the gas pressure and selection charts shown in Tables 11.1 through 11.3. The pressure charts are differentiated by elevation, fuel type, and country the product is being installed in. The selection charts are differentiated by product type, altitude and fuel type. **If converting from natural gas to propane gas and operation at high altitude, both a propane conversion kit and a pressure switch kit must be used (if applicable).** Selection charts include the proper kit suffix, when required.

**Table 11.1 - Natural Gas Heating Values at Altitude** ① ③ ④

Altitude (ft)	Gas Heating Values at Altitude (BTU/ft <sup>3</sup> )	
	USA	Canada
0-2,000	1,050	1,050
2,001-3,000	929	945
3,001-4,000	892	
4,001-4,500	874	
4,501-5,000	856	856
5,001-6,000	822	822
6,001-7,000	789	789
7,001-8,000	757	757
8,001-9,000	727	727
9,001-10,000	698	698

- ① Values shown are for 3.5" W.C. manifold pressure, for other BTU content values (available from local utility) use Equation 12.1 to calculate manifold pressure.
- ② Values shown are for 10.0" W.C. manifold pressure, for other BTU content values (available from local utility) use Equation 12.1 to calculate manifold pressure.
- ③ When installed at altitudes above 2,000', a pressure switch may need to be changed. Refer to Table 11.3 to determine if a switch change is required.
- ④ Gas heating values are derated 4% per 1,000' of elevation in the USA and 10% between 2,000' and 4,500' elevation in Canada in accordance with ANSI Z223.1 and CSA-B149, respectively.

**Table 11.3 - High Altitude Kits for PDP/BDP** ①

Model Size	Details	U.S.A. and Canada				
		0-2,000 ft	2,001-4,500 ft	4,501-5,500 ft	5,501-6,500 ft	6,501-7,500 ft
150-400	Kit Suffix	Not required	Label only	Label only	Label only	Label only
	Item Code					

- ① For Label Only kits, Modine part number 5H0807146005 is required to be filled out and attached to the unit by the installer. Please contact the local Modine representative at 1.866.828.4328 (HEAT).

## Manifold Pressure Adjustment

The inlet pressure to the unit must be confirmed to be within acceptable limits (6-7" W.C. for natural gas and 11-14" W.C. for propane gas) before opening the shutoff valve or the combination gas valve may be damaged.

Heaters for use with **natural gas** have gas valves factory set at 3.5" W.C. manifold pressure at 7.0" W.C. inlet pressure.

Units for use with **propane gas** are set for 10.0" W.C. manifold pressure at 14.0" W.C. inlet pressure.

Installation above 2,000' elevation requires adjustment of the manifold pressure as described.

## Derated BTU Content Gas and Manifold Pressure Calculation

Some utility companies may derate the BTU content (heating value) of the gas provided at altitude to a value other than 1,050 BTU/ft<sup>3</sup> for natural gas or 2,500 BTU/ft<sup>3</sup> for propane gas to allow certain heating appliances to be used with no manifold pressure adjustments. For this reason it is necessary that the supplying utility be contacted for detailed information about the gas type and BTU content (heating value) before operating any heater. Tables 11.1 and 11.2 show the standard derated heating values (4% per 1,000' of elevation in the USA and 10% between 2,001' and 4,500' elevation in Canada) of natural and propane gases at various altitudes. If the utility is supplying gas with heating values as shown in Tables 11.1 and 11.2, the manifold pressure should be set to 3.5" W.C for natural gas and 10.0" W.C. for propane gas.

**NOTE:** Only the high fire gas pressure need be adjusted, low fire gas pressure should remain the same.

**Table 11.2 - Propane Gas Heating Values at Altitude** ② ③ ④

Altitude (ft)	Gas Heating Values at Altitude (BTU/ft <sup>3</sup> )	
	USA	Canada
0-2,000	2,500	2,500
2,001-3,000	2,212	2,250
3,001-4,000	2,123	
4,001-4,500	2,080	
4,501-5,000	2,038	2,038
5,001-6,000	1,957	1,957
6,001-7,000	1,879	1,879
7,001-8,000	1,803	1,803
8,001-9,000	1,731	1,731
9,001-10,000	1,662	1,662

## INSTALLATION - HIGH ALTITUDE ACCESSORY KIT

If the heating value of the gas being supplied is different than the values shown in Tables 11.1 and 11.2, use the following equation to determine the appropriate manifold pressure for the altitude and gas heating value being supplied.

### Equation 12.1 - Manifold Pressure for Derated Gas

$$MP_{ACT} = \left( \frac{BTU_{TBL}}{BTU_{ACT}} \right)^2 \times MP_{SL}$$

#### WHERE:

$MP_{ACT}$  = **Manifold Pressure (in. W.C.) at Altitude** –  
Manifold pressure setting for the heater being installed

$BTU_{TBL}$  = **BTU/ft<sup>3</sup> Content of Gas** –  
Obtained from Tables 11.1 or 11.2 (whichever is applicable)

$BTU_{ACT}$  = **BTU/ft<sup>3</sup> Content of Gas** –  
Obtained from the local utility company

$MP_{SL}$  = **Manifold Pressure (in. W.C.), at Sea Level** –  
Use 3.5" W.C. for natural gas and 10.0" W.C. for propane gas

**NOTE:** Only the primary manifold pressure should be adjusted on units equipped with 2-stage or modulating gas controls. No adjustments to the low fire manifold pressure are necessary on these units.

# INSTALLATION

## ELECTRICAL CONNECTIONS

### ⚠ WARNING

1. Disconnect power supply before making wiring connections to prevent electrical shock and equipment damage.
2. All appliances must be wired strictly in accordance with wiring diagram furnished with the appliance. Any wiring different from the wiring diagram could result in a hazard to persons and property.
3. Any original factory wiring that requires replacement must be replaced with wiring material having a temperature rating of at least 105°C.
4. Ensure that the supply voltage to the appliance, as indicated on the serial plate, is not 5% greater than rated voltage.

### ⚠ CAUTION

Ensure that the supply voltage to the appliance, as indicated on the serial plate, is not 5% less than the rated voltage.

1. Installation of wiring must conform with local building codes, or in the absence of local codes, with the National Electric Code ANSI/NFPA 70 - Latest Edition. Unit must be electrically grounded in conformance to this code. In Canada, wiring must comply with CSA C22.1, Part 1, Electrical Code.
  2. Two copies of the unit wiring diagram are provided with each unit. One is located in the electrical junction box and the other is supplied in the literature packet. Refer to this diagram for all wiring connections.
  3. Make sure all multi-voltage components (motors, transformers, etc.) are wired in accordance with the power supply voltage.
  4. The power supply to the unit must be protected with a fused or circuit breaker switch.
  5. The power supply must be within 10 percent of the voltage rating and each phase must be balanced within 2 percent of each other. If not, advise the utility company.
  6. External electrical service connections that must be installed include:
    - a. Supply power connection (120, 208, 240, 480, or 575 volts).
    - b. Thermostats, summer/winter switches, or other accessory control devices that may be supplied (24 volts).
- NOTE:** Certain units will require the use of a field step-down transformer. Refer to the serial plate to determine the unit supply voltage required. Additional information may be found in Tables 19.2 and 19.3 and in the step down transformer installation instructions.
7. Refer to Figure 18.1 for the electrical junction box locations.
  8. All supply power electrical connections are made in the electrical junction box of the unit. The low voltage (thermostat and accessory control devices) can be wired to the terminals on the electrical junction box. Refer to the wiring diagram for the terminal location of all low voltage wiring.

## DUCT INSTALLATION

### IMPORTANT

Do not attempt to attach ductwork of any kind to propeller models.

When installing the heater, always follow good duct design practices for even distribution of the air across the heat exchanger. Recommended layouts are shown in Figure 13.1. When installing blower units with ductwork the following must be done.

1. **Provide uniform air distribution over the heat exchanger.** Use turning vanes where required (see Figure 13.1).
2. Provide removable access panels in the ductwork on the downstream side of the unit heater. These openings should be large enough to view smoke or reflect light inside the casing to indicate leaks in the heat exchanger and to check for hot spots on exchanger due to poor air distribution or lack of sufficient air.
3. If ductwork is connected to the rear of the unit use a Modine blower enclosure kit or if using a field designed enclosure maintain dimensions of the blower enclosure as shown on page 25.

Figure 13.1 - Recommended Ductwork Installations

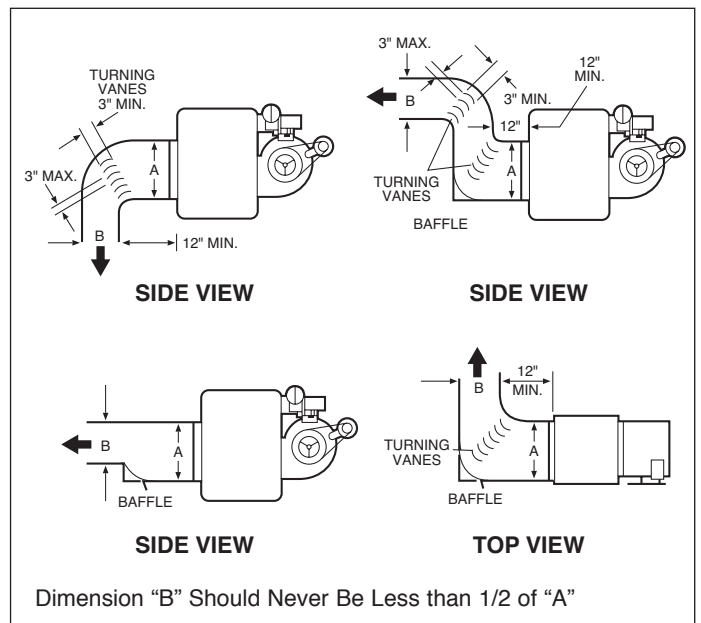

## Additional Requirements for Blower Model BDP

### Determining Blower Speed

The drive assembly and motor on all blower units are factory assembled and adjusted for operation under average conditions of air flow and without any external static pressure. The motor sheave should be adjusted as required when the unit is to be operated at other than average air flows and/or with external static pressures. Adjustment must always be within the performance range shown on page 20 and the temperature rise range shown on the unit's rating plate.

To determine the proper blower speed and motor sheave turns open, the operating conditions must be known. For example, a model BDP350 unit, operating with no external static pressure, (e.g. no ductwork, nozzles, etc.) is to deliver an air volume of 6481 cfm (cfm = cubic feet per minute). This requires the unit be supplied with a 5 hp motor, a -207 drive, and the drive sheave set at 2.5 turns open to achieve a blower speed of 960

# INSTALLATION

rpm (see performance table for units with or without blower enclosure, page 20). See "Blower Adjustments" for setting of drive pulley turns open.

If a blower unit is to be used with ductwork or nozzles, etc., the total external static pressure under which the unit is to operate, and the required air flow must be known before the unit can be properly adjusted. Any device added externally to the unit, and which the air must pass through, causes a resistance to air flow called pressure loss.

If Modine filters are used, the pressure loss through the filters is included in the performance data on page 20. If Modine supplied discharge nozzles are used, the pressure drop of the nozzles can be found footnoted at the bottom of page 23. If filters, nozzles or ductwork are to be used with the unit, and they are not supplied by Modine, the design engineer or installing contractor must determine the pressure loss for the externally added devices or ductwork to arrive at the total external static pressure under which the unit is to operate.

Once the total static pressure and the required air flow are known, the operating speed of the blower can be determined and the correct motor sheave adjustments made. As an example, a model BDP350 is to be used with a Modine supplied blower enclosure and filters attached to ductwork by others. The unit is to move 6481 cfm of air flow against an external static pressure of 0.2" W.C, which must be added for the filter pressure drop for a total of 0.4" W.C. total pressure drop. The performance table on page 20 for a BDP350, at 6481 cfm and 0.4" W.C. static pressure, shows that the unit will require a 5 hp motor using a -207 drive, and the motor sheave should be set at .5 turns open to achieve a blower speed of 1050 rpm.

## To Install

1. Remove and discard the motor tie down strap and the shipping block beneath the belt tension adjusting screw (Not used on all models.)
2. For 3 and 5 HP motors, affix sheave to the motor shaft and install motor on the motor mounting bracket. Install belt on blower and motor sheaves.

Figure 14.1 - Blower Model

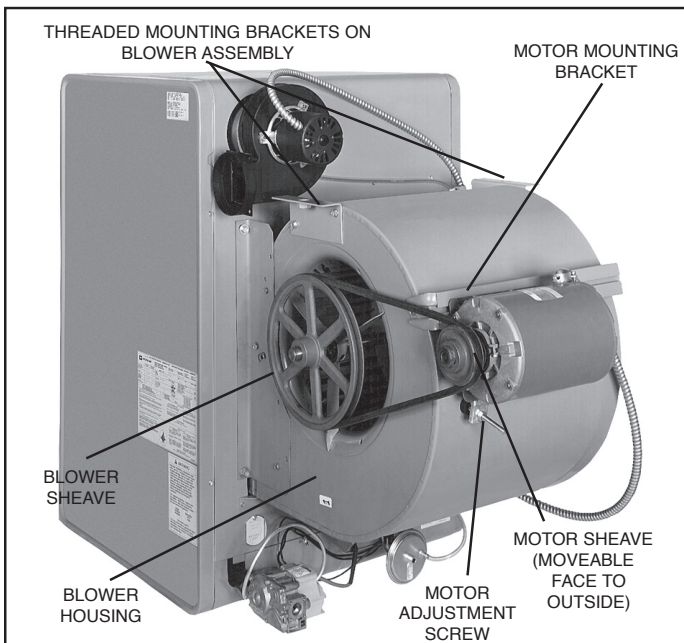

3. Adjust motor adjusting screw for a belt deflection of approximately 3/4" with five pounds of force applied midway between the sheaves (see Figure 14.3). Since the belt tension will decrease dramatically after an initial run-in period, it is necessary to periodically re-check the tension. Excessive tension will cause bearing wear and noise.
4. The blower bearings are lubricated for life; however, before initial unit operation the blower shaft should be lubricated at the bearings with SAE 20 oil. This will reduce initial friction and start the plastic lubricant flowing.
5. Make electrical connections as outlined in the section "Electrical Connections" on page 13.

## Blower Adjustments

Following electrical connections, check blower rotation to assure blow-through heating. If necessary interchange wiring to reverse blower rotation. Start fan motor and check blower sheave RPM with a hand-held or strobe-type tachometer. RPM should check out with the speeds listed in "Performance Data" shown on page 20. A single-speed motor with an adjustable motor sheave is supplied with these units. If blower fan speed changes are required, adjust motor sheave as follows:

**NOTE: Do not fire unit until blower adjustment has been made or unit may cycle on limit (overheat) control.**

1. **Shut-off power before making blower speed adjustments.** Refer to "Determining Blower Speed" on page 13 and to "Performance Data" on page 20 to determine proper blower RPM.
2. Loosen belt and remove from motor sheave.
3. Loosen set screw on outer side of adjustable motor sheave (see Figure 14.2).
4. To reduce the speed of the blower, turn outer side of motor sheave counterclockwise.
5. To increase the speed of the blower, turn outer side of motor sheave clockwise.
6. Retighten motor sheave set screw, replace belt and retighten motor base. Adjust motor adjusting screw such that there is 3/4" belt deflection when pressed with 5 pounds of force midway between the blower and motor sheaves (see Figure 14.3). Since the belt tension will decrease dramatically after an initial run-in period, it is necessary to periodically re-check the tension to assure proper belt adjustment.
7. Check to make certain motor sheave and blower sheave are aligned. Re-align if necessary.
8. Re-check blower speed after adjustment.
9. Check motor amps. Do not exceed amps shown on motor nameplate. Slow blower if necessary.
10. Check air temperature rise across unit. Check temperature rise against values shown in Performance Tables on page 20 to assure actual desired air flow is being achieved.
11. If adjustments are required, recheck motor amps after final blower speed adjustment.

Figure 14.2 - Motor Sheave Adjustment

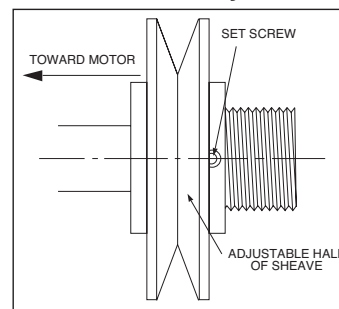
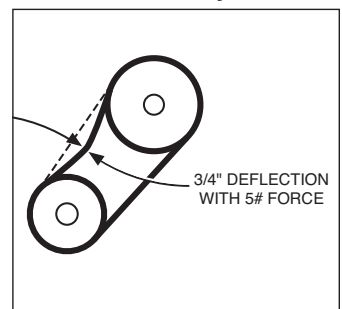

Figure 14.3 - Belt Tension Adjustment



# START-UP PROCEDURE

## IMPORTANT

1. To prevent premature heat exchanger failure, observe heat exchanger tubes. If the bottom of the tubes become red while blower and furnace are in operation, check to be sure the blower has been set to the proper rpm for the application. Refer to page 14 for blower adjustments.
2. Start-up and adjustment procedures must be performed by a qualified service agency.

1. Turn off power to the unit at the disconnect switch. Check that fuses or circuit breakers are in place and sized correctly. Turn all hand gas valves to the "OFF" position.
2. Remove electrical junction box cover.
3. Check that the supply voltage matches the unit supply voltage listed on the Model Identification Plate. Verify that all wiring is secure and properly protected. Trace circuits to insure that the unit has been wired according to the wiring diagram. If installed at altitudes above 2,000' and the high altitude kit includes a combustion air proving switch, replace the switch in the unit with the switch provided in the kit. Take care to ensure that the tubing and electrical connections are securely fastened.
4. Check to insure that the venting system is installed correctly and free from obstructions.
5. Check to see that there are no obstructions to the intake and discharge of the unit.
6. For blower units, check the belt tension and sheave alignment. Refer to "Blower Adjustments" for proper belt tension.
7. Check bearings for proper lubrication (if applicable).
8. Check to make sure that all filters are in place and that they are installed properly according to direction of air flow (if applicable).
9. Perform a visual inspection of the unit to make sure no damage has occurred during installation. Lower bottom pan and visually inspect all components in the burner compartment. Check to ensure all fasteners are in place and the burner openings are properly aligned with the heat exchanger tubes and that the gas orifices are centered in the burner inspirator tube opening opening, as shown in Figure 16.2.
10. Check that all horizontal deflector blades are open a minimum of 30° as measured from vertical.
11. Turn on power to the unit at the disconnect switch. Check to insure that the voltage between electrical junction box terminals T1 and G is 24V.
12. Check the thermostat, ignition control, gas valve, and supply fan blower motor for electrical operation. If these do not function, recheck the wiring diagram. Check to insure that none of the Control Options have tripped.
13. Check the blower wheel for proper direction of rotation when compared to the air flow direction arrow on the blower housing (if applicable). Blower wheel rotation, not air movement, must be checked as some air will be delivered through the unit with the blower wheel running backwards.
14. For blower units, check the blower speed (rpm). Refer to "Blower Adjustments" for modification.
15. Check the motor speed (rpm).
16. Check the motor voltage. On three phase systems, check to make sure all legs are in balance.
17. Check the motor amp draw to make sure it does not exceed the motor nameplate rating. On three phase systems, check all legs to insure system is balanced.
18. Recheck the gas supply pressure at the field installed manual shut-off valve. The minimum inlet pressure should be 6" W.C. on natural gas and 11" W.C. on propane gas. The maximum inlet pressure for either gas is 14" W.C. If inlet pressure exceeds 14" W.C., a gas pressure regulator must be added upstream of the combination gas valve.

19. Open the field installed manual gas shut-off valve.
20. Open the manual main gas valve on the combination gas valve. Call for heat with the thermostat and allow the pilot to light for intermittent pilot ignition. If the pilot does not light, purge the pilot line. If air purging is required, disconnect the pilot line at outlet of pilot valve. In no case should line be purged into heat exchanger. Check the pilot flame length (See "Pilot Flame Adjustment").
21. Once the pilot has been established, check to make sure that the main gas valve opens. Check the manifold gas pressure (see "Main Gas Adjustment") and flame length (see "Air Shutter Adjustment") while the supply fan blower is operating. Inspect the condition of the main flame and if necessary, resolve flame appearance problems (see "Burner Flame Adjustment" and Figures 28.1 through 28.4).
22. Check to insure that gas controls sequence properly (see "Control Operating Sequence"). Verify if the unit has any additional control devices and set according to the instructions in the "Control Options".
23. Once proper operation of the unit has been verified, remove any jumper wires that were required for testing.
24. Replace the electrical junction box cover.
25. If installed at altitudes above 2,000', affix label included with high altitude kit and fill in all fields with a permanent marker.

## Pilot Burner Adjustment

The pilot burner is orificed to burn properly with an inlet pressure of 6-7" W.C. on natural gas and 11-14" W.C. on propane gas, but final adjustment must be made after installation. If the pilot flame is too long or large, it is possible that it may cause soot and/or impinge on the heat exchanger, causing failure. If the pilot flame is shorter than shown, it may cause poor ignition and result in the controls not opening the combination gas control. A short flame can be caused by a dirty pilot orifice. Pilot flame condition should be observed periodically to assure trouble-free operation.

### To Adjust the Pilot Flame

1. Create a call for heat from the thermostat.
2. Remove the cap from the pilot adjustment screw. For location, see the combination gas control literature supplied with unit.
3. Adjust the pilot length by turning the screw in or out to achieve a soft steady flame 3/4" to 1" long and encompassing 3/8"-1/2" of the tip of the thermocouple or flame sensing rod (see Figure 15.1).
4. Replace the cap from the pilot adjustment screw.

Figure 15.1 - Correct Pilot Flame

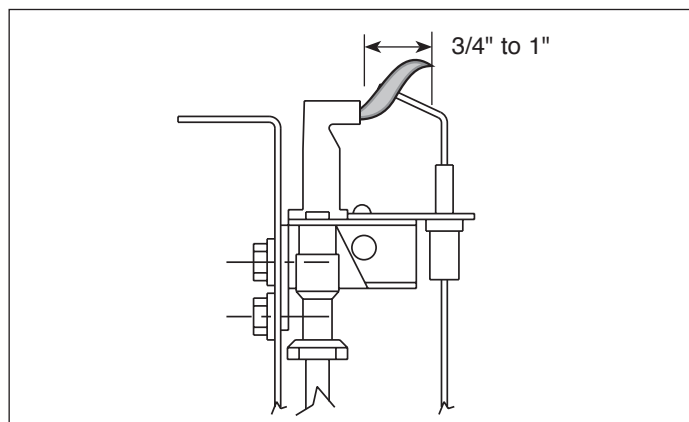

# START-UP PROCEDURE

## Main Burner Adjustment

The gas pressure regulator (integral to the combination gas control) is adjusted at the factory for average gas conditions. It is important that gas be supplied to the unit heater in accordance with the input rating on the serial plate. Actual input should be checked and necessary adjustments made after the unit heater is installed. Over-firing, a result of too high an input, reduces the life of the appliance and increases maintenance. Under no circumstances should the input exceed that shown on the serial plate.

Measuring the manifold pressure is done at the outlet pressure tap of the gas valve (see Figure 16.1).

### To Adjust the Manifold Pressure

1. Move the field installed manual shut-off valve to the "OFF" position.
2. Remove the 1/8" pipe plug in the pipe tee or gas valve and attach a water manometer of "U" tube type which is at least 12" high.
3. Move the field installed manual gas shut-off valve to the "ON" position.
4. Create a high fire call for heat from the thermostat.
5. Determine the correct high fire manifold pressure (3.5" W.C. for natural gas, 10" W.C. for propane gas). (Pressures at 0-2,000' elevation are 3.5" W.C. for natural gas, 10" W.C. for propane gas, for elevations above 2,000' refer to the instructions in "Gas Connections - High Altitude Accessory Kit" on page 11). Adjust the main gas pressure regulator spring to achieve the proper manifold pressure (for location, see the combination gas control literature supplied with unit).
6. After adjustment, move the field installed manual shut-off valve to the "OFF" position and replace the 1/8" pipe plug.
7. After the plug is in place, move the field installed manual shut-off valve to the "ON" position and recheck pipe plugs for gas leaks with soap solution.

## Burner Flame Adjustment

Proper operation provides a soft blue flame with a well-defined inner core. A lack of primary air will reveal soft yellow-tipped flames. Excess primary air produces short, well-defined flames with a tendency to lift off the burner ports. For both natural and propane gas, the flame may be adjusted by sliding the manifold. Also, for propane gas, the air shutters can be adjusted to control the burner flame height. The air shutters can be accessed by lowering the bottom pan of the unit heater.

### Natural Gas Flame Control

Control of burner flames on unit heaters utilizing natural gas is achieved by resetting the manifold position to either increase or decrease primary combustion air. Prior to flame adjustment, operate unit heater for about fifteen minutes. The main burner flame can be viewed after loosening and pushing aside the gas designation disc on the back of the unit.

To increase primary air, loosen the manifold mounting screws and move the manifold away from the burner until the yellow-tipped flames disappear (see Figure 16.2). To decrease primary air, move manifold closer to the burner until flames no longer lift from burner ports, but being careful not to cause yellow tipping. Retighten manifold mounting screws after adjustment.

### Propane Gas Flame Control

An optimum flame will show a slight yellow tip. Prior to flame adjustment, operate heater for at least 15 minutes. Loosen air shutter set screws and move the air shutters away from the manifold to reduce the primary air until the yellow flame tips appear (see Figure 16.3). Then increase the primary air until yellow tips diminish and a clean blue flame with a well-defined inner cone appears.

It may also be necessary to adjust the manifold position in addition to adjusting air shutters to obtain proper flame. Follow the instructions under "Natural Gas Flame Control" for adjusting the manifold.

Figure 16.1 - Typical Combination Gas Control

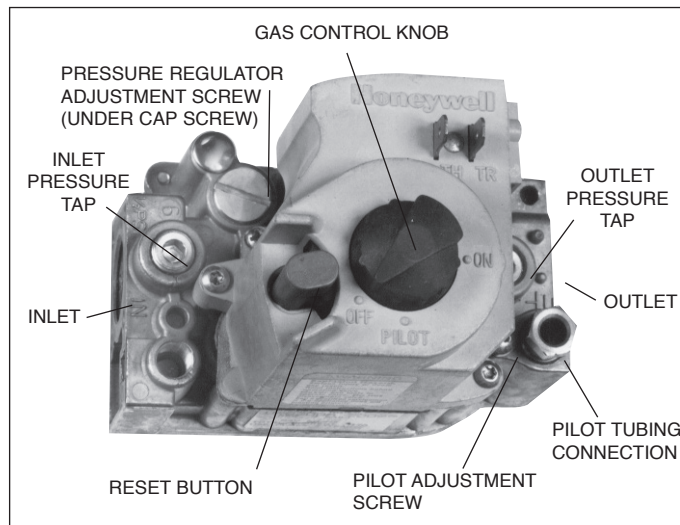

Figure 16.2 - Manifold Adjustment, Natural Gas

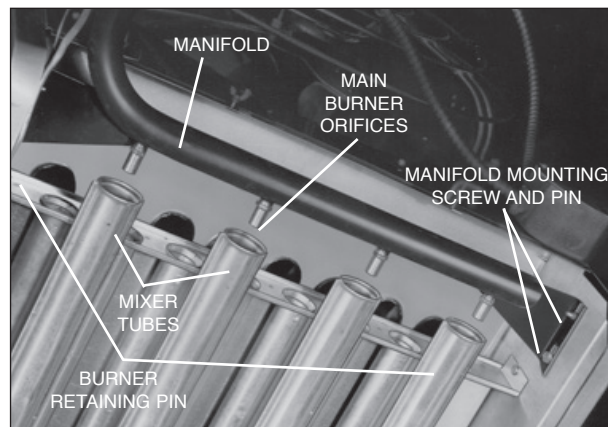
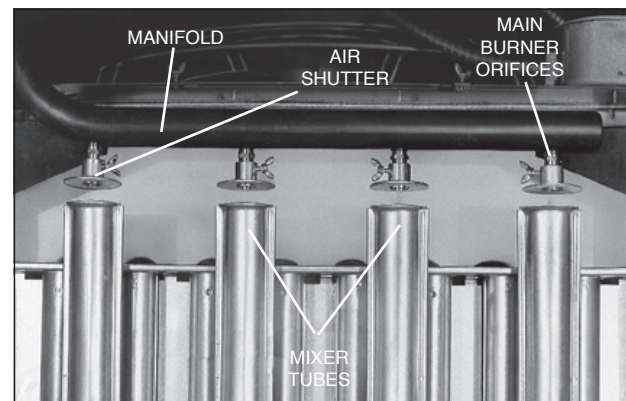

Figure 16.3 - Air Shutter Adjustment, Propane Gas





# START-UP PROCEDURE

## Control Operating Sequence

All units are supplied with intermittent pilot systems with continuous retry control as standard. For intermittent pilot systems, both the main burner and pilot are turned off 100% when the thermostat is satisfied. For all units, the system will attempt to light the pilot for 70 seconds. If the pilot is not sensed, the ignition control will wait approximately 6 minutes with the combination gas control closed and no spark. After 6 minutes, the cycle will begin again. After 3 cycles, some ignition controllers lockout for approximately 1 hour before the cycle begins again. This will continue indefinitely until the pilot flame is sensed or power is interrupted to the system. Refer to Table 18.1 for control code descriptions. Specific descriptions of the control sequence for different control codes are listed below.

1. The thermostat calls for heat.
2. The power exhauster relay is energized, starting the power exhauster motor. Once the motor has reached full speed, the differential pressure switch closes.
3. The pilot valve opens and the ignitor sparks for 70 seconds in an attempt to light the pilot.
4. Once the pilot is lit, the flame sensor proves the pilot and stops the ignitor from sparking.
5. On single stage units, the main gas valve is opened and the main burner is lit to 100% full fire. On two stage units, the gas valve may open at either 50% or 100%, depending on what the two stage thermostat is calling for.
6. The air mover starts after 30 to 90 seconds to allow the heat exchanger to warm up.
7. The unit continues to operate until the thermostat is satisfied, at which time both the main and pilot valves close 100%.
8. The air mover stops after 30 to 90 seconds to remove residual heat from the heat exchanger.

# UNIT AND CONTROL OPTIONS

Figure 18.1 - Factory Mounted Option Location

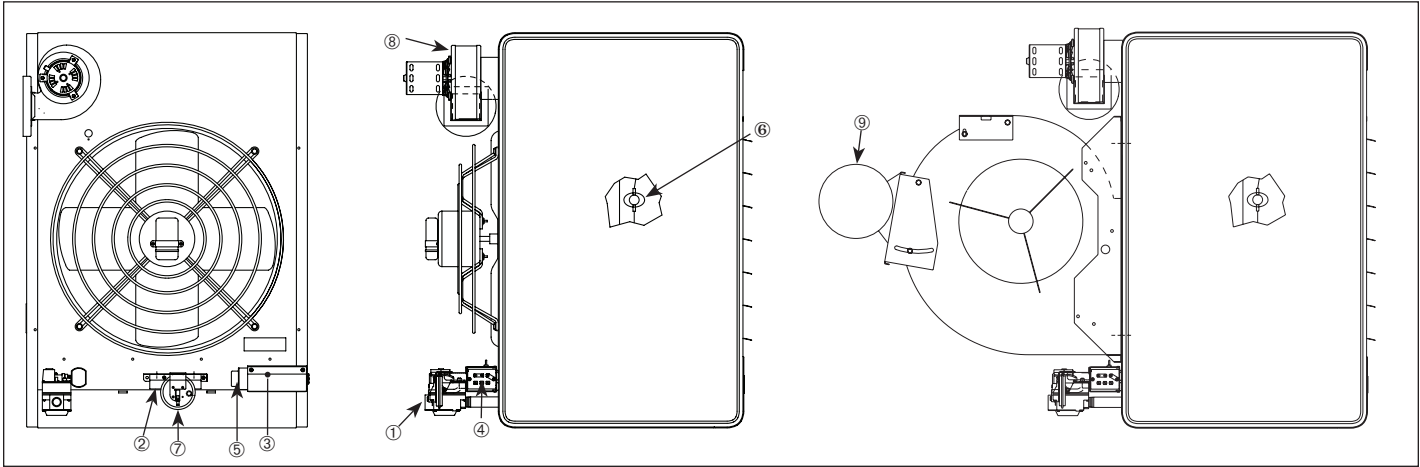

All units include the standard (STD) features. The unit must be reviewed to determine the optional (OPT) features that may have been supplied with the unit.

## ① Gas Valve

### a) Single Stage Gas Valve - (STD)

The main gas valve provides the pilot, regulator, main gas, and manual shutoff functions. For additional information, see the supplier literature included with the unit.

### b) Two Stage Gas Valve - (OPT)

The two stage gas valve provides the pilot, regulator, main gas (100% and 50% fire), and manual shutoff functions. For additional information, see the supplier literature included with the unit.

## ② Ignition controller - (STD)

The ignition controller is factory installed on the back of the unit heater with the spark igniter and sensor located on the burner. For additional information, refer to “Control Operating Sequence” on page 16 and the supplier literature included with the unit.

## ③ Time Delay Relay - (STD)

The time delay relay is factory installed in electrical junction box and controls propeller/blower motor function. For single-phase units below 2 Hp, the time delay relay controls the motor directly. For single-phase units 2 Hp and greater and all three phase units, the time delay relay controls the motor starter. For additional information, refer to “Control Operating Sequence” on page 17.

## ④ Low Voltage Terminal Board - (STD)

The low voltage terminal board is located in the electrical junction box. The terminal board is labeled to match the electrical wiring diagram provided with the unit. All low voltage field wiring connections should be made to the exposed side of the terminal board (exterior of electrical junction box) to prevent miswiring by modifying the factory wiring, which is inside the electrical junction box.

## ⑤ Control Step Down Transformer - (STD)

The control step down transformer is located in the electrical junction box. The transformer is used to step down the supply power (115V, 208V, 230V, 460V, 575V) to 24V. This transformer is used to control the gas controls, fan delay relay, field supplied motor starter, etc. All unit heaters are supplied with a 40VA control step down transformer. To determine the control transformer supplied as well as any accessory/field supplied transformers required, reference the supply voltage listed on the serial plate and reference Tables 19.2 and 19.3.

## ⑥ High Limit Switch - (STD)

The automatic reset high limit switch is factory installed on the left side (air blowing at you) of the unit heater. If the limit temperature is exceeded, the gas controls are de-energized until the switch is cooled.

## ⑦ Pressure Switch (STD)

An automatic reset vent pressure switch is designed to prevent operation of the main burner if there is restricted venting of flue products. This restriction may occur due to an improper vent diameter, long vent runs, unapproved vent terminal, high winds, high negative pressure within space, etc. After the cause of the restriction has been corrected, the pressure switch will reset automatically. See the troubleshooting section for more information.

## ⑧ Power Exhauster (STD)

All power vented unit heaters are supplied with a round vent pipe connection. Some models may require the use of a vent transition from the power exhauster outlet to the vent pipe (see Table 6.1). The power exhauster may be rotated 180° to allow for various venting directions.

## ⑨ Blower Motor - (STD on BDP models only)

The blower motor can be provided in a variety of supply voltages and motor horsepowers. Refer to the model nomenclature to determine the motor provided. The blower motor is supplied with an adjustable sheave that can be used to increase/decrease the blower RPM. For instructions on changing the blower RPM, refer to “Blower Adjustments.”

Table 18.1 - Control Descriptions - Models PDP & BDP

Control System Description	Control Code		Service Voltage	Thermostat Voltage
	Natural Gas	Propane Gas		
Single-Stage ①	30	85	115V	25V
	31	86	208/230V	25V
	32	93	460V ②	25V
	33	94	575V ②	25V
Two-Stage ①	63	87	115V	25V
	64	88	208/230V	25V

① All controls are intermittent pilot ignition, 100% shut-off with continuous retry.  
 ② Factory wired 460/575 available on blower models. Field installed step down transformer may be used for 460/575 propeller applications.

# GENERAL PERFORMANCE DATA

**Table 19.1 - Performance - Propeller (PDP) and Blower (BDP) Models ① ②**

	Model Number													
	PDP 150	PDP 175	PDP 200	PDP 250	PDP 300	PDP 350	PDP 400	BDP 150	BDP 175	BDP 200	BDP 250	BDP 300	BDP 350	BDP 400
Btu/Hr. Input	150,000	175,000	200,000	250,000	300,000	350,000	400,000	150,000	175,000	200,000	250,000	300,000	350,000	400,000
Btu/Hr. Output	120,000	140,000	160,000	200,000	240,000	280,000	320,000	120,000	140,000	160,000	200,000	240,000	280,000	320,000
Entering Airflow (CFM)	2180	2550	2870	3700	4460	4870	5440	2020	2357	2694	3367	4040	4714	5387
CFM Range	-	-	-	-	-	-	-	1587-2778	1852-3241	2116-3704	2646-4630	3175-5556	3704-6481	4233-6584
Air Temp. Rise (°F)	51	51	52	50	50	53	54	40-70	40-70	40-70	40-70	40-70	40-70	40-70
Max. Mounting Hgt. (Ft) ③	16	17	15	19	21	20	19	14	15	13	16	18	19	19
Heat Throw (Ft) ③ (Max. Mtg. Hgt.)	55	59	51	67	74	70	69	49	52	47	58	64	67	68
Motor Type	PSC	PSC	PSC	PSC	PSC	PSC	PSC	For motor size details, refer to pages 20 and 21.						
HP 115/60/1 (PC01)	1/8	1/6	1/6	1/3	1/2	3/4	3/4							
HP 230/60/1 (PC02)	1/8	1/6	1/6	1/3	1/2	3/4	3/4							
HP 208/60/1 (PC03)	N/A	1/6	1/6	N/A	N/A	N/A	N/A							

**Table 19.2 - Electrical Details Propeller Units**

Power				Control Code Selected	Factory Installed Transformer	Additional Field Installed Transformers
Supply Voltage		Unit Voltage				
Voltage	Phase	Voltage	Phase			
115	1	115	1	30,63,85,87	115V to 24V	none
208	1	115	1	30,63,85,87	115V to 24V	208V to 115V
208	1	208	1	31,64,86,88	208V to 24V	none
208	3	115	1	30,63,85,87	115V to 24V	208V to 115V ④
230	1	115	1	30,63,85,87	115V to 24V	208V to 115V ④
230	1	230	1	31,64,86,88	230V to 24V	none
230	3	115	1	30,63,85,87	115V to 24V	230V to 115V ④
460	3	115	1	30,63,85,87	115V to 24V	460V to 115V
575	3	115	1	30,63,85,87	115V to 24V	575V to 115V

**Table 19.3 - Electrical Details Blower Units**

Power				Control Code Selected	Factory Installed Transformer	Additional Field Installed Transformers
Supply Voltage		Unit Voltage				
Voltage	Phase	Voltage	Phase			
115	1	115	1	30,63,85,87	115V to 24V	none
208	1	208	1	31,64,86,88	208V to 24V	none
208	3	208	3	31,64,86,88	208V to 24V	none
230	1	230	1	31,64,86,88	230V to 24V	none
230	3	230	3	31,64,86,88	230V to 24V	none
460 ⑤	3	230 ⑤	3	64,88	230V to 24V	460V to 230V ⑥
460	3	460	3	32,93	460V to 24V	460V to 230V
575 ⑤	3	230 ⑤	3	64,88	230V to 24V	575V to 230V ⑥
575	3	575	3	33,94	575V to 24V	575V to 230V

**Table 19.4 - Motor Data and Total Unit Power Requirements - Propeller Models ①**

Unit Voltage	115/60/1			115/60/1 With Use of Transformer								208/60/1			230/60/1		
	Supply Voltage			208V		230V		460V		575V		208/60/1			230/60/1		
HP	Mtr. Amps	Mtr. Rpm	Total Amps	KVA Req.	Total Amps	KVA Req.	Total Amps	KVA Req.	Total Amps	KVA Req.	Total Amps	Mtr. Amps	Mtr. Rpm	Total Amps	Mtr. Amps	Mtr. RPM	Total Amps
1/8	2.3	1625	4.0	0.50	2.4	0.50	2.17	0.50	1.09	0.50	0.87	1.0	1625	1.9	1.0	1625	1.9
1/6	2.7	1075	5.1	1.00	4.81	0.75	3.26	0.75	1.63	0.75	1.30	1.5	1075	2.8	1.5	1075	2.8
1/3	5.4	1075	7.7	1.00	4.81	1.00	4.35	1.00	2.17	1.00	1.74	---	---	---	2.5	1075	3.7
1/2	7.5	1075	9.8	1.50	7.2	1.50	6.52	1.50	3.26	1.50	2.61	---	---	---	3.5	1075	4.7
3/4	8.8	1125	11.1	1.50	7.2	1.50	6.52	1.50	3.26	1.50	2.61	---	---	---	4.4	1125	5.5

**Table 19.5 - Motor Data and Total Unit Power Requirements - Blower Models ①**

Voltage		115/60/1		230/60/1		208/60/3		230/60/3		460/60/3		575/60/3	
HP	Motor RPM	Motor Amps	Total Amps	Motor Amps	Total Amps	Motor Amps	Total Amps	Motor Amps	Total Amps	Motor Amps	Total Amps	Motor Amps	Total Amps
1/4	1725	3.7	6.0	2.7	5.0	1.4	1.7	1.5	2.8	0.8	2.0	0.5	1.8
1/3	1725	5.0	7.3	2.5	4.8	1.1	2.4	1.1	2.4	0.6	1.9	0.6	1.9
1/2	1725	7.2	9.5	3.6	5.9	2.2	3.4	2.2	3.5	1.1	2.4	0.8	2.1
3/4	1725	11.0	13.3	5.5	7.8	3.0	4.3	3.0	4.3	1.5	2.7	1.3	2.5
1	1725	12.0	14.3	6.0	8.3	3.2	4.5	3.2	4.5	1.6	2.8	1.3	2.4
1-1/2	1725	15.0	17.3	7.5	9.8	4.6	5.9	4.8	6.1	2.4	3.6	1.9	3.1
2	1725	-	-	-	-	6.0	7.3	5.8	7.1	2.9	4.2	2.3	3.5
3	1725	-	-	-	-	8.4	9.7	7.8	9.1	3.9	5.2	3.2	4.4
5	1725	-	-	-	-	13.6	14.9	12.3	13.5	6.2	7.5	5.1	6.3

① All motors are totally enclosed and all single phase motors have built-in thermal overload protection.  
 ② Ratings shown are for elevations up to 2,000'. For elevations above 2,000', ratings should be reduced at the rate of 4% for each 1,000' above sea level. (In Canada see rating plate.) Reduction of ratings requires use of a high altitude kit.  
 ③ Data taken at 55°F air temperature rise. At 65°F ambient and unit fired at full-rated input. Mounting height as measured from bottom of unit, and without deflector hoods.  
 ④ A transformer may not be required. 115V/1φ power may be obtained from the following electrical distribution systems: 230/1φ 3-wire, 230/3φ 4-wire, 208/3φ 4-wire and 208/1φ 3-wire (from 208V wye connected transformer). Please consult the job site electrician to determine applicability.  
 ⑤ Unit power code must match building supply voltage; control voltage must match unit power.  
 ⑥ For Canada certification, step down transformer may be required to be factory installed (blower models only).



# GENERAL PERFORMANCE DATA

Table 21.1 - Power Code Description - Blower Model BDP ①

Power Code	Voltage	Phase	150		175		200		250		300		350		400	
			HP	Drive	HP	Drive	HP	Drive	HP	Drive	HP	Drive	HP	Drive	HP	Drive
01	115	1	1/4	191	-	-	1/4	212	-	-	-	-	-	-	-	-
02	230	1	1/4	191	-	-	1/4	212	-	-	-	-	-	-	-	-
07	575	3	1/4	197	-	-	1/4	213	-	-	-	-	-	-	-	-
08	208-230/460	3	1/4	191	-	-	1/4	212	-	-	-	-	-	-	-	-
09	115	1	1/3	191	1/3	95	1/3	212	1/3	203	3/4	205	1	107	1-1/2	105
10	230	1	1/3	191	1/3	95	1/3	212	1/3	203	3/4	205	1	107	1-1/2	105
15	575	3	1/3	197	1/3	96	1/3	213	1/3	204	3/4	205	1	255	1-1/2	180
16	208-230/460	3	1/3	191	1/3	95	1/3	212	1/3	203	3/4	205	1	255	1-1/2	180
17	115	1	1/3	95	1/2	96	1/3	102	1/2	204	1	205	1-1/2	105	-	-
18	230	1	1/3	95	1/2	96	1/3	102	1/2	204	1	205	1-1/2	105	-	-
23	575	3	1/3	96	1/2	96	1/3	101	1/2	204	1	157	1-1/2	180	2	210
24	208-230/460	3	1/3	95	1/2	96	1/3	102	1/2	204	1	157	1-1/2	180	2	210
25	115	1	1/2	96	3/4	192	1/2	101	3/4	205	1-1/2	106	1-1/2	100	-	-
26	230	1	1/2	96	3/4	192	1/2	101	3/4	205	1-1/2	106	1-1/2	100	-	-
31	575	3	1/2	96	3/4	192	1/2	101	3/4	205	1-1/2	108	1-1/2	210	3	111
32	208-230/460	3	1/2	96	3/4	192	1/2	101	3/4	205	1-1/2	108	1-1/2	33	3	111
33	115	1	3/4	38	1	192	3/4	16	1	205	-	-	-	-	-	-
34	230	1	3/4	38	1	192	3/4	16	1	205	-	-	-	-	-	-
39	575	3	3/4	38	1	256	3/4	16	1	157	2	108	2	210	5	207
40	208-230/460	3	3/4	38	1	256	3/4	16	1	157	2	108	2	210	5	207
41	115	1	1	38	1-1/2	193	1	16	1-1/2	105	-	-	-	-	-	-
42	230	1	1	38	1-1/2	193	1	16	1-1/2	105	-	-	-	-	-	-
47	575	3	1	254	1-1/2	198	1	178	1-1/2	180	3	111	3	111	2	180
48	208-230/460	3	1	254	1-1/2	198	1	178	1-1/2	180	3	111	3	111	2	180
49	115	1	1/4	13	-	-	1-1/2	105	-	-	1-1/2	105	-	-	-	-
50	230	1	1/4	13	-	-	1-1/2	105	-	-	1-1/2	105	-	-	-	-
55	575	3	1/4	14	2	80	1-1/2	180	2	108	1-1/2	110	5	207	3	112
56	208-230/460	3	1/4	13	2	80	1-1/2	180	2	108	1-1/2	180	5	207	3	112
57	115	1	3/4	96	3/4	96	1/4	24	3/4	204	-	-	-	-	-	-
58	230	1	3/4	96	3/4	96	1/4	24	3/4	204	-	-	-	-	-	-
63	575	3	3/4	96	3/4	96	1/4	25	3/4	204	-	-	2	180	5	111
64	208-230/460	3	3/4	96	3/4	96	1/4	24	3/4	204	-	-	2	180	5	111
65	115	1	-	-	1-1/2	79	1/3	24	1-1/2	23	-	-	-	-	-	-
66	230	1	-	-	1-1/2	79	1/3	24	1-1/2	23	-	-	-	-	-	-
71	575	3	-	-	1-1/2	80	1/3	25	1-1/2	177	-	-	5	181	-	-
72	208-230/460	3	-	-	1-1/2	80	1/3	24	1-1/2	177	-	-	5	181	-	-
73	115	1	-	-	-	-	1/2	25	-	-	-	-	-	-	-	-
74	230	1	-	-	-	-	1/2	25	-	-	-	-	-	-	-	-
79	575	3	-	-	-	-	1/2	25	-	-	-	-	-	-	-	-
80	208-230/460	3	-	-	-	-	1/2	25	-	-	-	-	-	-	-	-
81	115	1	-	-	-	-	3/4	101	-	-	-	-	-	-	-	-
82	230	1	-	-	-	-	3/4	101	-	-	-	-	-	-	-	-
87	575	3	-	-	-	-	3/4	101	-	-	-	-	-	-	-	-
88	208-230/460	3	-	-	-	-	3/4	101	-	-	-	-	-	-	-	-
89	115	1	-	-	-	-	1-1/2	23	-	-	-	-	-	-	-	-
90	230	1	-	-	-	-	1-1/2	23	-	-	-	-	-	-	-	-
95	575	3	-	-	-	-	1-1/2	177	-	-	-	-	-	-	-	-
96	208-230/460	3	-	-	-	-	1-1/2	177	-	-	-	-	-	-	-	-

① For selection of correct Power Code, refer to the tables on page 20.

# PERFORMANCE DATA - HOODS

Table 22.1 - Performance Data - 30°, 60° and 90° Downward Deflector Hoods

Mounting Height to Bottom of Heater	30° Downward Hood For Propeller Units													
	PDP ①							BDP ②						
	PDP 150 X Y Z	PDP 175 X Y Z	PDP 200 X Y Z	PDP 250 X Y Z	PDP 300 X Y Z	PDP 350 X Y Z	PDP 400 X Y Z	BDP 150 X Y Z	BDP 175 X Y Z	BDP 200 X Y Z	BDP 250 X Y Z	BDP 300 X Y Z	BDP 350 X Y Z	BDP 400 X Y Z
8'	16 36 49	18 38 52	15 33 45	21 44 60	24 49 67	22 46 63	22 45 62	26 53 72	28 56 76	24 50 68	31 63 86	35 69 94	37 73 99	30 61 84
10'	15 34 47	17 37 51	14 31 43	20 43 59	23 48 66	21 45 62	21 44 61	25 52 71	26 55 75	23 49 67	30 62 85	34 69 94	36 72 98	29 61 83
12'	14 33 45	15 35 49	12 30 41	19 42 58	21 47 65	20 44 61	19 43 59	23 51 70	25 54 74	22 48 66	29 62 84	33 68 93	34 71 97	28 60 82
14'	12 30 42	14 33 46	11 27 37	17 40 56	20 46 63	19 43 59	18 42 57	22 50 68	24 53 73	21 47 64	28 61 83	31 67 92	33 71 96	27 59 80
16'	10 27 38	12 31 43	8 22 31	16 38 53	19 44 61	17 41 56	16 40 55	21 48 66	23 52 71	19 45 62	27 59 81	30 66 90	32 69 95	26 57 79
18'	6 20 29	9 26 37	6 18 26	14 36 50	17 42 58	15 38 53	15 37 52	19 46 64	21 50 69	18 43 59	25 58 80	29 65 89	31 68 93	24 56 77
20'				12 32 45	15 39 54	13 35 49	13 33 47	18 44 61	20 48 66	16 40 56	24 56 77	28 63 87	30 67 92	23 54 75
22'				8 24 35	13 35 49	10 29 42	8 25 37	16 41 57	18 45 63	14 36 51	22 54 75	26 62 85	28 65 90	21 52 72
24'					8 26 38	8 24 36	8 24 35	13 36 51	16 42 59	10 29 42	21 52 72	25 59 82	27 63 87	20 49 69
26'											19 48 68	23 57 79	25 61 85	18 46 64
28'											16 44 62	21 54 75	23 58 81	15 41 58
30'											12 36 52	19 50 70	21 55 77	10 32 47

Mounting Height to Bottom of Heater	60° Downward Hood For Propeller Units													
	PDP ①							BDP ②						
	PDP 150 X Y Z	PDP 175 X Y Z	PDP 200 X Y Z	PDP 250 X Y Z	PDP 300 X Y Z	PDP 350 X Y Z	PDP 400 X Y Z	BDP 150 X Y Z	BDP 175 X Y Z	BDP 200 X Y Z	BDP 250 X Y Z	BDP 300 X Y Z	BDP 350 X Y Z	BDP 400 X Y Z
8'	0 38 52	0 40 55	0 35 47	0 47 65	0 52 72	0 49 68	0 48 66	0 56 77	0 60 82	0 53 73	0 68 93	0 74 102	0 78 107	0 66 90
10'	0 36 49	0 39 53	0 33 45	0 46 63	0 51 70	0 48 66	0 47 64	0 55 76	0 59 81	0 52 71	0 67 91	0 74 101	0 77 106	0 65 88
12'	0 33 46	0 36 50	0 30 41	0 44 60	0 50 68	0 46 64	0 45 62	0 54 74	0 57 79	0 50 69	0 65 90	0 72 99	0 76 104	0 63 87
14'	0 30 41	0 33 46	0 26 36	0 41 57	0 48 65	0 44 61	0 43 59	0 52 71	0 56 76	0 48 67	0 64 88	0 71 97	0 75 102	0 62 85
16'	0 25 35	0 29 41	0 19 27	0 38 53	0 45 62	0 41 57	0 40 55	0 50 68	0 54 74	0 46 63	0 62 85	0 69 95	0 73 100	0 60 82
18'	0 13 19	0 23 32	0 12 17	0 35 48	0 42 58	0 38 52	0 36 50	0 47 64	0 51 70	0 43 59	0 60 82	0 68 93	0 72 98	0 58 79
20'				0 29 40	0 38 52	0 33 46	0 31 43	0 43 60	0 48 66	0 39 54	0 58 79	0 65 90	0 70 95	0 55 76
22'				0 16 23	0 32 45	0 25 35	0 21 30	0 39 54	0 44 61	0 34 47	0 55 75	0 63 86	0 67 92	0 52 72
24'					0 19 28	0 16 24	0 16 23	0 33 45	0 39 54	0 24 34	0 51 70	0 60 82	0 64 89	0 48 66
26'											0 46 64	0 56 78	0 61 84	0 43 60
28'											0 40 56	0 52 72	0 57 79	0 36 50
30'											0 30 43	0 46 65	0 53 73	0 22 31

Mounting Height to Bottom of Heater	90° Downward Hood For Propeller Units													
	PDP ①							BDP ②						
	PDP 150 S	PDP 175 S	PDP 200 S	PDP 250 S	PDP 300 S	PDP 350 S	PDP 400 S	BDP 150 S	BDP 175 S	BDP 200 S	BDP 250 S	BDP 300 S	BDP 350 S	BDP 400 S
8'	38	42	36	54	62	58	56	72	79	70	98	113	121	94
10'	34	37	32	48	56	52	50	65	70	63	88	101	108	84
12'	31	34	29	44	51	47	46	59	64	58	80	92	99	77
14'	29	32	27	41	47	44	42	55	60	53	74	85	91	71
16'	27	29	25	38	44	41	39	51	56	50	70	80	85	67
18'	25	28	24	36	42	38	37	48	53	47	66	75	81	63
20'	24	26	23	34	40	36	35	46	50	45	62	71	76	60
22'	23	25	22	33	38	35	34	44	48	42	59	68	73	57
24'				31	36	33	32	42	45	41	57	65	70	55
26'				30	35	32	31	40	44	39	55	63	67	52
28'				29	33	31	30	39	42	38	53	60	65	50
30'					32	30	29	37	41	36	51	58	62	49
32'								36	39	35	49	56	60	47
34'								35	38	34	48	55	59	46
36'											46	53	57	45
38'											45	52	55	43
40'											44	50	54	42
42'											43	49	53	41

① Data based on units fired at full rated input with an entering air temperature of 60°-80°F. Maximum mounting heights higher versus units without outlet devices.

② Data based on unit fired at full rated input, 60°-80°F entering air temperature, and a 40°F temperature rise through unit. Maximum mounting heights higher versus units without outlet devices.

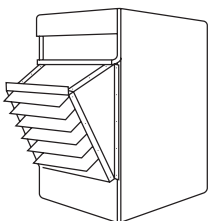

30° HOOD

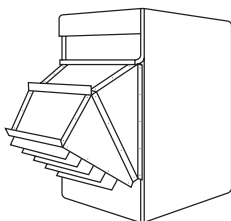

60° HOOD

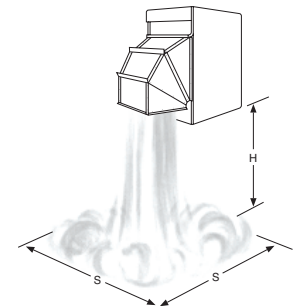
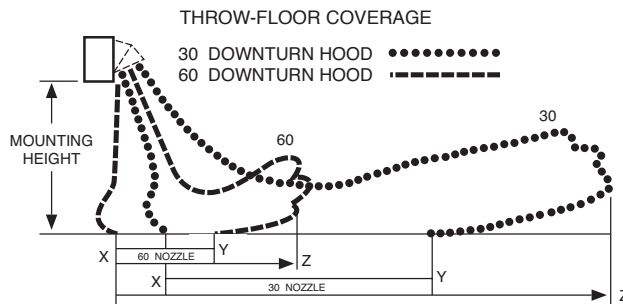

90° HOOD

# PERFORMANCE DATA – NOZZLES

Figure 23.1 - Mounting Height, Heat Throw, Heat Spread (in feet)

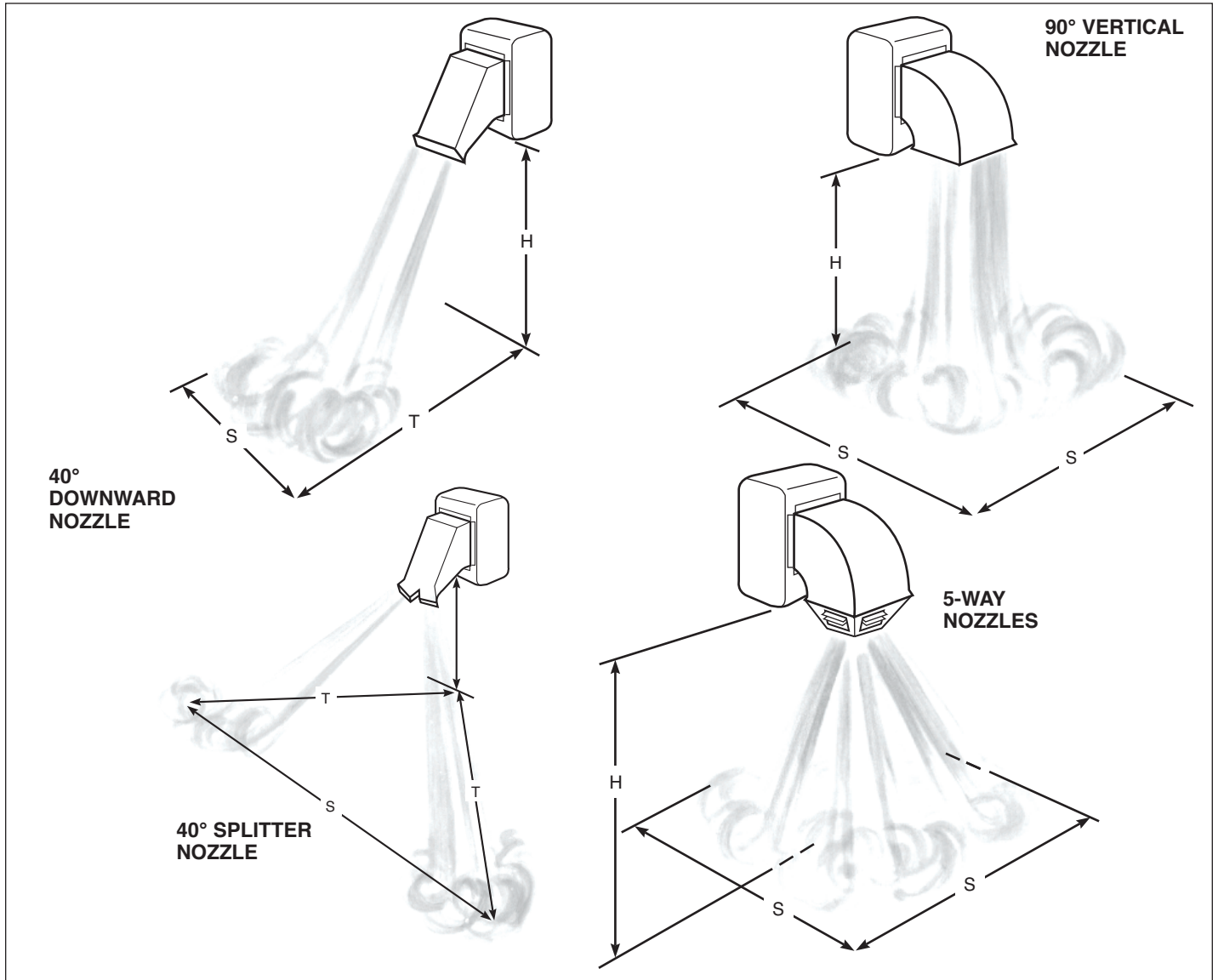

Table 23.1 - Mounting Height, Heat Throw, Heat Spread (in feet)

Nozzle Type		Model Number						
		BDP 150	BDP 175	BDP 200	BDP 250	BDP 300	BDP 350	BDP 400
40° Downward Nozzle	Max. Mounting Ht. (ft.) H	26	25	27	29	31	32	32
	Heat Throw (ft.) T	79	76	81	86	94	96	96
	Heat Spread (ft.) S	26	25	27	29	31	32	32
90° Vertical Nozzle	Max. Mounting Ht. (ft.) H	26	26	24	29	31	32	32
	Heat Spread (ft.) S	26	26	24	29	31	32	32
40° Splitter Nozzle	Max. Mounting Ht. (ft.) H	24	24	23	25	28	30	32
	Heat Throw (ft.) T	60	59	59	62	70	75	80
	Heat Spread (ft.) S	120	118	117	124	140	151	160
5-Way Nozzle	Max. Mounting Ht. (ft.) H	22	21	20	25	26	23	26
	Heat Spread (ft.) S	31	29	28	35	36	32	36

The above table is based on an inlet air temperature of 70°F and an air temperature rise of 55°F. Air deflectors on, 40° and 90° discharge nozzles set perpendicular to the face of the air discharge opening. On 5-way nozzles all air deflectors set perpendicular to floor. Static pressure measured at 0.1" W.C. for 90° nozzle, 0.2" W.C. for 40° downward and 5-way nozzle, and 0.3" W.C. for 40° splitter nozzle. Outlet velocities are approximately 1,750 FPM for the 40° nozzles, 1,000 FPM for the 90° nozzle and 1,300 FPM for 5-way. For motor size, drive and blower rpm refer to page 20. Mounting height measured from bottom of unit.

# DIMENSIONAL DATA

Figure 24.1 - Dimensional Drawings - Propeller Units (Model PDP)

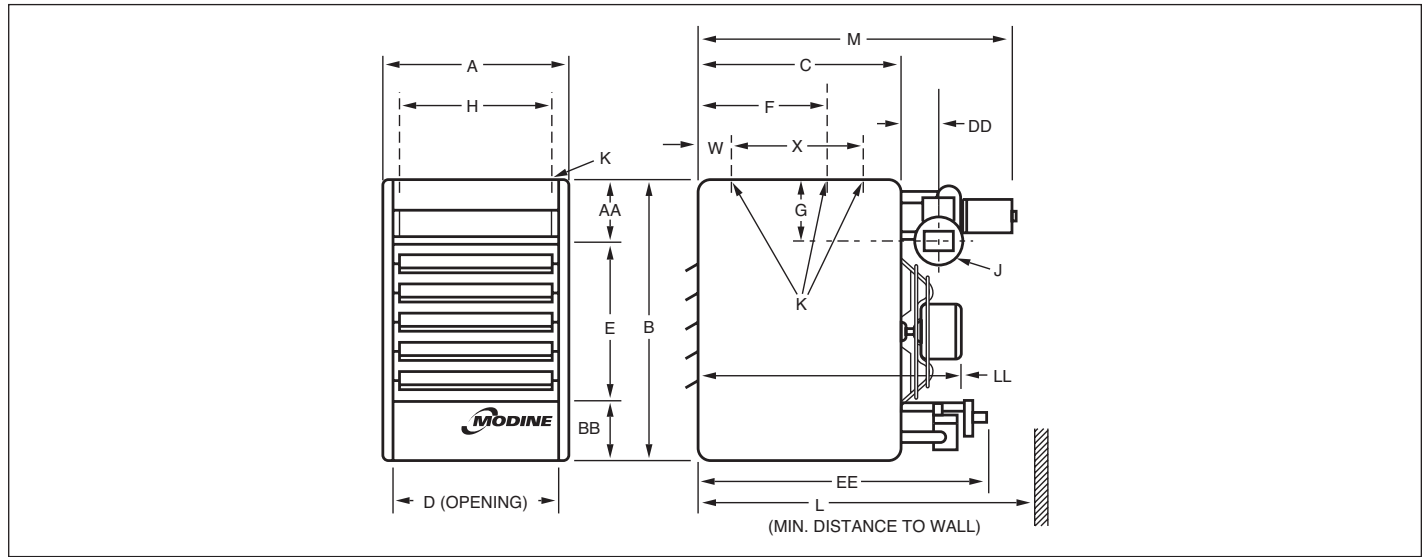

Table 24.1 - Dimensions (inches) - PDP ①

Dimension Symbol	Model Number						
	PDP 150	PDP 175	PDP 200	PDP 250	PDP 300	PDP 350	PDP 400
<b>A</b>	21	23-1/2	25-5/8	25-5/8	28-5/8	33-5/8	40
<b>B</b>	35-1/4	35-1/4	40-1/4	40-1/4	40-1/4	40-1/4	40-1/4
<b>C</b>	22	22	25	25	25	25	25
<b>D</b>	18-9/16	21-1/16	23-3/16	23-3/16	26-3/16	31-3/16	37-1/2
<b>E</b>	20	20	24	24	24	24	24
<b>F</b>	12	12	13-1/2	13-1/2	14	—	—
<b>G</b>	6-9/16	6-9/16	7-1/2	7-1/2	7-1/2	7-1/2	7-1/2
<b>H</b>	17-3/8	19-7/8	22	22	25	30	36-3/8
<b>J</b>	5 ②	5 ②	5 ②	6	6	6	6
<b>K (Mounting Holes) ③</b>	3/8-16	3/8-16	3/8-16	3/8-16	3/8-16	3/8-16	3/8-16
<b>L ④</b>	35-13/16	35-9/16	40-3/4	40-3/4	40-3/4	40-3/4	44-3/16
<b>M</b>	29-13/16	29-9/16	34-3/4	34-3/4	34-3/4	34-11/16	38-3/16
<b>W</b>	—	—	—	—	—	5	5
<b>X</b>	—	—	—	—	—	16	16
<b>AA</b>	8	8	9	9	9	9	9
<b>BB</b>	7-1/4	7-1/4	7-1/4	7-1/4	7-1/4	7-1/4	7-1/4
<b>DD</b>	2-3/4	2-3/4	3-3/8	3-3/8	3-3/8	3-3/8	6-13/16
<b>EE</b>	30-1/2	30-1/2	32-7/8	32-7/8	32-7/8	32-7/8	32-7/8
<b>LL</b>	31-1/8	31-1/8	34-7/8	34-7/8	36-1/4	35-1/2	40-1/2
<b>Gas Connections ⑤</b>	1/2	1/2	1/2	1/2	1/2	3/4	3/4
<b>Fan Diameter</b>	16	18	20	20	22	22	24
<b>Approx. Weight</b>	168	175	239	239	269	338	418

① Do not use propeller units with duct work.

② Vent connection is 5", connected to a factory supplied vent transition. For model sizes 150 and 175, the factory supplied transition is 4" (to the power exhauster outlet) to 5" (to the vent system). For model size 200, the factory supplied transition is 6" (to the power exhauster outlet) to 5" (to the vent system).

③ PDP 150 through PDP 300 - 2 holes (and the level hanging adjustment feature). PDP 350 through PDP 400 - 4 holes. (Listed is the hole diameter and threads per inch to accept threaded rod).

④ Dimension equals overall plus 6".

⑤ For natural gas; may vary depending on control availability.



# DIMENSIONAL DATA

Figure 25.1 - Dimensional Drawings - Blower Units (Model BDP)

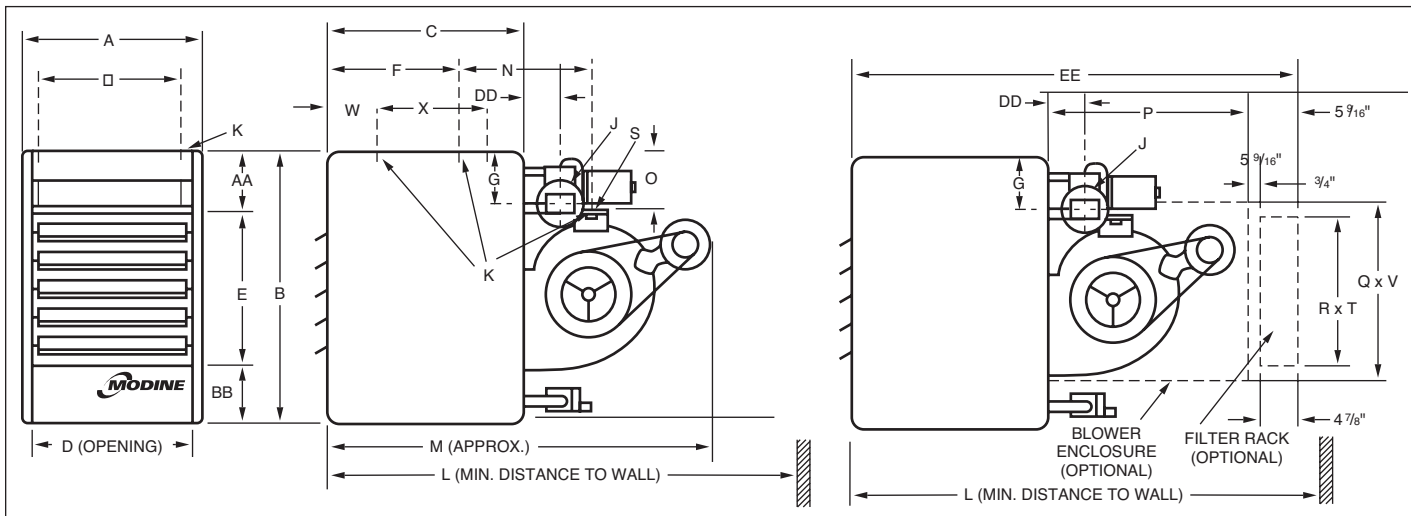

Table 25.1 - Dimensions (inches) - BDP

Dimension Symbol	Model Number						
	BDP 150	BDP 175	BDP 200	BDP 250	BDP 300	BDP 350	BDP 400
A	21	23-1/2	25-5/8	25-5/8	28-5/8	33-5/8	40
B	35-1/4	35-1/4	40-1/4	40-1/4	40-1/4	40-1/4	40-1/4
C	22	22	25	25	25	25	25
D	18-9/16	21-1/16	23-3/16	23-3/16	26-3/16	31-3/16	37-1/2
E	20	20	24	24	24	24	24
F	12	12	13-1/2	13-1/2	14	—	—
G	6-9/16	6-9/16	7-1/2	7-1/2	7-1/2	7-1/2	7-1/2
H	17-3/8	19-7/8	22	22	25	30	36-3/8
J	5 ①	5 ①	5 ①	6	6	6	6
K Mounting Holes ②	3/8-16	3/8-16	3/8-16	3/8-16	3/8-16	3/8-16	3/8-16
L w/ Blwr Encl & Filt Rk	62-5/8	62-5/8	69-5/8	69-5/8	69-5/8	69-5/8	69-5/8
L w/o Blwr Encl & Filt Rk	53-1/8	53-1/8	61	61	61	61	65
M ③	47-1/8	47-1/8	55	55	55	55	59
N ④	21-1/2	21-1/2	25-7/16	25-7/16	24-15/16	17-15/16	22
O	7-1/4	7-1/4	8-1/2	8-1/2	8-1/2	8-1/2	8-1/2
P	30	30	34	34	34	34	34
Q Blower Encl Ht	21-3/8	21-3/8	25-1/8	25-1/8	25-1/8	25-1/8	25-1/8
R Inlet Duct Height	20	20	23-3/4	23-3/4	23-3/4	23-3/4	23-3/4
S Center to Center Blower Mtg. Holes	17-5/16	17-3/8	20-3/8	20-3/8	20-3/8	20-3/8	20-3/8
T Inlet Duct Width	27-1/2	27-1/2	32-3/4	32-3/4	32-3/4	42-7/8	42-7/8
V Blower Encl Width	29	29	34-1/4	34-1/4	34-1/4	44-3/8	44-3/8
W	—	—	—	—	—	5	5
X	—	—	—	—	—	16	16
AA	8	8	9	9	9	9	9
BB	7-1/4	7-1/4	7-1/4	7-1/4	7-1/4	7-1/4	7-1/4
DD	2-3/4	2-3/4	2-3/4	3-3/8	3-3/8	3-3/8	6-13/16
EE	56-5/8	56-5/8	63-5/8	63-5/8	63-5/8	63-5/8	63-5/8
Gas Connections ⑤	1/2	1/2	1/2	1/2	1/2	3/4	3/4
Blower Wheel Diameter	13	13	15	15	15	15	15
Approx. Weight	152	152	315	315	339	428	498

① Vent connection is 5", connected to a factory supplied vent transition. For model sizes 150 and 175, the factory supplied transition is 4" (to the power exhauster outlet) to 5" (to the vent system). For model size 200, the factory supplied transition is 6" (to the power exhauster outlet) to 5" (to the vent system).

② BDP 150 thru BDP 300 — 4 holes (2 on blower and 2 on unit). BDP 350 and BDP 400 — 6 holes (2 on blower and 4 on unit). (Listed is the hole diameter and threads per inch to accept threaded rod).

③ This is an approximate dimension for standard motors, allow 3" for sheave and optional motors.

④ Distance between mounting hole in unit casing and mounting hole on blower. On the BDP 350 and BDP 400, the distance is from rear mounting hole in casing to the mounting hole on blower.

⑤ For natural gas; may vary depending on control availability.

# MAINTENANCE

## **WARNING**

When servicing or repairing this equipment, use only factory-approved service replacement parts. A complete replacement parts list may be obtained by contacting the factory. Refer to the rating plate on the appliance for complete appliance model number, serial number, and company address. Any substitution of parts or controls not approved by the factory will be at the owner's risk.

## **CAUTION**

1. Service or repair of this equipment must be performed by a qualified service agency.
2. Do not attempt to reuse any mechanical or electrical controllers which have been wet. Replace defective controller.

**NOTE:** To check most of the possible remedies in the troubleshooting guide listed in Table 27.1, refer to the applicable sections of the manual.

### General Maintenance

The unit and venting system must be checked once a year by a qualified service technician.

**All installation and service of these units must be performed by a qualified installation and service agency.**

**Before any service, BE SURE TO TURN OFF GAS AT THE MANUAL SHUT-OFF VALVE AHEAD OF THE COMBINATION GAS CONTROL AND TURN OFF ALL ELECTRIC POWER TO THE HEATER.**

### General Unit

When providing annual maintenance for the unit heater, keep the unit free from dust, dirt, grease and foreign matter. Pay particular attention to:

1. The combustion air and exhaust vent piping.
2. The burner ports and pilot burner orifices (avoid the use of hard, sharp instruments capable of damaging surfaces for cleaning these ports). To check the burner port and pilot burner orifice, see "Burner and Pilot Assembly Removal".
3. The air shutters and main burner orifices (avoid the use of hard, sharp instruments capable of damaging surfaces for cleaning these orifices). To check the air shutters and main burner orifices, see for "Manifold Assembly Removal."
4. The heat exchanger. Clean tubes from the bottom with a stiff non-wire brush.
5. The heat exchanger should be checked annually for cracks and discoloration of the tubes. If a crack is detected, the heat exchanger should be replaced before the unit is put back into service. If the tubes are dark gray, airflow across the heat exchanger should be checked to insure that a blockage has not occurred or the blower is operating properly.

### Electrical Wiring

The electrical wiring should be checked annually for loose connections or deteriorated insulation.

### Gas Piping & Controls

The gas valves and piping should be checked annually for general cleanliness and tightness.

The gas controls should be checked to ensure that the unit is operating properly.

### Propeller Assembly

Check the motor for lubrication if the motor is not permanently lubricated. Inspect the fan for damage and fit on motor shaft. Clean any dust, dirt or foreign matter from the fan blades.

### Blower Assembly

The blower assembly includes the bearings, drive sheaves and belts. Blower bearings should be checked and lubricated based on the blower manufacturer's recommendations. Bearings should also be checked for any unusual wear and replaced if needed.

Drive sheaves should be checked at the same time the bearings are inspected. Check to make sure the sheaves are in alignment and are securely fastened to the blower and motor shafts.

Belt tension should be rechecked shortly after the unit has been installed to check for belt stretching. After the initial start-up, monthly checks are recommended.

### Manifold Assembly Removal

To remove the manifold:

1. Shut off gas and electric supply.
2. Lower bottom pan to expose burner and manifold (see Figure 16.2).
3. Disconnect pilot tubing and thermocouple lead (or ignition cable) at the combination gas control (and ignition control).
4. Disconnect control wires for the combination gas control.
5. Disconnect gas manifold at ground union joint.
6. Remove the 2 screws holding the manifold to the heat exchanger support.
7. Clean the orifices and adjust the air shutters as necessary.
8. Follow steps 2-6 in reverse order to install the manifold assembly.
9. Turn on the electric and gas supply.
10. Check the ground union joint for leaks with a soap solution. Tighten if necessary.

### Burner and Pilot Assembly Removal

To remove the burner:

1. Shut off gas and electric supply.
2. Lower bottom pan to expose burner and manifold (see Figure 16.2).
3. Disconnect pilot tubing and thermocouple lead (or ignition cable) at the combination gas control (and ignition control).
4. Remove the 2 burner retaining pins holding the burner in place. The burner can then be easily lowered from the unit.
5. Examine the burner and pilot assembly for cleanliness and/or obstructions as necessary (see "General Unit" for cleaning instructions).
6. Replace the burner assembly in reverse order. In replacing the burner, be certain that the slots at the front of the burner are located properly on their shoulder rivets and that the burner retaining pins are put back into their proper locations.
7. Reconnect the ignition cable and pilot gas supply line.
8. Turn on the electric and gas supply.

# SERVICE & TROUBLESHOOTING

Table 27.1 - Troubleshooting

Trouble	Possible Cause	Possible Remedy
<b>Pilot does not light</b>	<ol style="list-style-type: none"> <li>1. Main gas is off.</li> <li>2. Power supply is off.</li> <li>3. Air in gas line.</li> <li>4. Dirt in pilot orifice.</li>   <li>5. Gas pressure out of proper range.</li>   <li>6. Pilot valve does not open.               <ol style="list-style-type: none"> <li>a. Defective ignition controller.</li> <li>b. Blown fuse on control board</li> <li>c. Defective gas valve.</li> </ol> </li> <li>7. No spark at ignitor.               <ol style="list-style-type: none"> <li>a. Loose wire connections.</li> <li>b. Pilot sensor is grounded.</li> <li>c. Blown fuse on control board</li> <li>d. Defective ignition controller.</li> </ol> </li> <li>8. Safety device has cut power.</li>   <li>9. Pilot valve is off.</li>   <li>10. Dirty thermocouple contact.</li>   <li>11. Excessive drafts.</li>   <li>12. Pilot orifice Fitting leak.</li> </ol>	<ol style="list-style-type: none"> <li>1. Open manual gas valve.</li> <li>2. Turn on main power.</li> <li>3. Purge gas line.</li> <li>4. Check for plugged pilot orifice and clean with compressed air if necessary.</li> <li>5. Adjust to a maximum of 14" W.C. Minimum for natural gas - 6" W.C. Minimum for propane gas - 11" W.C.</li> <li>6. Check wiring for 24 volts to valve.               <ol style="list-style-type: none"> <li>a. Replace ignition controller.</li> <li>b. Replace Fuse</li> <li>c. Replace gas valve.</li> </ol> </li> <li>7.               <ol style="list-style-type: none"> <li>a. Check all ignition controller wiring.</li> <li>b. Replace sensor if cracked or worn</li> <li>c. Replace fuse</li> <li>d. Replace ignition controller.</li> </ol> </li> <li>8. Check all safety devices (High limit, pressure switch, blocked vent safety switch, etc.) Determine and correct problem. Reset if necessary.</li> <li>9. Turn gas control knob or lever on combination gas control to pilot position.</li> <li>10. Be sure thermocouple contact is clean. If problem persists replace thermocouple.</li> <li>11. Find source and re-direct airflow away from unit.</li> <li>12. Tighten pilot orifice. Flame impingement on thermocouple may cause thermocouple to become inoperative.</li> </ol>
<b>Main burners do not light (Pilot is lit)</b>	<ol style="list-style-type: none"> <li>1. Defective valve.</li> <li>2. Loose wiring.</li> <li>3. Defective pilot sensor</li> <li>4. Defective ignition controller.</li> <li>5. Improper thermostat wiring.</li> </ol>	<ol style="list-style-type: none"> <li>1. Replace valve.</li> <li>2. Check wiring to gas valve.</li> <li>3. Replace pilot sensor.</li> <li>4. Replace ignition controller.</li> <li>5. Verify wiring compared to wiring diagram.</li> </ol>
<b>Lifting Flames (See Figure 28.2)</b>	<ol style="list-style-type: none"> <li>1. Too much primary air.</li> <li>2. Main pressure set too high.</li> <li>3. Orifice too large.</li> </ol>	<ol style="list-style-type: none"> <li>1. Reduce primary air.</li> <li>2. Adjust to a maximum of 14" W.C.</li> <li>3. Check orifice size with those listed on the serial plate.</li> </ol>
<b>Yellow Tipping</b> (With propane gas, some yellow tipping is always present.)	<ol style="list-style-type: none"> <li>1. Insufficient primary air.</li> <li>2. Dirty orifice.</li> <li>3. Misaligned orifice.</li> </ol>	<ol style="list-style-type: none"> <li>1. Increase primary air.</li> <li>2. Check orifices and clean with compressed air if necessary.</li> <li>3. Check manifold, replace if necessary.</li> </ol>
<b>Wavering Flames (See Figure 28.1)</b>	<ol style="list-style-type: none"> <li>1. Drafts across burner</li> <li>2. Misalignment of burner</li> <li>3. Cracked heat exchanger</li> </ol>	<ol style="list-style-type: none"> <li>1. Eliminate drafts</li> <li>2. Align burner on locator pins</li> <li>3. Replace heat exchanger</li> </ol>
<b>Flashback</b>	<ol style="list-style-type: none"> <li>1. Too much primary air</li> <li>2. Main pressure set too high.</li> <li>3. Orifice too large.</li> </ol>	<ol style="list-style-type: none"> <li>1. Reduce primary air.</li> <li>2. Adjust to maximum of 14" W.C.</li> <li>3. Check orifice size with those listed on the serial plate.</li> </ol>
<b>Floating Flames (see Figure 28.3)</b>	<ol style="list-style-type: none"> <li>1. Insufficient primary air.</li> <li>2. Main pressure set too high.</li> <li>3. Orifice too large.</li> <li>4. Blocked vent.</li> </ol>	<ol style="list-style-type: none"> <li>1. Increase primary air.</li> <li>2. Adjust to a maximum of 14" W.C.</li> <li>3. Check orifice size with those listed on the serial plate.</li> <li>4. Clean/correct venting system.</li> </ol>
<b>Flame Rollout (see Figure 28.4)</b>	<ol style="list-style-type: none"> <li>1. Main pressure set too high.</li> <li>2. Orifice too large.</li> <li>3. Blocked vent.</li> </ol>	<ol style="list-style-type: none"> <li>1. Adjust to a maximum of 14" W.C.</li> <li>2. Check orifice size with those listed on the serial plate.</li> <li>3. Clean/correct venting system.</li> </ol>

# SERVICE & TROUBLESHOOTING

Trouble	Possible Cause	Possible Remedy
<b>Not Enough Heat</b>	<ol style="list-style-type: none"> <li>Unit cycling on high limit. ①               <ol style="list-style-type: none"> <li>Obstructions/leaks in duct system.</li> <li>Main pressure set too high.</li> <li>Blower motor not energized.</li> </ol> </li> <li>Loose belt</li> <li>Blower speed too low.</li> <li>Blocked/damaged venting system.</li> <li>Air distribution baffle removed (high temperature rise units only).</li> <li>Defective high limit switch.</li> </ol> <ol style="list-style-type: none"> <li>Main pressure set too low.</li> </ol> <ol style="list-style-type: none"> <li>Too much outside air.</li> </ol> <ol style="list-style-type: none"> <li>Thermostat malfunction.</li> <li>Gas controls wired incorrectly.</li> </ol> <ol style="list-style-type: none"> <li>Unit undersized.</li> </ol>	<ol style="list-style-type: none"> <li> <ol style="list-style-type: none"> <li>Clean/correct duct system.</li> <li>Adjust to a maximum of 14" W.C.</li> <li>Check/correct to insure blower motor operates within 45 seconds of when gas controls are energized.</li> <li>Adjust belt tension.</li> <li>Check/correct blower drive settings for proper rpm.</li> <li>Check/correct venting system.</li> <li>Replace air distribution baffle.</li> <li>Replace high limit switch.</li> </ol> </li> <li>Adjust main gas pressure. Minimum for natural gas — 6" W.C. Minimum for propane gas — 11" W.C.</li> <li>Adjust outside air damper to decrease outside air percentage (if possible).</li> <li>Check/replace thermostat.</li> <li>Check unit wiring against the wiring diagram.</li> <li>Check design conditions. If unit is undersized, an additional unit(s) or other heat source must be added.</li> </ol>
<b>Too Much Heat</b>	<ol style="list-style-type: none"> <li>Thermostat malfunction.</li> <li>Gas controls do not shut-off.               <ol style="list-style-type: none"> <li>Gas controls wired incorrectly.</li> <li>Short circuit.</li> </ol> </li> <li>Main gas pressure set too high.</li> <li>Defective gas valve.</li> </ol>	<ol style="list-style-type: none"> <li>Check/replace thermostat.</li> <li> <ol style="list-style-type: none"> <li>Check unit wiring against the wiring diagram.</li> <li>Check for loose or worn wires.</li> </ol> </li> <li>Adjust to a maximum of 14" W.C.</li> <li>Replace gas valve.</li> </ol>

## ① Automatic Reset High Limit

The unit heater comes standard with an automatic reset high limit switch that will shut off the gas should the discharge air temperature become excessive. See Figure 18.1, indicator ⑦ for the location of either the standard automatic high limit switch. The switch should operate only when something is seriously wrong with the unit operation. Anytime the switch operates, correct the difficulty immediately or serious damage may result. If the switch cuts off the gas supply during normal operation, refer to the "Not Enough Heat" section of Service & Troubleshooting.

**Figure 28.1 - Wavering Flame or Misalignment**

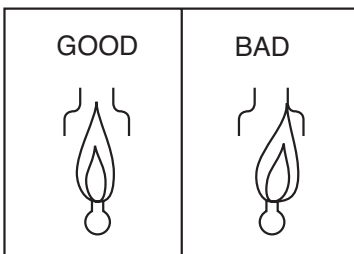

**Figure 28.2 - Lifting Flame Condition**

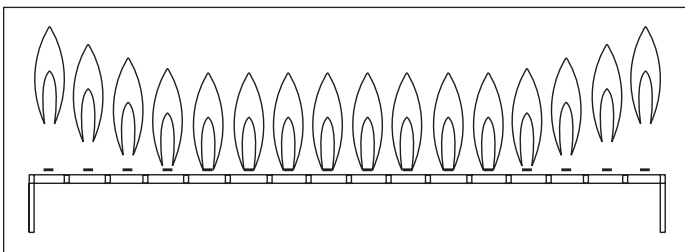

**Figure 28.3 - Floating Flame Condition**

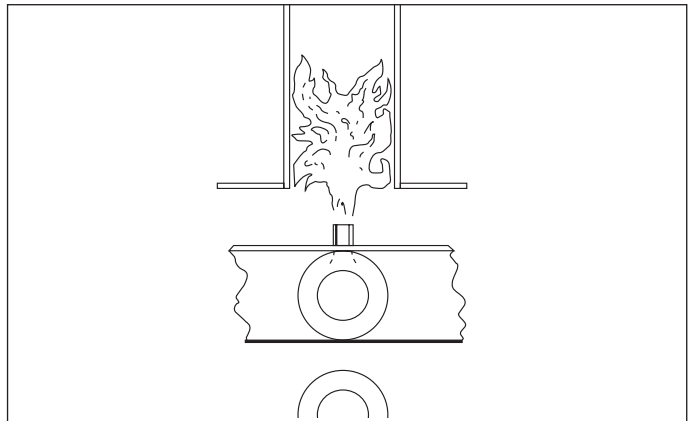

**Figure 28.4 - Flame Rollout Appearance**

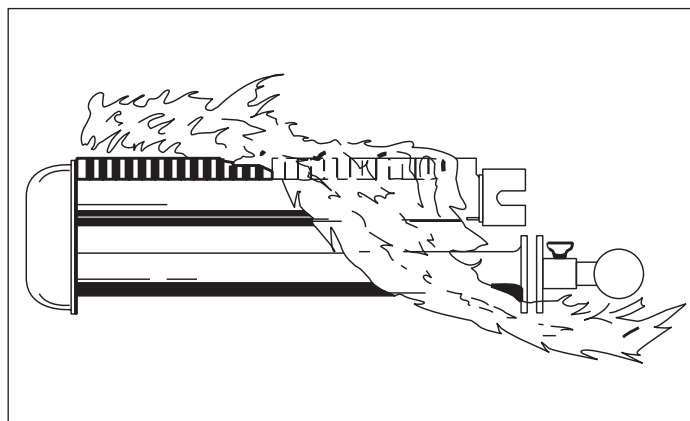

# MODEL NUMBER / RATING PLATE IDENTIFICATION

Figure 29.1 - Serial Number Designations

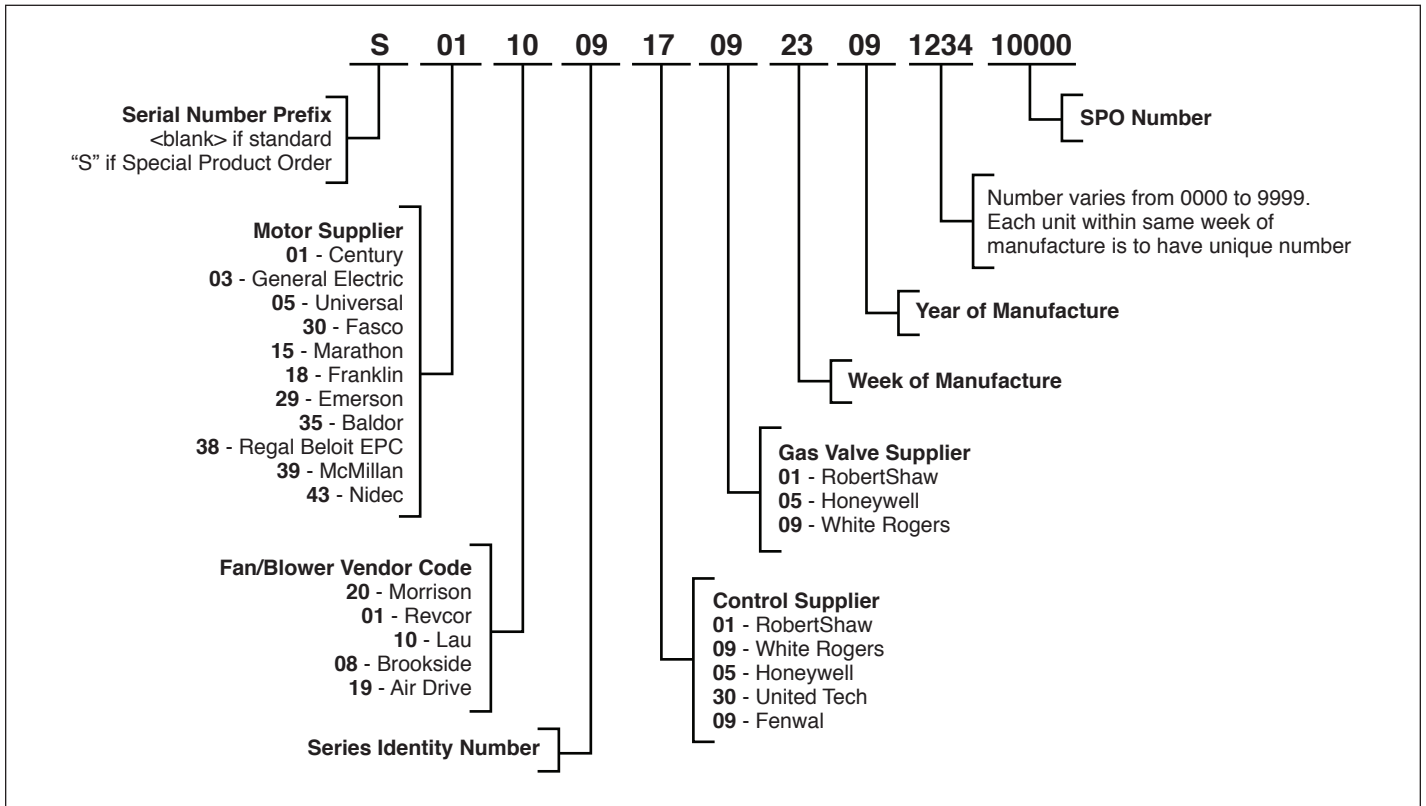
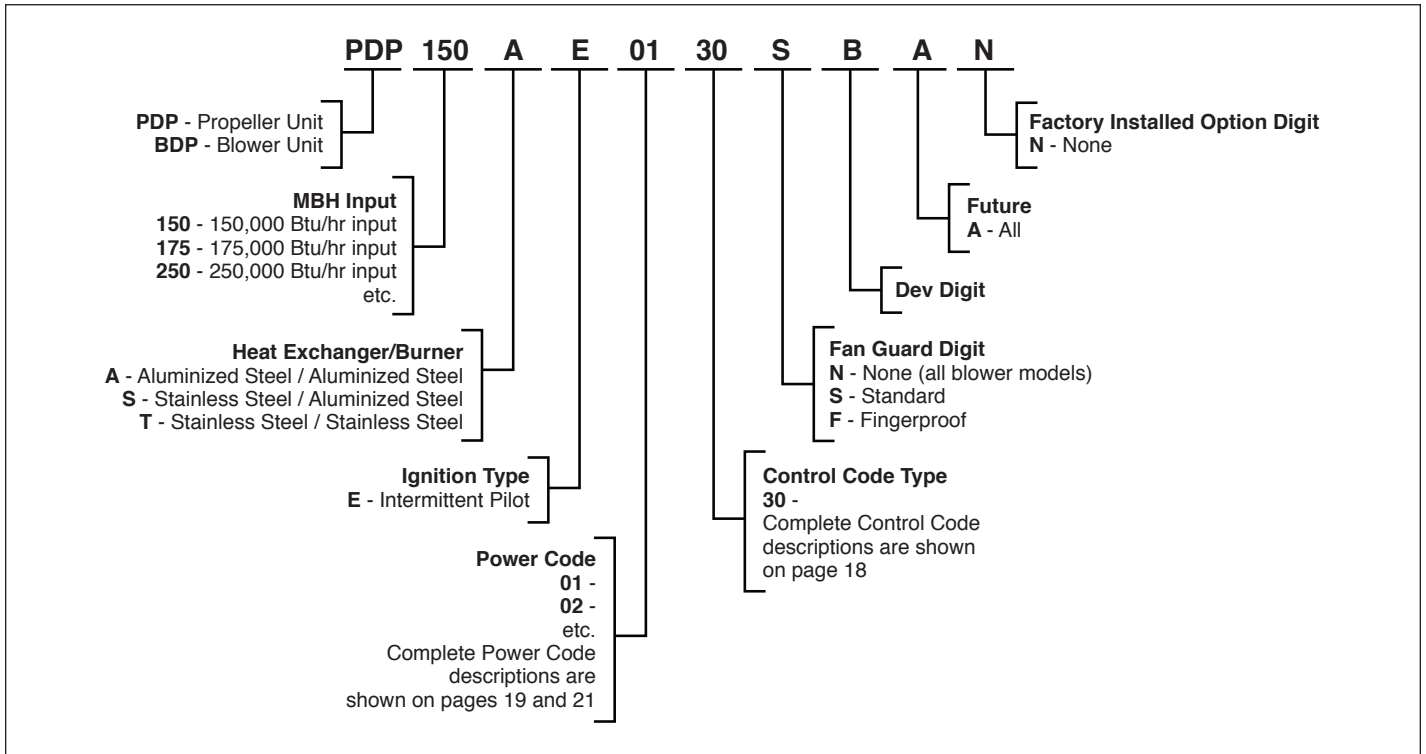

Figure 29.2 - Model Number Designations



**THIS PAGE INTENTIONALLY LEFT BLANK**

**THIS PAGE INTENTIONALLY LEFT BLANK**

# COMMERCIAL WARRANTY

Seller warrants its products to be free from defects in material and workmanship, EXCLUSIVE, HOWEVER, of failures attributable to the use of materials substituted under emergency conditions for materials normally employed. This warranty covers replacement of any parts furnished from the factory of Seller, but does not cover labor of any kind and materials not furnished by Seller, or any charges for any such labor or materials, whether such labor, materials or charges thereon are due to replacement of parts, adjustments, repairs, or any other work done. This warranty does not apply to any equipment which shall have been repaired or altered outside the factory of Seller in any way so as, in the judgment of Seller, to affect its stability, nor which has been subjected to misuse, negligence, or operating conditions in excess of those for which such equipment was designed. This warranty does not cover the effects of physical or chemical properties of water or steam or other liquids or gases used in the equipment.

**BUYER AGREES THAT SELLER'S WARRANTY OF ITS PRODUCTS TO BE FREE FROM DEFECT IN MATERIAL AND WORKMANSHIP, AS LIMITED HEREIN, SHALL BE IN LIEU OF AND EXCLUSIVE OF ALL OTHER WARRANTIES, EITHER EXPRESS OR IMPLIED, WHETHER ARISING FROM LAW, COURSE OF DEALING, USAGE OF TRADE, OR OTHERWISE, THERE ARE NO OTHER WARRANTIES, INCLUDING WARRANTY OF MERCHANTABILITY OR FITNESS FOR PURPOSE, WHICH EXTEND BEYOND THE PRODUCT DESCRIPTION CONFIRMED BY BUYER AND SELLER AS OF THE DATE OF FINAL AGREEMENT.**

This warranty is void if the input to the product exceeds the rated input as indicated on the product serial plate by more than 5% on gas-fired and oil-fired units, or if the product in the judgment of SELLER has been installed in a corrosive atmosphere, or subjected to corrosive fluids or gases, been subjected to misuse, negligence, accident, excessive thermal shock, excessive humidity, physical damage, impact, abrasion, unauthorized alterations, or operation contrary to SELLER'S printed instructions, or if the serial number has been altered, defaced or removed.

**BUYER AGREES THAT IN NO EVENT WILL SELLER BE LIABLE FOR COSTS OF PROCESSING, LOST PROFITS, INJURY TO GOODWILL, OR ANY OTHER CONSEQUENTIAL OR INCIDENTAL DAMAGES OF ANY KIND RESULTING FROM THE ORDER OR USE OF ITS PRODUCT, WHETHER ARISING FROM BREACH OF WARRANTY, NONCONFORMITY TO ORDERED SPECIFICATIONS, DELAY IN DELIVERY, OR ANY LOSS SUSTAINED BY THE BUYER.**

BUYER'S REMEDY FOR BREACH OF WARRANTY, EXCLUSIVE OF ALL OTHER REMEDIES PROVIDED BY LAW, IS LIMITED TO REPAIR OR REPLACEMENT AT THE FACTORY OF SELLER, ANY COMPONENT WHICH SHALL, WITHIN THE APPLICABLE WARRANTY PERIOD DEFINED HEREIN AND UPON PRIOR WRITTEN APPROVAL, BE RETURNED TO SELLER WITH TRANSPORTATION CHARGES PREPAID AND WHICH THE EXAMINATION OF SELLER SHALL DISCLOSE TO HAVE BEEN DEFECTIVE; EXCEPT THAT WHEN THE PRODUCT IS TO BE USED BY BUYER AS A COMPONENT PART OF EQUIPMENT MANUFACTURED BY BUYER, BUYER'S REMEDY FOR BREACH, AS LIMITED HEREIN, SHALL BE LIMITED TO ONE YEAR FROM DATE OF SHIPMENT FROM SELLER. FOR GAS-FIRED PRODUCTS INSTALLED IN HIGH HUMIDITY APPLICATIONS AND UTILIZING STAINLESS STEEL HEAT EXCHANGERS, BUYER'S REMEDY FOR BREACH, AS LIMITED HEREIN, SHALL BE LIMITED TO TEN YEARS FROM DATE OF SHIPMENT FROM SELLER.

These warranties are issued only to the original owner-user and cannot be transferred or assigned. No provision is made in these warranties for any labor allowance or field labor participation. Seller will not honor any expenses incurred in its behalf with regard to repairs to any of Seller's products. No credit shall be issued for any defective part returned without proper written authorization (including, but not limited to, model number, serial number, date of failure, etc.) and freight prepaid.

## OPTIONAL SUPPLEMENTAL WARRANTY

Provided a supplemental warranty has been purchased, Seller extends the warranty herein for an additional four (4) years on certain compressors. Provided a supplemental warranty has been purchased, Seller extends the warranty herein for an additional four (4) years or nine (9) years on certain heat exchangers.

## EXCLUSION OF CONSUMABLES & CONDITIONS BEYOND SELLER'S CONTROL

This warranty shall not be applicable to any of the following items: refrigerant gas, belts, filters, fuses and other items consumed or worn out by normal wear and tear or conditions beyond Seller's control, including (without limitation as to generality) polluted or contaminated or foreign matter contained in the air or water utilized for heat exchanger (condenser) cooling or if the failure of the part is caused by improper air or water supply, or improper or incorrect sizing of power supply.

<b>Component</b> Applicable Models	<b>"APPLICABLE WARRANTY PERIOD"</b>
<b>Heat Exchangers</b> Gas-Fired Units	TEN YEARS FROM DATE OF FIRST BENEFICIAL USE BY BUYER OR ANY OTHER USER, WITHIN TEN YEARS FROM DATE OF RESALE BY BUYER OR ANY OTHER USER, WITHIN TEN YEARS FROM DATE OF RESALE BY BUYER IN ANY UNCHANGED CONDITION, OR WITHIN ONE HUNDRED TWENTY-SIX MONTHS FROM DATE OF SHIPMENT FROM SELLER, WHICHEVER OCCURS FIRST
<b>Heat Exchangers</b> Low Intensity Infrared Units  <b>Compressors</b> Condensing Units for Cassettes	FIVE YEARS FROM DATE OF FIRST BENEFICIAL USE BY BUYER OR ANY OTHER USER, WITHIN FIVE YEARS FROM DATE OF RESALE BY BUYER OR ANY OTHER USER, WITHIN FIVE YEARS FROM DATE OF RESALE BY BUYER IN ANY UNCHANGED CONDITION, OR WITHIN SIXTY-SIX MONTHS FROM DATE OF SHIPMENT FROM SELLER, WHICHEVER OCCURS FIRST
<b>Burners</b> Low Intensity Infrared Units  <b>Other</b> Components excluding Heat Exchangers, Coils, Condensers, Burners, Sheet Metal	TWO YEARS FROM DATE OF FIRST BENEFICIAL USE BY BUYER OR ANY OTHER USER, WITHIN TWO YEARS FROM DATE OF RESALE BY BUYER IN ANY UNCHANGED CONDITION, OR WITHIN THIRTY MONTHS FROM DATE OF SHIPMENT FROM SELLER, WHICHEVER OCCURS FIRST
<b>Heat Exchangers/Coils</b> Indoor and Outdoor Duct Furnaces and System Units, Steam/Hot Water Units, Oil-Fired Units, Electric Units, Cassettes, Vertical Unit Ventilators, Geothermal Units  <b>Compressors</b> Vertical Unit Ventilators, Geothermal Units  <b>Burners</b> High Intensity Infrared Units  <b>Sheet Metal Parts</b> All Products	ONE YEAR FROM DATE OF FIRST BENEFICIAL USE BY BUYER OR ANY OTHER USER, WITHIN ONE YEAR FROM DATE OF RESALE BY BUYER IN ANY UNCHANGED CONDITION, OR WITHIN EIGHTEEN MONTHS FROM DATE OF SHIPMENT FROM SELLER, WHICHEVER OCCURS FIRST

As Modine Manufacturing Company has a continuous product improvement program, it reserves the right to change design and specifications without notice.



**Commercial Products Group**  
 Modine Manufacturing Company  
 1500 DeKoven Avenue  
 Racine, WI 53403  
 Phone: 1.800.828.4328 (HEAT)  
 www.modinehvac.com